

J. H. PATTEE.

Improvement in Steam Vacuum-Pumps.

No. 129,051.

Patented July 16, 1872.

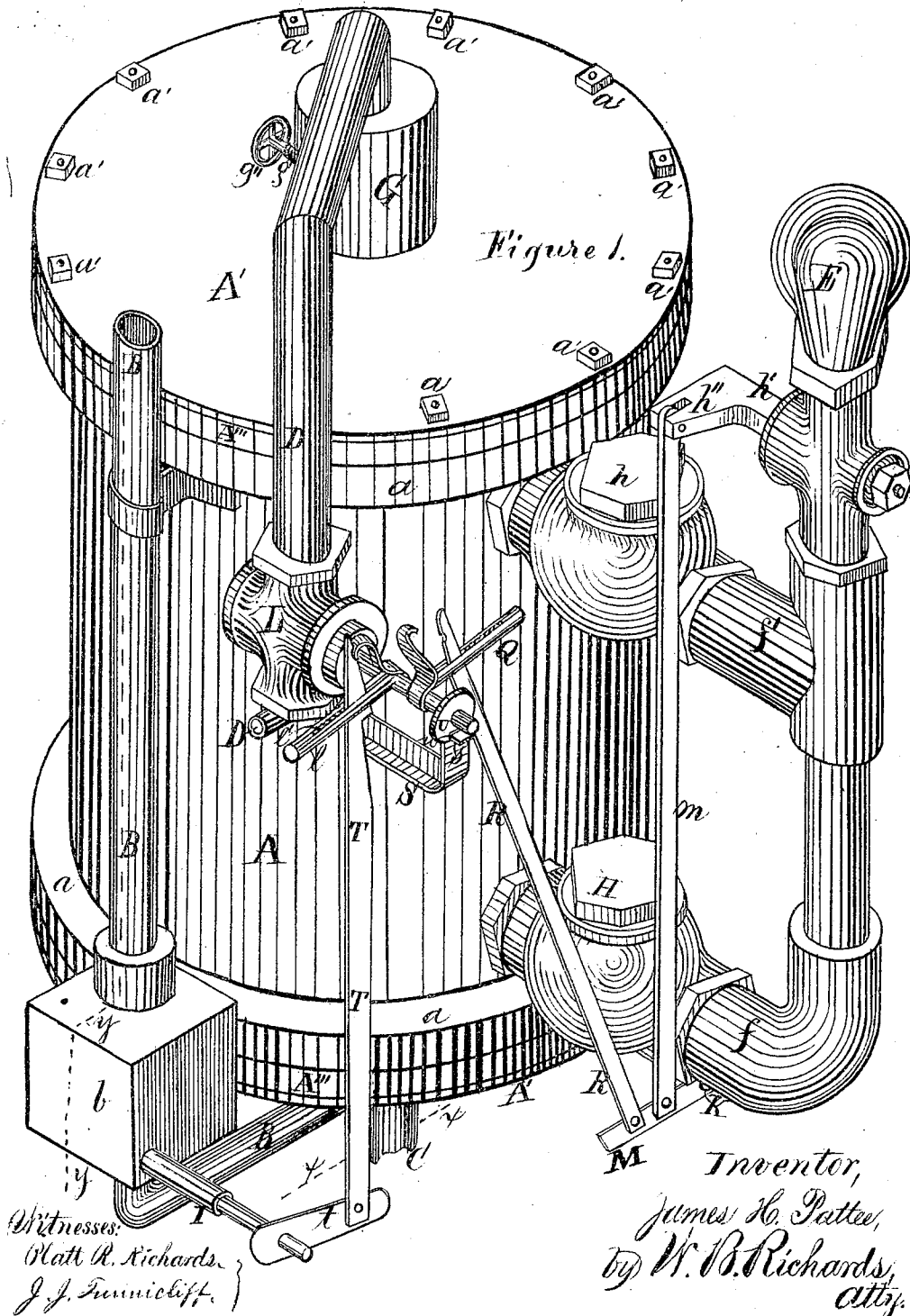

Witnesses:
Wm. A. Richards,
J. J. Funnelliff.

Inventor,
James H. Pattee,
by W. B. Richards,
Atty.

J. H. PATTEE.

Improvement in Steam Vacuum-Pumps.

No. 129,051.

Patented July 16, 1872.

Fig. 2.

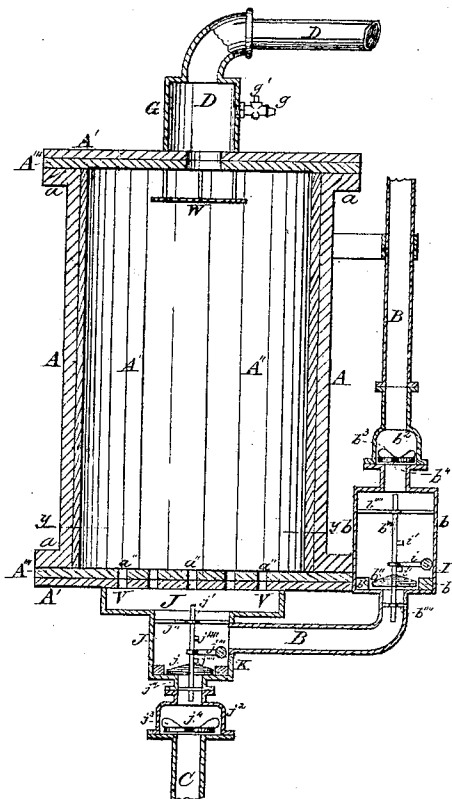

Fig. 3.

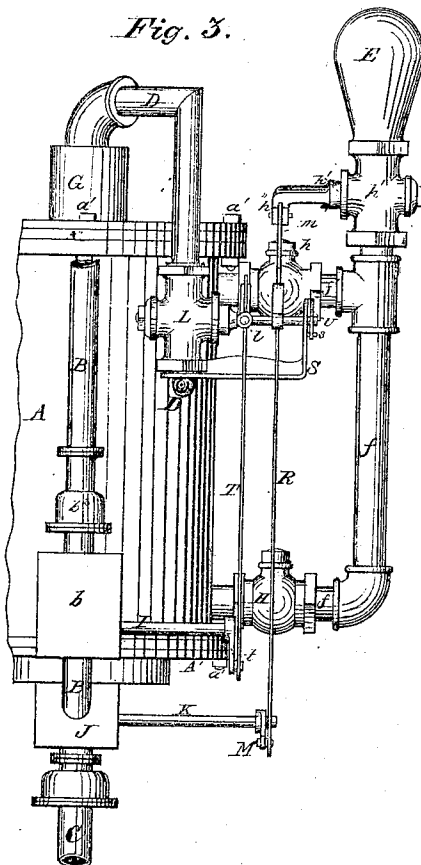

Fig. 4.

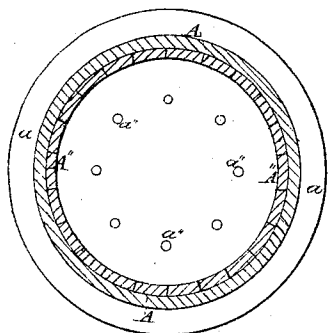

Fig. 5.

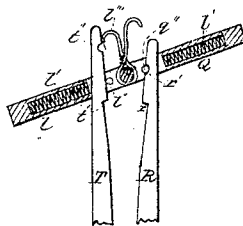

Fig. 6.



Witnesses:

M. Gardner
A. C. Townsend

Inventor:

James H. Pattee
 by *A. McCallum*
 Atty

UNITED STATES PATENT OFFICE.

JAMES H. PATTEE, OF MONMOUTH, ILLINOIS.

IMPROVEMENT IN STEAM VACUUM-PUMPS.

Specification forming part of Letters Patent No. 129,051, dated July 16, 1872.

SPECIFICATION.

I, JAMES H. PATTEE, of Monmouth, in the county of Warren and State of Illinois, have invented certain Improvements in Steam Vacuum-Pumps, of which the following is a specification:

Nature and Objects of the Invention.

The nature of my invention relates to improvements in that class of pumps known as steam vacuum-pumps; and the invention consists in an arrangement of valve-gear so combined with and operated by the valves in the water inlet and outlet pipes as to operate and control the valves for the admission of steam, and for the admission of water for condensation purposes, all as arranged and hereafter fully described, for the purpose of rendering the whole device automatic. It further consists in so constructing the entrance to the water-outlet pipe as to prevent the rotary motion of the water common to the ordinary outlet, all as hereinafter fully described. It further consists in the arrangement of a supplementary water-outlet pipe to relieve the concussion common to single valves, all as hereinafter fully described. It further consists in improvements of the details of the valve-gear, all as hereinafter fully described. It further consists in the arrangement of a supplementary valve in the water-inlet pipe, all as hereinafter fully described.

Description of the Accompanying Drawing.

Figure 1 is a perspective view of a machine embodying my invention. Fig. 2 is a sectional view of same, showing the valve-chambers, &c. Fig. 3 is a side elevation of the same. Fig. 4 is a cross-section on the line *yy* of Fig. 2. Fig. 5 is a detached view of part of the valve-gear, partly in section and partly in elevation; Fig. 6, elevation of disk U, Fig. 1.

General Description.

A is an iron cylinder, with annular flanges *a a* on each end, and heads A' A' bolted thereto by bolts *a' a' a' a'*. The cylinder A is lined with wooden staves A'' A'', and the heads A' A' are lined with wooden disks A''' A'''. B is the water-outlet pipe; C, the water-inlet pipe; D, the steam-inlet pipe. E is an air-dome, connected with the lower part of the cylinder A by a pipe, *f*, and with the upper part by

a pipe, *f'*. G is an air-chamber on the steam-inlet pipe D where it enters the cylinder A. *g* is a small pipe, extending outward from the air-chamber G. *g'* is a valve in the pipe *g*, opening toward the air-chamber G. *g''* is a pet-cock in the pipe *g*. H is a check-valve in the pipe *f*, opening from the cylinder A outward. *h* is a check-valve in the pipe *f'*, opening toward the cylinder A. *h'* is a two-way cock in the pipe *f'*, above the pipe *f'*. *h''* is a crank on the outward end of the key to the cock *h'*. *b* is a valve-chamber on the water-outlet pipe B, its upper part enlarged, and its lower part contracted to the size of the valve *b''*, as shown at *b'*. The valve *b''* is seated on the upper end of the pipe B, where it enters the chamber *b*. *b'''* is a vertical rod, carrying the valve *b''*. *b'''' b''''* are rods or guides, having eyes or holes, through which the rod *b'''* reciprocates longitudinally. I is a shaft, extending through the chamber *b* and outward, as shown at Figs. 1 and 3. *i* is a tappet-crank on the shaft I, inside of the chamber *b*, and has a forked end astride the rod *b'''*. *i' i'* are tappet-nuts on the rod *b'''*, one above and one below the forked end of the crank *i*. *b²* is a valve-chamber a short distance above the chamber *b* on the outlet-pipe B. *B³* is a check-valve of the wing kind, and is pierced centrally with a hole, *b⁴*. J is a valve-chamber on the water-inlet pipe C, its lower part contracted to the size of the valve *j*, as shown at Fig. 2. *j* is a valve in the chamber J, and is seated on the upper end of the supplementary valve-chamber *j²*. *j'* is a vertical rod, carrying the valve *j*; and *j''* are guide-rods, with eyes, through which the rod *j* reciprocates longitudinally. The valve-chamber *j²* is provided with a valve, *j³*, pierced with a central hole, *j⁴*. K is a shaft extending through the valve-chamber J and outwardly, as shown at Figs. 1 and 3. *j'''* is a tappet-crank on the rod K, inside of the chamber J, and has a forked end astride of the rod *j'*. *j'''' j''''* are tappet-nuts on the rod *j'*, one above and one below the forked end of the crank *j'''*. L is a two-way cock in the steam-inlet pipe D. *l* is a crank-rod on the outwardly-projecting end of the key to the cock L. The crank-rod *l* is slotted longitudinally and vertically, as shown at Figs. 1 and 5, and is made hollow for the reception of a spiral spring, *l'*, and is provided with a transverse

catch-pin, l'' , shown at same figure. Any equivalent of the pin l'' may be used. l''' is a knocker projecting upward from the crank l . M is a crank on the outer end of the rod K . m is a rod extending from the crank M to the crank h'' . Q is a crank extending out from the key to the cock L in a direction opposite to the crank l . The crank Q is slotted longitudinally, and otherwise constructed and provided same as crank l . R is a rod attached at its lower end to the crank M , its upper end passing through the slot in the crank Q , and provided with a hook, r , and notch r'' . T is a rod attached at its lower end to crank t on the outer end of the shaft I , its upper end passing through the slot in the crank l , and provided with a hook, t' , and notch t'' . S is a standard projecting, as shown, from the steam-inlet pipe D , and provided at its outer end with suitable bearings for the outer end of the key to the cock L . s is a lug projecting from the standard S . U is a disk on the outer end of the key to the cock L , with a segmental arc, u , cut from its periphery, (see Fig. 6,) the ends of which engage with the lug s to prevent too great rotation of the key to the cock L . V , Fig. 2, is a supplementary bottom below the bottom of the cylinder A . The bottom of the cylinder A is pierced with holes $a'' a'' a'' a'' a'' a''$, through which the water passes in being discharged to the bottom V , through which it passes by a single opening to the pipe B . W is a deflector arranged just below the entrance to the cylinder A of the steam-inlet pipe D , for the purpose of arresting and spreading the descending column of steam, when admitted, as hereinafter described.

The operation of my invention is as follows: A vacuum being formed in the cylinder A , as hereinafter described, the water flowing in through the pipe C will, in raising the valve j , rotate the shaft K by means of the tappet-crank j''' and tappets $j'''' j''''$, raising at the same time, by means of the crank M , the hook-rod R until the hook r on its upper end rises above and engages with the pin q'' in the slotted crank Q , as shown at Fig. 1, the crank Q being turned upward. At the same time the crank M also raises the rod m , thereby turning the key and closing the two-way cock h' , and preventing the air in the dome E from escaping into the cylinder A while filling with water. When the cylinder A is filled with water the valve j , dropping by its own gravity, will bring down the hook-rod R , and with it the crank Q , rotating and opening thereby the two-way cock L for the admission of steam through the pipe D to the tank A , and at the same time bringing down the rod m and opening the two-way cock h' so that water may be forced into the air-dome E through the valve H and pipe f by the pressure of the steam on the water in the cylinder A . While the tank or cylinder A is filling with water a small portion of air will enter the dome G through the pipe g , which, being heavier than steam, will settle between the steam and the upper sur-

face of the water when the steam is admitted through pipe D , thereby forming an elastic cushion between the two and a good non-conductor of heat from the steam to the water. The quantity of air admitted to the dome G may be regulated by the pet-cock g'' . The check-valve g' will prevent steam escaping through the pipe g while entering the cylinder A through the pipe D and dome G . The pressure of the steam on the water in the cylinder A will force the water therefrom through the pipe B , thereby raising the valves b'' and b^3 . The valve b'' in rising will rotate the shaft I by means of tappet-crank i , and thereby raise the rod T by means of crank t until the hook t' on its upper end rises above and is pressed in to engage with the pin l'' in the crank l by the spiral spring l' . When the water is expelled from the cylinder A the valve b'' , dropping by its own gravity, will rotate the shaft I in a direction to bring down the rod T , which, in turn, will bring down the crank l , and thereby turn the key to the cock L , and close and cut off the further passage of steam through the pipe D . The compressed air in the chamber E will now force a portion of the water therein, through the open two-way cock h' and check-valve f' , into the cylinder A , for the purpose of condensing the steam therein, and thereby producing a vacuum, when the water will again rush in through pipe C to fill the tank, as before described. The valve-chambers b and j are contracted, so as to fit their respective valves b'' and j , at their lower parts, as shown, so as to insure them moving a sufficient distance with the passage of the water through them to guarantee the working of their respective valve-gear. The valve b^3 , when the pressure of the water ceases on its under side, will drop to its seat and allow the water in upper end of the pipe B to descend slowly through the hole b^4 , and prevent the concussion to the valve-gear which occurs when the weight of the water in the said pipe is allowed to drop with its full force directly onto the valve b'' . The momentum of the water in entering the tank A is so great as to carry in a body of water often in excess of the vacuum, which, in its back action through the pipe C , will bring down the valve j so suddenly as to jar and injure the valve-gear. To prevent this the valve j^3 is seated below it in a low or short chamber, so it will close first, and the water, descending slowly through the hole j^4 in it, will allow the valve j to drop gently to its seat. When a single hole is used for the passage of the water from the bottom of the cylinder A , the water will frequently, from the whirling rotary motion produced thereby, be thrown out to the sides of the tank, leaving a cone or funnel-shaped opening, through which the steam will pass into the discharge-pipe B , and, becoming condensed therein, produce a vacuum, causing the valve j to drop and cut off steam before the water is discharged from the cylinder A . The series of holes $a'' a'' a'' a''$ will allow the water

to pass from cylinder A without producing such rotary motion of the water, as each will interfere with the continued whirl of the water produced by its fellows. When the valve b'' drops and brings down with it the rod T, the hook t' engages with the catch-pin l'' , bringing down the crank l until one side of the notch in the disk U strikes the lug s and holds the key to the cock L from rotating too far. The knocker l''' now strikes the upper end of the rod T and releases the hook t' , which is carried down to the position shown at Fig. 5 by the further motion of the valve b'' . At the same time that the notch u strikes the lug s , it will be seen by Fig. 5 that the semicircular notch r' on the rod R will engage with the catch-pin q'' and prevent the rebound of the cranks turning the key to the cock L and letting on steam. The notch r' in rod R being semicircular, the force with which the valve j raises it will easily release it from the pin q'' . The operation of the notch t'' is the same as the last described when the disk U is rotated in the opposite direction.

Claims.

1. The valve j , crank M, and shaft K, when combined and arranged to operate with the hook-rod R, crank Q, and two-way cock L,

substantially as described, and for the purpose set forth.

2. The two-way cock h' , rod m , crank M, and shaft K, when arranged to operate, with the valve j , dome E, and pipes f and f' , and valves H and h , substantially as described, and for the purpose set forth.

3. The valve b'' , crank t , shaft I, rod T, crank l , and two-way cock L, when combined and arranged to operate substantially as described, and for the purpose set forth.

4. The disk U, arranged to operate, with the two-way cock L, substantially as described, and for the purpose specified.

5. The cranks l and Q, having springs and pins, as described, when arranged, to operate in combination with hook-rods R and T, in the manner and for the purpose substantially as set forth.

6. The valves b^3 and j^3 , when arranged to operate with their respective valves b'' and j , substantially as described, and for the purpose specified.

7. The combination of the supplementary bottom V with the bottom A', having holes a' , for the purpose specified.

Witnesses: JAMES H. PATTEE,
J. J. TUNNICLIFF,
J. B. HOLLAND.