

Feb. 7, 1928.

1,658,550

L. BLACKMORE

ADJUSTABLE LIGHT SUPPORT FOR REFLECTORS

Filed July 3, 1925

2 Sheets-Sheet 1

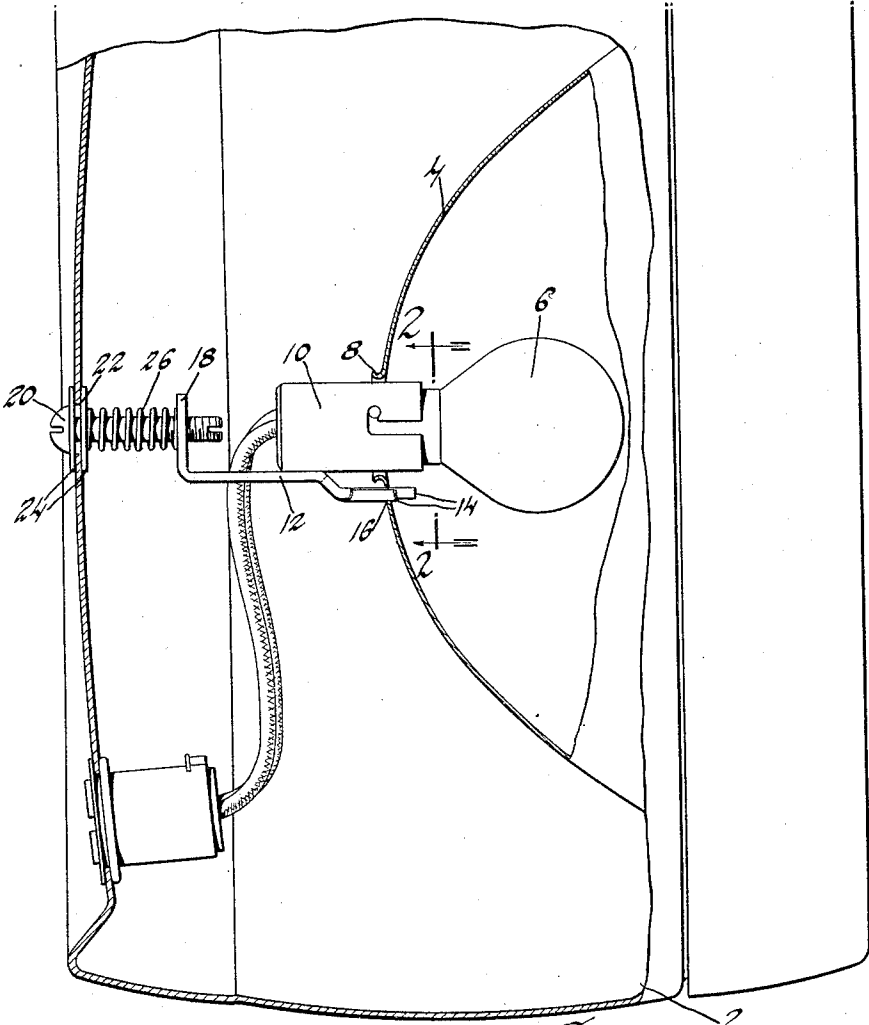

Fig. 1

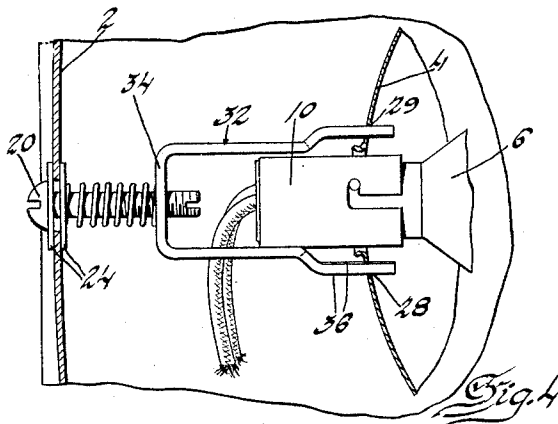

Fig. 4

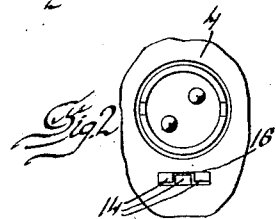

Fig. 2



Fig. 3

Inventor

Lloyd Blackmore

Feb. 7, 1928.

1,658,550

L. BLACKMORE

ADJUSTABLE LIGHT SUPPORT FOR REFLECTORS

Filed July 3, 1925

2 Sheets-Sheet 2

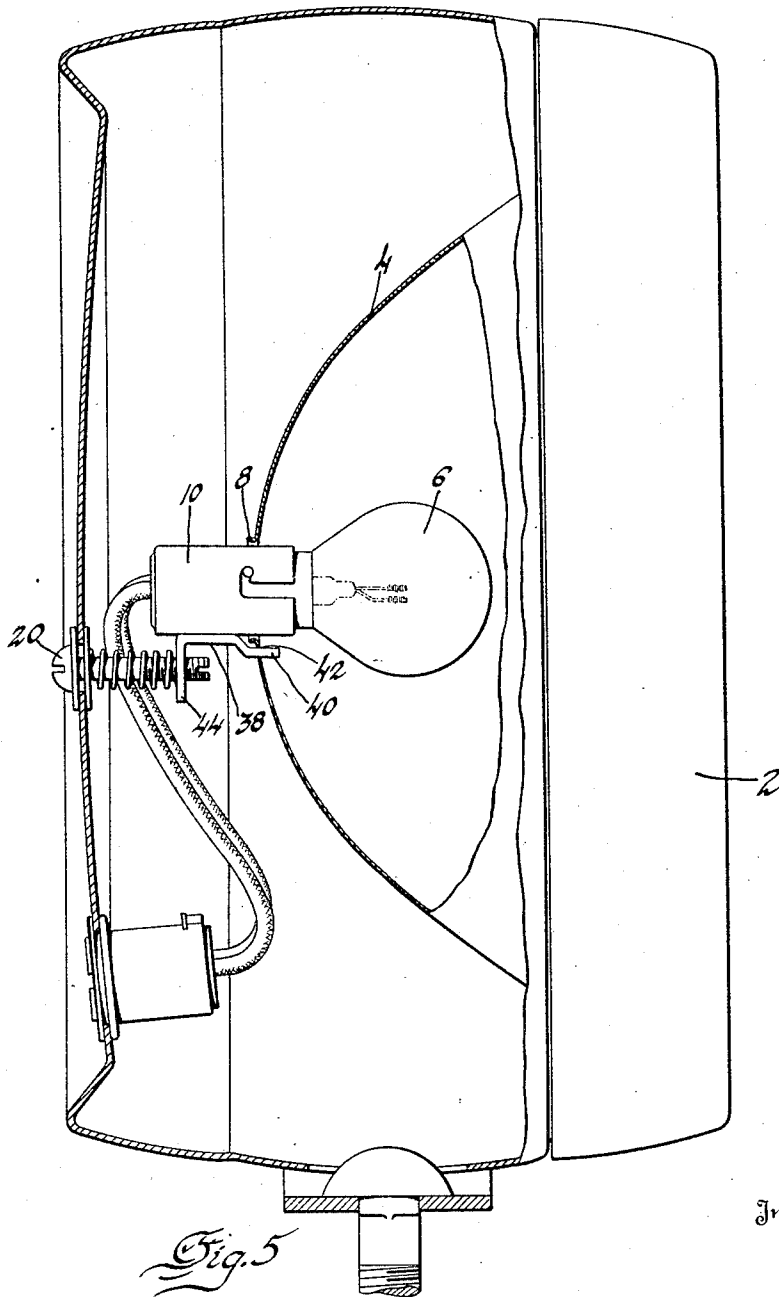

Inventor

Fig. 5

Lloyd Blackmore

UNITED STATES PATENT OFFICE.

LLOYD BLACKMORE, OF HIGHLAND PARK, MICHIGAN, ASSIGNOR TO GENERAL MOTORS CORPORATION, OF DETROIT, MICHIGAN, A CORPORATION OF DELAWARE.

ADJUSTABLE LIGHT SUPPORT FOR REFLECTORS.

Application filed July 3, 1925. Serial No. 41,334.

In the present day automobile headlight, consisting essentially of a light source and a reflector, it is necessary to provide an adjusting means which will permit considerable variation in the position of the light source in the reflector so as to secure the desired distribution of the reflected light. This is because the parts of the lamp and casing are not manufactured with sufficient accuracy nor are the filaments positioned in the bulb with sufficient precision to permit of the latter being fixed in position in the lamp.

The adjusting means which I have devised affords the required adjustments and at the same time holds the light source so securely in its adjusted position that it will not become loosened as a result of vibration of the car. It is also of very simple but sturdy construction and may be cheaply manufactured and easily assembled.

In the drawings:

Figure 1 is a fragmentary view of an automobile headlight with parts in section showing my adjustable light support in position;

Figure 2 is a section on line 2—2 of Figure 1;

Figure 3 is an enlarged view of a detail; and

Figures 4 and 5 are views corresponding to Figure 1 but showing modified forms.

Referring to Figure 1, 2 indicates an automobile headlight casing which may be of any preferred shape, while 4 indicates a reflector secured within the casing and serving to project the rays emanating from the customary light bulb shown at 6. The reflector 4 is provided with an opening 8 through which projects the socket 10 in which is mounted the light bulb. The socket fits loosely within the opening to permit of the adjustments to be later described. To the socket 10 is secured a member 12 having at its forward end spring fingers 14, shown in detail in Figures 2 and 3, which are adapted to project into aperture 16 formed in the reflector adjacent the opening 8. The spring fingers 14 normally diverge and are compressed for insertion in the aperture 16. When released they frictionally engage the edges of the aperture and serve very effectively for yieldingly mounting the socket in the reflector so as to permit longitudinal and rocking adjustment thereof while at the

same time holding the socket securely in position so that it will not become loosened as a result of vibrations of the car.

The other end of the member 12 is provided with an apertured up-turned end 18 for engagement with an adjusting means consisting of a screw 20 fitting loosely within an aperture 22 in the rear wall of the lamp casing. The screw 20 is provided with means to frictionally grip the casing so as to hold the assembly in adjusted position. This means consists of washers 24 encircling the screw and arranged one inside and one outside the casing. The spring 26 which encircles the screw, bearing at one end against the up-turned end 18 of the member 12 and at the other end against the inner washer 24 serves to frictionally grip the wall between the two washers and holds the assembly in any position of rocking adjustment. At the same time by tensioning the part 18 with respect to the screw it acts as a spring washer to hold the assembly in any position of longitudinal adjustment.

It is now apparent that by rotating the screw 20 the lightning assembly may be moved longitudinally either inwardly or outwardly with respect to the reflector, the fingers 14 sliding in the aperture 16. The whole assembly may also be rotated about the fulcrum afforded by the parts 14 and 16 and, in whatever way the assembly may be adjusted, the spring 26 will yieldingly hold it in position.

The modification shown in Figure 4 differs from that shown in the preceding figures only in that the reflector is provided with a plurality of apertures 28 and 29 in place of the single aperture 16 and a U-shaped member 32 is substituted for the member 12, the ends of the legs of the U engaging in the apertures 28 and 29 under tension; that is, the U-shaped member is slightly compressed for insertion of its ends in the apertures and its consequent tendency to expand causes it to grip the reflector. The end of each leg of the U is preferably also provided with resilient tongues 36 as in the preceding form. The adjusting screw 20 is threaded in the base 34 of the U.

In the modification shown in Figure 5 I have substituted for the member 12 of Figure 1 a member 38 provided with a portion 40 for engagement in the aperture 42 in the reflector and with a down-turned portion 44

for engagement with the adjusting screw 20. This arrangement is particularly adapted for head lamps in which there is but slight space between the reflector and the rear of the lamp casing.

If preferred, the part 40 may be slit to form spring fingers as in the other form.

I claim:

1. The combination of a reflector having an opening therein, a lamp socket adapted to support a lamp in said opening, said reflector being provided with an aperture adjacent said opening, a part secured to said lamp socket and having frictionally gripping engagement with said aperture for supporting said socket and permitting adjustment of the latter, said part being provided with an end portion extending at an angle to the main portion thereof, a lamp casing having an aperture therein, and manipulating means cooperating with said last named aperture and said end portion for effecting rocking and sliding adjustment thereof.

2. In the combination as defined by claim 1, said last named means comprising a screw having threaded engagement with said end portion and loosely fitting in the aperture in the casing, and means associated with said screw for frictionally clamping the casing to hold the parts in adjusted position.

3. The combination of a reflector having an opening therein, a light mounting adapted to support a light bulb in said open-

ing, said reflector being provided with a plurality of apertures adjacent said opening, a resilient U-shaped member secured to said mounting, the ends of the legs of the U-shaped member being adapted to engage in said apertures under tension for adjustably positioning said mounting with respect to the reflector.

4. The structure as defined by claim 3, and means engaging said U-shaped member for positively adjusting said mounting with respect to said reflector.

5. The structure as defined by claim 3, and a lamp casing enclosing said reflector and provided with an aperture, means passing loosely through said aperture and provided with devices having frictional engagement with the casing, said means engaging said U-shaped member for longitudinal as well as rocking adjustment thereof.

6. The combination of a reflector having an opening therein, a light mounting adapted to support a light bulb in said opening, said reflector being provided with an aperture, said mounting being provided with a part adapted to have resilient gripping engagement with said aperture for sliding and rocking adjustment of said mounting with respect to the reflector, said part comprising resilient tongues arranged to be placed under stress when engaged in said aperture.

In testimony whereof I affix my signature.
LLOYD BLACKMORE.