

(19) World Intellectual Property
Organization
International Bureau



(43) International Publication Date
24 February 2005 (24.02.2005)

PCT

(10) International Publication Number
WO 2005/018238 A1

(51) International Patent Classification⁷: H04N 9/67

(21) International Application Number:
PCT/IB2004/051470

(22) International Filing Date: 18 August 2004 (18.08.2004)

(25) Filing Language: English

(26) Publication Language: English

(30) Priority Data:
60/495,932 18 August 2003 (18.08.2003) US

(71) Applicant (for all designated States except US): KONINKLIJKE PHILIPS ELECTRONICS, N.V. [NL/NL]; Groenewoudseweg 1, NL-5621 BA Eindhoven (NL).

(72) Inventor; and

(75) Inventor/Applicant (for US only): JASPERS, Cornelis, A.M. [NL/NL]; P.O. Box 3001, Briarcliff Manor, New York 10510-8001 (US).

(74) Common Representative: KONINKLIJKE PHILIPS ELECTRONICS, N.V.; c/o Russell Gross P.O. Box 3001, Briarcliff Manor, New York 10510-8001 (US).

(81) Designated States (unless otherwise indicated, for every kind of national protection available): AE, AG, AL, AM, AT, AU, AZ, BA, BB, BG, BR, BW, BY, BZ, CA, CH, CN, CO, CR, CU, CZ, DE, DK, DM, DZ, EC, EE, EG, ES, FI, GB, GD, GE, GH, GM, HR, HU, ID, IL, IN, IS, JP, KE, KG, KP, KR, KZ, LC, LK, LR, LS, LT, LU, LV, MA, MD, MG, MK, MN, MW, MX, MZ, NA, NI, NO, NZ, OM, PG, PH, PL, PT, RO, RU, SC, SD, SE, SG, SK, SL, SY, TJ, TM, TN, TR, TT, TZ, UA, UG, US, UZ, VC, VN, YU, ZA, ZM, ZW.

(84) Designated States (unless otherwise indicated, for every kind of regional protection available): ARIPO (BW, GH, GM, KE, LS, MW, MZ, NA, SD, SL, SZ, TZ, UG, ZM, ZW), Eurasian (AM, AZ, BY, KG, KZ, MD, RU, TJ, TM), European (AT, BE, BG, CH, CY, CZ, DE, DK, EE, ES, FI, FR, GB, GR, HU, IE, IT, LU, MC, NL, PL, PT, RO, SE, SI, SK, TR), OAPI (BF, BJ, CF, CG, CI, CM, GA, GN, GQ, GW, ML, MR, NE, SN, TD, TG).

Declarations under Rule 4.17:

— as to applicant's entitlement to apply for and be granted a patent (Rule 4.17(ii)) for the following designations AE, AG, AL, AM, AT, AU, AZ, BA, BB, BG, BR, BW, BY, BZ, CA, CH, CN, CO, CR, CU, CZ, DE, DK, DM, DZ, EC, EE, EG, ES, FI, GB, GD, GE, GH, GM, HR, HU, ID, IL, IN, IS, JP, KE, KG, KP, KR, KZ, LC, LK, LR, LS, LT, LU, LV, MA,

[Continued on next page]

(54) Title: MODIFIED LUMINANCE WEIGHTS FOR SATURATION CONTROL

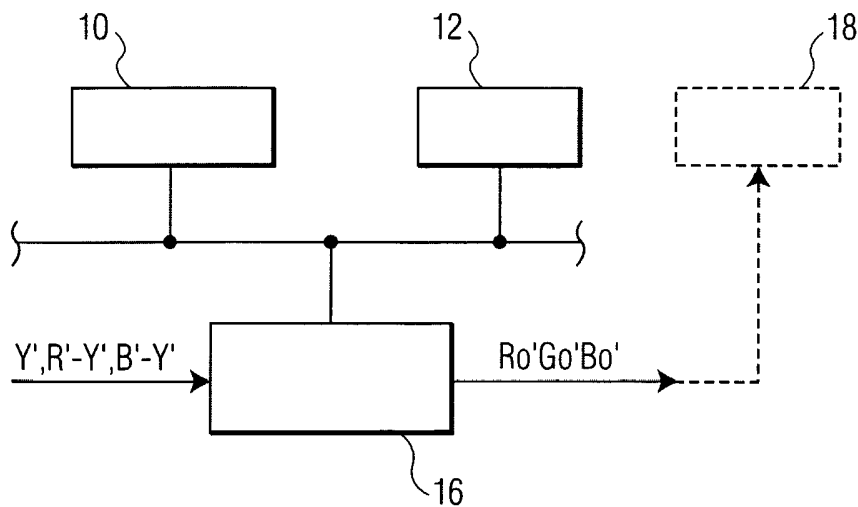

(57) Abstract: The present invention is directed to method of processing a luminance signal including predetermined weights and color difference signals. In particular, the method includes the luminance signal and the color difference signals being converted into color signals. A second luminance signal is formed from the color signals. The second luminance signal includes second weights different from the predetermined weights. The second luminance signal is subtracted from each of the color signals to produce second color difference signals. The second color difference signals are amplified by a saturation parameter to produce amplified difference signals. Further, the second luminance signal is added to each of the amplified difference signals to produce output color signals.

WO 2005/018238 A1



MD, MG, MK, MN, MW, MX, MZ, NA, NI, NO, NZ, OM, PG, PH, PL, PT, RO, RU, SC, SD, SE, SG, SK, SL, SY, TJ, TM, TN, TR, TT, TZ, UA, UG, UZ, VC, VN, YU, ZA, ZM, ZW, ARIPO patent (BW, GH, GM, KE, LS, MW, MZ, NA, SD, SL, SZ, TZ, UG, ZM, ZW), Eurasian patent (AM, AZ, BY, KG, KZ, MD, RU, TJ, TM), European patent (AT, BE, BG, CH, CY, CZ, DE, DK, EE, ES, FI, FR, GB, GR, HU, IE, IT, LU, MC, NL, PL, PT, RO, SE, SI, SK, TR), OAPI patent (BF, BJ, CF, CG, CI, CM, GA, GN, GQ, GW, ML, MR, NE, SN, TD, TG)

— as to the applicant's entitlement to claim the priority of the earlier application (Rule 4.17(iii)) for all designations

Published:

— with international search report

For two-letter codes and other abbreviations, refer to the "Guidance Notes on Codes and Abbreviations" appearing at the beginning of each regular issue of the PCT Gazette.

MODIFIED LUMINANCE WEIGHTS FOR SATURATION CONTROL

The present invention relates generally to video signal processing, and more particularly, to a method of saturation control that changes luminance weights of a luminance signal in order to provide a more balanced color picture as the level of saturation control increases.

In 1953, the first color television system was developed in the United States, which was approved by the Federal Communications Commission (FCC) for broadcasting shortly thereafter. In order to make this system backward compatible with the existing monochrome system, video information was transmitted by a luminance signal and a chrominance signal. The luminance signal provided brightness information while the chrominance signal provided color information.

The luminance signal is derived from gamma-corrected red, green and blue signals as follows:

$$Y' = 0.299R' + 0.587G' + 0.114B' \quad (1)$$

The chrominance signal is made up of color difference signals that are combined with the luminance signal to produce red, green and blue color signals that are used to produce a color picture on a display. These color difference signals specify the differences between the luminance signal and the gamma-corrected red, green and blue color signals as follows:

$$\begin{aligned} PB &= 0.492(B' - Y') \\ PR &= 0.877(R' - Y') \end{aligned} \quad (2)$$

Saturation control in color television is based on the amplification of the color difference signals with the luminance signal. As can be seen from Equation (1), the luminance signal has three predetermined weights ($YR : YG : YB = 0.299 : 0.587 : 0.114$) that determine the contribution of each of the RGB color signals. These predetermined weights were defined according the FCC standardization of 1953. It should be noted that other color television systems such as the Phase Alternation line (PAL) use these same RGB weights.

A drawback with the present color systems is that at higher levels of saturation control the brightness of the color picture is not always balanced. This is because the above-described RGB weights in Equation (1) cause a relative exaggerated increase of the

blue, red and magenta colors and a rather poor increase of the cyan and yellow colors as saturation control increases.

In view of the above, the present invention is directed to method of processing a luminance signal including predetermined weights and color difference signals. In particular, the method includes the luminance signal and the color difference signals being converted into color signals. A second luminance signal is formed from the color signals. The second luminance signal includes second weights different from the predetermined weights. The second luminance signal is subtracted from each of the color signals to produce second color difference signals. The second color difference signals are amplified by a saturation parameter to produce amplified difference signals. Further, the second luminance signal is added to each of the amplified difference signals to produce output color signals.

In one example, the output color signals may be stored. In another example, the output color signals may be displayed.

Referring now to the drawings were like reference numbers represent corresponding parts throughout:

Figure 1 is a diagram including tables comparing the saturation control using the FCC luminance weights and according to the present invention;

Figure 2 is a diagram showing one example of saturation control according to the present invention; and

Figure 3 is a diagram showing one example of a device according to the present invention.

As previously described, saturation control in color television systems is based on the amplification of the colour difference signals with a luminance signal having predetermined RGB contributions ($YR : YG : YB = 0.299 : 0.587 : 0.114$) according to the FCC standardization of 1953. A drawback with these predetermined weights is that as color saturation increases, a relative exaggerated increase of blue, red and magenta colors occur. While a rather poor increase of cyan and yellow colors occur. However, according to the present invention, by modifying the predetermined weights of the luminance signal, the brightness of the yellow and cyan color is increased providing a more balanced color picture as saturation control increases.

In order to illustrate the saturation control according to the present invention, the effect on RGB signals before display and the relative light output of the maximum of the three RGB outputs after the display will be calculated for a number of different sets of luminance weights. These results are shown in the tables of Figure 1. In Table 1, the
 5 RGB luminance weights will be according to the FCC standard, (YR : YG : YB = 0.299 : 0.587 : 0.114). In Table 2, the RGB luminance contributions will be equal, (YR : YG : YB = 0.333 : 0.333 : 0.333). In Table 3, there will be a high B-contribution, (YR : YG : YB = 0.167 : 0.167 : 0.666).

The increase in the saturation control occurs in the non-linear color difference
 10 signals after the camera gamma, as follows:

$$\begin{aligned}(R-Y)' &= \text{sat} \times (R'-Y') \\ (B-Y)' &= \text{sat} \times (B'-Y')\end{aligned}\quad (3)$$

After the saturation control, the RGB signals become:

$$\begin{aligned}R' &= \text{sat} \times (R'-Y') + Y' \\ G' &= \text{sat} \times (G'-Y') + Y' \\ B' &= \text{sat} \times (B'-Y') + Y'\end{aligned}\quad (4)$$

After a gamma ($\tilde{\alpha}$) of 2.3 of the display, the relative R"G"B" light output becomes:

$$R'' = R' \tilde{\alpha}, G'' = G' \tilde{\alpha}, B'' = B' \tilde{\alpha}\quad (5)$$

The maximum of the RGBmax" output of the display is:

$$20 \quad \text{RGBmax}'' = \max \{R'', G'', B''\}\quad (6)$$

In Tables 1-3, the increase of the relative RGBmax" output is shown. The data in the tables has been calculated according Equation 4 for the relative RGBmax' value after the saturation control and before the display. The relative RGBmax" output of the CRT display has been calculated with Equation 6.

25 Depending on the maximum allowed saturation control by the television maker, the input signals before and after the display can be compared. For a LCD display, a saturation control of 1.2 is the acceptable maximum due to the limited reach of the LCD light output, then one can compare the columns with sat=1.2 in the three tables. For a CRT (or PDP) display, a higher amount of saturation control is allowed, then one can choose between the

columns with $\text{sat}=1.4$ or $\text{sat}=2.0$. The latter will cause however a very exaggerated color reproduction.

The RGBmax'' output of the display represents the increase of the light output of the primary that has determined RGBmax'' according to Equation 6. As can be seen from
5 Table 1, the FCC luminance weights causes a more exaggerated increase in the color blue at higher levels of saturation control. As can be seen from Table 2, the increase for the colors blue, red and green is the highest. However, difference between the other colors cyan, yellow and magenta is much less at higher levels of saturation control. Therefore, a more balanced color picture is achieved at higher levels of saturation control.

10 As can be seen from Table 3, the increase for the colors red and green is the highest. Taken with the data in the other two tables, it can be determined that the primary color with the smallest luminance weight will cause the largest RGBmax'' increase at increasing levels of saturation control. Further, for the complementary color with the largest luminance weight will cause the smallest RGBmax'' at higher levels of saturation
15 control.

It should also be noted that the use of more balanced luminance weights shift hue errors toward colors that the human eye is less sensitive too. This is because as saturation control increases the RGB color having the smallest luminance contribution will have the smallest hue error. In the FCC luminance weights, blue has the smallest contribution and
20 thus will have the smallest hue error. While the opposite color yellow will have a larger hue error. Since the human eye is more sensitive to hue errors in yellow than in blue, this is a further disadvantage.

However, by using more balanced luminance weights such as in Table 2 of Figure 1, the luminance contribution of the blue color causes a larger error in blue and a smaller in
25 yellow. Since the human eye is less sensitive to hue errors in blue, the hue error can be reduced at higher saturation levels by modifying the FCC luminance weights.

One example of saturation control according to the present invention is shown in Figure 2. As can be seen, a luminance signal Y' and two color difference signals $R1f' - Y1f'$, $B1f' - Y1f'$ are processed. As previously described, the luminance signal has
30 predetermined weights ($YR : YG : YB = 0.299 : 0.587 : 0.114$) according to the FCC standardization of 1953, which are also used in other color television systems such as PAL. Further, the two color difference signals are derived from the chrominance signal. In this

example, the difference signals are in a low frequency form since these signals may be low pass filtered on the transmitter side.

In Step 2, the luminance signal Y' and two color difference signals $R' - Y'$, $B' - Y'$ are converted into color signals $R'G'B'$. The color signals $R'G'B'$ may be expressed as follows:

$$\begin{aligned} R' &= (R' - Y') + (Y' + Y_{hf}) = R' + Y_{hf} \\ G' &= (G' - Y') + (Y' + Y_{hf}) = G' + Y_{hf} \\ B' &= (B' - Y') + (Y' + Y_{hf}) = B' + Y_{hf} \end{aligned} \quad (7)$$

In Step 4, a new luminance signal Y_n' is derived from the color signals $R'G'B'$ produced in Step 2. In order to derive the new luminance signal, each of the color signals $R'G'B'$ are multiplied by a weight that is different than the luminance coefficients as defined by the FCC standardization. According to the present invention, these different weights will be selected in order to provide a more balanced color picture at higher levels of saturation control. In particular, this will enable the yellow and cyan colors to be as bright as the other colors in the picture.

In one example, the luminance weights chosen will be equal such as $(YR : YG : YB = 0.333 : 0.333 : 0.333)$. However, it should be noted that the present invention is not limited to one set of weights. For example, the red signal weight YR and green signal weight YG weight may be chosen from the range of about 0.1 to about 0.4. Further, the blue signal weight YB may be chosen from the range of about 0.2 to about 0.8. The new luminance signal Y_n' may be expressed as follows:

$$Y_n' = a \times (R' + Y_{hf}) + b \times (G' + Y_{hf}) + c \times (B' + Y_{hf}), \quad (8)$$

where a , b and c are the different luminance weights and the color signals $R'G'B'$ are defined by Equation 7.

Further, Y_n' can be rewritten as:

$$Y_n' = (a \times R' + b \times G' + c \times B') + Y_{hf} = Y_{nlf} + Y_{hf}, \quad (9)$$

where $Y_{nlf} = (a \times R' + b \times G' + c \times B')$.

In Step 4, three new color difference signals are also formed using the new luminance signal Y_n' . These new color difference signals are formed by subtracting the new luminance signal Y_n' from each of the color signals $R'G'B'$ produced in Step 2. The three color difference signals may be expressed as follows:

$$R_n' - Y_n' = (R' + Y_{hf}) - Y_n'$$

$$\begin{aligned} G_n' - Y_n' &= (G_{lf}' + Y_{hf}') - Y_n' \\ B_n' - Y_n' &= (B_{lf}' + Y_{hf}') - Y_n' \end{aligned} \quad (10)$$

In Step 6, saturation control is performed on each of the color difference signals produced in step 4. In performing this step, each of the color difference signals is amplified by a saturation parameter. The saturation parameter is usually a value equal or greater than one (1) that may vary according to the characteristics of the display device or due to user preference. Further, the saturation parameter may be predetermined or may be dynamically changed during operation.

In Step 8, the amplified difference signals from Step 6 are then converted to output color signals R_o' G_o' B_o' . These output color signals R_o' G_o' B_o' can either be stored or sent to a display device to produce a color picture. The output color signals R_o' G_o' B_o' are produced by adding the new luminance signal Y_n' to each of the amplified difference signals. The output color signals R_o' G_o' B_o' may be expressed as follows:

$$\begin{aligned} R_o' &= \text{sat} \times (R_n' - Y_n') + Y_n' \\ G_o' &= \text{sat} \times (G_n' - Y_n') + Y_n' \\ B_o' &= \text{sat} \times (B_n' - Y_n') + Y_n', \end{aligned} \quad (11)$$

where sat is the saturation parameter.

By substituting Equation 10 into Equation 11, the output color signals R_o' G_o' B_o' become:

$$\begin{aligned} R_o' &= \text{sat} \times ((R_{lf}' + Y_{hf}') - Y_n') + Y_n' = \text{sat} \times (R_{lf}' + Y_{hf}') + (1-\text{sat}) \times Y_n' \\ G_o' &= \text{sat} \times ((G_{lf}' + Y_{hf}') - Y_n') + Y_n' = \text{sat} \times (G_{lf}' + Y_{hf}') + (1-\text{sat}) \times Y_n' \\ B_o' &= \text{sat} \times ((B_{lf}' + Y_{hf}') - Y_n') + Y_n' = \text{sat} \times (B_{lf}' + Y_{hf}') + (1-\text{sat}) \times Y_n', \end{aligned} \quad (12)$$

which can be further rewritten by substituting Equation 9 into Equation 12 as follows:

$$\begin{aligned} R_o' &= \text{sat} \times (R_{lf}' + Y_{hf}') + (1-\text{sat}) \times Y_{nlf}' + (1-\text{sat}) \times Y_{hfh}' = \text{sat} \times R_{lf}' + (1-\text{sat}) \times Y_{nlf}' + Y_{hfh}' \\ G_o' &= \text{sat} \times (R_{lf}' + Y_{hf}') + (1-\text{sat}) \times Y_{nlf}' + (1-\text{sat}) \times Y_{hfh}' = \text{sat} \times R_{lf}' + (1-\text{sat}) \times Y_{nlf}' + Y_{hfh}' \\ B_o' &= \text{sat} \times (R_{lf}' + Y_{hf}') + (1-\text{sat}) \times Y_{nlf}' + (1-\text{sat}) \times Y_{hfh}' = \text{sat} \times R_{lf}' + (1-\text{sat}) \times Y_{nlf}' + Y_{hfh}' \end{aligned} \quad (13)$$

In case the method of Figure 2 is performed on signals with a full bandwidth such as Y' , $(R'-Y')$ and $(B'-Y')$, the output of Step 2 becomes:

$$\begin{aligned}
 R' &= (R' - Y') + Y' \\
 G' &= (G' - Y') + Y' \\
 B' &= (B' - Y') + Y'
 \end{aligned}
 \tag{14}$$

Further, the new luminance signal Y_n' produced in Step 4 becomes:

$$Y_n' = a \times R' + b \times G' + c \times B'
 \tag{15}$$

After performing Steps 6 and 8, the output color signals R_o' G_o' B_o' become:

$$\begin{aligned}
 R_o' &= \text{sat} \times (R' - Y_n') + Y_n' \\
 G_o' &= \text{s at} \times (G' - Y_n') + Y_n' \\
 B_o' &= \text{sat} \times (B' - Y_n') + Y_n'
 \end{aligned}
 \tag{16}$$

One example of a device according to the present invention is shown in Figure 3.

By way of example, the device may represent a television, a set-top box, a personal computer, a printer or an optical recording device such as a digital video recorder or a DVD as well as portions or combinations of these and other devices. The device includes a processor 10, memory 12, a bus 14 and one or more input/output devices 16. In case of the device being a television or a computer, it would also include a display 18.

The input/output devices 16, processor 10 and memory 12 communicate over the bus 14. Input signals including a luminance signal Y' and color difference signals $R' - Y'$, $B' - Y'$ are processed in accordance with one or more software programs stored in memory 12 and executed by processor 10 in order to generate output color signals R_o' G_o' B_o' . These output color signals R_o' G_o' B_o' can either be stored in the memory 12 or sent to the display 18 to produce a color picture.

In particular, the software programs stored in memory 12 includes the saturation control method of Figure 2. In this embodiment, the saturation control method is implemented by computer readable code executed by the processor 10. Further, the code is stored in the memory 12. In other embodiments, hardware circuitry may be used in place of, or in combination with, software instructions to implement the invention.

While the present invention has been described above in terms of specific examples, it is to be understood that the invention is not intended to be confined or limited to the examples disclosed herein. Therefore, the present invention is intended to cover various structures and modifications thereof included within the spirit and scope of the appended claims.

CLAIMS:

1. A method of processing a luminance signal including predetermined weights and color difference signals, comprising the steps of:

converting the luminance signal and the color difference signals into color signals (2);

forming a second luminance signal from the color signals, wherein the second luminance signal includes second weights different from the predetermined weights (4);

subtracting the second luminance signal from each of the color signals to produce second color difference signals (4);

amplifying the second color difference signals by a saturation parameter to produce amplified difference signals (6); and

adding the second luminance signal to each of the amplified difference signals to produce output color signals (8).

2. The method of claim 1, which further includes displaying the output color signals.

3. The method of claim 1, which further includes storing the output color signals.

4. The method of claim 1, wherein converting the luminance signal and the color difference signals into color signals (2) is performed according to the following:

$$R' = Rlf + Yhf$$

$$G' = Glf + Yhf$$

$$B' = Blf + Yhf .$$

5. The method of claim 1, wherein converting the luminance signal and the color difference signals into color signals (2) is performed according to the following:

$$R' = (R' - Y') + Y'$$

$$G' = (G' - Y') + Y'$$

$$B' = (B' - Y') + Y'.$$

6. The method of claim 1, wherein the second weights include:

a red signal weight in the range of about 0.1 to about 0.4;

a green signal weight in the range of about 0.1 to about 0.4; and

a blue signal weight in the range of about 0.2 to about 0.8.

7. The method of Claim 1, wherein the saturation parameter is a value equal or greater than one (1).
8. A device for processing a luminance signal including predetermined weights and color difference signals, comprising:
- means for converting the luminance signal and the color difference signals into color signals (2);
 - means for forming a second luminance signal from the color signals, wherein the second luminance signal includes second weights different from the predetermined weights (4);
 - means for subtracting the second luminance signal from each of the color signals to produce second color difference signals (4);
 - means for amplifying the second color difference signals by a saturation parameter to produce amplified difference signals (6); and
 - means for adding the second luminance signal to each of the amplified difference signals to produce output color signals (8).
9. The device of claim 8, which further includes means for displaying (18) the output color signals.
10. The device of claim 8, which further includes means for storing (12) the output color signals.
11. The device of claim 8, wherein the second weights include:
- a red signal weight in the range of about 0.1 to about 0.4;
 - a green signal weight in the range of about 0.1 to about 0.4; and
 - a blue signal weight in the range of about 0.2 to about 0.8.
12. The device of Claim 8, wherein the saturation parameter is a value equal or greater than one (1).

13. A memory medium including code for processing a luminance signal including predetermined weights and color difference signals, the code comprising:
- a code for converting the luminance signal and the color difference signals into color signals (2);
 - a code for forming a second luminance signal from the color signals, wherein the second luminance signal includes second weights different from the predetermined weights (4);
 - a code for subtracting the second luminance signal from each of the color signals to produce second color difference signals (4);
 - a code for amplifying the second color difference signals by a saturation parameter to produce amplified difference signals (6); and
 - a code for adding the second luminance signal to each of the amplified difference signals to produce output color signals (8).
14. The memory medium of claim 13, wherein the second weights include:
- a red signal weight in the range of about 0.1 to about 0.4;
 - a green signal weight in the range of about 0.1 to about 0.4; and
 - a blue signal weight in the range of about 0.2 to about 0.8.
15. The memory medium of claim 13, wherein the saturation parameter is a value equal or greater than one (1).
16. The memory medium of claim 13, which further includes a code for displaying the output color signals.
17. The memory medium of claim 13, which further includes a code for storing the output color signals.

1

	RGBmax'	RGBmax'	RGBmax'	RGBmax''	RGBmax''	RGBmax''
	SAT = 1.2	SAT = 1.4	SAT = 2.0	SAT = 1.2	SAT = 1.4	SAT = 2.0
R=0, G=0, B=1	1.177	1.354	1.886	1.455	2.009	4.303
R=1, G=0, B=0	1.140	1.280	1.701	1.352	1.766	3.393
R=1, G=0, B=1	1.117	1.235	1.587	1.290	1.624	2.893
R=0, G=1, B=0	1.083	1.166	1.413	1.200	1.421	2.215
R=0, G=1, B=1	1.060	1.120	1.299	1.143	1.300	1.825
R=1, G=1, B=0	1.023	1.046	1.114	1.053	1.108	1.282

2

	RGBmax'	RGBmax'	RGBmax'	RGBmax''	RGBmax''	RGBmax''
	SAT = 1.2	SAT = 1.4	SAT = 2.0	SAT = 1.2	SAT = 1.4	SAT = 2.0
R=0, G=0, B=1	1.133	1.267	1.667	1.333	1.722	3.238
R=1, G=0, B=0	1.133	1.267	1.667	1.333	1.722	3.238
R=1, G=0, B=1	1.067	1.133	1.333	1.160	1.333	1.938
R=0, G=1, B=0	1.133	1.267	1.667	1.333	1.722	3.238
R=0, G=1, B=1	1.067	1.133	1.333	1.160	1.333	1.938
R=1, G=1, B=0	1.067	1.133	1.333	1.160	1.333	1.938

3

	RGBmax'	RGBmax'	RGBmax'	RGBmax''	RGBmax''	RGBmax''
	SAT = 1.2	SAT = 1.4	SAT = 2.0	SAT = 1.2	SAT = 1.4	SAT = 2.0
R=0, G=0, B=1	1.067	1.133	1.333	1.160	1.333	1.938
R=1, G=0, B=0	1.167	1.333	1.833	1.426	1.938	4.031
R=1, G=0, B=1	1.033	1.066	1.167	1.078	1.160	1.426
R=0, G=1, B=0	1.167	1.333	1.833	1.160	1.938	4.031
R=0, G=1, B=1	1.033	1.066	1.167	1.078	1.161	1.426
R=1, G=1, B=0	1.133	1.266	1.667	1.333	1.722	3.324

FIG. 1

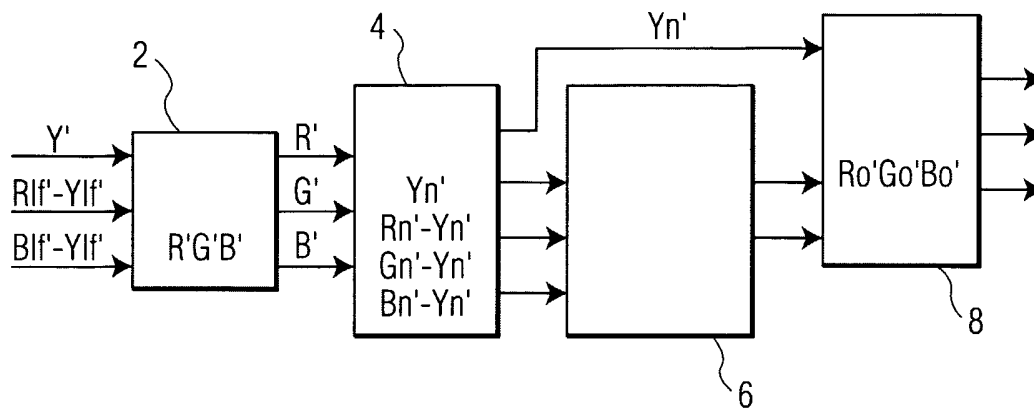

FIG. 2

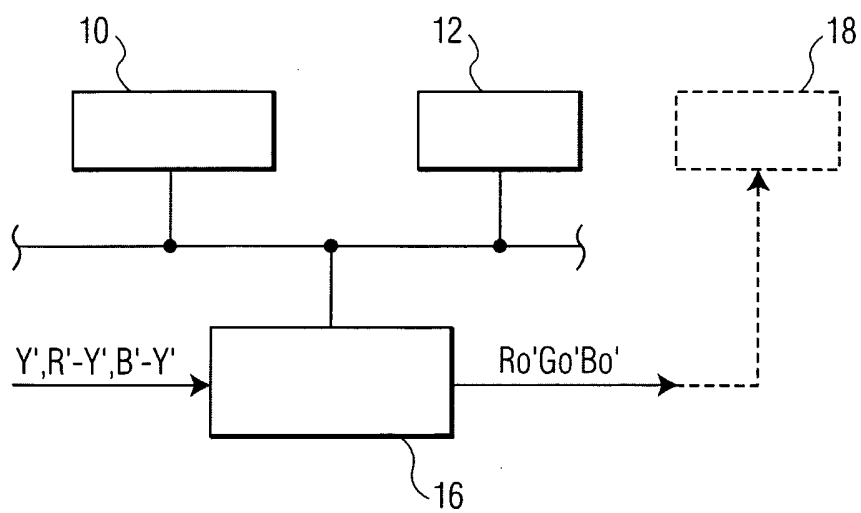

FIG. 3

INTERNATIONAL SEARCH REPORT

International Application No
PCT/IB2004/051470**A. CLASSIFICATION OF SUBJECT MATTER**
IPC 7 H04N9/67

According to International Patent Classification (IPC) or to both national classification and IPC

B. FIELDS SEARCHEDMinimum documentation searched (classification system followed by classification symbols)
IPC 7 H04N

Documentation searched other than minimum documentation to the extent that such documents are included in the fields searched

Electronic data base consulted during the international search (name of data base and, where practical, search terms used)

EPO-Internal, PAJ, WPI Data

C. DOCUMENTS CONSIDERED TO BE RELEVANT

Category *	Citation of document, with indication, where appropriate, of the relevant passages	Relevant to claim No.
A	WO 85/05718 A (MOTOROLA INC) 19 December 1985 (1985-12-19) the whole document -----	1-17
A	US 5 784 050 A (CORY MICHAEL KENNETH) 21 July 1998 (1998-07-21) abstract column 2, line 63 - line 65 -----	1-17
A	EP 0 933 952 A (MATSUSHITA ELECTRIC IND CO LTD) 4 August 1999 (1999-08-04) abstract; figures 9,11 -----	1-17
A	US 5 767 899 A (HIEDA TERUO ET AL) 16 June 1998 (1998-06-16) figures 1,15,16 column 4, line 25 - column 5, line 18 -----	1,8,13

 Further documents are listed in the continuation of box C. Patent family members are listed in annex.

* Special categories of cited documents :

- *A* document defining the general state of the art which is not considered to be of particular relevance
- *E* earlier document but published on or after the international filing date
- *L* document which may throw doubts on priority claim(s) or which is cited to establish the publication date of another citation or other special reason (as specified)
- *O* document referring to an oral disclosure, use, exhibition or other means
- *P* document published prior to the international filing date but later than the priority date claimed

- *T* later document published after the international filing date or priority date and not in conflict with the application but cited to understand the principle or theory underlying the invention
- *X* document of particular relevance; the claimed invention cannot be considered novel or cannot be considered to involve an inventive step when the document is taken alone
- *Y* document of particular relevance; the claimed invention cannot be considered to involve an inventive step when the document is combined with one or more other such documents, such combination being obvious to a person skilled in the art.
- * & * document member of the same patent family

Date of the actual completion of the international search

2 November 2004

Date of mailing of the international search report

19/11/2004

Name and mailing address of the ISA

European Patent Office, P.B. 5818 Patentlaan 2
NL - 2280 HV Rijswijk
Tel. (+31-70) 340-2040, Tx. 31 651 epo nl,
Fax: (+31-70) 340-3016

Authorized officer

Güvener, C

INTERNATIONAL SEARCH REPORT

 International Application No
 PCT/JP2004/051470

Patent document cited in search report	Publication date	Patent family member(s)	Publication date
WO 8505718	A	19-12-1985	EP 0197940 A1 22-10-1986
			WO 8505718 A1 19-12-1985
			JP 61502439 T 23-10-1986

US 5784050	A	21-07-1998	NONE

EP 0933952	A	04-08-1999	JP 3134660 B2 13-02-2001
			JP 7288837 A 31-10-1995
			EP 0933952 A2 04-08-1999
			DE 69515193 D1 06-04-2000
			DE 69515193 T2 19-10-2000
			DE 69532212 D1 08-01-2004
			DE 69532212 T2 09-09-2004
			EP 0677972 A2 18-10-1995
			US 5619280 A 08-04-1997
			US 5691779 A 25-11-1997

US 5767899	A	16-06-1998	JP 6197363 A 15-07-1994
			JP 6197360 A 15-07-1994
			US 5548330 A 20-08-1996
