



- (51) International Patent Classification: *G02B 21/00* (2006.01) *G01B 9/04* (2006.01)
- (21) International Application Number: PCT/US2013/025612
- (22) International Filing Date: 11 February 2013 (11.02.2013)
- (25) Filing Language: English
- (26) Publication Language: English
- (30) Priority Data: 61/597,682 10 February 2012 (10.02.2012) US
- (71) Applicant: **THE BOARD OF TRUSTEES OF THE LE-LAND STANFORD JUNIOR UNIVERSITY** [US/US]; Office of Technology Licensing, 1705 El Camino Real, Palo Alto, CA 94306-1106 (US).
- (72) Inventors: **PRAKASH, Manu**; Office of Technology Licensing, 1705 El Camino Real, Palo Alto, CA 94306-1106 (US). **CYBULSKI, James, Stanley**; Office of Technology Licensing, 1705 El Camino Real, Palo Alto, CA 94306-1106 (US). **CLEMENTS, James, C.**; Office of Technology Licensing, 1705 El Camino Real, Palo Alto, CA 94306-1106 (US).
- (74) Agents: **BUCKINGHAM, David, K.** et al.; Shay Glenn LLP, 2755 Campus Drive, Suite 210, San Mateo, CA 94403 (US).
- (81) Designated States (unless otherwise indicated, for every kind of national protection available): AE, AG, AL, AM, AO, AT, AU, AZ, BA, BB, BG, BH, BN, BR, BW, BY, BZ, CA, CH, CL, CN, CO, CR, CU, CZ, DE, DK, DM, DO, DZ, EC, EE, EG, ES, FI, GB, GD, GE, GH, GM, GT, HN, HR, HU, ID, IL, IN, IS, JP, KE, KG, KM, KN, KP, KR, KZ, LA, LC, LK, LR, LS, LT, LU, LY, MA, MD, ME, MG, MK, MN, MW, MX, MY, MZ, NA, NG, NI, NO, NZ, OM, PA, PE, PG, PH, PL, PT, QA, RO, RS, RU, RW, SC, SD, SE, SG, SK, SL, SM, ST, SV, SY, TH, TJ, TM, TN, TR, TT, TZ, UA, UG, US, UZ, VC, VN, ZA, ZM, ZW.
- (84) Designated States (unless otherwise indicated, for every kind of regional protection available): ARIPO (BW, GH, GM, KE, LR, LS, MW, MZ, NA, RW, SD, SL, SZ, TZ, UG, ZM, ZW), Eurasian (AM, AZ, BY, KG, KZ, RU, TJ, TM), European (AL, AT, BE, BG, CH, CY, CZ, DE, DK, EE, ES, FI, FR, GB, GR, HR, HU, IE, IS, IT, LT, LU, LV, MC, MK, MT, NL, NO, PL, PT, RO, RS, SE, SI, SK, SM, TR), OAPI (BF, BJ, CF, CG, CI, CM, GA, GN, GQ, GW, ML, MR, NE, SN, TD, TG).

[Continued on next page]

(54) Title: OPTICAL DEVICE

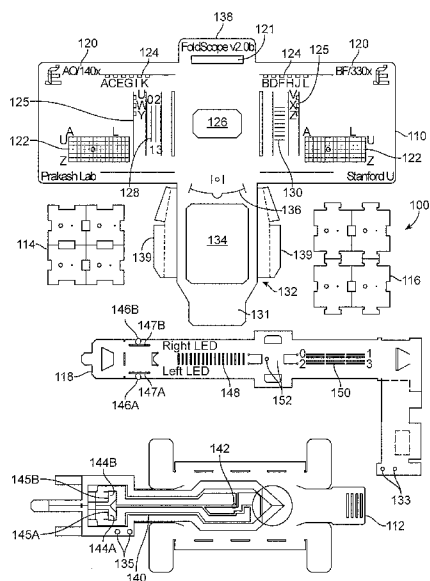

FIG. 1

(57) Abstract: An optical device, such as a microscope, is disclosed that can be assembled from flat materials. The optical device can be assembled via a series of folds of a flat material. The optical microscope can include a stage for supporting a sample, an optic stage, and a light source. The optic stage can include one or more lenses. The optical microscope can be capable of obtaining simultaneous images from different forms of microscopy. The optical microscope may have bright field and filter field viewing capabilities wherein a user shifts from bright field to filter field by lateral movement of the stage containing a lens and a light source that cooperate to provide either the bright field or the filter field.





---

**Published:**

— with international search report (Art. 21(3))

— before the expiration of the time limit for amending the claims and to be republished in the event of receipt of amendments (Rule 48.2(h))

**OPTICAL DEVICE****CROSS REFERENCE TO RELATED APPLICATIONS**

5 [0001] This application claims the benefit under 35 U.S.C. 119 of U.S. Patent Application No. 61/597,682, filed February 10, 2012, titled "MULTI MODAL OPTICAL MICROSCOPE". This application is herein incorporated by reference in its entirety.

**INCORPORATION BY REFERENCE**

10 [0002] All publications and patent applications mentioned in this specification are herein incorporated by reference to the same extent as if each individual publication or patent application was specifically and individually indicated to be incorporated by reference.

**STATEMENT REGARDING FEDERALLY SPONSORED RESEARCH OR DEVELOPMENT**

15 [0003] After filing U.S. Patent Application No. 61/597,682 on February 10, 2012 funding was received from the C-Idea grant program at Stanford, which is based on an NIH Grant (Grant1 RC4 TW008781-01.)

**FIELD**

20 [0004] The present invention relates generally to diagnostic optical devices, such as microscopes.

**BACKGROUND**

25 [0005] An optical instrument is an instrument used to move light along a specified path or paths. Microscopes are common, general-purpose optical instruments. Other optical instruments include interferometers and spectrophotometers.

[0006] Microscopes are generally used to view objects that are too small to be seen by the unaided eye. Optical microscopes use visible light and a system of lenses to magnify images of small objects. Optical microscopes are used in observing small structures, determining pathology and diagnosing disease.

30 [0007] There are two basic configurations of the conventional optical microscope, the simple (one lens) and compound (many lenses). There are also several different types of microscopy including brightfield, darkfield, fluorescence, and other forms. Each of these forms of microscopy are performed individually and one at a time. High magnification optical  
35 microscopes are often heavy and take up much volume.

[0008] There is a need for improved optical instruments to better diagnose pathologies and disease.

**SUMMARY OF THE DISCLOSURE**

5 [0009] In some embodiments an optical device is provided. The optical devices can include a first stage for supporting a sample and a second stage engaged with the first stage and movable relative to the first stage, the second stage including an optic, the optic having a distance of less than about 3 mm from the sample to the opposite side of the optic. In some embodiments the optical device is an optical microscope. In some embodiments the optical device is an  
10 interferometer or spectrophotometers. In some embodiments the second stage can be movable laterally relative to the first stage such that the optic can be positioned over a desired location on the sample.

[00010] In some embodiments the first stage is configured to receive a substrate containing the sample. In some embodiments the first stage includes a slot shaped to receive the substrate.  
15 In some embodiments the substrate is a glass slide. In some embodiments the glass slide includes a portion treated with a reagent to interact with the sample. In some embodiments the sample is supported directly on the first stage. In some embodiments the first stage includes a sample area comprising a reagent to react with the sample.

[00011] In some embodiments the optical device includes an illumination stage comprising a  
20 light source. The illumination stage can be engaged with the first stage and second stage with the illumination stage movable with the second stage. The light source can be positioned adjacent to the first stage to facilitate viewing the sample using the optic.

[00012] In some embodiments the light source is on one side of the first stage and the optic is spaced apart from the opposite side of the first stage a distance between the light source and the  
25 side of the optic farthest from the first stage is less than about 5 mm. In some embodiments the light source is on one side of the first stage and the optic is spaced apart from the opposite side of the first stage a distance between the light source and the side of the optic farthest from the first stage is from about 1 mm to about 20 mm.

[00013] In some embodiments the light source includes one or more light-emitting diodes  
30 (LEDs). In some embodiments the LED is white to provide a full-spectrum color image of the sample in bright-field. In some embodiments the LED is blue to provide light of an appropriate wavelength for fluorescence imaging. In some embodiments the LED has an output power suitable to project an image of the sample. In some embodiments the LED has a power suitable to illuminate the sample so that a user's eye may perceive the image of the sample. In some

embodiments the LEDs have power suitable so that a user may perceive multiple simultaneous images of the sample.

[00014] In some embodiments the optical device includes an illumination stage with an aperture. In some embodiments the illumination stage includes an aperture having a diameter of about 1/4 to about 2/3 of the diameter of the substantially spherical lens. In some embodiments the optical microscope includes an illumination stage with an element for modifying the profile of the light from the LED, such as a condenser, diffuser, light shaping diffuser, polycarbonate light shaping filter, etc. In some embodiments, optical microscope has an illumination stage that provides Kohler illumination.

10 [00015] In some embodiments the optical device is manufactured from a flat material that includes the first stage and second stage. In some embodiments a single material piece provides the first stage and second stage. In some embodiments the flat material comprises one or more of paper, polymer, and metal.

15 [00016] In some embodiments a power source is provided with the optical microscope. The power source can engage with the illumination stage and is configured to provide power to the light source.

[00017] In some embodiments the microscope optic comprises a substantially spherical ball lens. In some embodiments the substantially spherical ball lens has a diameter of less than about 2,500  $\mu\text{m}$ . In some embodiments the spherical ball lens has a diameter of about 1,000  $\mu\text{m}$  to about 2,500  $\mu\text{m}$ . In some embodiments the spherical ball lens has a diameter of about 300  $\mu\text{m}$  to about 1,000  $\mu\text{m}$ . In some embodiments the spherical ball lens has a diameter of about 100  $\mu\text{m}$  to about 300  $\mu\text{m}$ . In some embodiments the spherical lens has a diameter of about 200  $\mu\text{m}$  to about 1,000  $\mu\text{m}$ .

25 [00018] In some embodiments the spherical lens has an effective aperture of less than the diameter of the spherical lens. In some embodiments the aperture is about 1/4 to about 2/3 of the diameter of the spherical lens. In some embodiments the spherical ball lens has an aperture diameter of about 1/4 to 1/3 the lens diameter. In some embodiments the spherical lens has an aperture diameter of about 1/3 to 1/2 the lens diameter. In some embodiments the spherical lens has an aperture diameter of about 1/2 to 2/3 the lens diameter. In some embodiments half-ball spherical lenses can be used. In some embodiments a Wallston doublet lens is utilized. The Wallston doublet lens can be composed of multiple half ball lenses. In some embodiments a Gradient Index lens is used.

30 [00019] In some embodiments the optical microscope is manufactured from a flat material that includes the first stage, second stage, and illumination stage. In some embodiments, the optical microscope is manufactured in a single instance. In some embodiments, a series of folds

produce the final configuration of the microscope. The optical microscope can have an optical alignment of the illumination stage, first stage, and second stage achieved passively by separating and folding the flat material. The optical alignment can have an accuracy of about 10 microns or less.

5 [00020] In some embodiments, the folding accuracy is accomplished by geometrical features cut in flat material that act as kinematic couplings thus providing a self-alignment. In some embodiments, self-alignment is further improved by providing structural closed loops in folding steps.

10 [00021] In some embodiments, the optical microscope can have an integrated microfluidic channel for bringing samples directly to the microscope lens.

[00022] In some embodiments, the optical microscope can be incinerated after one use safely and thus can be used with infected samples.

[00023] In some embodiments, the entire microscope is disposable after single or multiple uses.

15 [00024] In some embodiment, a waveguide is utilized to channel light from the light source to other optical components.

[00025] In some embodiments the second stage of the optical microscope includes an opening with the lens in the opening.

20 [00026] In some embodiments the microscope has a magnification of about 100X to 200X. In some embodiments the microscope has a magnification of about 200X to 500X. In some embodiments the microscope has a magnification of about 500X to 1,500X. In some embodiments the microscope has a magnification of about 1,500X to 2,500X. In some embodiments the microscope has a magnification of greater than about 300X. In some embodiments the microscope has a magnification of greater than about 140X. In some  
25 embodiments the microscope has a magnification of greater than about 1000X.

[00027] In some embodiments the microscope has a resolution of about 2.0 to 3.0 microns. In some embodiments the microscope has a resolution of about 1.5 to 2.0 microns. In some embodiments the microscope has a resolution of about 1.0 to 1.5 microns. In some embodiments the microscope has a resolution of less than about 1.0 microns. In some embodiments the  
30 microscope has a resolution of about 0.88 to 1.0 microns. In some embodiments the microscope has a resolution of about 0.6 to 0.88 microns. In some embodiments the microscope has a resolution of 0.2 to 0.5 microns.

[00028] In some embodiments the first stage for supporting the sample comprises a diagnostic coating for providing a visual indication to a user through the optical microscope of a presence  
35 of a diagnostic target. In some embodiments the visual indication is viewed using the optic. In

some embodiments the diagnostic target is a disease, parasite, bacteria, or disorder detectable in a bodily fluid.

[00029] In some embodiments the optic includes an array of lenses. In some embodiments the array of lenses simultaneously shows one or more bright field images and one or more

5 fluorescence images. In some embodiments the array of lenses includes four or more lenses.

[00030] In some embodiments the optical microscope is a bright field microscope. In some embodiments a colored LED and/or light filter is used and the optical microscope is a fluorescence microscope, polarization microscope, phase contrast microscope, etc.

[00031] In some embodiments the optical microscope has bright field and filter field viewing capabilities wherein a user shifts from bright field to filter field by lateral movement of the second stage and the light source that cooperate to provide either the bright field or the filter field.

[00032] In some embodiments the optical microscope includes a marking aperture on the second stage configured to allow a user to identify and indicate a target location on the sample by marking the first stage through the marking aperture on the second stage such that a second user can align the optical microscope to view the target location. In some embodiments, an optimal aperture is utilized for the series of lenses used in the microscope in order to minimize the imaging artifacts.

[00033] In some embodiments, the optical microscope includes a tool for cleaning debris from the lens. The cleaning tool can be comprised of a glass slide with a piece of lens paper attached to the surface.

[00034] Methods for using optical microscopes are disclosed herein. The methods can include engaging a first portion of an optical microscope configured to support a sample with a second portion of an optical microscope having a lens; placing a sample on the first portion of the optical microscope; adjusting the lens by moving the second portion of the optical microscope having the lens relative to the first portion of the optical microscope to focus on the sample; and viewing the sample. In some embodiments during the adjusting step the optical microscope has an optical path distance of less than about 3 mm from the sample to the opposite side of the optic.

[00035] In some embodiments before the adjusting step or the viewing step is a step of placing a portion of the microscope against a user's eyebrow. In some embodiments viewing the sample comprises projecting an image of a portion of the sample. In some embodiments adjusting the lens includes moving the second portion relative to the first portion in an out-of-plane direction from a distance of about 5 $\mu$ m to about 625 $\mu$ m. In some embodiments viewing

the sample comprises buckling the second portion to adjust the distance between the lens on the second portion and the sample.

[00036] In some embodiments before viewing the sample is reacted with a reagent. In some embodiments viewing the sample comprises testing the sample for a disease.

5 [00037] In some embodiments the methods include, before engaging, removing the first portion and the second portion form a single piece of a flat material. In some embodiments engaging includes assembling the optical microscope from a flat material. In some embodiments assembly of the optical microscope involves origami or folding of a flat sheet of material

10 [00038] In some embodiments, the sample is reacted to a reagent already deposited in the sample holding stage via a microfluidic network embedded in the sample holding stage. In some embodiments, the reagent is dried for preservation. In some embodiments, the reagent is wet.

[00039] In some embodiments an optical microscope is provided including a stage; a lens; and a light source. The optical microscope having bright field and filter field viewing capabilities wherein a user shifts from bright field to filter field by lateral movement of the stage containing a lens and a light source that cooperate to provide either the bright field or the filter field. In some  
15 embodiments the lateral movement of the stage to move between bright field and filter field is less than 10 mm. In some embodiments the lens can be engaged a strip having tabs with the strip configured to allow a user to slide the tabs to buckle the strip or adjust the focal length. In some embodiments sliding the tabs attached to the lens focuses the image or moves the lens closer to  
20 the user's eye.

[00040] In some embodiments an optical microscope is provided, including a stage; a lens; a light source; and an enclosure having an enclosed volume of 70 cubic centimeters or less which contains the stage, lens and light source. In some embodiments the enclosed volume is 175 millimeters x 70 millimeters x 5.7 millimeters. In some embodiments the optical microscope  
25 further comprises a container configured to store more than twenty optical microscopes within a volume of 1,400 cubic centimeters or less. In some embodiments the container configured to store a range of 20-50 optical microscopes.

[00041] In some embodiments, the lens can be cleaned by inserting a slide with lens paper attached to the surface and panning the second stage in circles over the lens paper so that the lens  
30 paper brushes off contaminants from the surface of the lens.

In some embodiments, optical instruments including interferometers and spectrophotometers are constructed using the principles disclosed herein to achieve a desired beam path.

#### BRIEF DESCRIPTION OF THE DRAWINGS

[00042] The novel features of the invention are set forth with particularity in the claims that  
35 follow. A better understanding of the features and advantages of the present invention will be

obtained by reference to the following detailed description that sets forth illustrative embodiments, in which the principles of the invention are utilized, and the accompanying drawings of which:

- [00043] FIG. 1 illustrates the components for assembly into an exemplary optical microscope.
- 5 [00044] FIG. 2A illustrates a top view of an exemplary optical microscope.
- [00045] FIG. 2B illustrates a cross-sectional view of the optical microscope of FIG. 2A.
- [00046] FIG. 3 illustrates different embodiments of optical microscopes.
- [00047] FIG. 4 illustrates an optical microscope in accordance with an embodiment.
- [00048] FIGS. 5A-E illustrate schematic examples of optical microscopes at various assembly  
10 stages.
- [00049] FIGS. 5F-G are various images produced by a conventional microscope compared to images taken with an optical microscope in accordance with embodiments.
- [00050] FIGS. 6A and 6B illustrate examples of optical microscopes prior to folding in accordance with various embodiments.
- 15 [00051] FIGS. 7A and 7B illustrate data for the accuracy and repeatability, respectively, for folding and unfolding an optical microscope in accordance with embodiments.
- [00052] FIG. 8A illustrates an exemplary optical path of an optical microscope in accordance with an embodiment.
- [00053] FIG. 8B is a schematic illustration of an optical path for an optical microscope in  
20 accordance with an embodiment.
- [00054] FIG. 9A illustrates the magnification obtained versus various lens radii for different refractive index values.
- [00055] FIG. 9B illustrates the third order spherical aberration versus ball lens radius.
- [00056] FIG. 10 illustrates focusing metric versus the distance between the lens and image for  
25 RMS spot size ( $RSS$ ), inverse Strehl ratio ( $1/SR$ ), and ratio of spot size to Strehl ratio ( $RSS/SR$ ).
- [00057] FIG. 11A illustrates the normalized optical aperture radius versus magnification for various radii and refractive index values. FIG. 11B illustrates the resolution versus magnification for various radii and refractive index values.
- [00058] FIGS. 12A-12B illustrate calculations for the optimal aperture radius and resolution,  
30 respectively, as a function of lens radius, refractive index, and incident light wavelength.
- [00059] FIG. 13 is a graph of resolution versus aperture radius for various metrics.
- [00060] FIG. 14 is a graph of the filter transmission versus wavelength for various filter types.
- [00061] FIGS. 15A and 15B are images of malaria samples observed with and without a diffuser.

- [00062] FIG. 16A illustrate three different LED light sources with and without a condenser. FIG. 16B illustrates the intensity of a LED light source.
- [00063] FIG. 17A is a model of the ray tracing for a 0.3 mm spherical ball lens.
- [00064] FIG. 17B a model of the RMS spot size for off-axis rays.
- 5 [00065] FIG. 17C is a model of an RMS spot radius field map.
- [00066] FIG. 17D is a model of a Strehl Ratio field map.
- [00067] FIG. 18 illustrates an image of 1  $\mu\text{m}$  polystyrene beads using a 300  $\mu\text{m}$  ball lens and an aperture size of about 150  $\mu\text{m}$ .
- [00068] FIG. 19A illustrates a bright field image of 1  $\mu\text{m}$  polystyrene beads. FIG. 19B  
10 illustrates a fluorescent image of 2  $\mu\text{m}$  polystyrene beads. FIG. 19C illustrates a plot of intensity versus distance. FIG. 19D illustrates an image of polystyrene beads along with a 2D-Fourier transform showing the power spectrum of the threshold image and spatial frequency detail.
- [00069] FIG. 20A illustrates a schematic for utilizing a refraction ball lens for projection microscopy with ray-tracing for half of a lens. FIG. 20B illustrates a projection illuminated  
15 through water containing Fluorescene.
- [00070] FIG. 21A is a projected image of a mosquito proboscis at an effective magnification of 1500X. FIG. 21B is a projected image of red blood cells at an effective magnification of 3000X.
- [00071] FIG. 22A is a picture of a single ball lens optical microscope submerged under water  
20 in accordance with an embodiment.
- [00072] FIG. 22B is a picture of a single ball lens optical microscope projecting an image on the retina of a user in accordance with an embodiment.
- [00073] FIG. 22C is a picture of a single ball lens optical microscope projecting an image on a flat surface in accordance with an embodiment.
- 25 [00074] FIG. 23A is an image produced by a single ball lens optical microscope in accordance with an embodiment of a ring stage malaria parasite *Plasmodium Falciparum* in a thin blood smear stained with Giemsa blue.
- [00075] FIG. 23B is an image produced by a single ball lens optical microscope in accordance with an embodiment of *Trypanosom Cruzi* in thin blood smear stained with Giemsa.
- 30 [00076] FIG. 23C is an image produced by a single ball lens optical microscope in accordance with an embodiment of Giardia stained with Giemsa.
- [00077] FIG. 23D is an image produced by a single ball lens optical microscope in accordance with an embodiment of sickle-shaped red blood cells.
- [00078] FIG. 23E is an image produced by a single ball lens optical microscope in accordance  
35 with an embodiment of gram positive and gram negative bacteria.

[00079] FIG. 23F is an image produced by a single ball lens optical microscope in accordance with an embodiment of *Leishmania donovani* stained with Giemsa.

[00080] FIG. 23G is an image produced by a single ball lens optical microscope in accordance with an embodiment of *Burgia XX* stained with Giemsa in a thin blood smear.

5 [00081] FIG. 23H is a schematic illustration of a 3x3 lens array with different modalities embedded in an optical microscope in accordance with an embodiment.

[00082] FIG. 23I illustrates a portion of microscopes with nine (3x3), four (2x2), and 2 parallel optical paths in accordance with various embodiments.

[00083] FIG. 23J are bright field images of human blood cells produced by an optical  
10 microscope in accordance with an embodiment produced by a 3x3 array of lenses

[00084] FIG. 23K are images produced by a single ball lens optical microscope in accordance with an embodiment of a pine seed using bright field and polarization microscopy, respectively.

[00085] FIG. 23L are images produced by a single ball lens optical microscope in accordance with an embodiment of multi-fluorescence images of 2  $\mu\text{m}$  polychromatic beads.

15 [00086] FIG. 24A is an image produced by a single ball lens optical microscope in accordance with an embodiment of human chromosomes.

[00087] FIG. 24B is an image produced by a single ball lens optical microscope in accordance with an embodiment of a DNA/RNA stain.

[00088] FIG. 24C is an image produced by a single ball lens optical microscope in accordance  
20 with an embodiment of a spinal cord.

[00089] FIG. 24D is an image produced by a single ball lens optical microscope in accordance with an embodiment of skeletal muscle.

[00090] FIG. 25A is a schematic illustration of a person stepping on a single ball lens optical microscope. FIG. 25B shows the undamaged optical microscope after being stepped on.

25 [00091] FIG. 26 illustrates optical microscopes cut using a laser in accordance with embodiments.

### DETAILED DESCRIPTION

[00092] Optical devices and methods for using optical devices, such as microscopes are  
30 disclosed herein. The optical devices disclosed herein can be assembled from a flat material. The flat material can include one or more lenses, a sample support, illumination sources, and control electronics. The optical devices can be an optical microscope, interferometer, and spectrophotometers. The optical devices can be designed and assembled based on Origami principles and optical design principles. For example, the individual components of the optical

devices can be designed based on Origami principles. The components can be designed to facilitate assembly and alignment of the optical device.

5 [00093] A microscope can be a critical tool for disease diagnostics, especially in resource poor settings around the world. Conventional microscopes were designed as general-purpose research tools. Conventional microscopes are costly and not designed with portability in mind.

Traditional microscopes are also prone to failure in harsh field conditions since they are complex three-dimensional objects that are costly, bulky and require regular maintenance for optimal performance. In addition, traditional optical instruments require significant alignment post assembly.

10 [00094] The optical devices disclosed herein can be assembled in the field from a flat material and assembled to achieve the optical alignment. The achievement of the optical alignment through folding and engagement of the components can be referred to as passive alignment. Passive alignment can be achieved through kinematic constraints and structural loops. The optical devices and individual components of the optical can be shaped to facilitate passive  
15 alignment. Passive alignment great reduces the costs associated with the optical devices and allows for the optical devices to be assembled in environments without the resources for assembling and aligning a conventional optical device, such as an optical microscope.

[00095] The components of the optical microscope can be formed, printed, or applied on the flat flexible substrate. Examples of flat materials include paper, thin metal, polymers, paper  
20 coated with polymers, polyamide, Flex PCBs, etc. The flat material can be flexible and is not limited to a planar configuration.

[00096] In some embodiments other optical instruments can be constructed using the folding principles disclosed herein to achieve a desired optical or beam path in 3 dimensions. Examples of optical instruments include interferometers, spectrophotometers, and other optical  
25 instruments.

[00097] The optical devices can be assembled from the flat material using a series of cutting and folding steps. The optical microscopes disclosed herein can be designed to self-align due to kinematic constraints present in how the optical microscope is assembled from the flat materials. The optical microscope can be designed with folds and mating stages that self align the one or  
30 more lenses with the sample support and any illumination sources when assembled. Mechanical components such as a panning and focus stage can be implemented as flexure mechanisms manufactured by folding paper. The panning stage can allow for movement in the X-Y direction to position the optic over any portion of a sample. For a 2 cm by 2 cm sample the panning stage can include a travel distance of 2 cm by 2 cm.

[00098] The optical device can be a multi-modal microscope implementing one or more of bright field, multi-fluorescence, polarization, phase contrast, and projection microscopy. The optical microscope can include a filter for fluorescence and polarization modalities. For projection microscopy the optical microscope includes a light source with a power suitable to project an image. For example, the light source may consume 800mA of electrical current at 3.7V.

[00099] The sample can be viewed through the optic. In some embodiments the user can position the optical microscope close to their face, such that the optic is located about 5 cm or less from the user's retina. In some embodiments the optical microscope can project an image. For example, the image can be projected on a flat surface such as a screen. Alternatively, the optical microscope can use a screen designed to conform to the shape of the Petzval surface of the lens to eliminate field curvature in the projected image.

[00100] The optical microscope can include an array of lenses. The lenses can have different sizes and magnifications. The lenses in the array can also be used to provide images of different modalities simultaneously, e.g. two different fluorescence images or a bright field image and a fluorescence image. The array of lenses can be provided in a side by side arrangement. The multiple lenses can be paired with one or more light sources. The array of lenses can be arranged in a grid, e.g. in a 3x3 grid arrangement.

[00101] The optical microscopes can have an optical path that is much shorter than conventional microscopes. For example, the optical path can include the distance between the light source and the opposing side of the lens. In some embodiments the distance between the light source and the opposing side of the optic or lens is from about 1 mm to about 20 mm. In some embodiments the optical path is less than about 5 mm. In some embodiments the optical path is less than about 3 mm. The short optical path allows for the microscope to be a much smaller vertical height, assuming a vertical optical path, in comparison to traditional optical microscopes. The shorter vertical height requires less structural support and less material, thereby decreasing manufacturing costs. In some embodiments the optical path between the sample and the opposing side of the optic is less than about 3 mm. In some embodiments the optical path between the sample and the opposing side of the optic is less than about 2 mm or less than about 1 mm. These short optical paths can allow for illuminating the sample with a much lower power light source or lower amount of light versus conventional microscopes.

[00102] Unlike a traditional microscope, the entire optics and illumination stage can be panned across the surface of the sample slide, which can be fixed in a single location. The optical microscopes disclosed herein can have a lens and light source that are movable relative to the sample or sample stage. An optic stage can include a support for the lens. The light source

can be integrated with a separate stage, such as an illumination stage. The optic stage and illumination stage can be engaged such that they move together. The lens can move along above the sample along an x-axis and y-axis to observe different areas of the sample. In addition the vertical distance, e.g. along a z-axis, between the lens and sample can be adjusted.

5 [000103] The optical microscopes disclosed herein can be used for a variety of applications. The optical microscopes can be used for diagnostic applications such as testing for a disease, parasite, bacteria, or disorder that is detectable in a bodily fluid. Examples include diagnostic applications such as diagnosing diseases such as Malaria, Chagas, Giardiasis, Microfilariasis, Sickle-cell disease, and other diseases. Stains for common parasites and diseases can be used  
10 with the samples. The sample and stain can be observed with the optical microscope to determine the presence or absence of the diagnostic target. The optical microscopes can also be used for general purposes, including science education.

[000104] In some embodiments the lens is a substantially spherical lens, for example a ball lens. A ball lens advantageous for manufacturing because it can minimize part count and be  
15 assembled without concern for rotational alignment as shown in FIG. 8A. Ball lenses can be formed from molten glass or UV-curable epoxies. Suspension polymerization can also be used to produce spherical GRIN lenses with reduced spherical aberration. Other examples of ball lens materials include borosilicate, sapphire, BK-7, polymeric materials such as acrylic, etc.

[000105] The ball lens can be sized based on the desired magnification of the optical  
20 microscope. As shown in FIG. 9A the magnification varies inversely with the ball lens radius. For a high magnification, e.g. above 500X, the ball lens can have a small radius, such as below 0.5 mm. The small lens size allows for a thinner optical microscope thickness and smaller form factor. In some embodiments the ball lens has a diameter of less than about 2,500 microns. In some embodiments the spherical ball lens has a diameter of about 1,000  $\mu\text{m}$  to about 2,500  $\mu\text{m}$ .  
25 In some embodiments the ball lens has a diameter of less than about 1,000 microns. In some embodiments the spherical ball lens has a diameter of about 300  $\mu\text{m}$  to about 1,000  $\mu\text{m}$ . In some embodiments the ball lens has a diameter of about 100 microns to about 1,000 microns. In some embodiments the ball lens has a diameter of about 100 microns to about 3,000 microns. In some embodiments the spherical ball lens has a diameter of about 100  $\mu\text{m}$  to about 300  $\mu\text{m}$ .

30 [000106] In some embodiments half-ball spherical lenses can be used. In some embodiments a Wallston doublet lens is utilized. The Wallston doublet lens can be composed of multiple half ball lenses. In some embodiments a Gradient Index lens is used.

[000107] In some embodiments the effective aperture of the substantially spherical lens in the optical microscope can be less than the full diameter of the spherical lens. For example, a  
35 portion of the spherical lens can be covered or removed to reduce the effective aperture of the

spherical lens as discussed in detail below. In some embodiments the aperture is about 1/4 to about 2/3 of the diameter of the spherical lens. In some embodiments the spherical ball lens has an aperture diameter of about 1/4 to about 1/3 of the spherical lens diameter. In some  
5      embodiments the spherical lens has an aperture diameter of about 1/3 to about 1/2 of the spherical lens diameter. In some embodiments the spherical lens has an aperture diameter of about 1/2 to about 2/3 of the spherical lens diameter.

**[000108]** The components of the optical microscopes can be selected to achieve a desired magnification and resolution as discussed in detail below. In some embodiments the optical microscope has a magnification of about 100X to about 200X. In some embodiments the optical  
10     microscope has a magnification of greater than about 140X. In some embodiments the optical microscope has a magnification of about 200X to about 500X. In some embodiments the optical microscope has a magnification of greater than about 300X. In some embodiments the optical microscope has a magnification of greater than about 500X. In some embodiments the optical microscope has a magnification of about 500X to 1,500X. In some embodiments the optical  
15     microscope has a magnification of greater than about 1000X. In some embodiments the optical microscope has a magnification of greater than about 1500X. In some embodiments the optical microscope has a magnification of about 1,500X to 2,500X. In some embodiments the optical microscope has a magnification of greater than about 2000X. In some embodiments the optical microscope has a magnification of greater than about 2500X.

**[000109]** In some embodiments the microscope has a resolution of about 2.0 to about 3.0 microns. In some embodiments the microscope has a resolution of about 1.5 to about 2.0 microns. In some embodiments the microscope has a resolution of about 1.0 to about 1.5 microns. In some embodiments the microscope has a resolution of about 0.88 to about 1.0 microns. In some embodiments the microscope has a resolution of about 0.6 to about 0.88  
25     microns. In some embodiments the microscope has a resolution of less than about 1.0 microns. In some embodiments the microscope has a resolution of 0.2 to 0.5 microns.

**[000110]** Examples of light sources include sun light, LED lights, a lamp, indoor lighting, incandescent lighting, fluorescent lighting, a flame, chemiluminescence source such as a glow stick, and other light sources.

**[000111]** In some embodiments the light source is an LED light. In some embodiments the LED is white. A white LED can provide a full-spectrum color image of the sample in bright-field. In some embodiments the LED is blue. A blue LED can provide light of an appropriate wavelength for fluorescence imaging. In some embodiments the LEDs have power suitable so that a user may perceive multiple simultaneous images of the sample. In some embodiments the  
35     LED has a luminous emittance of about 1-100kLux or more, which is suitable to project an

image of the sample. In some embodiments the LED has a power of about 10-1,000 Lux, which is suitable to illuminate the sample so that a user's eye may perceive the image of the sample.

[000112] In some embodiments the light source can be coupled to an illumination stage. In

some embodiments the optical device or microscope includes an illumination stage with an

5 element for modifying the profile of the light from the light source (e.g. LED), such as a

condenser, diffuser, light shaping diffuser, polycarbonate light shaping filter, etc. The

illumination stage can also include a condenser to focus the light from the light source. Filters

can also be used with the illumination stage. Examples of filters include polarization filters,

polymer color filters, diffusive filters, and fluorescence filters. In some embodiments, optical

10 microscope has an illumination stage that provides Kohler illumination.

[000113] In some embodiments the illumination stage includes an aperture or hole for allowing

light to pass through the illumination stage towards the sample. The illumination stage aperture

can be sized based on the size and diameter of the lens. In some embodiments the aperture has a

diameter of about 1/4 to about 2/3 of the diameter of the lens

15 [000114] A power source, such as a battery, can be used to provide power to the light source.

The power source can be coupled to the illumination stage.

[000115] The sample can be provided to the optical microscope on a substrate. The substrate

can include a coating or reagent. In some embodiments the substrate can be provided on the flat

material having the optic stage, sample stage, and illumination stage. In some embodiments the

20 sample is provided on a glass slide.

[000116] FIG. 1 illustrates the components for assembly into an exemplary optical microscope.

The optical microscope 100 includes sample or specimen stage 110, an illumination stage 112, a

spacer insert 114, a locking spacer insert 116, and an optics stage 118. In various embodiments,

the optical microscope 100 may not include an illumination stage 112. In the embodiment

25 without an illumination stage 112, the illumination source may be an external source, such as the

sun, a lamp, a candle or some other source. Components 110-118 may be part of a single flat

sheet of paper that may be used to implement the optical microscope. The specimen stage 110

may include microscope identifiers 120, grid 122, horizontal position indicators 124, vertical

position indicators 125, specimen illumination window 126, vertical fine position indicator 128,

30 horizontal fine position indicator 130, slide sleeve 132 and slide viewing window 134. In the

illustrated embodiment, horizontal position indicators 124 are denoted by the letters A-L and

vertical position indicators 125 are denoted by the letters U-Z. Each letter A-L and U-Z of the

horizontal position indicators 124 and vertical position indicators 125, respectively, may advance

in increments of 2mm. Any increment may be implemented. The microscope identifiers 120

may give the specification information that may include the microscope modality and magnification.

5 [000117] Grid 122 may be used along with horizontal position indicators 124, vertical position indicators 125, vertical fine position indicator 128, and horizontal fine position indicator 130. Specimen illumination window 126 may be an aperture or hole that allows a user to view a sample. Slide sleeve 132 may be folded over specimen illumination window 126 of specimen stage 110. Slide sleeve 132 may include slide slot 136 and slide tab 131. Slide tab 131 may be inserted into tab slot 121 during assembly. The size of each of the slide sleeve 132, slide slot 136, slide tab 131, slide slot 136, slide guides 139 and tab slot 121 may control the force that holds the slide in place. In various embodiments, the size of each of the slide sleeve 132, slide slot 136, slide tab 131, slide slot 136, slide guides 139 and tab slot 121 is configured to allow the slide to be easily inserted and positioned. In various embodiments, the size of each of the slide sleeve 132, slide slot 136, slide tab 131, slide slot 136, slide guides 139 and tab slot 121 is configured to maintain an original position and resist movement after the sample slide is inserted. A slide containing a sample may be inserted through slide slot 136 into slide sleeve 132. Slide guides 139 along the edges of slide sleeve 132 may be folded over to help guide insertion of the slide. The sample slide (not shown) may be positioned over specimen illumination window 126. The edge of the sample slide is lined up so that it is adjacent to a longitudinal edge 138.

20 [000118] Specimen stage 110 includes a mechanism for reproducing microscope settings. The mechanism is implemented by grid 122, vertical fine position indicator 128, horizontal fine position indicator 130, horizontal position indicator 124, vertical position indicator 125 and slide sleeve 132.

25 [000119] The illumination stage 112 may include circuitry 140, light source 142, and contact pads 144A-B. Circuitry 140 may include copper tape, conductive paper, conductive ink, or any other flat conductive material. The circuitry 140 can control the power supply to light source 142. In various embodiments, the power supply includes a battery. Light source 142 may include one or more LED lights, a lamp, a chemiluminescence source such as a glow stick, or other source. Illumination can be enhanced via a condenser lens 157 (located between 156 and 30 158). Contact pads 144A-B may establish contact with contacts on the optics stage 118. Illumination stage 112 may be mounted to specimen stage 110. In various embodiments, the optics stage 118 and the illumination stage 112 remain aligned within 0.5mm or better during panning and focusing. This may be accomplished by connecting tabs 145A-B in the illumination stage 112 into the slots 147A-B in the optics stage 118.

[000120] A light source using chemiluminescence uses a chemical reaction as the illumination or light source. Liquid light sources may flow into a tube or flat chamber and allow for a wide array of optical designs. The liquid light source may move translationally so that the user sees the entire sample. Usually, one only has 2 degrees of freedom; the present disclosure  
5 allows vision of everything on the slide. Additionally, the present disclosure may allow for a configuration of a tube within a tube. A liquid light source within inner tube may illuminate a sample located between the inner tube and the outer tube. This design requires “zero power” to remove the need for a power source such as a battery or button cells.

[000121] Spacer insert 114 and locking spacer insert 116 may be used to position the lens  
10 (not shown) and adjust the optics of the optical microscope 100. One or more spacer inserts 114, 116 may be attached to illumination stage 112. One or more spacer inserts 114 may be positioned first. The locking spacer insert 116 is positioned over the one or more spacer inserts 114 to lock or hold them in position.

[000122] Optics stage 118 may include contacts 146A-B, vertical slits 148, horizontal slits  
15 150, and lens apertures 152. Optics stage 118 is mounted to illumination stage 112 and specimen stage 110. Contacts 146A-B are designed to align with contact pads 144A-B. By depressing contacts 146A or 146B, a circuit is closed with light source 142 and a power source causing light source 142 to illuminate.

[000123] Vertical slits 148 and horizontal slits 150 align with vertical fine position  
20 indicator 128 and horizontal fine position indicator 130, respectively. As the sample slide is moved to the left horizontally, the horizontal fine position indicators 130 advance in that direction as it goes from one line to the next. In various embodiments, each horizontal line of horizontal fine position indicator 130 may represent a specific increment such as 0.5mm. If a user sees two solid lines at the same time, the position is in between increments such as 0.25mm.  
25 Any increment may be implemented. A location may be determined by the horizontal position indicators 124 and the vertical position indicators 125. For example, as a user looks at the left side of the optical microscope 100, a mark (not shown) indicates the horizontal position is at A or B. The vertical position may be determined similarly using vertical position indicators 125, X, Y, and Z, and may have similar increments. Vertical fine position indicator 128 and  
30 horizontal fine position indicator 130 may compliment vertical position indicators 125 and horizontal position indicator 124 by providing more detailed alignment information.

[000124] The optical microscope 100 may be created using a flat manufacturing process. Components may be together on a flat sheet that can be cut out and folded into an optical device. A design of pre-cut sheets can be created, downloaded, printed and used. Several integrated  
35 microscopes can be contained in one such optical microscope, creating different optical

microscopes based on how the paper/material is folded. The present microscope may be a single-use microscope and is suitable for the present technology because the overall manufacturing process is inexpensive enough to discard or incinerate after use.

[000125] FIG. 2A illustrates a top view of an exemplary optical microscope. FIG. 2B illustrates a cross-sectional view of the optical microscope of FIG. 2A. The optical microscope 100 of FIGs. 2A-B include specimen stage 110, illumination stage 112, optics stage 118, and sample 154. Sample 154 may be viewed through slide viewing window 134 (See FIG. 1). Light source 156 may direct light through filter 158, condenser 157, sample 154, specimen illumination window 126 and is received by lens 160. Lens 160 may be positioned between spacer inserts 114 and locking spacer insert 116. In some embodiments, a second lens may be implemented between sample 154 and light source 156. In some embodiments an array of lenses are used. In some embodiments a condenser is used to shape the light and improve resolution.

[000126] Focusing the optical microscope 100 can be shown with reference to FIG. 2B. Focusing the lens 160 can be implemented by a flexure mechanism that uses a cantilever beam of paper being pinched at two points for a symmetric upward and downward motion of the embedded optics as shown in FIG. 2B. Tension or compression of the optics stage 118 causes a Z-axis scan via a flexure mechanism. The flexure mechanism can have a maximum travel distance of about 1mm. The flexure mechanism can convert purely translational pinching movement along the X-axis to upward or downward motion along the Z-axis. The distance between the lens 160 and the sample 154 can be adjusted by pushing or pulling on the ends of the optics stage 118. Pushing the ends of the optics stage towards each other causes the lens 160 to raise thereby increasing the distance between the lens 160 and the sample 154. Pulling the ends of the optics stage 118 away from each other lowers the lens 160 thereby decreasing the distance between the lens 160 and the sample 154. The movement of the lens 160 towards and away from the sample 154 can be referred to as movement along the z-axis. In the case when there are two lenses (as shown in FIG. 5C), the lenses may be a certain distance apart. In various embodiments, the lenses may be about 6mm apart. In other embodiments, the lenses may be about 5.5mm apart. If a user finds something in left lens and wants to look at the same article/item with the right lens, the user may put a mark on grid 122. A marking instrument such as a pen or pencil may be inserted through marking apertures 133 in the optics stage 118 and marking apertures 135 in the illumination stage 112 to mark a position on grid 122. The user then moves the optics stage 118 so that it is lined up with the mark on grid 122. This may also allow a second user to find and view the same article/item using markings created by the first user. For example, a lab technician may be able to easily locate a particular pathology that has

been indicated by markings on grid 122. The marking apertures can be used in any of the lens arrangements described herein. The marking apertures can have a precision of 0.5mm or less.

[000127] The optical design may include focusing features, zoom features, panning features, and/or other features. Lens 160 may have a magnification of 140x, 340x, 680x, and 1140x corresponding to a borosilicate ball lenses with diameters of 2.4mm, 1.0mm, 0.5mm, and 0.3mm, respectively, as well as other magnifications. A variety of materials may be used for the lens. The lens may have a short path length due to the flat optical design that reduces signal-to-noise ratio for fluorescence. The path length may be symmetric or asymmetric. An asymmetric path length is created with a filter, a specimen, another filter, a ball lens on the top side, a light source and a light receiver. If a ball lens is placed on the bottom, the microscope becomes symmetric. The second lens may correct for the LED's divergence, making the light rays parallel rather than diverging, optimizing the LED. The LED may also act as a point source depending on the design.

[000128] FIG. 3 illustrates different embodiments of optical microscopes with various magnifications and modalities. Bright field optical microscopes are shown with a magnification of 435X (1), 1450X (2), and 2175X (3). A fluorescence microscope with Acridine Orange and Auramine stains is depicted in 5. A polarization microscope is shown in 6. An optical microscope with a multi-array of lenses is shown in 7. A projection microscope is shown in 8. FIG. 4 illustrates an optical microscope in accordance with an embodiment assembled from a flat material.

[000129] FIG. 5A shows a schematic arrangement of the parts of an optical microscope on a flat material that can be cut, folded, assembled, and used to diagnose a blood sample. FIG. 5B illustrates various parts of an optical microscope prior to assembly in accordance with an embodiment. FIGS. 5C, 5D, and 5E illustrate assembling and adjusting portions of an optical microscope. FIG. 5C illustrates the x-y scanning feature. FIG. 5D illustrates two lenses 160 with magnifications of 140x and 330x, respectively. The 140x magnification lens 160 produces a bright field image. The 330x magnification lens 160 produces a fluorescence image. The glass slide 170 is shown engaged with the optical microscope 100. FIG. 5E illustrates the z-axis focus by pushing inward on the edges of the optical stage.

[000130] FIGS. 5F-G are various images produced by a conventional microscope (FIG. 5F) compared to images taken with an optical microscope in accordance with embodiments (FIG. 5G). The images in FIG. 5F were taken using a Nikon Eclipse fluorescence microscope with a Hg lamp, LED, and glow stick under a magnification of 400X, respectively. FIG. 5G illustrates fluorescence images produced by an optical microscope in accordance with embodiments disclosed herein for AO stained beads and AO stained white blood cells at a magnification of

330X and 140X, respectively. The images illustrated in FIG. 5F are comparable to the images achieved using a conventional microscope shown in FIG. 5G.

[000131] The optical devices disclosed herein can be assembled without written language instructions. This is advantageous because the optical microscopes can be used in a variety of countries without requiring translations of the instructions for different countries. The language free folding instructions can include colors and pictures to facilitate the assembly of the optical microscope. The language free instructions can be directly printed on the instrument itself, for example a color matching scheme that guides a user to correct folding sequence. The surfaces of the optical microscope can also provide staining instructions for the sample. The surfaces of the optical microscope can include an identification guide for the diagnostics provided on the optical microscope. FIGS. 6A and 6B illustrate examples of optical microscopes prior to folding in accordance with various embodiments. FIGS. 6A and 6B are illustrated in black and white but can include bright colors to facilitate the folding and assembling instructions.

[000132] The optical microscopes can be folded and assembled with a high degree of precision and accuracy. Traditional optical instruments require significant alignment post assembly. An advantageous feature of a folding optical assembly design is that self-alignment can be exploited with kinematic constraints present in how the folds are executed, even for manual folding. Folding a sheet of paper introduces an alignment error proportional to the thickness of the paper in a valley or mountain fold. This error arises from uncertain position of a hinge in a fold due to buckling of paper in the inner edge of the fold. The alignment errors can be corrected by introducing folding features that provide kinematic constraints, for example mating the two stages and implementing closed structural loops during folding. For a mechanical process, repeatability is inversely proportional to the square root of contact points for elastically averaged coupling alignment schemes. The optical microscopes disclosed herein, for example, can utilize four contact points and two alignment surfaces to couple the optics and illumination stage. To characterize the alignment accuracy and repeatability of the optical microscopes, twenty independent microscopes were cut out of A4 sheets of paper with a laser cutting tool having a cutting error of  $\pm 6$  microns. Each microscope was hand folded and unfolded repeatedly, while measuring X-Y alignment errors between the optical and illumination stage. FIGS. 7A and 7B illustrate data for the accuracy and repeatability, respectively, for folding and unfolding the optical microscopes. Assembly accuracy and precision for the optical alignment as small as 10 microns was demonstrated for the microscope components in a manual assembly process using paper with a thickness of about 150  $\mu\text{m}$ . The optical alignment can include the alignment of the light source, optic/lens, sample stage, and any other items within this path, such as filters,

diffusers, apertures, etc. The alignment precision was acceptable for the lens sizes disclosed herein, for example a lens having a diameter of 300  $\mu\text{m}$ .

5 [000133] The optical microscopes disclosed herein can be durable and resistant to outdoor elements. For example, the optical microscopes can be stepped on and still work as shown in FIGS. 25A-B. The microscopes can work submerged in water and survive a fall from a three story building.

10 [000134] The optical device can be optimized based on the desired application or for general use. A number of parameters can be adjusted to optimize the optical device. For example, the lens size and shape, lens refractive index, lens material, the optical path length, optical path shape/direction, the lens aperture size and shape, the light source type and location, the aperture associated with the light source, the light source intensity and profile, the alignment of the light source with the lens, the wavelength of the light source, the polarization and coherence of the light source, the magnification of the sample, the resolution of the image, the inclusion of additional features such as automated staining or sample separation, the inclusion of a cell counter feature for keeping track of the level of parasitimia, optical filters placed in front of the light source or in front of the lens, etc.

15 [000135] In some embodiments, the folding accuracy is accomplished by geometrical features cut in flat material that act as kinematic couplings thus providing a self-alignment. In some embodiments, self-alignment is further improved by providing structural closed loops in folding steps.

20 [000136] In some embodiments, the optical microscope can have an integrated microfluidic channel for bringing samples directly to the microscope lens.

[000137] In some embodiments, the optical microscope can be incinerated after one use safely and thus can be used with infected samples. In some embodiments, the entire microscope is disposable after single or multiple uses.

25 [000138] In some embodiment, a waveguide is utilized to channel light from the light source to other optical components.

[000139] In some embodiments, the sample is reacted to a reagent already deposited in the sample holding stage via a microfluidic network embedded in the sample holding stage. In some embodiments, the reagent is dried for preservation. In some embodiments, the reagent is wet.

30 [000140] The devices disclosed herein can be modified to modify the optical path to a desired configuration. The flexibility in designing the optical path allows the device to be used as a general purpose optical design tool. Optical devices such as microscopes, interferometers, and spectrophotometers can be assembled using the methods, devices, and concepts disclosed herein.

[000141] In some embodiments, the lens can be cleaned by inserting a slide with lens paper attached to the surface followed by panning the second stage with the lens/optic in circles over the lens paper so that the lens paper brushes off contaminants from the surface of the lens.

[000142] FIG. 8A illustrates an exemplary optical path of an optical microscope in accordance with an embodiment. FIG. 8A illustrates the distance between the light source (e.g. LED) and sample object as  $D_{led-obj}$ , the distance between the sample object and lens as  $D_{obj-lens}$ , the distance between the lens and image plane as  $D_{lens-img}$ . The optical chain of the optical microscope includes illumination sources (distance  $D_{led-obj}$ ), condenser lens, illumination aperture ( $A_1$ ), sample glass slide, spherical micro-lens (radius  $r$ , refractive index  $n$  at a distance  $D_{obj-lens}$  from the slide) and entrance ( $A_2$ ) and exit ( $A_3$ ) aperture. For a real image in projection mode, the image plane is a distance  $D_{lens-img}$  apart. The total optical path length from the light source to the last lens surface can be about 2.5mm, which is only about 1% of the optical path length for a conventional microscope. The decreased optical path length allows for the microscope to be constructed with a short vertical height assuming a vertical optical path. The reduced optical path length can also minimize the extent to which stray light can enter the system and degrade optical performance.

[000143] FIG. 9A illustrates the magnification obtained versus various lens radii for different refractive index values. FIG. 9A depicts overall magnification obtained as a function of ball radius ( $r$ ) for refractive index ( $n$ ) values ranging from 1.33 to 2. The parameters shown in FIG. 9A can be optimized to improve the resolution of the optical microscope. Utilizing ray-tracing methods, a collimated beam of light entering an aperture diameter  $A_2$  and a spherical ball lens with a diameter ( $D=2r$ ) and refractive index  $n$ , is focused to a point given by the effective focal length  $EFL = \frac{nr}{2(n-1)}$  and numerical aperture (NA) is given by  $NA = \frac{A_2(n-1)}{nr}$  with magnification inversely proportional to ball lens radius as shown in FIG. 9A. A magnification of ~2175X can be obtained with a sapphire glass lens of about 200  $\mu\text{m}$  in diameter as shown in FIG. 9A. FIG. 9B illustrates the third order spherical aberration versus ball lens radii. The transverse third order spherical aberration can be expressed as  $TSC = \frac{[n(n-3)+1]A_2^3}{2n^2r^2}$  which reduces as a function of ball lens radius as shown in FIG. 9B.

[000144] The aperture radius ( $A_2$ ) can be optimized to maximize contrast and resolution, for example by balancing spherical aberration in the image and transmitted illumination intensity for a fixed wavelength of light. Considering collimated incident light, resolution as a function of lens-image distance ( $D_{lens-img}$ ) and aperture radius ( $A_2$ ) can be calculated both numerically and analytically. Since the optimization depends on two independent parameters numerical optimization is achieved in two stages. The first stage optimizes the focus by varying  $D_{lens-img}$ ,

while the second stage optimizes the resolution by varying  $A_2$  with  $D_{\text{lens-img}}$  equal to its optimum value for each aperture radius. For the first optimization stage, the focusing metric is chosen to be the reciprocal of the Strehl Ratio ( $1/SR$ ). Minimizing this focusing metric effectively selects a value for  $D_{\text{lens-img}}$  corresponding to diffraction focus, or best focus. FIG. 10 illustrates focusing metric versus the distance between the lens and image for RMS spot size ( $RSS$ ), inverse Strehl ratio ( $1/SR$ ), and ratio of spot size to Strehl ratio ( $RSS/SR$ ).

[000145] The second optimization stage calculates optimal aperture diameter ( $A_2$ ) by minimizing a resolution metric, evaluated as the ratio of Airy Disk Radius and Strehl Ratio ( $ADR/SR$ ). Graphically, this metric gives a curve that subtends the Airy Disk Radius ( $ADR$ ) for small aperture radii and parallels RMS Spot Size for large aperture radii. Also, it provides good numerical convergence. Numerical modeling results in design curves as a function of lens radius  $r$ , refractive index  $n$ , and incident light wavelength  $\lambda$ . FIG. 11A illustrates the normalized optimal aperture radius versus magnification for various radii and refractive index values. FIG. 11B illustrates resolution versus magnification for various radii and refractive index values. FIGS. 12A-12B illustrate calculations for the optimal aperture radius and resolution, respectively, as a function of ball lens radius, refractive index, and incident light wavelength.

[000146] For the analytical model, the optimization proceeds by evaluating the diffraction limited resolution at best focus, where the normalized longitudinal aberration ( $\Lambda$ ) is equal to 1. Two different analytical models can be used to derive identical results, within a multiplicative constant. In the first analytical model, Airy Disk Radius is equated to RMS Spot Size ( $ADR=RSS$ ). The Airy Disk Radius is evaluated as  $ADR = 1.22 \cdot \lambda \cdot F$ , where  $F = EFL/2A_2$  is the focal ratio or  $F/\#$ . The RMS Spot Size is approximated as the RMS blur radius ( $r_{RMS}$ ), at best focus,  $RSS \cong 4F \cdot |S|/\sqrt{6}$ , where  $F$  is the focal ratio,  $S = s \cdot A_2^4$  is the peak aberration coefficient and  $s$  is the aberration coefficient. For a ball lens, the following expression was derived for the aberration coefficient:  $s = -(n-1) \cdot [n + (2-n) \cdot (2n-1)]/8r^3 n^3$ . Setting the expression for  $ADR$  equal to the expression for  $RSS$  and solving for  $A_2/r$ , the following expression is obtained for the

normalized optimal aperture radius:  $nOAR = k'_1 \cdot \left( \frac{\lambda \cdot n^3}{r \cdot (n-1) \cdot [n + (2-n) \cdot (2n-1)]} \right)^{1/4}$ , where

$k'_1 = (1.22 \cdot 2 \cdot \sqrt{6})^{1/4} \cong 1.5636$ . This can be substituted into the expression for  $ADR$  (or that for  $RSS$ )

to obtain the following expression for image resolution:  $RES = k'_2 \cdot \left( \frac{\lambda^3 \cdot r \cdot n \cdot [n + (2-n) \cdot (2n-1)]}{(n-1)^3} \right)^{1/4}$ ,

where  $k'_2 = (1.22^3/2\sqrt{6})^{1/4}/4 \cong 0.1951$ . The above expression for optimal aperture and corresponding resolution show good agreement with the numerical calculations illustrated in FIGS. 12A-B.

The second analytical model determines the diffraction-limited resolution by minimizing the

ratio of Airy Disk Radius (ADR) to Strehl Ratio (SR), i.e. by solving  $\partial/\partial a(ADR/SR)=0$ . For this model, the Strehl ratio can be expressed using the empirical approximation,

$SR = \exp\left[-(2\pi\omega_s/\lambda)^2\right]$ , where  $\omega_s$  is the RMS wavefront error at best focus. As mentioned earlier, this model produces the same results as the first model, except with the constants now being,

5  $k'_1 = (6\sqrt{10}/\pi)^{1/4} \cong 1.5677$  and  $k'_2 = (1.22/4) \cdot (\pi/6)^{1/4} \cdot (e/10)^{1/8} \cong 0.2205$ . For example, the numerical and analytical models predict an optimized image resolution of about 0.88 $\mu$ m for a 300 $\mu$ m diameter sapphire lens, which agrees well with experimental data (see FIG. 12B and FIG. 18). In some embodiments a resolution can be as high as 500 nm at magnifications greater than about 2000X.

10 **[000147]** The resolution of the optical microscope can be quantified by observing an object having a known size. For example, fluorescence resolution was determined between two adjacent microspheres using ImageJ's linear intensity profile tool. Microspheres were considered to be resolvable when the minimum intensity value between the two spheres was 84.4% of the maximum intensity of the normalized dataset as is in accordance to the Rayleigh Criterion. To make peaks of intensity distinguishable, a local polynomial regression model  
15 weighted across every 10 pixels was used to smooth the data. Using this analysis, the 1 $\mu$ m beads were barely resolvable. FIG. 18 illustrates an image of 1  $\mu$ m polystyrene beads using a 300  $\mu$ m ball lens and an aperture size of about 150  $\mu$ m. FIG. 19A illustrates a bright field image of 1 micron polystyrene beads. FIG. 19B illustrates a fluorescent image of 2 micron polystyrene beads. FIG. 19C illustrates a plot of intensity versus distance.

20 **[000148]** For brightfield resolution, the beads could clearly be resolved between one another as shown in FIG. 18. As there are several methods for measuring resolution in brightfield, we borrowed a technique used by Lorusso and Joy (2003) for quantifying resolution using the Fourier Transform of the bead-matrix image. FIG. 19D is an image of the polystyrene beads shown in FIG. 18 along with a 2D-Fourier transform showing the power spectrum of the  
25 threshold image and spatial frequency detail. A threshold was set for the original image such that noise was removed and the 2-dimensional fast-Fourier transform was then performed on the image. Upon taking the power spectrum of the Fourier transform, the extent of the spatial frequencies was found. The mean radius of this ellipsoidal extent was then used to calculate the smallest feature size, which is equal to the resolution, in the image using the following equation:  
30 Resolution = ROIW \* PixelSize / RFFT \* Image Scaling where ROIW is the average width of the sensor and RFFT is the average radius of the power spectrum in the Fourier domain. The pixel size is the size of the pixels on the CCD. The image scaling is a factor used in determining the scale of the image plane compared to the CCD plane. For this image, the ROIW was 4680 pixels, the RFFT was 318.25, the Pixel Size was 6.4 micrometers and the Scaling factor was 95

CCD pixels per object pixel. This resulted in a calculated resolution of 0.99 micrometers. In general, this is a conservative method of measuring resolution as the smallest features can be filtered out with the noise during the threshold step.

5 [000149] FIG. 13 is a graph of resolution versus aperture radius for various metrics. The optimal resolution metric was obtained using the ratio of Airy Disk to Strehl ratio. FIG. 14 is a graph of the filter transmission versus wavelength for various filter types. FIG. 14 compares an excitation filter, emission filter, and diffusive filter. Associated fluorescence image data using the above filter set as barrier (blue) and emission (red) filter is shown in FIGS. 18 and FIG. 23L. In some embodiments the filters can be provided with separate light sources. In some  
10 embodiments the filters can be integral with the sample stage. In some embodiments the filter can be included with the optic stage.

[000150] Malaria samples are often observed under an oil immersion lens due to ring artifacts that arise because of curved shape of a red blood cell. FIGS. 15A and 15B are images of malaria samples observed with a diffuser. FIG. 15A is an image obtained using an  
15 embodiment of the optical microscopes described herein and FIG. 15B is an image obtained using a conventional microscope. FIGS. 15A and 15B illustrate that good quality images can be obtained without the use of an oil immersion lens. Using a simple thin plastic film diffuser that cuts out directional illumination can remove artifacts due to cell inhomogeneity and enhance the image component due to light absorption. An example of the transmission spectra of the  
20 diffusive filter is shown in FIG. 14.

[000151] FIG. 16A illustrate three different LED light sources with and without a condenser. The three LED based light sources, labeled #516, #350 and #425, were imaged using fluorescein dissolved in water. As shown in FIG. 16A, the condenser further focuses the light. FIG. 16B illustrates the illumination intensity in a polar plot of LED light source #516.

25 [000152] Additional modeling is shown in FIGS. 17A-D. A 0.3 mm sapphire lens is modeled in FIGS. 17A-D. FIG. 17A is model of the ray tracing for a 0.3 mm spherical ball lens. FIG. 17B a model of the RMS spot size for off-axis rays of 0, 5, 10, 15, and 20 degrees. FIG. 17C is a model of an RMS spot radius field map. FIG. 17D is a model of a Strehl Ratio field map.

30 [000153] The microscope may also allow a user to view the same object at two different magnifications at the same time. This embodiment can provide two concentric magnification regions, where the inner region is at a higher magnification than the outer region. This may be achieved by placing a half ball lens above a smaller diameter ball lens in a doublet configuration, for example. The microscope may be utilized as a single purpose microscope, having optics that  
35 depend on the type of stain used, the light source and the filters used. The optics design allows

for illumination to track with the optics. A reflective mylar sheet may be implemented for providing a mirror surface, and may allow for simultaneous frontside/backside imaging as shown in FIG. 8B.

**[000154]** The present microscope may have a simultaneous multi-modal imaging feature.

5 Multi-modal may involve two or more images on the retina simultaneously by taking advantage of the psychophysics of the eye. The present microscope may have one or more lenses. Each of the one or more lenses may correspond to a different microscope modality. The microscope modalities may include brightfield, darkfield, fluorescence in many sets depending on the type of filter implemented (GFP, YFP, AO, Auramine-O, DAPI, or other filter) or any other filter, and  
10 polarization using polarization filters and any other optical microscopy. Each of the microscope modalities may be implemented at high and low magnifications. One or more of the microscope modalities may be implemented at the same time on optical microscope 100 in any arrangement. For example, the microscope may include darkfield imaging at a specific magnification and brightfield imaging at a second magnification. Hence, in the same field of view, the user may be  
15 looking at the same object 1000x magnified, and simultaneously looking at it 10x magnified. In various embodiments, the microscope modalities form an array.

**[000155]** In various embodiments, the ball lenses may be arranged in an 3x3, 4x4 or 5x5 matrix, where each lens provides identical images but with a slightly different experience - a continuous field may be presented. For example, if looking at red blood cells, even though each  
20 ball is only contributing one portion of that field, it appears to be like a continuous field. The images provided by the matrix merge as one and appear as a landscape rather than individual images. In various embodiments, if a user changes an illumination angle, and turns it bright or dark, the microscope may provide the user with 3D information about the sample by producing contrast over the sample based on variations in the sample's 3D profile. Because the  
25 illumination stage can move, a user can take the same object and achieve a 3D imaging effect.

**[000156]** Another feature of the optical microscope 100 is a projection mechanism. FIG. 20A illustrates a schematic for utilizing a refraction ball lens for projection microscopy with ray-tracing for half of a lens. FIG. 20B illustrates a projection illuminated through water containing fluorescein. The projection mechanism can project images onto a wall, screen, or other surface.

30 The mechanism is a brighter LED such as a high-intensity LED to make the projection more visible. Rather than looking directly into the optical microscope, a user may flip it over and point to a wall in the dark. Two or more people may be looking at the same image at the same time. For example, in a dark room, a high-intensity LED may allow a projection of an image from across the room, making a 1mm mosquito proboscis appear over 2 meters tall on the wall.  
35 The projection may be onto a camera, a wall, a retina, or other location, and the microscope can

be a digital image of the projection - the projection optics are the same. In various embodiments, there is also a CCD version that may be provided with one or more cameras integrated in the present system.

5 [000157] The projected mode allows for a number of people to simultaneously view the images. The effective magnification in projection mode is dependent on the distance between the lens and the projected image with the intensity inversely proportional to the distance between the lens and projected image. FIG. 21A is a projected image of a mosquito proboscis at an effective magnification of 1500X. FIG. 21B is a projected image of red blood cells at an effective magnification of 3000X.

10 [000158] FIG. 22B is a picture of a single ball lens optical microscope projecting an image on the retina of a user in accordance with an embodiment.

[000159] Optical components of the manufacturing process may include microfluidics, doublets, and other features. Microfluidics may be used to manufacture components. Doublets may be created from liquid and cured lenses and used in combination with a microscope. This may allow for lower costs and timing while increasing magnification. A unique slide position readout may provide a location grid of the sample and allow a user to know where they are on the slide. An integrated cell count mechanism may also be used with the present optical microscope.

20 [000160] Fluidic integration into microscope design may minimize sample handling. An auto-staining process within the microscope involves filters designed from plastic films. The auto-staining process may have the staining dye already integrated.

[000161] Several optical microscopes may be contained in a single package. The optical microscopes can be packaged individually similar to a band aid and revealed just before use. This packaging minimizes the risk of having fungus grow on microscope components in humid environments.

25 [000162] The optical microscopes disclosed herein can also be used under water. The microscope can include a water resistant coating such as a polymer coating. Operating under water allows for live imaging of microscopic swimming organisms under water. The underwater image can be projected on the side wall of the aquarium. The thermal gradients generated allow for water to flow past by the sample stage, thus bringing live swimming organisms to be imaged in projection mode through the microscope. FIG. 22A is a picture of a single ball lens optical microscope submerged under water in accordance with an embodiment.

30 [000163] The optical microscopes disclosed herein can be used for disease diagnostics. For example, temperature stable stains are widely available for labeling infectious disease samples including Giemsa and Acridine Orange that are usually used on a standard thin blood smear.

Various imaging parameters of optical microscopes disclosed herein, such as field of view, magnification, etc. can be optimized to match the imaging requirements for a disease of interest. The optical microscopes disclosed herein can be configured and built to match a specific disease of interest. In some embodiments disease specific optical microscopes are used instead of  
5 general-purpose optical microscopes. For example, various optical microscope configurations were setup and utilized to image freshly prepared diagnostics samples of various parasitic diseases, including *Plasmodium falciparum* (FIG. 23A), *Trypanosom cruzi* (FIG. 23B), *Girardia lamblia* (FIG. 23C), sickle cell disease (FIG. 23D), gram positive and gram negative bacteria (FIG. 23E), *Leishmania donovani* (FIG. 23F) and *Dirofilaria immitis* (FIG. 23G) imaged via  
10 various magnification settings. It is noted that the above data (maximum magnification 2500X) was obtained without the use of oil immersion technique or coverslips, which further complicates sample preparation and microscope maintenance in conventional diagnostics assays. This broad dataset reveals the versatility of utility of the optical microscopes disclosed herein in disease diagnostics.

15 **[000164]** FIG. 24A is an image produced by a single ball lens optical microscope in accordance with an embodiment of human chromosomes. FIG. 24B is an image produced by a single ball lens optical microscope in accordance with an embodiment of a DNA/RNA stain. FIG. 24C is an image produced by a single ball lens optical microscope in accordance with an embodiment of a spinal cord. FIG. 24D is an image produced by a single ball lens optical  
20 microscope in accordance with an embodiment of skeletal muscle.

**[000165]** Microscopy based diagnostics can be further improved via integrated multiple imaging modalities (such as bright field and fluorescence imaging) to improve sensitivity or increase the total field of view via implementation of parallel array microscopes. The optical microscopes disclosed herein can be packed in a close form to implement Simultaneous Multi-  
25 modal Microscopy (SMM) using the miniature optical components and independent optical paths disclosed herein. FIG. 23H is a schematic illustration of a 3x3 lens array with different modalities embedded in an optical microscope in accordance with an embodiment. The use of SMM is largely possible due to the large surface area of the retina (FIG. 23H) that allows for many fields of view to be packed in a closed packed configuration, such as 1+1, 2x2 or 3x3 array  
30 microscopes (FIG. 23I) with nine fields of view visible simultaneously (FIG. 23J). Since the optical path for each field of view is independent, different modes of microscopy can be combined to build simultaneous bright and polarization setup (FIG. 23K) or fluorescence from two different wavelengths (FIG. 23L). Simultaneous Multi-modal Microscopy (SMM) enables imaging of samples in multiple modalities simultaneously, which is not possible in conventional  
35 optical setups.

[000166] FIG. 8B is a schematic illustration of an optical path for an optical microscope in accordance with an embodiment. FIG. 8B illustrates two ball lenses 160. One ball lens 160 directly observes the sample 154 using the light source 142. The eye can directly observe the sample 154 through the optical path 201 and ball lens 160. Simultaneously, the eye can observe  
5 the sample through an alternate optical path 203 involving the second ball lens 160 and a mirror 205 that can be tilted to focus on the back of the sample. The mirror can be adjusted to observe a desired area of the sample 154. In some embodiments multiple lenses can be aligned with one or more mirrors to alternately view the sample.

[000167] The foregoing detailed description of the technology herein has been presented  
10 for purposes of illustration and description. It is not intended to be exhaustive or to limit the technology to the precise form disclosed. Many modifications and variations are possible in light of the above teaching. The described embodiments were chosen in order to best explain the principles of the technology and its practical application to thereby enable others skilled in the art to best utilize the technology in various embodiments and with various modifications as are  
15 suited to the particular use contemplated. The present invention descriptions are intended to cover such alternatives, modifications, and equivalents as may be included within the spirit and scope of the invention as defined by the appended claims and otherwise appreciated by one of ordinary skill in the art.

## CLAIMS

What is claimed is:

1. An optical device, comprising:  
5 a first stage for supporting a sample; and  
a second stage engaged with the first stage and movable relative to the first stage, the second stage including an optic, the optic having a distance of less than about 3 mm from the sample to the opposite side of the optic.
- 10 2. The optical device of claim 1, wherein the optical device is an optical microscope.
3. The optical device of claim 1, wherein the optical device is an interferometer or spectrophotometers.
- 15 4. The optical microscope of claim 2, wherein the second stage is movable laterally relative to the first stage such that the optic can be positioned over a desired location on the sample.
5. The optical microscope of claim 2, wherein the first stage is configured to receive a  
20 substrate containing the sample.
6. The optical microscope of claim 5, wherein the first stage includes a slot shaped to receive the substrate.
- 25 7. The optical microscope of claim 5, wherein the substrate is a glass slide.
8. The optical microscope of claim 7, wherein the glass slide includes a portion treated with a reagent to interact with the sample.
- 30 9. The optical microscope of claim 2, wherein the sample is supported directly on the first stage.
10. The optical microscope of claim 2, the first stage further comprising: a sample area  
35 comprising a reagent to react with the sample.

11. The optical microscope of claim 2, further comprising an illumination stage comprising a light source, the illumination stage engaged with the first stage and second stage, the illumination stage movable with the second stage, the light source positioned adjacent to the first stage to facilitate viewing the sample using the optic.
- 5
12. The optical microscope of claim 11, wherein when the light source is on one side of the first stage and the optic is spaced apart from the opposite side of the first stage a distance between the light source and the side of the optic farthest from the first stage is from about 1 mm to about 20 mm.
- 10
13. The optical microscope of claim 11, wherein the light source includes a light-emitting diode (LED).
14. The optical microscope of claim 13, wherein the LED has a luminous emittance of 1-15 100kLux or more suitable to project an image of the sample.
- 15
15. The optical microscope of claim 13, wherein the LED has a power of 10-1,000 Lux suitable to illuminate the sample so that a user's eye may perceive the image of the sample.
- 20
16. The optical microscope of claim 11, wherein the optic includes a substantially spherical lens having a diameter, wherein the illumination stage includes an aperture having a diameter of about 1/4 to about 2/3 of the diameter of the substantially spherical lens.
- 25
17. The optical microscope of claim 2, wherein the optical microscope is manufactured from a flat material that includes the first stage and second stage.
18. The optical microscope of claim 17, wherein a single material piece provides the first stage and second stage.
- 30
19. The optical microscope of claim 11, wherein the optical microscope is manufactured from a flat material that includes the first stage, second stage, and illumination stage, the optical microscope having an optical alignment of the illumination stage, first stage, and second stage achieved by separating and folding the flat material.
- 35
20. The optical microscope of claim 19, wherein the optical alignment has an accuracy of about 10 microns or less.

21. The optical microscope of claim 17, wherein the flat material comprises one or more of paper, polymer, and metal.
- 5 22. The optical microscope of claim 11, further comprising a power source engaged with the illumination stage and configured to provide power to the light source.
23. The optical microscope of claim 22, wherein the power source is connected to the light source.
- 10 24. The optical microscope of claim 2, wherein the optical microscope is a bright field microscope.
25. The optical microscope of claim 11, further comprising a light filter, wherein the optical microscope is a fluorescence microscope.
- 15 26. The optical microscope of claim 2, wherein the optic comprises a substantially spherical lens.
- 20 27. The optical microscope of claim 26, the second stage including an opening with the lens in the opening.
28. The optical microscope of claim 26, wherein the substantially spherical lens has a diameter of less than about 1,000  $\mu\text{m}$ .
- 25 29. The optical microscope of claim 26, wherein the spherical lens has a diameter of about 200  $\mu\text{m}$  to about 1,000  $\mu\text{m}$ .
30. The optical microscope of claim 26, wherein the microscope has a magnification of greater than about 300X.
- 30 31. The optical microscope of claim 26, wherein the microscope has a magnification of greater than about 1000X.
- 35 32. The optical microscope of claim 26, wherein the spherical lens has an aperture of about 1/4 to about 2/3 of a diameter of the spherical lens.

33. The optical microscope of claim 2, wherein the first stage for supporting the sample comprises a diagnostic coating for providing a visual indication to a user through the optical microscope of a presence of a diagnostic target.
- 5 34. The optical microscope of claim 33, wherein the visual indication is viewed using the optic.
35. The optical microscope of claim 33, wherein the diagnostic target is a disease, parasite, or bacteria, or disorder detectable in a bodily fluid.
- 10 36. The optical microscope of claim 2, wherein the optic includes an array of lenses.
37. The optical microscope of claim 36, wherein the array of lenses simultaneously shows one or more bright field images and one or more fluorescence images.
- 15 38. The optical microscope of claim 36, wherein the array of lenses includes four or more lenses.
39. The optical microscope of claim 11, the optical microscope having bright field and filter field viewing capabilities wherein a user shifts from bright field to filter field by lateral movement of the second stage and the light source that cooperate to provide either the bright field or the filter field.
- 20 40. The optical microscope of claim 2, further comprising a marking aperture on the second stage configured to allow a user to identify and indicate a target location on the sample by marking the first stage through the marking aperture on the second stage such that a second user can align the optical microscope to view the target location.
- 25 41. The optical microscope of claim 2, wherein the optical microscope has a resolution of about 1.0 micron or less.
- 30 42. The optical microscope of claim 2, wherein assembly of the optical microscope involves origami or folding of a flat sheet of material.
- 35 43. A method for using an optical microscope comprising:  
engaging a first portion of an optical microscope configured to support a sample with a second portion of an optical microscope having a lens;  
placing a sample on the first portion of the optical microscope;

adjusting the lens by moving the second portion of the optical microscope having the lens relative to the first portion of the optical microscope to focus on the sample; and viewing the sample.

- 5 44. The method of claim 43, wherein during the adjusting step the optical microscope has an optical path distance of less than about 3 mm from the sample to the opposite side of the optic.
- 10 45. The method of claim 43, wherein before the adjusting step or the viewing step is a step of placing a portion of the microscope against a user's eyebrow.
46. The method of claim 43, wherein viewing the sample comprises projecting an image of a portion of the sample.
- 15 47. The method of claim 43, wherein adjusting the lens includes moving the second portion relative to the first portion in an out-of-plane direction from a distance of about  $5\mu\text{m}$  to about  $625\mu\text{m}$ .
- 20 48. The method of claim 43, wherein viewing the sample comprises buckling the second portion to adjust the distance between the lens on the second portion and the sample.
49. The method of claim 43, further comprising before viewing interacting the sample with a reagent.
- 25 50. The method of claim 43, wherein viewing the sample comprises testing the sample for a disease.
51. The method of claim 43, further comprising before engaging removing the first portion and the second portion form a single piece of a flat material.
- 30 52. The method of claim 43, wherein engaging includes assembling the optical microscope from a flat material.

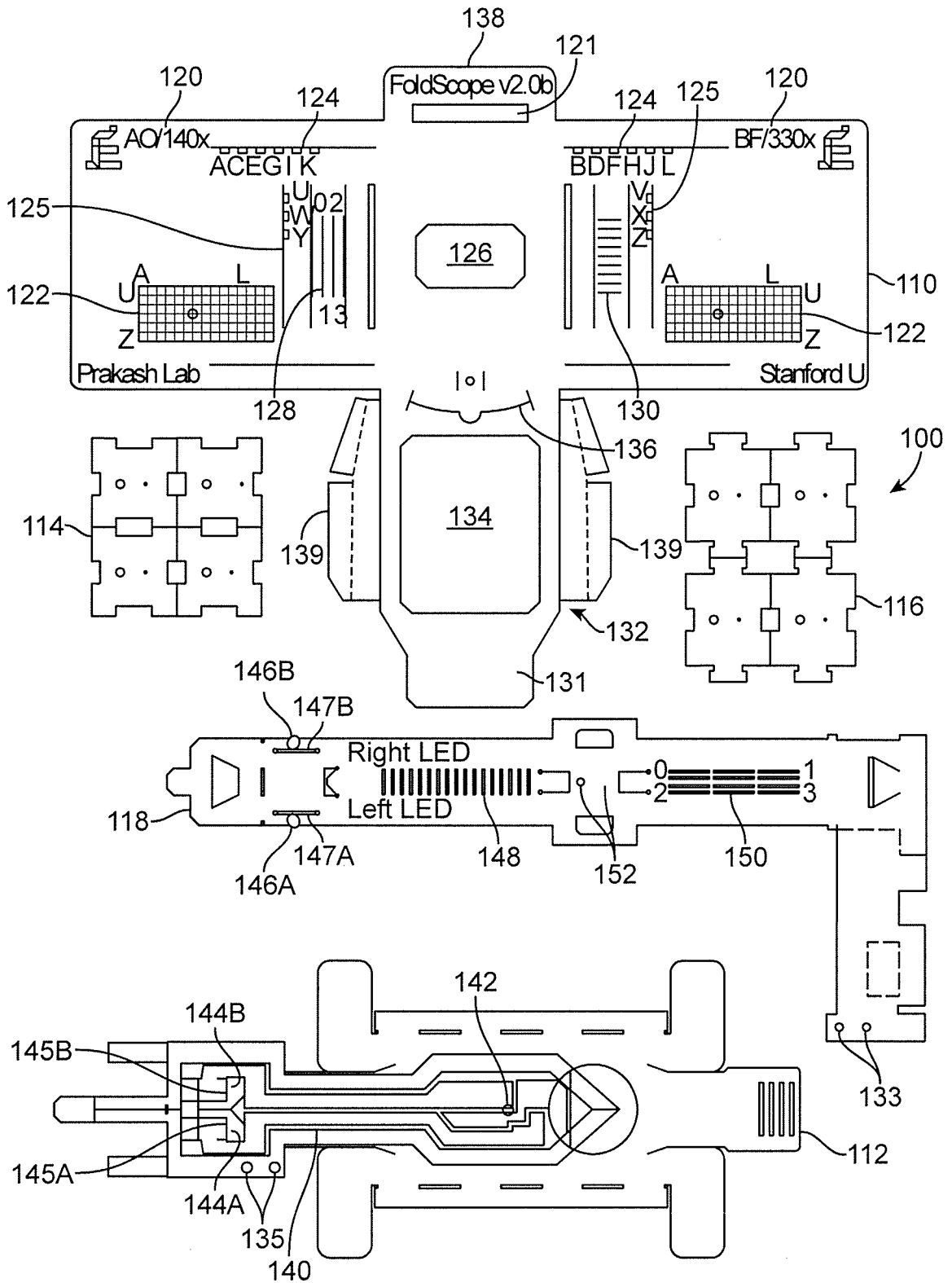

FIG. 1

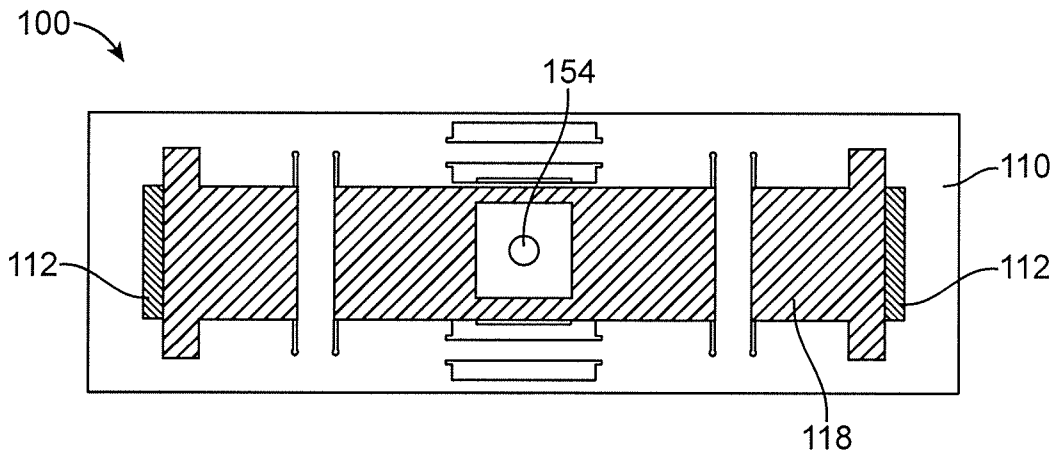

FIG. 2A

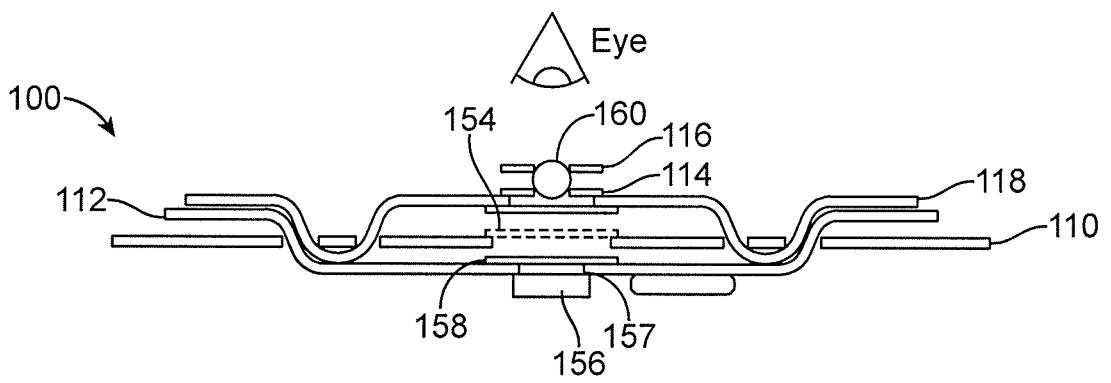

FIG. 2B

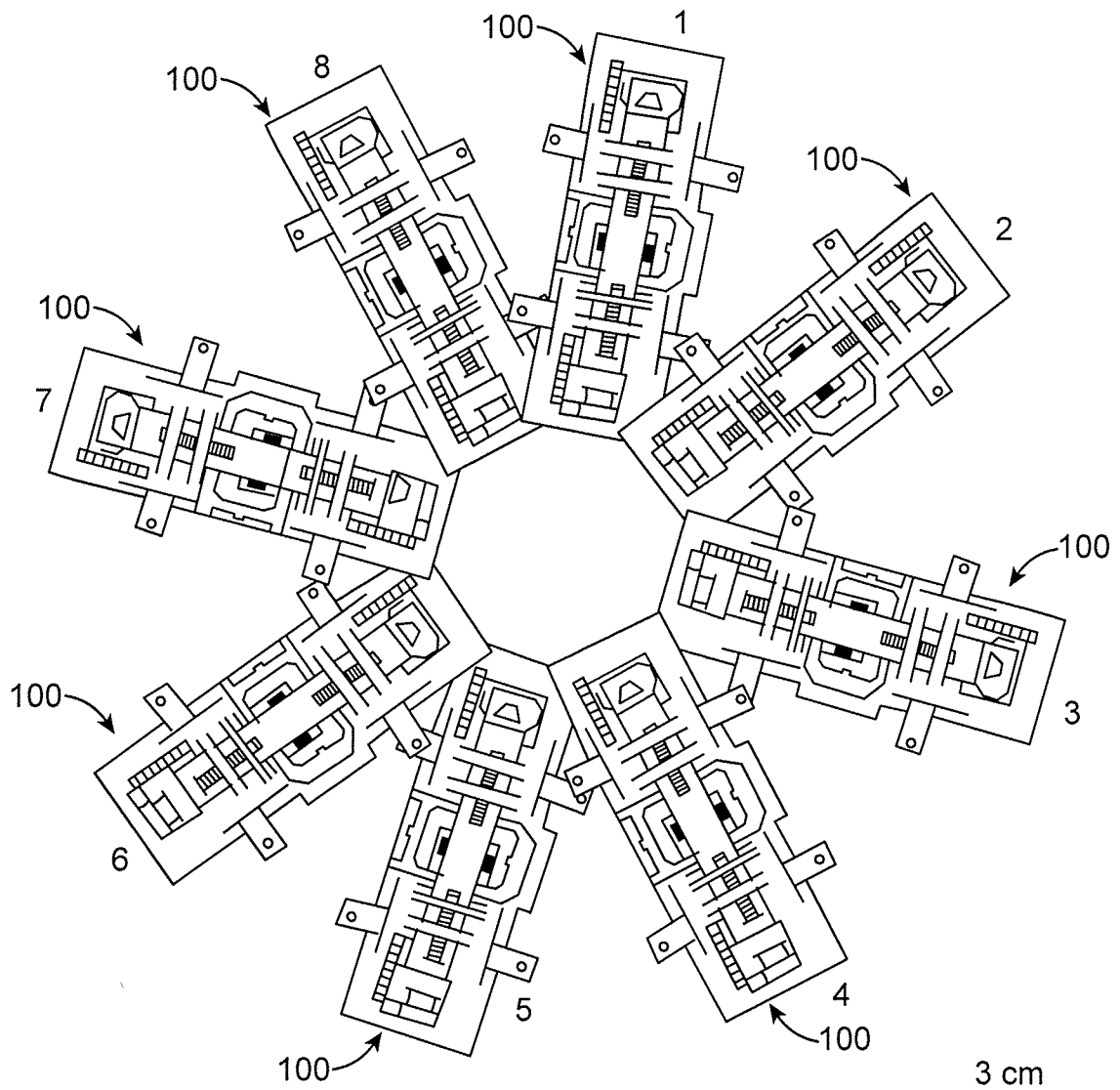

FIG. 3

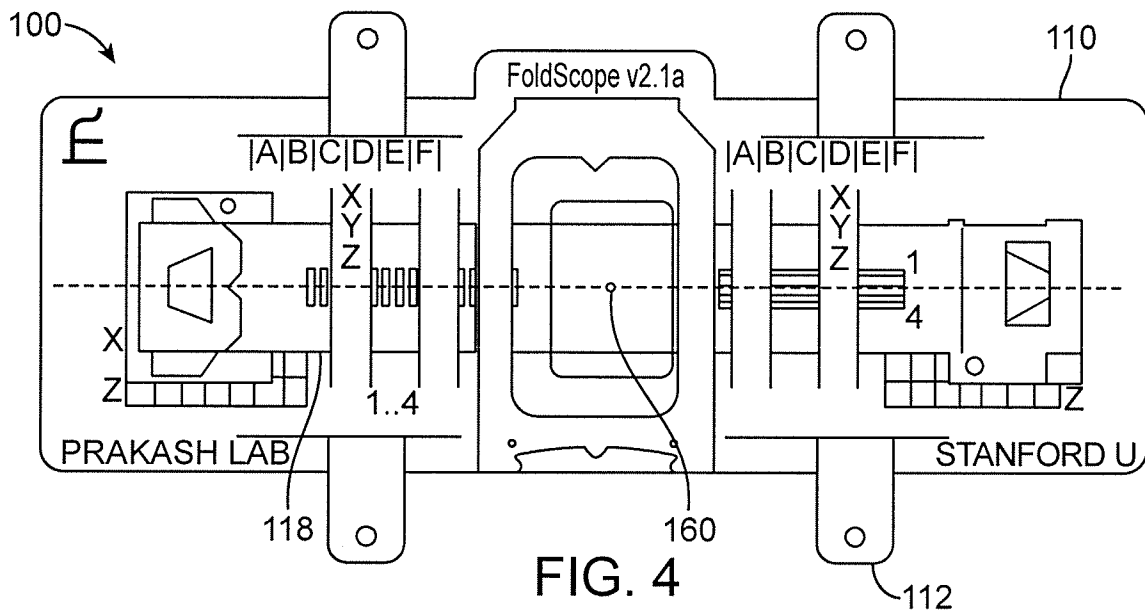

FIG. 4

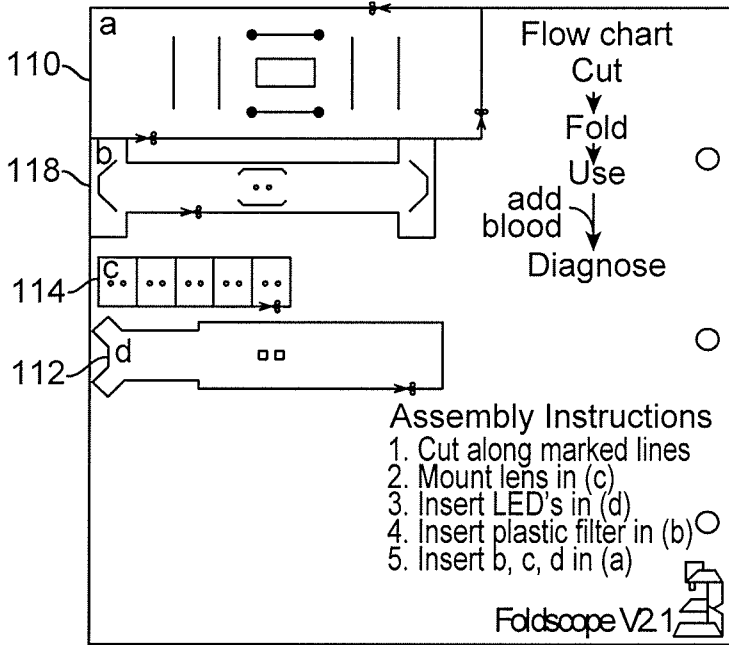

FIG. 5A

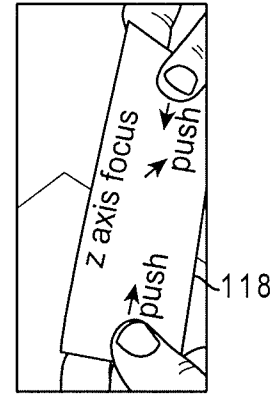

FIG. 5E

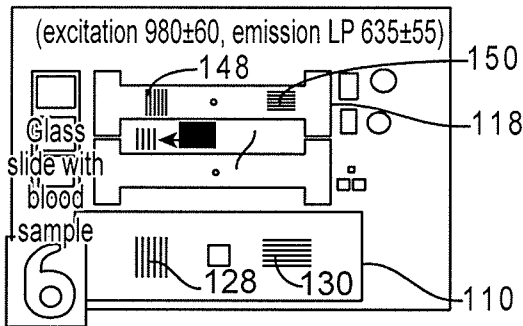

FIG. 5B

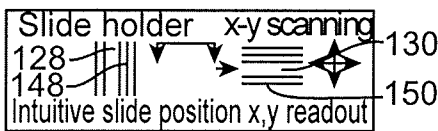

FIG. 5C

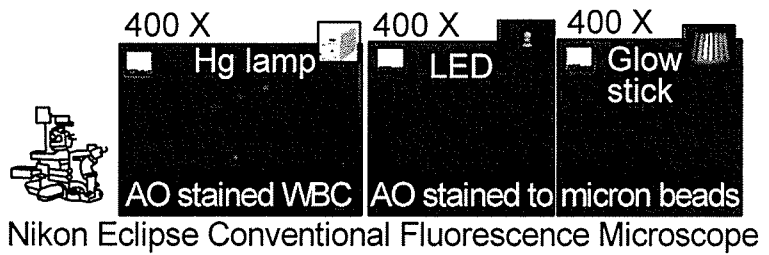

FIG. 5F

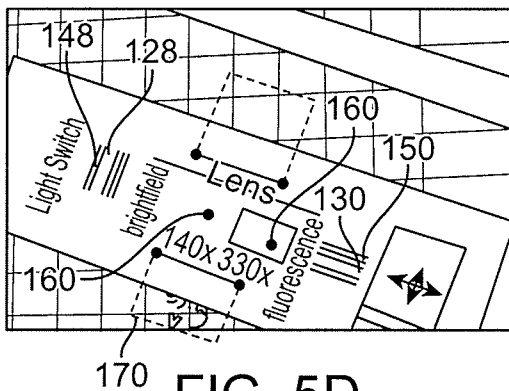
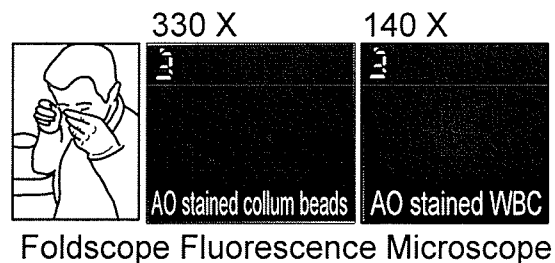

FIG. 5D



Foldscope Fluorescence Microscope

FIG. 5G

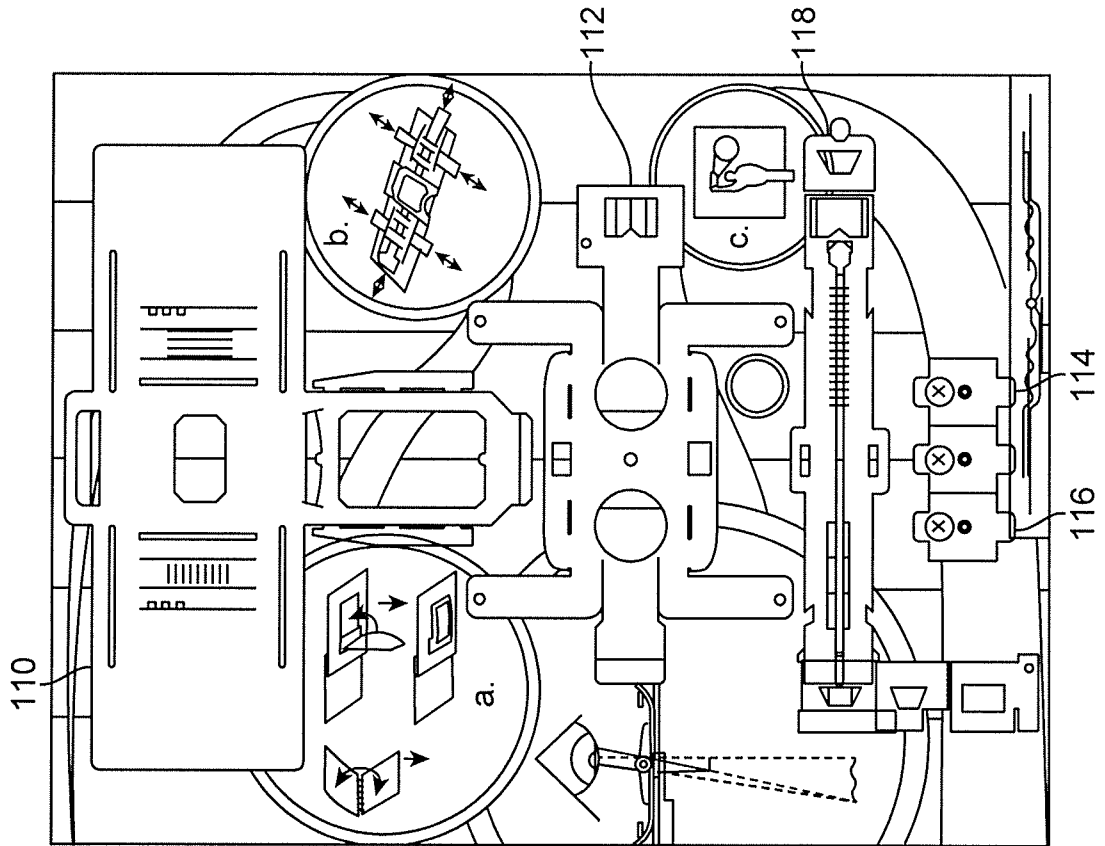

FIG. 6A

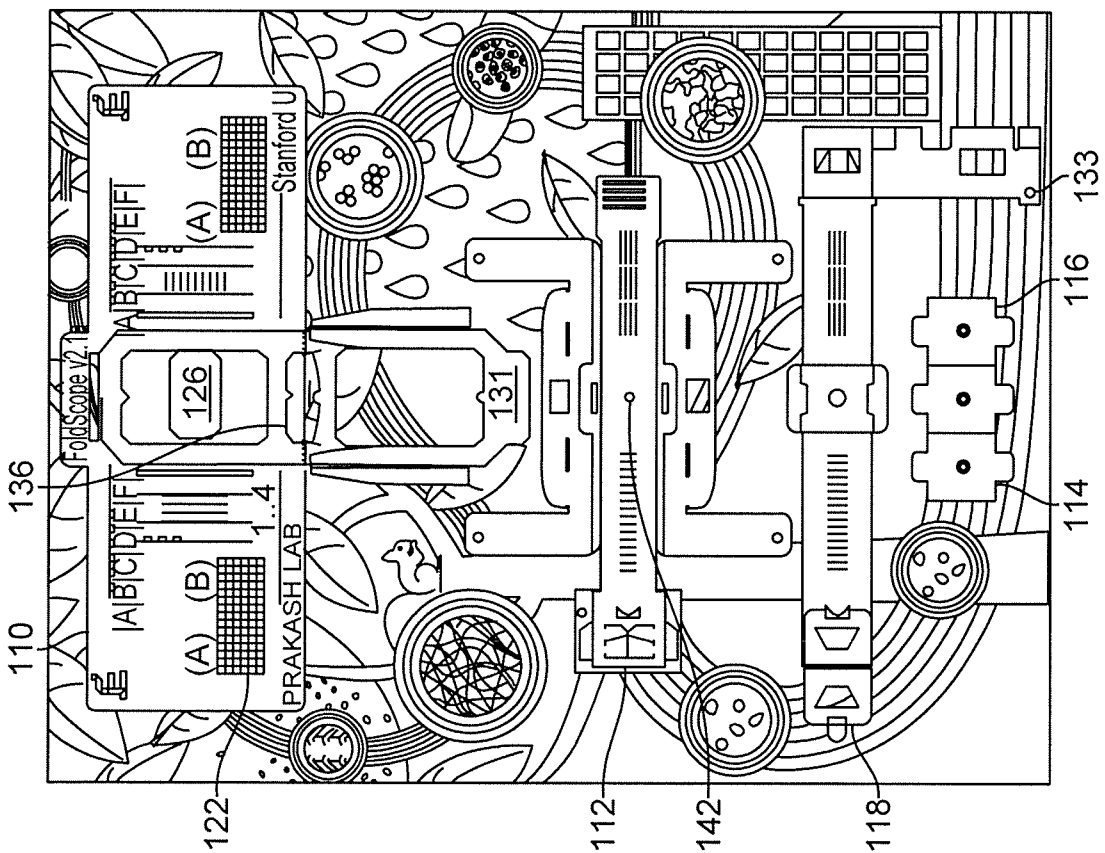

FIG. 6B

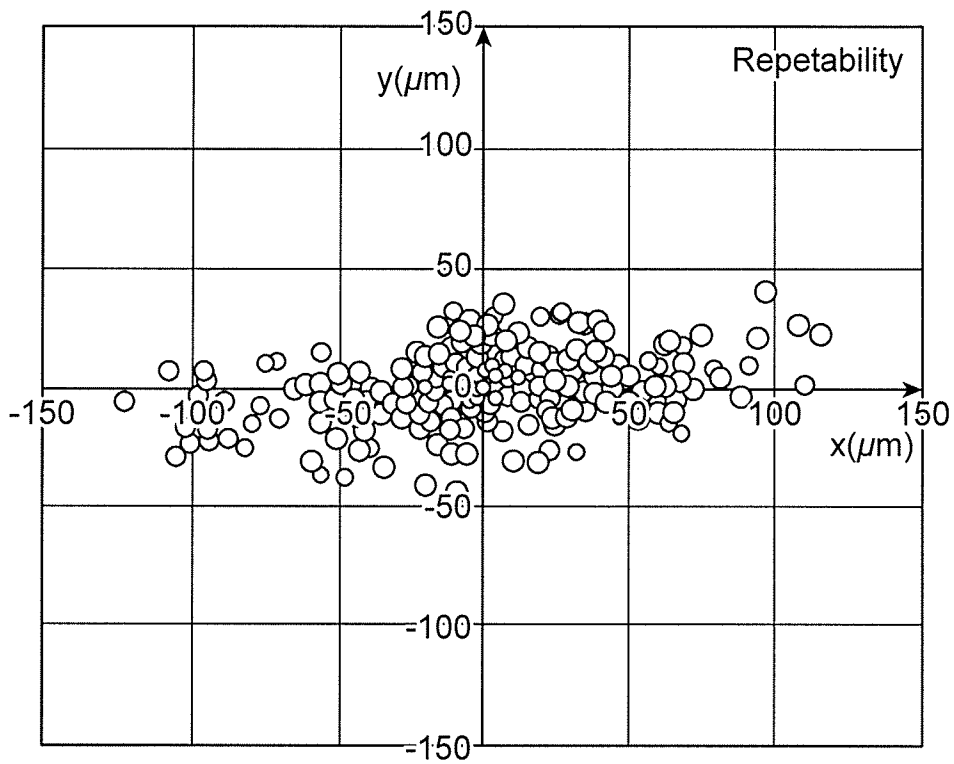

FIG. 7A

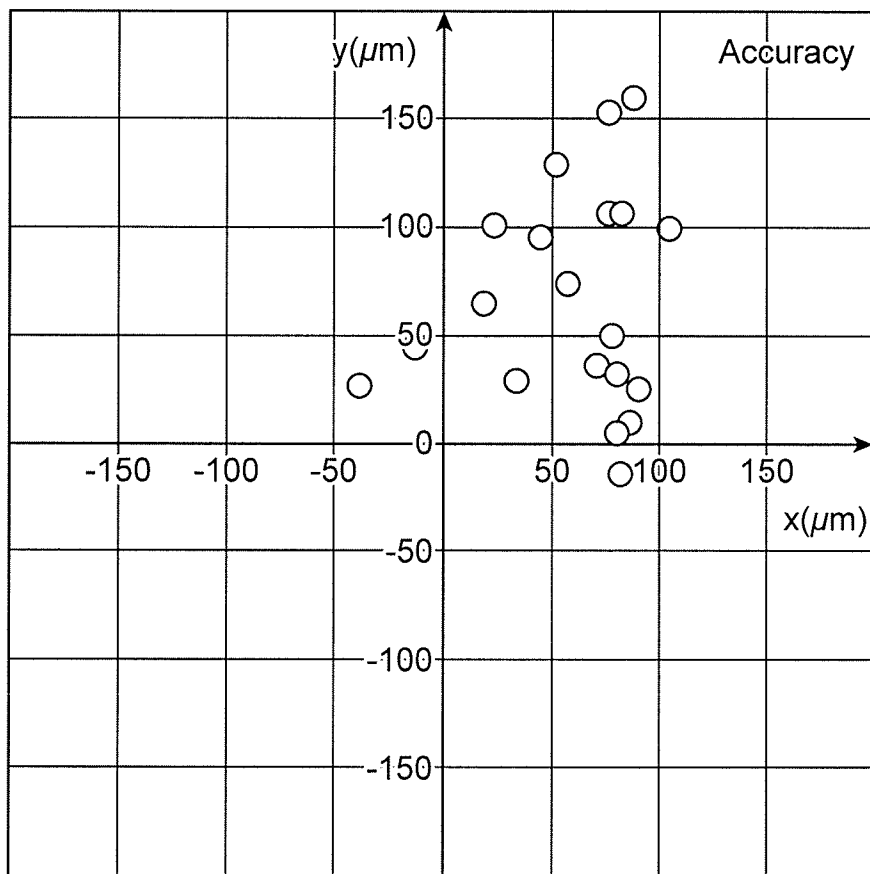

FIG. 7B

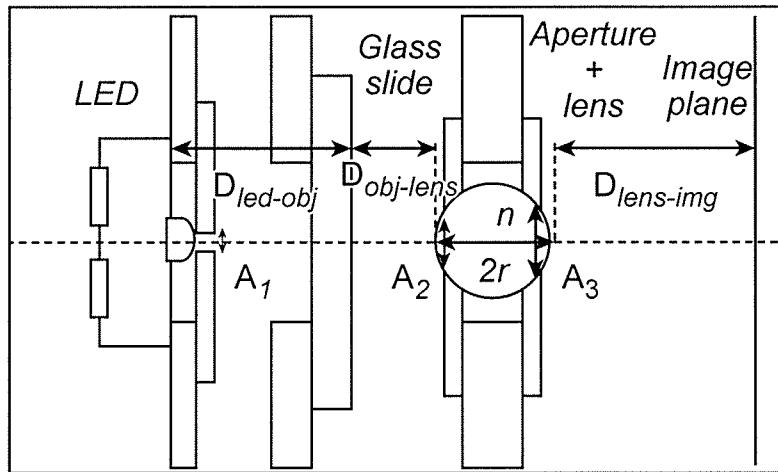

FIG. 8A

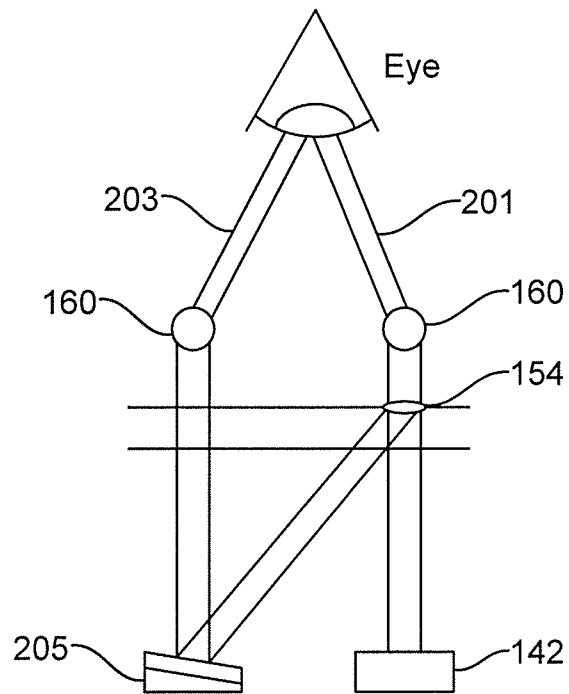

FIG. 8B

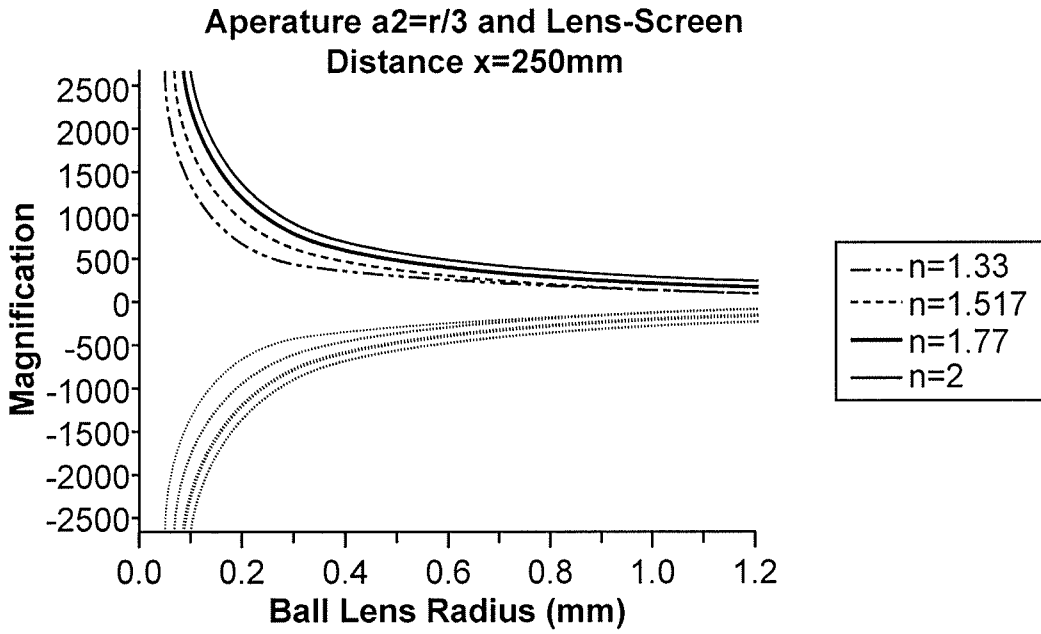

FIG. 9A

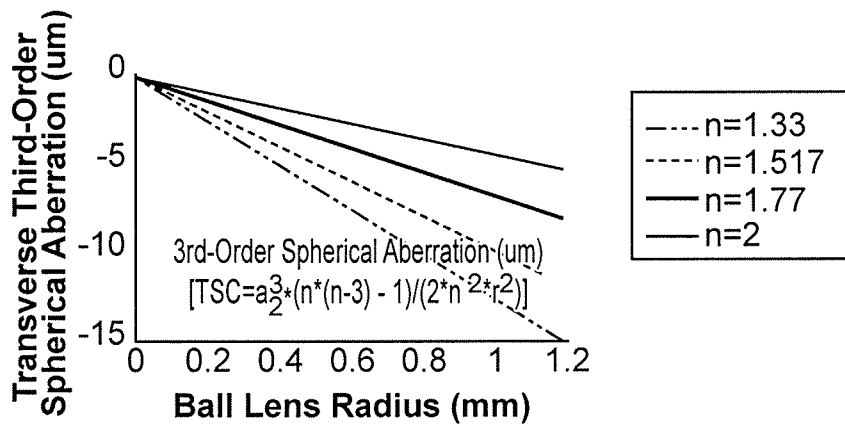

FIG. 9B

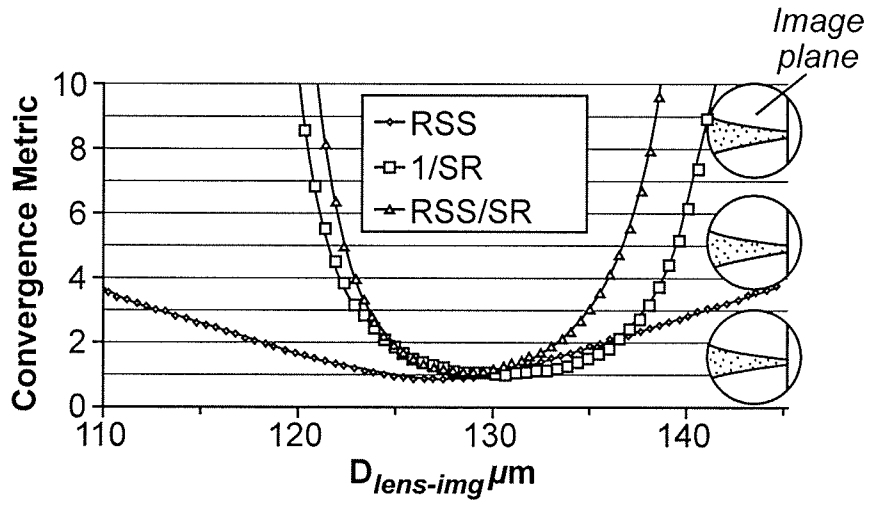

FIG. 10

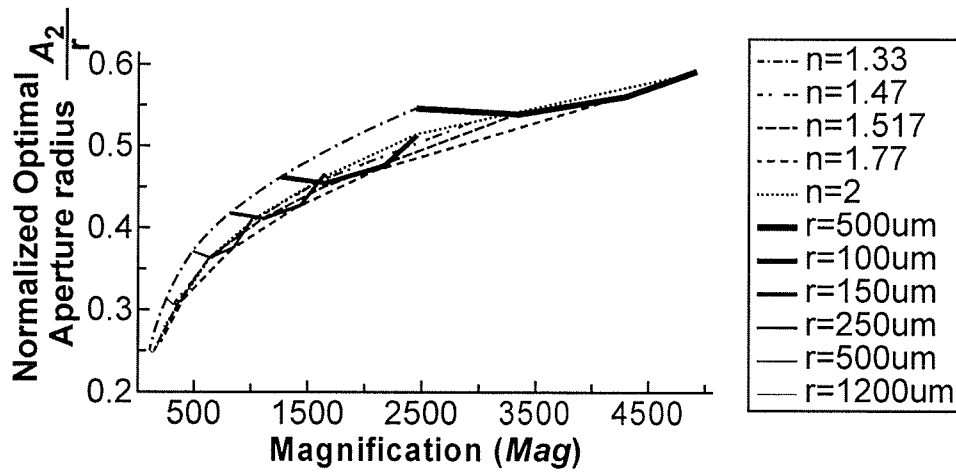

FIG. 11A

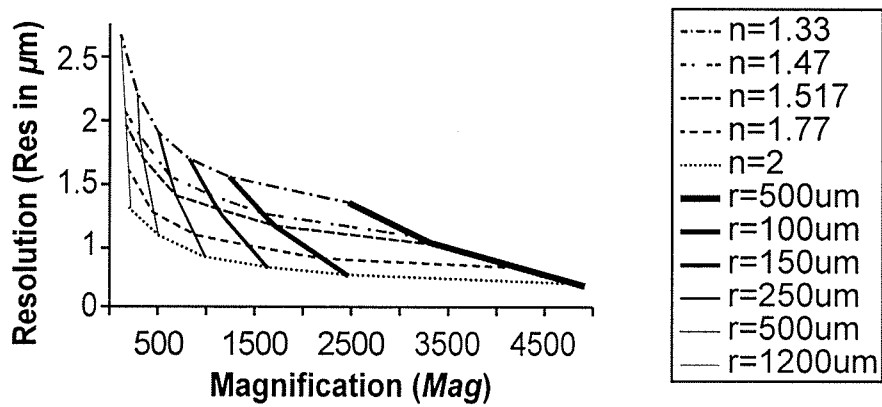

FIG. 11B

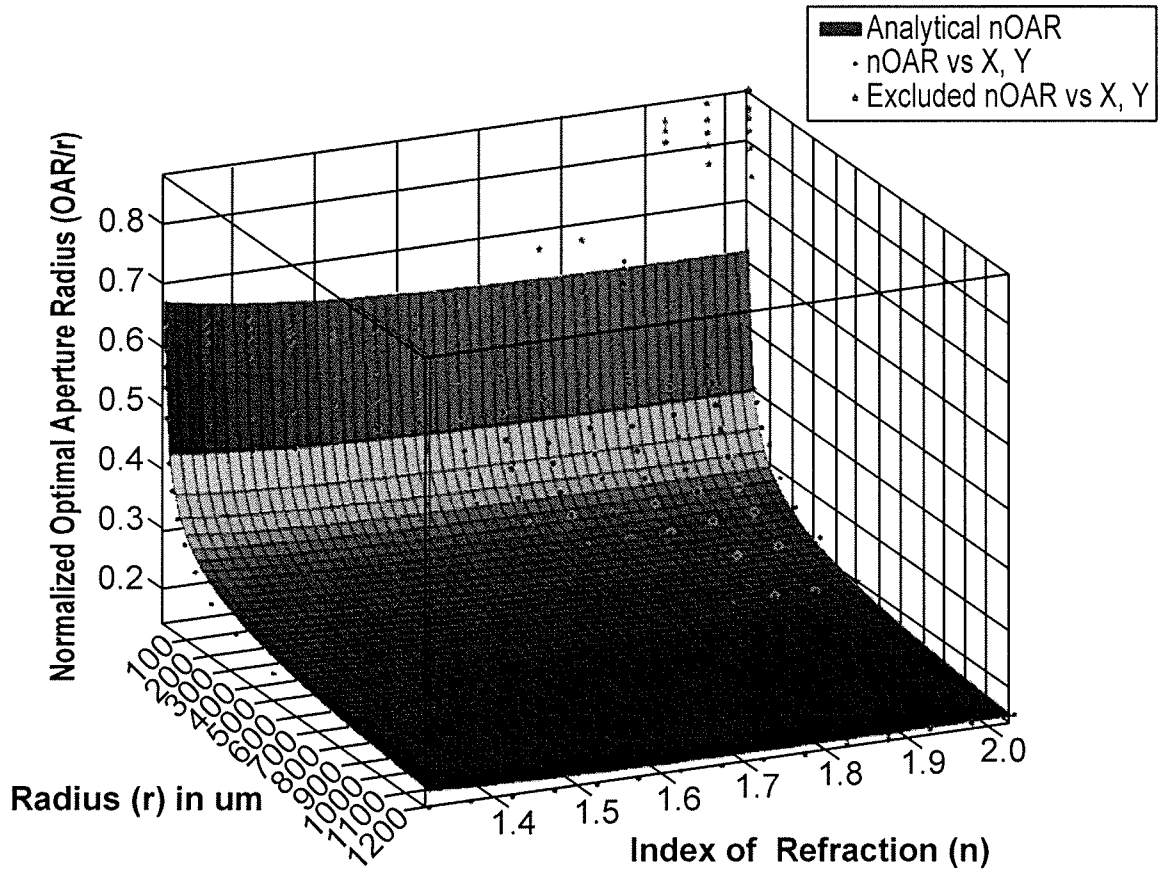

FIG. 12A

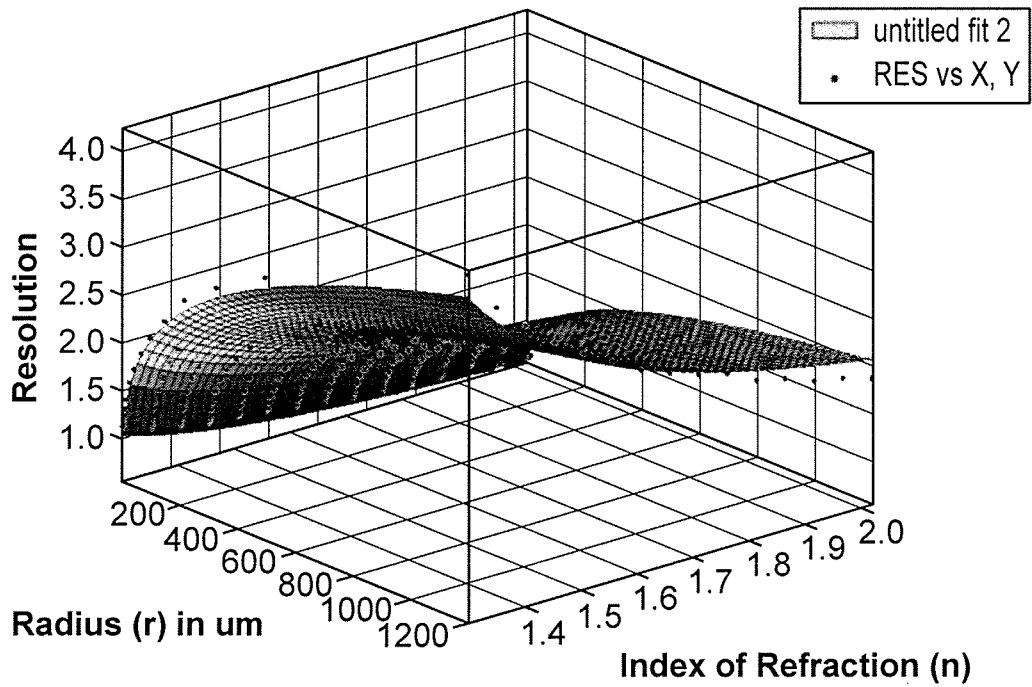

FIG. 12B

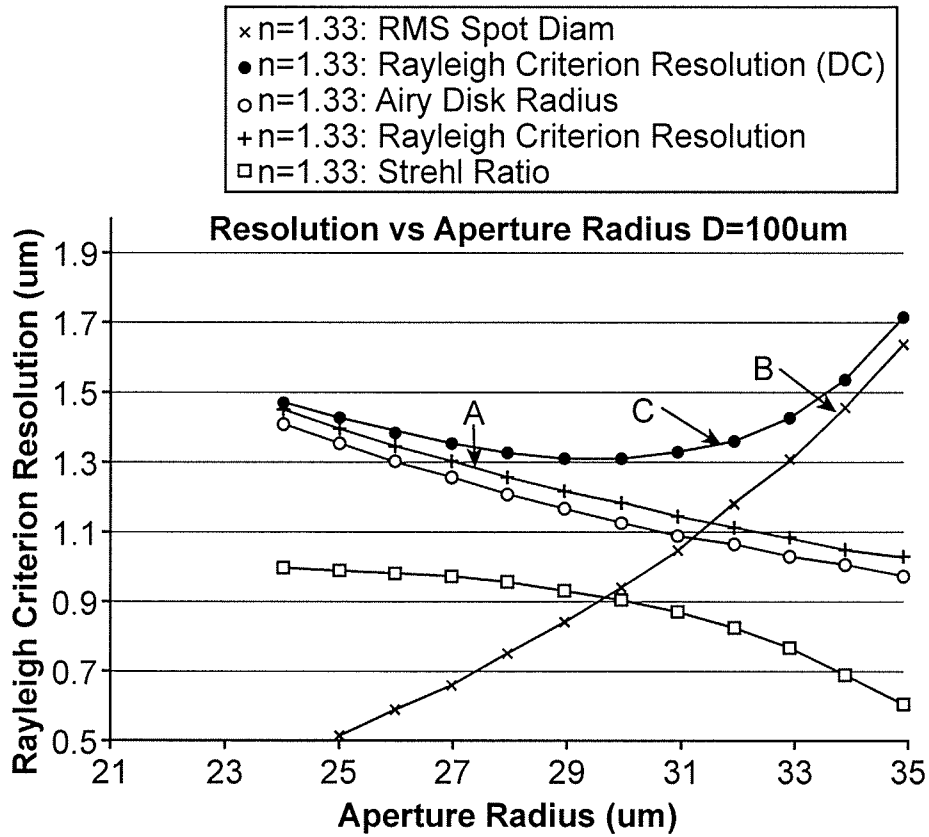

FIG. 13

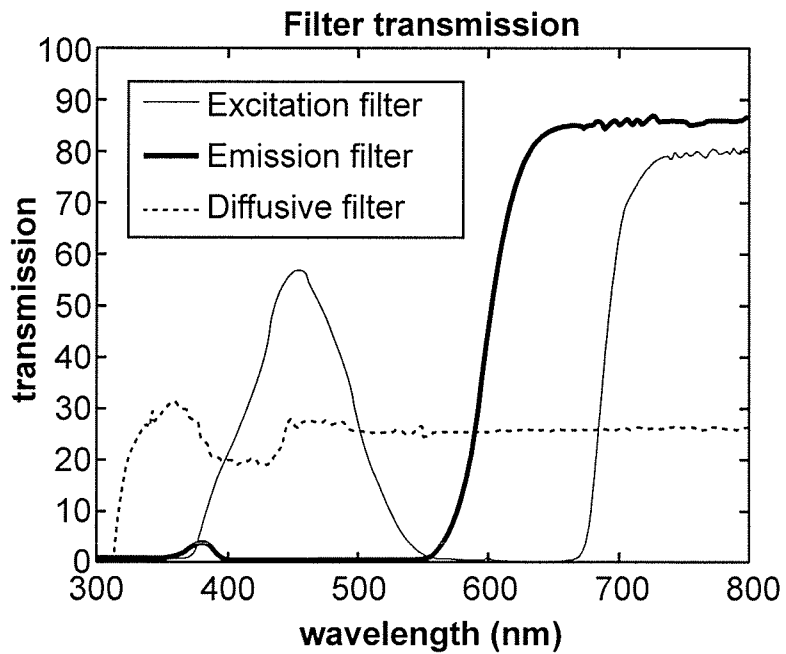

FIG. 14

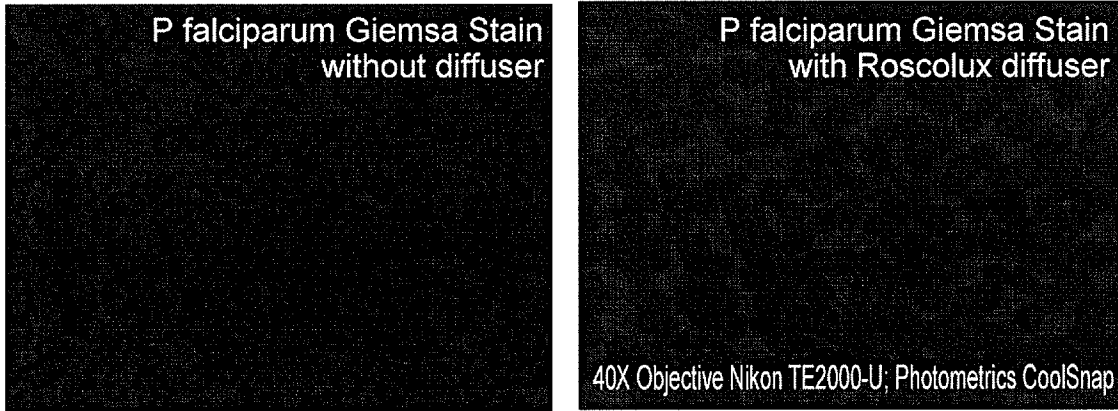

FIG. 15A

FIG. 15B

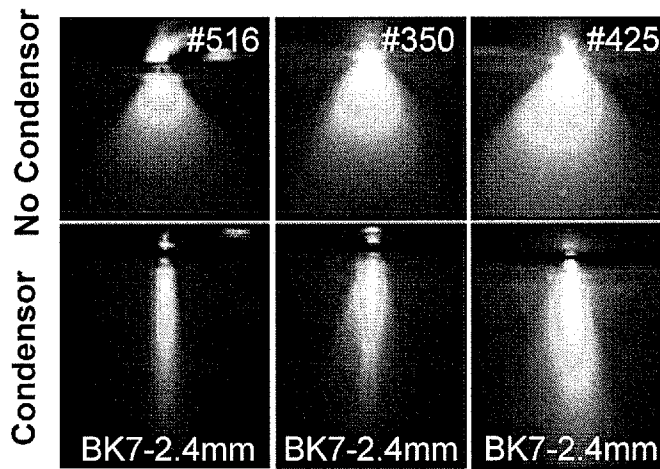

FIG. 16A

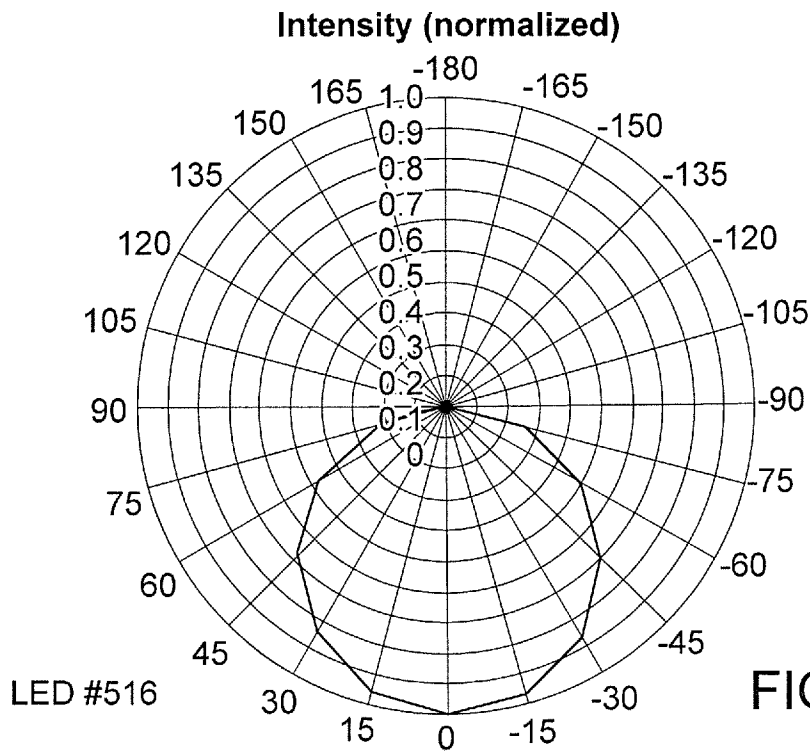

FIG. 16B

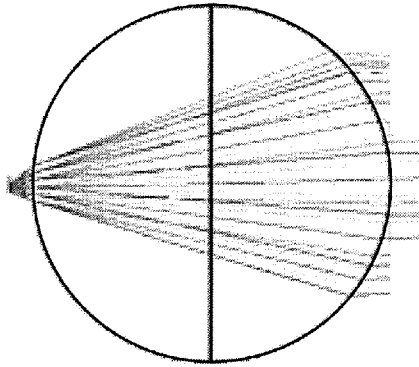

FIG. 17A

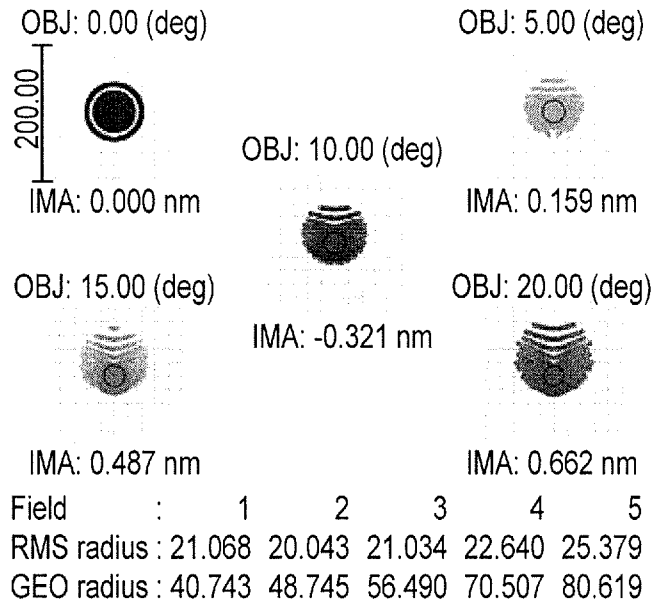
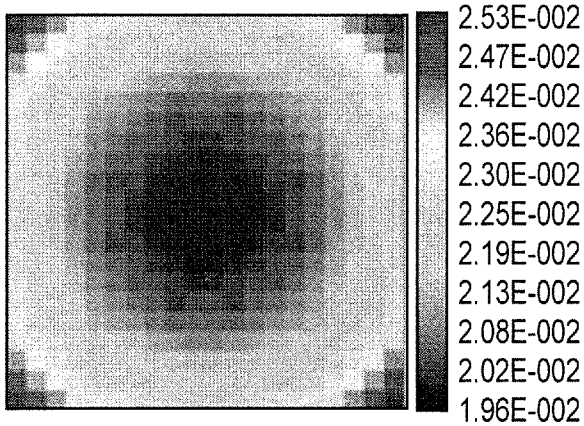
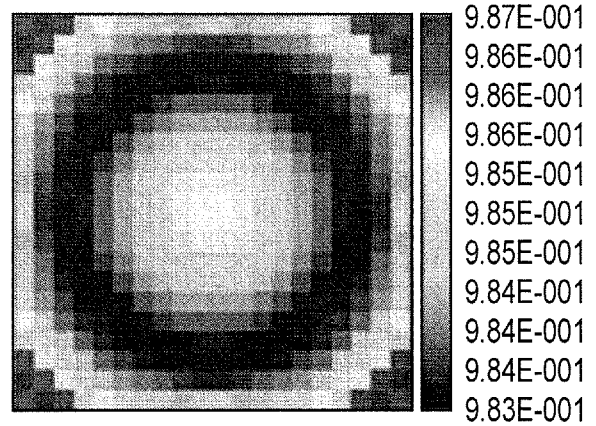

FIG. 17B



RMS Spot Radius Field Map

FIG. 17C



Strehl Ratio field Map

FIG. 17D

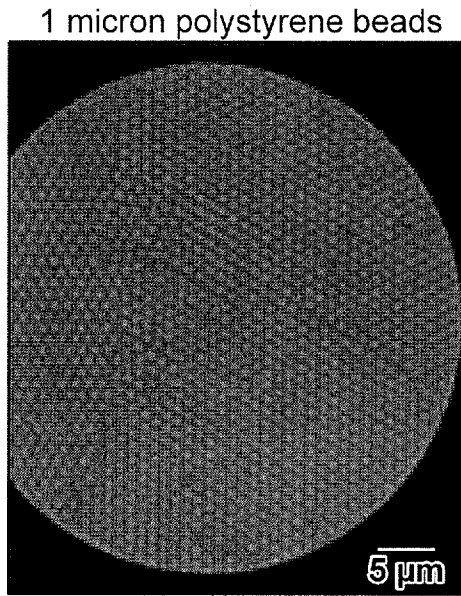

FIG. 18

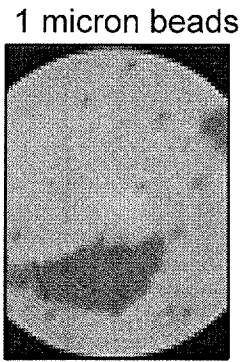

FIG. 19A

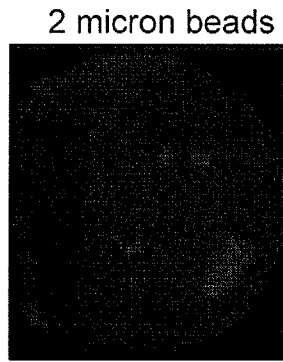

FIG. 19B

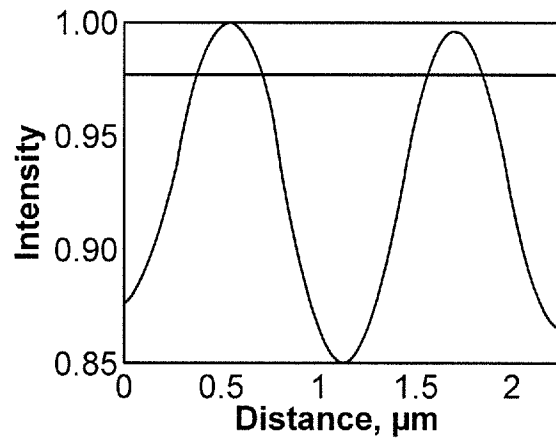

FIG. 19C

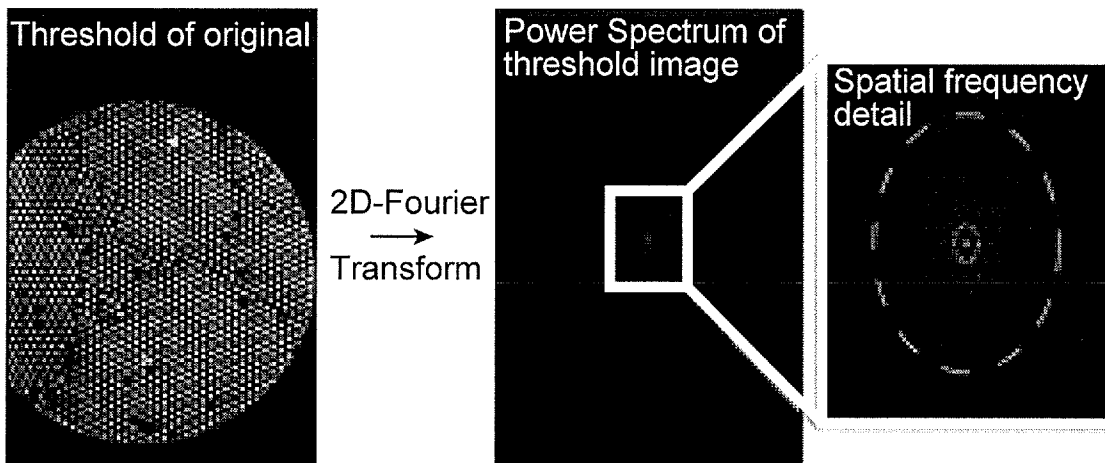

FIG. 19D



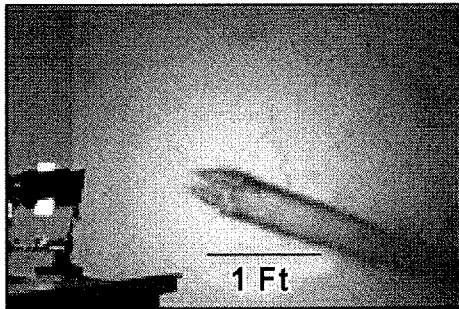

FIG. 21A

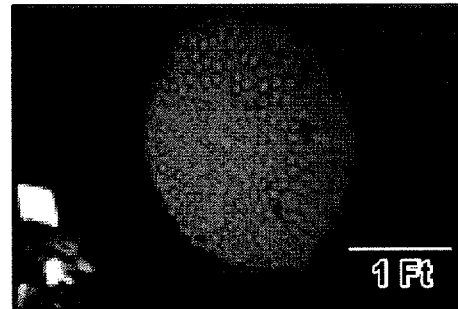

FIG. 21B

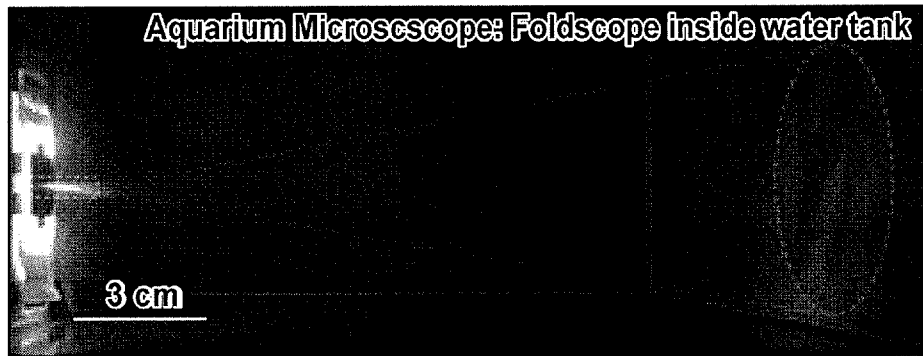

FIG. 22A

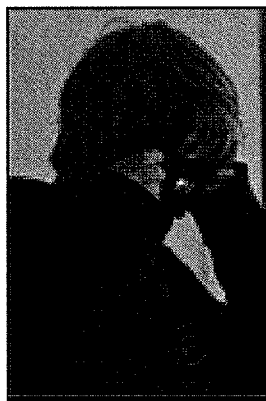

FIG. 22B



FIG. 22C

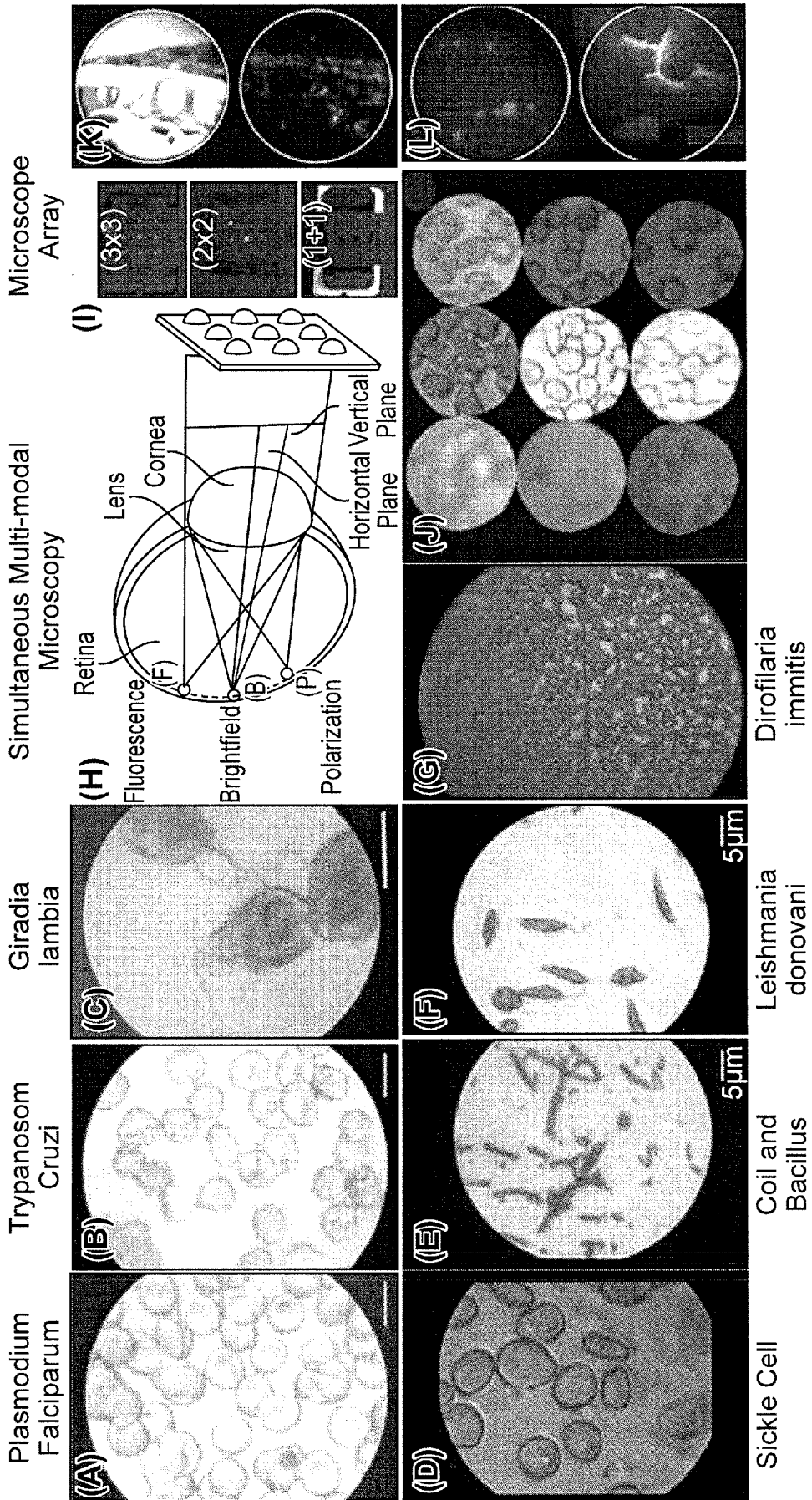
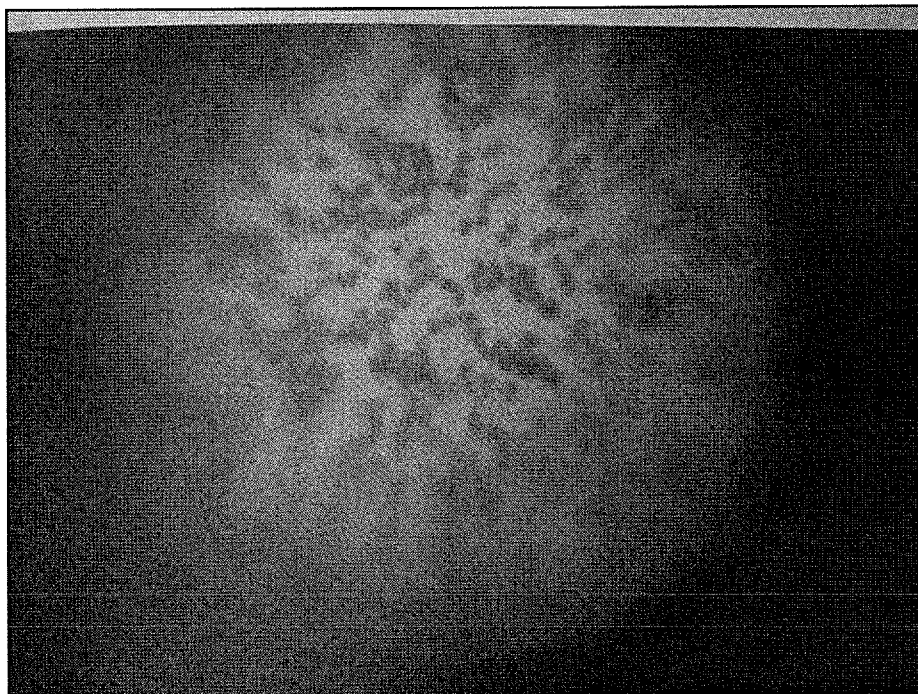

FIG. 23



Human Chromosomes

FIG. 24A



DNA/RNA Stain

FIG. 24B



Spinal Cord

FIG. 24C



Skeletal Muscle

FIG. 24D

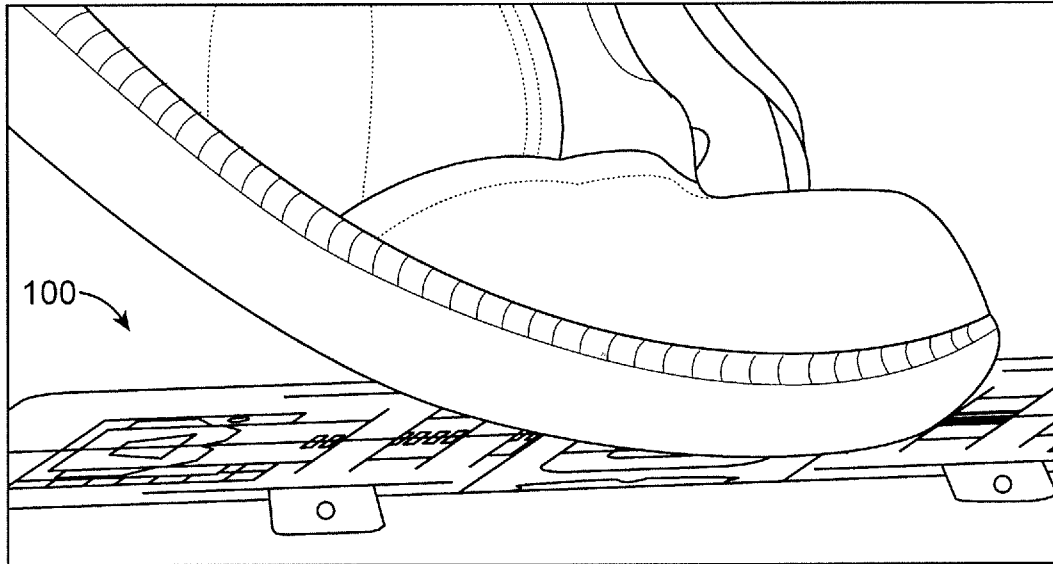

FIG. 25A

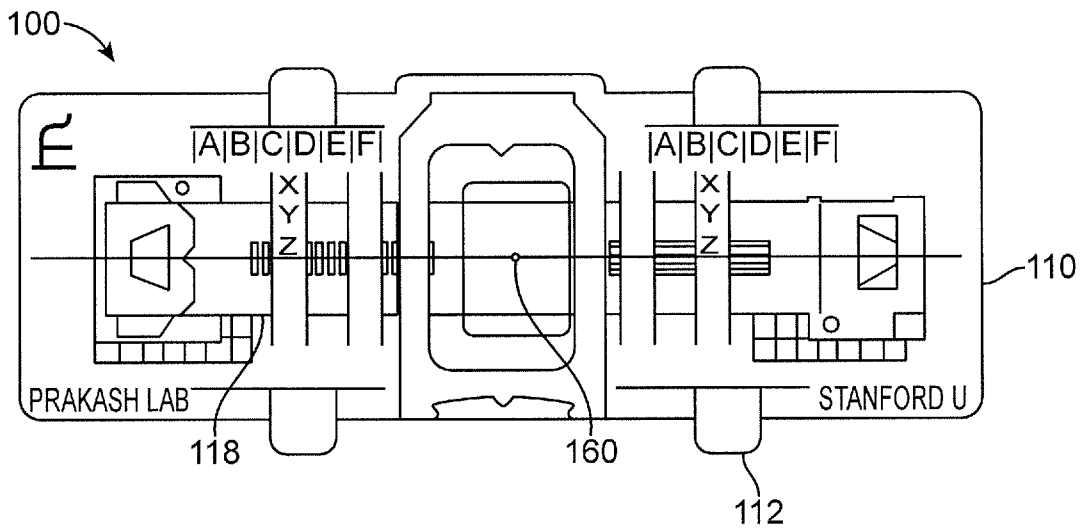

FIG. 25B

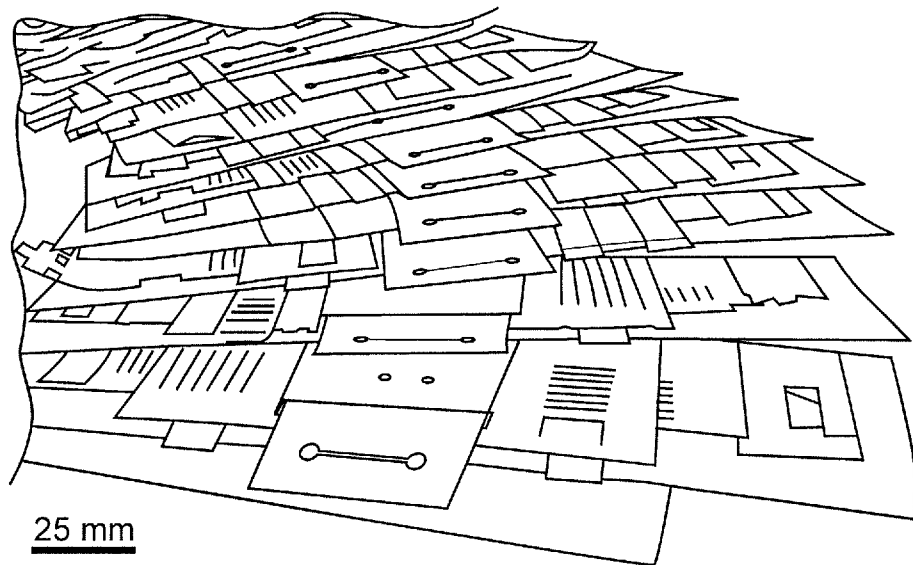

FIG. 26

**A. CLASSIFICATION OF SUBJECT MATTER****G02B 21/00(2006.01)i, G01B 9/04(2006.01)i**

According to International Patent Classification (IPC) or to both national classification and IPC

**B. FIELDS SEARCHED**

Minimum documentation searched (classification system followed by classification symbols)

G02B 21/00; G01B 9/04; G02B 26/10; G01B 11/02; G01N 33/567; G01N 21/00; G01N 33/53; G01N 31/00; G01B 11/00

Documentation searched other than minimum documentation to the extent that such documents are included in the fields searched

Korean utility models and applications for utility models

Japanese utility models and applications for utility models

Electronic data base consulted during the international search (name of data base and, where practicable, search terms used)

eKOMPASS(KIPO internal) &amp; Keywords: optic, microscope, flat, lens, focus and fold

**C. DOCUMENTS CONSIDERED TO BE RELEVANT**

Category*	Citation of document, with indication, where appropriate, of the relevant passages	Relevant to claim No.
X Y A	US 2010-0259805 A1 (OSIPCHUK, YURI VLADIMIROVICH) 14 October 2010 See paragraphs 3-17,25,38-45,51-65 and figures 4-8.	1-3,5-7,9,11-15 ,17-18,21-23,25,41 4,8,10,16,24,26-32 ,36-38,43-47,49-50 ,52 19-20,33-35,39-40 ,42,48,51
Y	US 2002-0173045 A1 (SCHWARTZ, DAVID C.) 21 November 2002 See paragraphs 5-6,46,94,172,242 and figures 1-3.	4,8,10,16,24,26-32
Y	US 2011-0043796 A1 (MARKWORT et al.) 24 February 2011 See paragraphs 4-42 and figures 5,7b.	36-38
Y	US 2004-0142386 A1 (RIGLER et al.) 22 July 2004 See paragraphs 92,155,329-350 and figures 14-16.	43-47,49-50,52
A	JP 2003-294419 A (HITACHI KOKUSAI ELECTRIC INC.) 15 October 2003 See abstract and paragraphs 13-23.	1-52

 Further documents are listed in the continuation of Box C. See patent family annex.

\* Special categories of cited documents:

"A" document defining the general state of the art which is not considered to be of particular relevance

"E" earlier application or patent but published on or after the international filing date

"L" document which may throw doubts on priority claim(s) or which is cited to establish the publication date of citation or other special reason (as specified)

"O" document referring to an oral disclosure, use, exhibition or other means

"P" document published prior to the international filing date but later than the priority date claimed

"T" later document published after the international filing date or priority date and not in conflict with the application but cited to understand the principle or theory underlying the invention

"X" document of particular relevance; the claimed invention cannot be considered novel or cannot be considered to involve an inventive step when the document is taken alone

"Y" document of particular relevance; the claimed invention cannot be considered to involve an inventive step when the document is combined with one or more other such documents, such combination being obvious to a person skilled in the art

"&amp;" document member of the same patent family

Date of the actual completion of the international search

30 May 2013 (30.05.2013)

Date of mailing of the international search report

**02 June 2013 (02.06.2013)**

Name and mailing address of the ISA/KR

 Korean Intellectual Property Office  
 189 Cheongsa-ro, Seo-gu, Daejeon Metropolitan City,  
 302-701, Republic of Korea

Facsimile No. 82-42-472-7140

Authorized officer

AHN, Jae Yul

Telephone No. 82-42-481-8525



## INTERNATIONAL SEARCH REPORT

Information on patent family members

International application No.

**PCT/US2013/025612**

Patent document cited in search report	Publication date	Patent family member(s)	Publication date
US 2010-0259805 A1	14.10.2010	None	
US 2002-0173045 A1	21.11.2002	AU 2003-301262 A1 CA 2173156 C EP 0359589 A2 EP 0359589 A3 EP 0391674 A2 EP 0391674 A3 EP 0391674 B1 EP 0871640 A1 EP 1914238 A2 EP 1914238 A3 JP 03650617 B2 JP 04495767 B2 JP 04511636 B2 JP 2004-065254 A JP 2009-022284 A US 2003-0027201 A1 US 2003-0036067 A1 US 2003-0124611 A1 US 2005-0082204 A1 US 2006-0088944 A1 US 5405519 A US 5599664 A US 5720928 A US 6147198 A US 6150089 A US 6294136 B1 US 6448012 B1 US 6509158 B1 US 6610256 B2 US 6713263 B2 US 7049074 B2 US 7775368 B2 US 8142708 B2	04.05.2004 18.12.2007 21.03.1990 28.11.1990 10.10.1990 10.06.1992 20.03.1996 28.01.2004 23.04.2008 05.11.2008 25.05.2005 16.04.2010 14.05.2010 04.03.2004 05.02.2009 06.02.2003 20.02.2003 03.07.2003 21.04.2005 27.04.2006 11.04.1995 04.02.1997 24.02.1998 14.11.2000 21.11.2000 25.09.2001 10.09.2002 21.01.2003 26.08.2003 30.03.2004 23.05.2006 17.08.2010 27.03.2012
US 2011-0043796 A1	24.02.2011	CN 102016554 A DE 112009000832 T5 JP 2011-516844 A KR 10-2011-0000560 A US 2010-0231902 A1 US 2011-0043798 A1 US 8072591 B2 US 8102521 B2 US 8345232 B2 WO 2009-121628 A2 WO 2009-121628 A9	13.04.2011 28.07.2011 26.05.2011 03.01.2011 16.09.2010 24.02.2011 06.12.2011 24.01.2012 01.01.2013 08.10.2009 26.11.2009
US 2004-0142386 A1	22.07.2004	EP 0679251 A1	28.01.1998

**INTERNATIONAL SEARCH REPORT**

Information on patent family members

International application No.  
**PCT/US2013/025612**

Patent document cited in search report	Publication date	Patent family member(s)	Publication date
		EP 0679251 B1	08.04.1998
		JP 03517241 B2	30.01.2004
		US 2007-0243525 A1	18.10.2007
		US 6582903 B1	24.06.2003
		US 7241569 B2	10.07.2007
		US 7534576 B2	19.05.2009
		WO 1994-016313 A3	21.07.1994
JP 2003-294419 A	15.10.2003	None	