

J. C. KNUCKLES.
 COMBINED AUGER AND REAMER.
 APPLICATION FILED AUG. 24, 1910.

998,534.

Patented July 18, 1911.

2 SHEETS—SHEET 1.

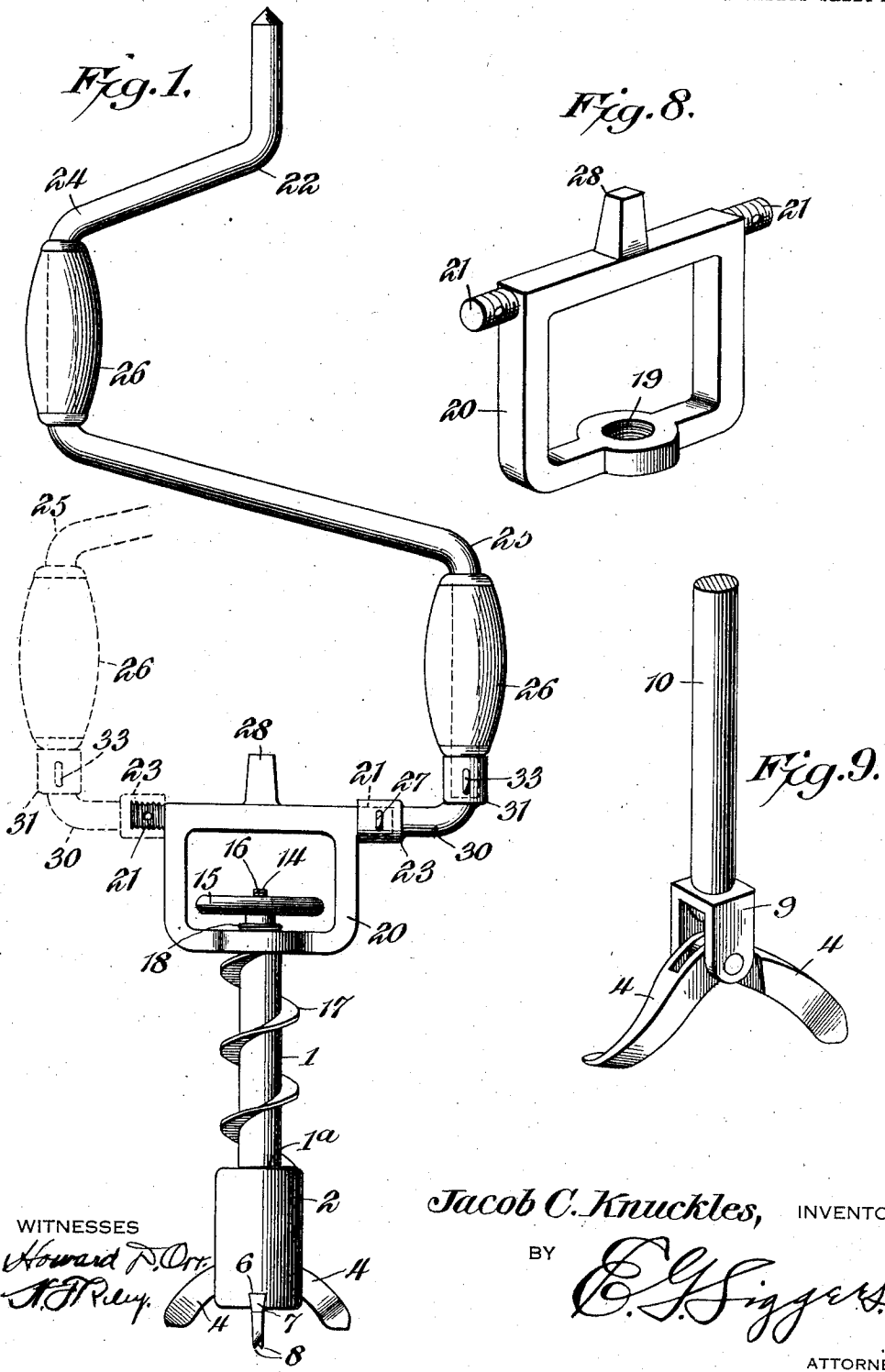

WITNESSES

Howard D. Orr
H. H. Riley

Jacob C. Knuckles, INVENTOR

BY

E. J. Siggers

ATTORNEY

J. C. KNUCKLES.
 COMBINED AUGER AND REAMER.
 APPLICATION FILED AUG. 24, 1910.

998,534.

Patented July 18, 1911.

2 SHEETS—SHEET 2.

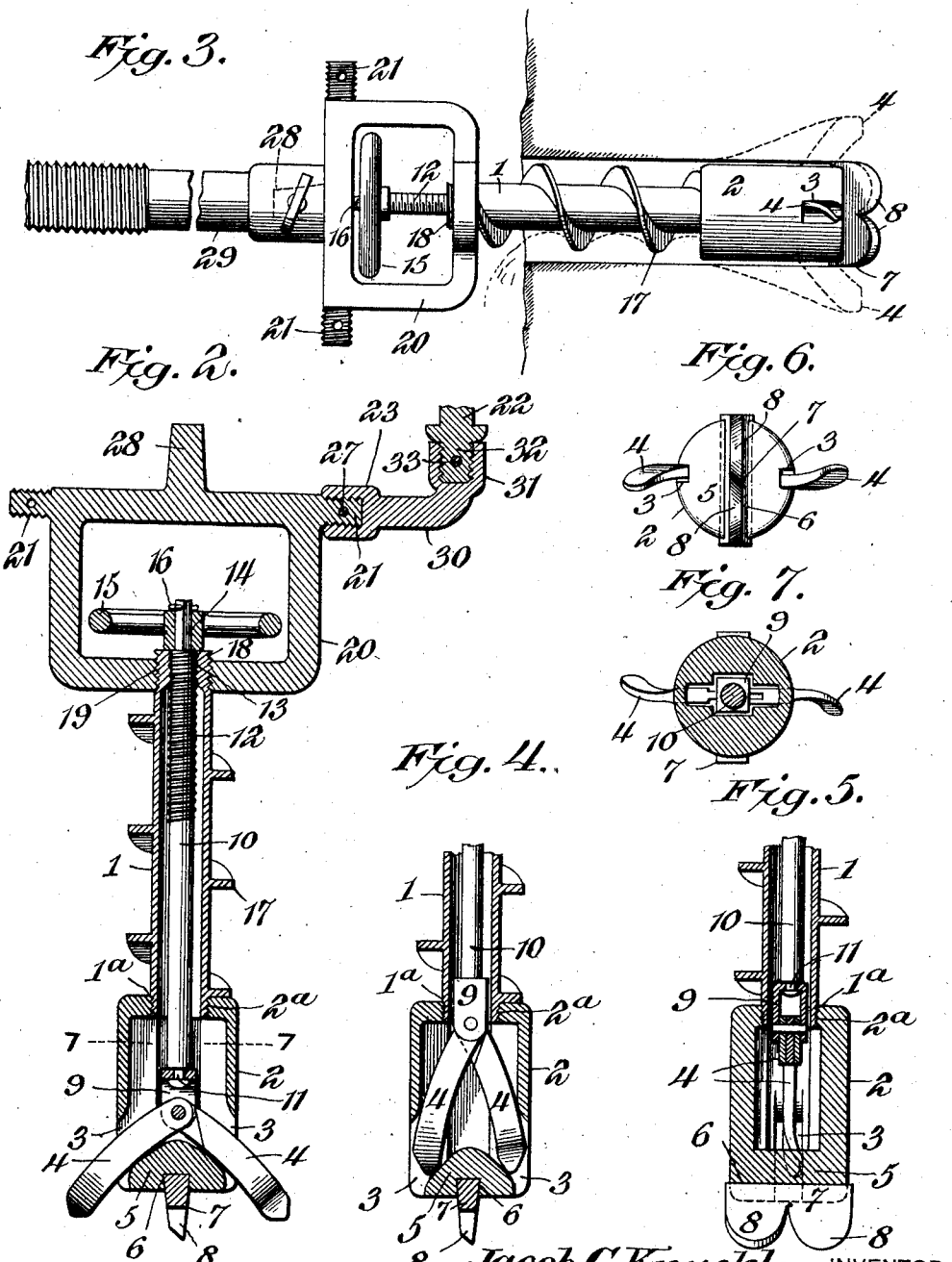

WITNESSES
Howard D. Orr
J. F. Riley

Jacob C. Knuckles, INVENTOR,
 BY *C. J. Siggers*
 ATTORNEY

UNITED STATES PATENT OFFICE.

JACOB C. KNUCKLES, OF FERNDALE, KENTUCKY.

COMBINED AUGER AND REAMER.

998,534.

Specification of Letters Patent. Patented July 18, 1911.

Application filed August 24, 1910. Serial No. 578,646.

To all whom it may concern:

Be it known that I, JACOB C. KNUCKLES, a citizen of the United States, residing at Ferndale, in the county of Bell and State of Kentucky, have invented a new and useful Combined Auger and Reamer, of which the following is a specification.

The invention relates to a combined auger and reamer for boring blast holes.

The object of the present invention is to improve the construction of augers and reamers, and to provide a simple, efficient and comparatively inexpensive tool, designed to be operated either by hand or machine, and adapted to bore a hole in coal and enlarge the inner end thereof so as to get all of the blasting powder in a bulk at the head of the hole, and at the same time afford more room for tamping the hole.

With these and other objects in view, the invention consists in the construction and novel combination of parts hereinafter fully described, illustrated in the accompanying drawings, and pointed out in the claims hereunto appended; it being understood that various changes in the form, proportion, size and minor details of construction, within the scope of the claims, may be resorted to without departing from the spirit or sacrificing any of the advantages of the invention.

In the drawings:—Figure 1 is a side elevation of a combined auger and reamer, constructed in accordance with this invention. Fig. 2 is a central longitudinal sectional view of a portion of the combined auger and reamer. Fig. 3 is a side elevation, the clamping member being detached and the combined auger and reamer being connected with a shaft of a machine. Fig. 4 is a detail sectional view, showing the reaming bits retracted. Fig. 5 is a similar view, taken at right angles to Fig. 4, the drilling bit being shown in elevation. Fig. 6 is an end view. Fig. 7 is a transverse sectional view on the line 7—7 of Fig. 2. Fig. 8 is a detail perspective view of the coupling frame. Fig. 9 is a similar view of the reaming bits, the swivel and the outer portion of the feed screw.

Like numerals of reference designate corresponding parts in all the figures of the drawings.

In the embodiment of the invention illustrated in the accompanying drawings, 1 designates a reduced tubular stem or shank

portion of a barrel, which is provided at the outer end of the shank or stem with an enlarged tubular cutter head 2, having a flat outer end face and provided at the periphery thereof with side openings 3 for a pair of reaming bits 4. The outer end 1^a of the shank 1 is threaded and is screwed into a threaded opening 2^a in the inner end of the head 2. The openings 3 diverge outwardly, and the head 2 has a solid inwardly tapered outer portion 5, and is provided in its flat outer end face with a transverse groove 6 for the reception of a drilling bit 7, which is arranged at right angles to the reaming bits. The transverse groove 6 is tapered in cross section, and the drilling bit 7, which is driven into the groove 6, is tapered to fit the same and is provided with outwardly projecting approximately semi-circular cutting portions 8, which are oppositely beveled and arranged to cut in the forward rotation of the combined auger and reamer.

The reaming bits 4, which are adapted to be extended or projected through the openings 3 after the hole has been bored, are pivotally connected at their inner ends to a yoke 9, which is pivoted or swiveled to the outer end of a feed screw 10. The feed screw has a reduced outer end or pivot 11, which pierces a connecting portion of the yoke and it is headed within the same, as clearly shown in Fig. 2, to retain the yoke on the pivot, but any other suitable means may be employed for connecting the yoke with the feed screw. The feed screw is provided with an inner threaded portion 12, which engages interior threads 13 of the inner end of the tubular shank or stem 1. The inner end 14 of the feed screw is squared to receive a hand wheel 15, or other suitable operating device, and it is provided with a key 16, or other suitable means for retaining the operating handle on the polygonal portion of the feed screw. The feed shaft, which has a smooth outer portion, is adapted to be rotated to move it inwardly and outwardly and to project the reaming bits through the openings of the tubular head, and to draw them within the same.

The tubular shank or stem of the barrel is provided with an integral spiral web or flange 17, which is adapted to feed outward the dust resulting from the boring of the coal. The inner end of the shank or stem 1 is also provided with exterior threads 18, and is screwed into a front central opening

19 of an approximately rectangular coupling frame 20. The frame 20 is composed of spaced sides and front and rear connecting portions, and it is provided at opposite sides of its rear portion with laterally projecting studs 21, adapted to receive a crank member 22. The crank member 22, which is provided at its inner end with a threaded socket 23 to screw on either stud 21, has opposite crank bends 24 and 25, which are equipped with suitable grips 26. The opposite crank bends enable both hands to be used in operating the combined auger and reamer, when the drilling is done by hand. A pair of the studs 21 is provided so that when one is worn the crank member may be applied to the other. The socket 23 is held against rotary movement on the stud by a pin or key 27, and the coupling frame 20 is provided at its rear end with a central tapered shank 28 to enable the combined auger and reamer to be applied to the shaft 29 of a machine when the crank member is detached, whereby the combined auger and reamer may be operated either by hand or machine. The crank member is provided at its inner end with a removable arm 30, having an interiorly threaded socket 31 for the reception of the threaded end 32 of the body portion of the crank member. The body portion of the crank member is removed from the arm prior to detaching the latter from the coupling frame, and the parts of the crank member are held against rotary movement by a transverse pin or key 33, which pierces the socket 31 and the threaded end 32.

Having thus fully described my invention, what I claim as new and desire to secure by Letters Patent, is:—

1. A device of the class described including a coupling frame provided with a laterally projecting stud and having a shank projecting from its rear end, a cutter head carried by the coupling frame, a crank member, and a separate arm constituting a continuation of the inner portion of the crank

member and detachably secured thereto and provided with a socket detachably fitted onto the said stud.

2. A device of the class described including a tubular stem provided at the outer end with a head having openings, reaming bits adapted to extend through the openings of the head, a feed screw operating within the stem and connected with the reaming bits, a coupling frame connected with the inner end of the stem and provided with an opening and having means for connecting it with an operating element, and a handle connected with the feed screw and operating within the opening of the frame.

3. A device of the class described comprising a coupling frame having an opening and provided at opposite sides with studs and having a central shank, and cutting mechanism carried by the coupling frame and including cutters, and mechanism for projecting the cutters, said mechanism having operating means located within the opening of the coupling frame.

4. A device of the class described including a shank having threaded outer and inner ends, a head provided at opposite sides with openings and having a threaded opening at its inner end to receive the outer end of the shank, a coupling frame provided at the front with a threaded opening receiving the inner end of the shank, the latter being also provided with interior screw threads, a feed screw engaging the interior threads of the shank, reaming bits connected with the feed screw and arranged to extend through the side openings of the head, and means located within the frame for operating the feed screw.

In testimony, that I claim the foregoing as my own, I have hereto affixed my signature in the presence of two witnesses.

JACOB C. KNUCKLES.

Witnesses:

HENRY BROUGHTON,
LEANDER J. PURSIFULL.