



(51) International Patent Classification:

A61B 19/00 (2006.01) A61F 9/007 (2006.01)
A61B 17/32 (2006.01) A61B 17/29 (2006.01)

(21) International Application Number:

PCT/US2013/045641

(22) International Filing Date:

13 June 2013 (13.06.2013)

(25) Filing Language:

English

(26) Publication Language:

English

(30) Priority Data:

13/538,733 29 June 2012 (29.06.2012) US

(71) Applicant: **ETHICON ENDO-SURGERY, INC.** [US/US]; 4545 Creek Road, #97, Cincinnati, Ohio 45242 (US).

(72) Inventors: **GEE, Jacob S.**; 5060 Lord Alfred Court, Cincinnati, Ohio 45241 (US). **STULEN, Foster B.**; 6245 Bridgewater Court, Mason, Ohio 45040 (US). **HOUSER, Kevin L.**; 570 Foliage Lane, Springboro, Ohio 45066 (US). **FALLER, Craig N.**; 5960 E. Day Circle, Milford, Ohio 45150 (US). **STROBL, Geoffrey S.**; 15993 Colonial Drive, Williamsburg, Ohio 45176 (US). **RHEE, Sora**; 353 West 4th Street, Cincinnati, Ohio 45202 (US). **DANNAHER, William D.**; Room 104, Block 7, Horizon Resort Phase 1, 188 Xinghan Street, Suzhou, Jiangsu 215021 (CN). **WORRELL, Barry C.**; 1647 Lago Mar Drive,

Centerville, Ohio 45458 (US). **JOHNSON, Gregory W.**; 1 Little Creek Lane, Milford, Ohio 45150 (US).

(74) Agents: **JOHNSON, Philip S.** et al.; JOHNSON & JOHNSON, One Johnson & Johnson Plaza, New Brunswick, New Jersey 08933 (US).

(81) Designated States (unless otherwise indicated, for every kind of national protection available): AE, AG, AL, AM, AO, AT, AU, AZ, BA, BB, BG, BH, BN, BR, BW, BY, BZ, CA, CH, CL, CN, CO, CR, CU, CZ, DE, DK, DM, DO, DZ, EC, EE, EG, ES, FI, GB, GD, GE, GH, GM, GT, HN, HR, HU, ID, IL, IN, IS, JP, KE, KG, KN, KP, KR, KZ, LA, LC, LK, LR, LS, LT, LU, LY, MA, MD, ME, MG, MK, MN, MW, MX, MY, MZ, NA, NG, NI, NO, NZ, OM, PA, PE, PG, PH, PL, PT, QA, RO, RS, RU, RW, SC, SD, SE, SG, SK, SL, SM, ST, SV, SY, TH, TJ, TM, TN, TR, TT, TZ, UA, UG, US, UZ, VC, VN, ZA, ZM, ZW.

(84) Designated States (unless otherwise indicated, for every kind of regional protection available): ARIPO (BW, GH, GM, KE, LR, LS, MW, MZ, NA, RW, SD, SL, SZ, TZ, UG, ZM, ZW), Eurasian (AM, AZ, BY, KG, KZ, RU, TJ, TM), European (AL, AT, BE, BG, CH, CY, CZ, DE, DK, EE, ES, FI, FR, GB, GR, HR, HU, IE, IS, IT, LT, LU, LV, MC, MK, MT, NL, NO, PL, PT, RO, RS, SE, SI, SK, SM, TR), OAPI (BF, BJ, CF, CG, CI, CM, GA, GN, GQ, GW, KM, ML, MR, NE, SN, TD, TG).

Declarations under Rule 4.17:

— as to the identity of the inventor (Rule 4.17(i))

[Continued on next page]

(54) Title: ULTRASONIC SURGICAL INSTRUMENTS WITH CONTROL MECHANISMS

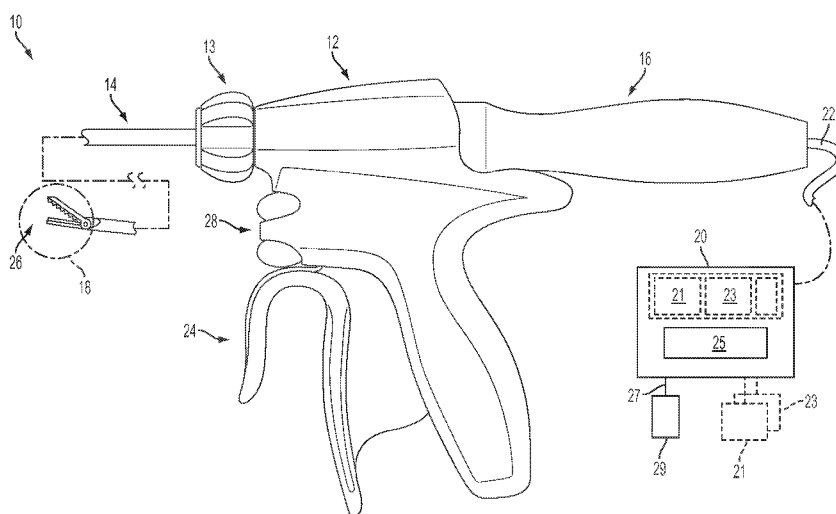

FIG. 1

(57) Abstract: Various embodiments are directed to surgical instruments for use in handheld applications or with robotic surgical systems. The surgical instruments may comprise an end effector to treat tissue and a shaft extending proximally from the end effector along a longitudinal axis. Some embodiments may be usable with an instrument mounting portion of a robotic surgical instrument. For example, the shaft may extend proximally to the instrument mounting portion.



- *as to applicant's entitlement to apply for and be granted a patent (Rule 4.17(ii))*
 - *as to the applicant's entitlement to claim the priority of the earlier application (Rule 4.17(iii))*
- Published:**
- *with international search report (Art. 21(3))*
 - *before the expiration of the time limit for amending the claims and to be republished in the event of receipt of amendments (Rule 48.2(h))*

TITLE**ULTRASONIC SURGICAL INSTRUMENTS WITH CONTROL MECHANISMS****CROSS-REFERENCE TO RELATED APPLICATIONS**

[0001] The present application is related to the following, concurrently-filed U.S. Patent Applications, which are incorporated herein by reference in their entirety:

[0002] U.S. Application Serial No. _____, entitled "Haptic Feedback Devices for Surgical Robot," Attorney Docket No. END7042USNP/110388;

[0003] U.S. Application Serial No. _____, entitled "Lockout Mechanism for Use with Robotic Electrosurgical Device," Attorney Docket No. END7043USNP/110389;

[0004] U.S. Application Serial No. _____, entitled "Closed Feedback Control for Electrosurgical Device," Attorney Docket No. END7044USNP/110390;

[0005] U.S. Application Serial No. _____, entitled "Surgical Instruments with Articulating Shafts," Attorney Docket No. END6423USNP/110392;

[0006] U.S. Application Serial No. _____, entitled "Ultrasonic Surgical Instruments with Distally Positioned Transducers," Attorney Docket No. END6819USNP/110393;

[0007] U.S. Application Serial No. _____, entitled "Surgical Instruments with Articulating Shafts," Attorney Docket No. END7047USNP/110394;

[0008] U.S. Application Serial No. _____, entitled "Ultrasonic Surgical Instruments with Distally Positioned Jaw Assemblies," Attorney Docket No. END7048USNP/110395;

[0009] U.S. Application Serial No. _____, entitled "Surgical Instruments with Articulating Shafts," Attorney Docket No. END7049USNP/110396;

[0010] U.S. Application Serial No. _____, entitled "Surgical Instruments With Fluid Management System" Attorney Docket No. END7051USNP/110399.

BACKGROUND

[0011] Various embodiments are directed to surgical instruments including various control mechanisms for surgical instruments.

[0012] Ultrasonic surgical devices, such as ultrasonic scalpels, are used in many applications in surgical procedures by virtue of their unique performance characteristics. Depending upon specific device configurations and operational parameters, ultrasonic surgical devices can provide substantially simultaneous transection of tissue and homeostasis by coagulation, desirably minimizing patient trauma. An ultrasonic surgical device comprises a proximally-positioned ultrasonic transducer and an instrument coupled to the ultrasonic transducer having a distally-mounted end effector comprising an ultrasonic blade to cut and seal tissue. The end effector is typically coupled either to a handle and/or a robotic surgical implement via a shaft. The blade is acoustically coupled to the transducer via a waveguide extending through the shaft. Ultrasonic surgical devices of this nature can be configured for open surgical use, laparoscopic, or endoscopic surgical procedures including robotic-assisted procedures.

[0013] Ultrasonic energy cuts and coagulates tissue using temperatures lower than those used in electrosurgical procedures. Vibrating at high frequencies (*e.g.*, 55,500 times per second), the ultrasonic blade denatures protein in the tissue to form a sticky coagulum. Pressure exerted on tissue by the blade surface collapses blood vessels and allows the coagulum to form a hemostatic seal. A surgeon can control the cutting speed and coagulation by the force applied to the tissue by the end effector, the time over which the force is applied and the selected excursion level of the end effector.

DRAWINGS

[0014] The features of the various embodiments are set forth with particularity in the appended claims. The various embodiments, however, both as to organization and methods of operation, together with advantages thereof, may best be understood by reference to the following description, taken in conjunction with the accompanying drawings as follows:

[0015] FIG. 1 illustrates one embodiment of a surgical system including a surgical instrument and an ultrasonic generator.

[0016] FIG. 2 illustrates one embodiment of the surgical instrument shown in FIG. 1.

[0017] FIG. 3 illustrates one embodiment of an ultrasonic end effector.

[0018] FIG. 4 illustrates another embodiment of an ultrasonic end effector.

[0019] FIG. 5 illustrates an exploded view of one embodiment of the surgical instrument shown in FIG. 1.

[0020] FIG. 6 illustrates a cut-away view of one embodiment of the surgical instrument shown in FIG. 1.

[0021] FIG. 7 illustrates various internal components of one example embodiment of the surgical instrument shown in FIG. 1.

[0022] FIG. 8 illustrates a top view of one embodiment of a surgical system including a surgical instrument and an ultrasonic generator.

[0023] FIG. 9 illustrates one embodiment of a rotation assembly included in one example embodiment of the surgical instrument of FIG. 1.

[0024] FIG. 10 illustrates one embodiment of a surgical system including a surgical instrument having a single element end effector.

[0025] FIG. 11 is a perspective view of one embodiment of an electrical energy surgical instrument.

[0026] FIG. 12 is a side view of a handle of one embodiment of the surgical instrument of FIG. 11 with a half of a handle body removed to illustrate some of the components therein.

[0027] FIG. 13 illustrates a perspective view of one embodiment of the end effector of the surgical instrument of FIG. 11 with the jaws open and the distal end of an axially movable member in a retracted position.

[0028] FIG. 14 illustrates a perspective view of one embodiment of the end effector of the surgical instrument of FIG. 11 with the jaws closed and the distal end of an axially movable member in a partially advanced position.

[0029] FIG. 15 illustrates a perspective view of one embodiment of the axially moveable member of the surgical instrument of FIG. 11.

[0030] FIG. 16 illustrates a section view of one embodiment of the end effector of the surgical instrument of FIG. 11.

[0031] FIG. 17 illustrates a section a perspective view of one embodiment of a cordless electrical energy surgical instrument.

[0032] FIG. 18A illustrates a side view of a handle of one embodiment of the surgical instrument of FIG. 17 with a half handle body removed to illustrate various components therein.

[0033] FIG. 18B illustrates an RF drive and control circuit, according to one embodiment.

[0034] FIG. 18C illustrates the main components of the controller, according to one embodiment.

[0035] FIG. 19 illustrates a block diagram of one embodiment of a robotic surgical system.

[0036] FIG. 20 illustrates one embodiment of a robotic arm cart.

[0037] FIG. 21 illustrates one embodiment of the robotic manipulator of the robotic arm cart of FIG. 20.

[0038] FIG. 22 illustrates one embodiment of a robotic arm cart having an alternative set-up joint structure.

[0039] FIG. 23 illustrates one embodiment of a controller that may be used in conjunction with a robotic arm cart, such as the robotic arm carts of FIGS. 19-22.

[0040] FIG. 24 illustrates one embodiment of an ultrasonic surgical instrument adapted for use with a robotic system.

[0041] FIG. 25 illustrates one embodiment of an electrosurgical instrument adapted for use with a robotic system.

[0042] FIG. 26 illustrates one embodiment of an instrument drive assembly that may be coupled to a surgical manipulators to receive and control the surgical instrument shown in FIG. 24.

[0043] FIG. 27 illustrates another view of the instrument drive assembly embodiment of FIG. 26 including the surgical instrument of FIG. 24.

[0044] FIG. 28 illustrates another view of the instrument drive assembly embodiment of FIG. 26 including the electrosurgical instrument of FIG. 25.

[0045] FIGS. 29-31 illustrate additional views of the adapter portion of the instrument drive assembly embodiment of FIG. 26.

[0046] FIGS. 32-34 illustrate one embodiment of the instrument mounting portion of FIGS. 24-25 showing components for translating motion of the driven elements into motion of the surgical instrument.

[0047] FIGS. 35-37 illustrate an alternate embodiment of the instrument mounting portion of FIGS. 24-25 showing an alternate example mechanism for translating rotation of the

driven elements into rotational motion about the axis of the shaft and an alternate example mechanism for generating reciprocating translation of one or more members along the axis of the shaft 538.

[0048] FIGS. 38-42 illustrate an alternate embodiment of the instrument mounting portion FIGS. 24-25 showing another alternate example mechanism for translating rotation of the driven elements into rotational motion about the axis of the shaft.

[0049] FIGS. 43-46A illustrate an alternate embodiment of the instrument mounting portion showing an alternate example mechanism for differential translation of members along the axis of the shaft (*e.g.*, for articulation).

[0050] FIGS. 46B-46C illustrate one embodiment of a tool mounting portion comprising internal power and energy sources.

[0051] FIG. 47 illustrates a schematic cross-sectional view of a portion of one example embodiment of an ultrasonic medical instrument comprising first, second and third waveguide portions, where the second waveguide portion is substantially $\frac{1}{2}$ of a resonant-longitudinal-wavelength long.

[0052] FIG. 47A illustrates cross sections for two example embodiments of the second waveguide portion of FIG. 47.

[0053] FIG. 48 illustrates a schematic cross-sectional view of a portion of one example embodiment of an ultrasonic medical instrument comprising first and second waveguide portions, where the first waveguide portion spans multiple $\frac{1}{2}$ resonant longitudinal wavelengths.

[0054] FIG. 49 illustrates a schematic cross-sectional view of one example embodiment of an ultrasonic waveguide for use with a medical instrument and comprising first and second waveguide portions, where a first waveguide portion is joined to a second waveguide portion by a dowel press fit.

[0055] FIG. 50 illustrates a schematic cross-sectional view of one example embodiment of an ultrasonic waveguide for use with a medical instrument and comprising first and second waveguide portions, where the first waveguide portion is joined to the second waveguide portion by a ball-and-socket type attachment.

[0056] FIG. 51 illustrates a schematic cross-sectional view of a portion of another embodiment of an ultrasonic medical instrument comprising a medical ultrasonic waveguide having a length and including a proximal waveguide portion and a distal waveguide portion.

[0057] FIG. 52 illustrates one embodiment of an instrument mounting portion for use with a robotic surgical system, such as the system of FIG. 19, comprising a magnetic element-driven control mechanism.

[0058] FIGS. 53A-G illustrate one embodiment of the rotatable body and magnetic elements of the instrument mounting portion of FIG. 52, with the rotatable body at various angular positions to energize and/or de-energize combinations of the magnetic elements.

[0059] FIG. 54 illustrates another embodiment of an instrument mounting portion for use with a robotic surgical system, such as the system of FIG. 19, comprising a magnetic element-driven control mechanism.

[0060] FIG. 55 illustrates another embodiment of an instrument mounting portion for use with a robotic surgical system, such as the system of FIG. 19, comprising a magnetic element-driven control mechanism and a spool-driven control mechanism.

[0061] FIGS. 56-57 illustrate one embodiment of an instrument mounting portion for use with a robotic surgical system, such as the system of FIG. 19, comprising a translatable cable driven by a pair of rotatable bodies.

[0062] FIG. 58 illustrates another embodiment of an instrument mounting portion for use with a robotic surgical system, such as the system of FIG. 19, comprising a translatable cable driven by a pair of rotatable bodies.

[0063] FIGS. 59-62 illustrate one embodiment of an articulation mechanism that may be utilized by manual and/or robotic surgical instruments to articulate an end effector.

[0064] FIGS. 63A-B illustrate one embodiment of an articulation mechanism that may be utilized with any suitable control mechanism, including those described above with respect to FIGS. 52-58.

[0065] FIGS. 64-65 illustrate embodiments of the plate of the articulation mechanism of FIGS. 63A-B configured for use with three and four cables, respectively.

[0066] FIGS. 66-67 illustrate one embodiment of a shaft portion of a surgical instrument utilizing an articulation mechanism similar to the mechanism of FIGS. 63A-63B.

[0067] FIG. 68 illustrates one embodiment of a surgical instrument for use with a robotic surgical system, such as the system of FIG. 19, comprising a translatable end effector.

[0068] FIG. 69A illustrates one embodiment of an articulatable shaft portion that may be used in conjunction with a surgical instrument.

[0069] FIG. 69B illustrates an additional view of one embodiment of the flexible articulation portion of the shaft portion of FIG. 69A.

[0070] FIG. 70 illustrates one embodiment of a piece of flat stock with a pair of coil pipes welded thereto.

[0071] FIG. 71 illustrates one embodiment of the flat stock of FIG. 70 rolled into a tube shape.

[0072] FIG. 72 illustrates one embodiment of an instrument mounting portion that may be utilized to effect differential translation of the cables of FIG. 70.

[0073] FIG. 73 illustrates one embodiment of an instrument mounting portion comprising a battery assembly for powering the at least one energy element.

[0074] FIG. 74 illustrates one embodiment of the instrument mounting portion of FIG. 73 further comprising a generator circuit.

[0075] FIG. 75 illustrates one embodiment of an instrument mounting portion with a cord-based generator circuit.

[0076] FIG. 76 illustrates one embodiment of an instrument mounting portion comprising a removable battery assembly.

[0077] FIG. 77 illustrates one embodiment of a surgical system with a wireless foot pedal for actuating an energy element.

[0078] FIGS. 78-83 illustrate one embodiment of a passive articulation mechanism for use with a robotic surgical system and/or manual surgical instrument.

DESCRIPTION

[0079] Various embodiments are directed to surgical instruments, including control mechanisms for handheld instruments and/or instruments for use with robotic surgical applications. The control mechanisms may be utilized to perform various actions with the surgical instruments including, for example, articulation of an end effector, actuation of various mechanical and/or energy elements of the surgical instruments, *etc.* In some embodiments, control mechanisms are positioned within an instrument mounting device for use with a robotic surgical system.

[0080] Reference will now be made in detail to several embodiments, including embodiments showing example implementations of manual and robotic surgical instruments with

end effectors comprising ultrasonic and/or electrosurgical elements. Wherever practicable similar or like reference numbers may be used in the figures and may indicate similar or like functionality. The figures depict example embodiments of the disclosed surgical instruments and/or methods of use for purposes of illustration only. One skilled in the art will readily recognize from the following description that alternative example embodiments of the structures and methods illustrated herein may be employed without departing from the principles described herein.

[0081] FIG. 1 is a right side view of one embodiment of an ultrasonic surgical instrument 10. In the illustrated embodiment, the ultrasonic surgical instrument 10 may be employed in various surgical procedures including endoscopic or traditional open surgical procedures. In one example embodiment, the ultrasonic surgical instrument 10 comprises a handle assembly 12, an elongated shaft assembly 14, and an ultrasonic transducer 16. The handle assembly 12 comprises a trigger assembly 24, a distal rotation assembly 13, and a switch assembly 28. The elongated shaft assembly 14 comprises an end effector assembly 26, which comprises elements to dissect tissue or mutually grasp, cut, and coagulate vessels and/or tissue, and actuating elements to actuate the end effector assembly 26. The handle assembly 12 is adapted to receive the ultrasonic transducer 16 at the proximal end. The ultrasonic transducer 16 is mechanically engaged to the elongated shaft assembly 14 and portions of the end effector assembly 26. The ultrasonic transducer 16 is electrically coupled to a generator 20 via a cable 22. Although the majority of the drawings depict a multiple end effector assembly 26 for use in connection with laparoscopic surgical procedures, the ultrasonic surgical instrument 10 may be employed in more traditional open surgical procedures and in other embodiments, may be configured for use in endoscopic procedures. For the purposes herein, the ultrasonic surgical instrument 10 is described in terms of an endoscopic instrument; however, it is contemplated that an open and/or laparoscopic version of the ultrasonic surgical instrument 10 also may include the same or similar operating components and features as described herein.

[0082] In various embodiments, the generator 20 comprises several functional elements, such as modules and/or blocks. Different functional elements or modules may be configured for driving different kinds of surgical devices. For example, an ultrasonic generator module 21 may drive an ultrasonic device, such as the ultrasonic surgical instrument 10. In some example embodiments, the generator 20 also comprises an electrosurgery/RF generator module

23 for driving an electrosurgical device (or an electrosurgical embodiment of the ultrasonic surgical instrument 10). In various embodiments, the generator 20 may be formed integrally within the handle assembly 12. In such implementations, a battery would be co-located within the handle assembly 12 to act as the energy source. FIG. 18A and accompanying disclosures provide one example of such implementations.

[0083] In some embodiments, the electrosurgery/RF generator module 23 may be configured to generate a therapeutic and/or a sub-therapeutic energy level. In the example embodiment illustrated in FIG. 1, the generator 20 includes a control system 25 integral with the generator 20, and a foot switch 29 connected to the generator via a cable 27. The generator 20 may also comprise a triggering mechanism for activating a surgical instrument, such as the instrument 10. The triggering mechanism may include a power switch (not shown) as well as a foot switch 29. When activated by the foot switch 29, the generator 20 may provide energy to drive the acoustic assembly of the surgical instrument 10 and to drive the end effector 18 at a predetermined excursion level. The generator 20 drives or excites the acoustic assembly at any suitable resonant frequency of the acoustic assembly and/or derives the therapeutic/sub-therapeutic electromagnetic /RF energy.

[0084] In one embodiment, the electrosurgical /RF generator module 23 may be implemented as an electrosurgery unit (ESU) capable of supplying power sufficient to perform bipolar electrosurgery using radio frequency (RF) energy. In one embodiment, the ESU can be a bipolar ERBE ICC 350 sold by ERBE USA, Inc. of Marietta, Ga. In bipolar electrosurgery applications, as previously discussed, a surgical instrument having an active electrode and a return electrode can be utilized, wherein the active electrode and the return electrode can be positioned against, or adjacent to, the tissue to be treated such that current can flow from the active electrode to the return electrode through the tissue. Accordingly, the electrosurgical/RF module 23 generator may be configured for therapeutic purposes by applying electrical energy to the tissue T sufficient for treating the tissue (e.g., cauterization).

[0085] In one embodiment, the electrosurgical /RF generator module 23 may be configured to deliver a sub-therapeutic RF signal to implement a tissue impedance measurement module. In one embodiment, the electrosurgical /RF generator module 23 comprises a bipolar radio frequency generator as described in more detail below. In one embodiment, the electrosurgical/RF generator module 12 may be configured to monitor electrical impedance Z , of

tissue T and to control the characteristics of time and power level based on the tissue T by way of a return electrode on provided on a clamp member of the end effector assembly 26. Accordingly, the electrosurgical/RF generator module 23 may be configured for sub-therapeutic purposes for measuring the impedance or other electrical characteristics of the tissue T. Techniques and circuit configurations for measuring the impedance or other electrical characteristics of tissue T are discussed in more detail in commonly assigned U.S. Patent Publication No. 2011/0015631, titled "Electrosurgical Generator for Ultrasonic Surgical Instruments," the disclosure of which is herein incorporated by reference in its entirety.

[0086] A suitable ultrasonic generator module 21 may be configured to functionally operate in a manner similar to the GEN300 sold by Ethicon Endo-Surgery, Inc. of Cincinnati, Ohio as is disclosed in one or more of the following U.S. patents, all of which are incorporated by reference herein: U.S. Pat. No. 6,480,796 (Method for Improving the Start Up of an Ultrasonic System Under Zero Load Conditions); U.S. Pat. No. 6,537,291 (Method for Detecting Blade Breakage Using Rate and/or Impedance Information); U.S. Pat. No. 6,662,127 (Method for Detecting Presence of a Blade in an Ultrasonic System); U.S. Pat. No. 6,678,899 (Method for Detecting Transverse Vibrations in an Ultrasonic Surgical System); U.S. Pat. No. 6,977,495 (Detection Circuitry for Surgical Handpiece System); U.S. Pat. No. 7,077,853 (Method for Calculating Transducer Capacitance to Determine Transducer Temperature); U.S. Pat. No. 7,179,271 (Method for Driving an Ultrasonic System to Improve Acquisition of Blade Resonance Frequency at Startup); and U.S. Pat. No. 7,273,483 (Apparatus and Method for Alerting Generator Function in an Ultrasonic Surgical System).

[0087] It will be appreciated that in various embodiments, the generator 20 may be configured to operate in several modes. In one mode, the generator 20 may be configured such that the ultrasonic generator module 21 and the electrosurgical/RF generator module 23 may be operated independently.

[0088] For example, the ultrasonic generator module 21 may be activated to apply ultrasonic energy to the end effector assembly 26 and subsequently, either therapeutic sub-therapeutic RF energy may be applied to the end effector assembly 26 by the electrosurgical /RF generator module 23. As previously discussed, the subtherapeutic electrosurgical/RF energy may be applied to tissue clamped between claim elements of the end effector assembly 26 to measure tissue impedance to control the activation, or modify the activation, of the ultrasonic

generator module 21. Tissue impedance feedback from the application of the subtherapeutic energy also may be employed to activate a therapeutic level of the electrosurgical/RF generator module 23 to seal the tissue (e.g., vessel) clamped between claim elements of the end effector assembly 26.

[0089] In another embodiment, the ultrasonic generator module 21 and the electrosurgical/RF generator module 23 may be activated simultaneously. In one example, the ultrasonic generator module 21 is simultaneously activated with a sub-therapeutic RF energy level to measure tissue impedance simultaneously while the ultrasonic blade of the end effector assembly 26 cuts and coagulates the tissue (or vessel) clamped between the clamp elements of the end effector assembly 26. Such feedback may be employed, for example, to modify the drive output of the ultrasonic generator module 21. In another example, the ultrasonic generator module 21 may be driven simultaneously with electrosurgical/RF generator module 23 such that the ultrasonic blade portion of the end effector assembly 26 is employed for cutting the damaged tissue while the electrosurgical/RF energy is applied to electrode portions of the end effector clamp assembly 26 for sealing the tissue (or vessel).

[0090] When the generator 20 is activated via the triggering mechanism, in one embodiment electrical energy is continuously applied by the generator 20 to a transducer stack or assembly of the acoustic assembly. In another embodiment, electrical energy is intermittently applied (e.g., pulsed) by the generator 20. A phase-locked loop in the control system of the generator 20 may monitor feedback from the acoustic assembly. The phase lock loop adjusts the frequency of the electrical energy sent by the generator 20 to match the resonant frequency of the selected longitudinal mode of vibration of the acoustic assembly. In addition, a second feedback loop in the control system 25 maintains the electrical current supplied to the acoustic assembly at a pre-selected constant level in order to achieve substantially constant excursion at the end effector 18 of the acoustic assembly. In yet another embodiment, a third feedback loop in the control system 25 monitors impedance between electrodes located in the end effector assembly 26. Although FIGS. 1-9 show a manually operated ultrasonic surgical instrument, it will be appreciated that ultrasonic surgical instruments may also be used in robotic applications, for example, as described herein, as well as combinations of manual and robotic applications.

[0091] In ultrasonic operation mode, the electrical signal supplied to the acoustic assembly may cause the distal end of the end effector 18, to vibrate longitudinally in the range

of, for example, approximately 20 kHz to 250 kHz. According to various embodiments, the blade 22 may vibrate in the range of about 54 kHz to 56 kHz, for example, at about 55.5 kHz. In other embodiments, the blade 22 may vibrate at other frequencies including, for example, about 31 kHz or about 80 kHz. The excursion of the vibrations at the blade can be controlled by, for example, controlling the amplitude of the electrical signal applied to the transducer assembly of the acoustic assembly by the generator 20. As noted above, the triggering mechanism of the generator 20 allows a user to activate the generator 20 so that electrical energy may be continuously or intermittently supplied to the acoustic assembly. The generator 20 also has a power line for insertion in an electro-surgical unit or conventional electrical outlet. It is contemplated that the generator 20 can also be powered by a direct current (DC) source, such as a battery. The generator 20 can comprise any suitable generator, such as Model No. GEN04, and/or Model No. GEN11 available from Ethicon Endo-Surgery, Inc.

[0092] FIG. 2 is a left perspective view of one example embodiment of the ultrasonic surgical instrument 10 showing the handle assembly 12, the distal rotation assembly 13, the elongated shaft assembly 14, and the end effector assembly 26. In the illustrated embodiment the elongated shaft assembly 14 comprises a distal end 52 dimensioned to mechanically engage the end effector assembly 26 and a proximal end 50 that mechanically engages the handle assembly 12 and the distal rotation assembly 13. The proximal end 50 of the elongated shaft assembly 14 is received within the handle assembly 12 and the distal rotation assembly 13. More details relating to the connections between the elongated shaft assembly 14, the handle assembly 12, and the distal rotation assembly 13 are provided in the description of FIGS. 5 and 7.

[0093] In the illustrated embodiment, the trigger assembly 24 comprises a trigger 32 that operates in conjunction with a fixed handle 34. The fixed handle 34 and the trigger 32 are ergonomically formed and adapted to interface comfortably with the user. The fixed handle 34 is integrally associated with the handle assembly 12. The trigger 32 is pivotally movable relative to the fixed handle 34 as explained in more detail below with respect to the operation of the ultrasonic surgical instrument 10. The trigger 32 is pivotally movable in direction 33A toward the fixed handle 34 when the user applies a squeezing force against the trigger 32. A spring element 98 (FIG. 5) causes the trigger 32 to pivotally move in direction 33B when the user releases the squeezing force against the trigger 32.

[0094] In one example embodiment, the trigger 32 comprises an elongated trigger hook 36, which defines an aperture 38 between the elongated trigger hook 36 and the trigger 32. The aperture 38 is suitably sized to receive one or multiple fingers of the user therethrough. The trigger 32 also may comprise a resilient portion 32a molded over the trigger 32 substrate. The overmolded resilient portion 32a is formed to provide a more comfortable contact surface for control of the trigger 32 in outward direction 33B. In one example embodiment, the overmolded resilient portion 32a may be provided over a portion of the elongated trigger hook 36. The proximal surface of the elongated trigger hook 32 remains uncoated or coated with a non-resilient substrate to enable the user to easily slide their fingers in and out of the aperture 38. In another embodiment, the geometry of the trigger forms a fully closed loop which defines an aperture suitably sized to receive one or multiple fingers of the user therethrough. The fully closed loop trigger also may comprise a resilient portion molded over the trigger substrate.

[0095] In one example embodiment, the fixed handle 34 comprises a proximal contact surface 40 and a grip anchor or saddle surface 42. The saddle surface 42 rests on the web where the thumb and the index finger are joined on the hand. The proximal contact surface 40 has a pistol grip contour that receives the palm of the hand in a normal pistol grip with no rings or apertures. The profile curve of the proximal contact surface 40 may be contoured to accommodate or receive the palm of the hand. A stabilization tail 44 is located towards a more proximal portion of the handle assembly 12. The stabilization tail 44 may be in contact with the uppermost web portion of the hand located between the thumb and the index finger to stabilize the handle assembly 12 and make the handle assembly 12 more controllable.

[0096] In one example embodiment, the switch assembly 28 may comprise a toggle switch 30. The toggle switch 30 may be implemented as a single component with a central pivot 304 located within inside the handle assembly 12 to eliminate the possibility of simultaneous activation. In one example embodiment, the toggle switch 30 comprises a first projecting knob 30a and a second projecting knob 30b to set the power setting of the ultrasonic transducer 16 between a minimum power level (*e.g.*, MIN) and a maximum power level (*e.g.*, MAX). In another embodiment, the rocker switch may pivot between a standard setting and a special setting. The special setting may allow one or more special programs to be implemented by the device. The toggle switch 30 rotates about the central pivot as the first projecting knob 30a and the second projecting knob 30b are actuated. The one or more projecting knobs 30a, 30b are

coupled to one or more arms that move through a small arc and cause electrical contacts to close or open an electric circuit to electrically energize or de-energize the ultrasonic transducer 16 in accordance with the activation of the first or second projecting knobs 30a, 30b. The toggle switch 30 is coupled to the generator 20 to control the activation of the ultrasonic transducer 16. The toggle switch 30 comprises one or more electrical power setting switches to activate the ultrasonic transducer 16 to set one or more power settings for the ultrasonic transducer 16. The forces required to activate the toggle switch 30 are directed substantially toward the saddle point 42, thus avoiding any tendency of the instrument to rotate in the hand when the toggle switch 30 is activated.

[0097] In one example embodiment, the first and second projecting knobs 30a, 30b are located on the distal end of the handle assembly 12 such that they can be easily accessible by the user to activate the power with minimal, or substantially no, repositioning of the hand grip, making it suitable to maintain control and keep attention focused on the surgical site (*e.g.*, a monitor in a laparoscopic procedure) while activating the toggle switch 30. The projecting knobs 30a, 30b may be configured to wrap around the side of the handle assembly 12 to some extent to be more easily accessible by variable finger lengths and to allow greater freedom of access to activation in awkward positions or for shorter fingers.

[0098] In the illustrated embodiment, the first projecting knob 30a comprises a plurality of tactile elements 30c, *e.g.*, textured projections or “bumps” in the illustrated embodiment, to allow the user to differentiate the first projecting knob 30a from the second projecting knob 30b. It will be appreciated by those skilled in the art that several ergonomic features may be incorporated into the handle assembly 12. Such ergonomic features are described in U.S. Pat. App. Pub. No. 2009/0105750 entitled “Ergonomic Surgical Instruments” which is incorporated by reference herein in its entirety.

[0099] In one example embodiment, the toggle switch 30 may be operated by the hand of the user. The user may easily access the first and second projecting knobs 30a, 30b at any point while also avoiding inadvertent or unintentional activation at any time. The toggle switch 30 may readily operated with a finger to control the power to the ultrasonic assembly 16 and/or to the ultrasonic assembly 16. For example, the index finger may be employed to activate the first contact portion 30a to turn on the ultrasonic assembly 16 to a maximum (MAX) power level. The index finger may be employed to activate the second contact portion 30b to turn on

the ultrasonic assembly 16 to a minimum (MIN) power level. In another embodiment, the rocker switch may pivot the instrument 10 between a standard setting and a special setting. The special setting may allow one or more special programs to be implemented by the instrument 10. The toggle switch 30 may be operated without the user having to look at the first or second projecting knob 30a, 30b. For example, the first projecting knob 30a or the second projecting knob 30b may comprise a texture or projections to tactilely differentiate between the first and second projecting knobs 30a, 30b without looking.

[0100] In other embodiments, the trigger 32 and/or the toggle switch 30 may be employed to actuate the electrosurgical/RF generator module 23 individually or in combination with activation of the ultrasonic generator module 21.

[0101] In one example embodiment, the distal rotation assembly 13 is rotatable without limitation in either direction about a longitudinal axis "T." The distal rotation assembly 13 is mechanically engaged to the elongated shaft assembly 14. The distal rotation assembly 13 is located on a distal end of the handle assembly 12. The distal rotation assembly 13 comprises a cylindrical hub 46 and a rotation knob 48 formed over the hub 46. The hub 46 mechanically engages the elongated shaft assembly 14. The rotation knob 48 may comprise fluted polymeric features and may be engaged by a finger (*e.g.*, an index finger) to rotate the elongated shaft assembly 14. The hub 46 may comprise a material molded over the primary structure to form the rotation knob 48. The rotation knob 48 may be overmolded over the hub 46. The hub 46 comprises an end cap portion 46a that is exposed at the distal end. The end cap portion 46a of the hub 46 may contact the surface of a trocar during laparoscopic procedures. The hub 46 may be formed of a hard durable plastic such as polycarbonate to alleviate any friction that may occur between the end cap portion 46a and the trocar. The rotation knob 48 may comprise "scallops" or flutes formed of raised ribs 48a and concave portions 48b located between the ribs 48a to provide a more precise rotational grip. In one example embodiment, the rotation knob 48 may comprise a plurality of flutes (*e.g.*, three or more flutes). In other embodiments, any suitable number of flutes may be employed. The rotation knob 48 may be formed of a softer polymeric material overmolded onto the hard plastic material. For example, the rotation knob 48 may be formed of pliable, resilient, flexible polymeric materials including Versaflex® TPE alloys made by GLS Corporation, for example. This softer overmolded material may provide a greater grip and more precise control of the movement of the rotation knob 48. It will

be appreciated that any materials that provide adequate resistance to sterilization, are biocompatible, and provide adequate frictional resistance to surgical gloves may be employed to form the rotation knob 48.

[0102] In one example embodiment, the handle assembly 12 is formed from two (2) housing portions or shrouds comprising a first portion 12a and a second portion 12b. From the perspective of a user viewing the handle assembly 12 from the distal end towards the proximal end, the first portion 12a is considered the right portion and the second portion 12b is considered the left portion. Each of the first and second portions 12a, 12b includes a plurality of interfaces 69 (FIG. 5) dimensioned to mechanically align and engage each another to form the handle assembly 12 and enclosing the internal working components thereof. The fixed handle 34, which is integrally associated with the handle assembly 12, takes shape upon the assembly of the first and second portions 12a and 12b of the handle assembly 12. A plurality of additional interfaces (not shown) may be disposed at various points around the periphery of the first and second portions 12a and 12b of the handle assembly 12 for ultrasonic welding purposes, *e.g.*, energy direction/deflection points. The first and second portions 12a and 12b (as well as the other components described below) may be assembled together in any fashion known in the art. For example, alignment pins, snap-like interfaces, tongue and groove interfaces, locking tabs, adhesive ports, may all be utilized either alone or in combination for assembly purposes.

[0103] In one example embodiment, the elongated shaft assembly 14 comprises a proximal end 50 adapted to mechanically engage the handle assembly 12 and the distal rotation assembly 13; and a distal end 52 adapted to mechanically engage the end effector assembly 26. The elongated shaft assembly 14 comprises an outer tubular sheath 56 and a reciprocating tubular actuating member 58 located within the outer tubular sheath 56. The proximal end of the tubular reciprocating tubular actuating member 58 is mechanically engaged to the trigger 32 of the handle assembly 12 to move in either direction 60A or 60B in response to the actuation and/or release of the trigger 32. The pivotably moveable trigger 32 may generate reciprocating motion along the longitudinal axis "T." Such motion may be used, for example, to actuate the jaws or clamping mechanism of the end effector assembly 26. A series of linkages translate the pivotal rotation of the trigger 32 to axial movement of a yoke coupled to an actuation mechanism, which controls the opening and closing of the jaws of the clamping mechanism of the end effector assembly 26. The distal end of the tubular reciprocating tubular actuating

member 58 is mechanically engaged to the end effector assembly 26. In the illustrated embodiment, the distal end of the tubular reciprocating tubular actuating member 58 is mechanically engaged to a clamp arm assembly 64, which is pivotable about a pivot point 70, to open and close the clamp arm assembly 64 in response to the actuation and/or release of the trigger 32. For example, in the illustrated embodiment, the clamp arm assembly 64 is movable in direction 62A from an open position to a closed position about a pivot point 70 when the trigger 32 is squeezed in direction 33A. The clamp arm assembly 64 is movable in direction 62B from a closed position to an open position about the pivot point 70 when the trigger 32 is released or outwardly contacted in direction 33B.

[0104] In one example embodiment, the end effector assembly 26 is attached at the distal end 52 of the elongated shaft assembly 14 and includes a clamp arm assembly 64 and a blade 66. The jaws of the clamping mechanism of the end effector assembly 26 are formed by clamp arm assembly 64 and the blade 66. The blade 66 is ultrasonically actuatable and is acoustically coupled to the ultrasonic transducer 16. The trigger 32 on the handle assembly 12 is ultimately connected to a drive assembly, which together, mechanically cooperate to effect movement of the clamp arm assembly 64. Squeezing the trigger 32 in direction 33A moves the clamp arm assembly 64 in direction 62A from an open position, wherein the clamp arm assembly 64 and the blade 66 are disposed in a spaced relation relative to one another, to a clamped or closed position, wherein the clamp arm assembly 64 and the blade 66 cooperate to grasp tissue therebetween. The clamp arm assembly 64 may comprise a clamp pad 69 to engage tissue between the blade 66 and the clamp arm 64. Releasing the trigger 32 in direction 33B moves the clamp arm assembly 64 in direction 62B from a closed relationship, to an open position, wherein the clamp arm assembly 64 and the blade 66 are disposed in a spaced relation relative to one another.

[0105] The proximal portion of the handle assembly 12 comprises a proximal opening 68 to receive the distal end of the ultrasonic assembly 16. The ultrasonic assembly 16 is inserted in the proximal opening 68 and is mechanically engaged to the elongated shaft assembly 14.

[0106] In one example embodiment, the elongated trigger hook 36 portion of the trigger 32 provides a longer trigger lever with a shorter span and rotation travel. The longer lever of the elongated trigger hook 36 allows the user to employ multiple fingers within the aperture 38 to operate the elongated trigger hook 36 and cause the trigger 32 to pivot in direction 33B to open

the jaws of the end effector assembly 26. For example, the user may insert three fingers (*e.g.*, the middle, ring, and little fingers) in the aperture 38. Multiple fingers allows the surgeon to exert higher input forces on the trigger 32 and the elongated trigger hook 36 to activate the end effector assembly 26. The shorter span and rotation travel creates a more comfortable grip when closing or squeezing the trigger 32 in direction 33A or when opening the trigger 32 in the outward opening motion in direction 33B lessening the need to extend the fingers further outward. This substantially lessens hand fatigue and strain associated with the outward opening motion of the trigger 32 in direction 33B. The outward opening motion of the trigger may be spring-assisted by spring element 98 (FIG. 5) to help alleviate fatigue. The opening spring force is sufficient to assist the ease of opening, but not strong enough to adversely impact the tactile feedback of tissue tension during spreading dissection.

[0107] For example, during a surgical procedure either the index finger may be used to control the rotation of the elongated shaft assembly 14 to locate the jaws of the end effector assembly 26 in a suitable orientation. The middle and/or the other lower fingers may be used to squeeze the trigger 32 and grasp tissue within the jaws. Once the jaws are located in the desired position and the jaws are clamped against the tissue, the index finger can be used to activate the toggle switch 30 to adjust the power level of the ultrasonic transducer 16 to treat the tissue. Once the tissue has been treated, the user may release the trigger 32 by pushing outwardly in the distal direction against the elongated trigger hook 36 with the middle and/or lower fingers to open the jaws of the end effector assembly 26. This basic procedure may be performed without the user having to adjust their grip of the handle assembly 12.

[0108] FIGS. 3-4 illustrate the connection of the elongated shaft assembly 14 relative to the end effector assembly 26. As previously described, in the illustrated embodiment, the end effector assembly 26 comprises a clamp arm assembly 64 and a blade 66 to form the jaws of the clamping mechanism. The blade 66 may be an ultrasonically actuatable blade acoustically coupled to the ultrasonic transducer 16. The trigger 32 is mechanically connected to a drive assembly. Together, the trigger 32 and the drive assembly mechanically cooperate to move the clamp arm assembly 64 to an open position in direction 62A wherein the clamp arm assembly 64 and the blade 66 are disposed in spaced relation relative to one another, to a clamped or closed position in direction 62B wherein the clamp arm assembly 64 and the blade 66 cooperate to grasp tissue therebetween. The clamp arm assembly 64 may comprise a clamp pad 69 to engage

tissue between the blade 66 and the clamp arm 64. The distal end of the tubular reciprocating tubular actuating member 58 is mechanically engaged to the end effector assembly 26. In the illustrated embodiment, the distal end of the tubular reciprocating tubular actuating member 58 is mechanically engaged to the clamp arm assembly 64, which is pivotable about the pivot point 70, to open and close the clamp arm assembly 64 in response to the actuation and/or release of the trigger 32. For example, in the illustrated embodiment, the clamp arm assembly 64 is movable from an open position to a closed position in direction 62B about a pivot point 70 when the trigger 32 is squeezed in direction 33A. The clamp arm assembly 64 is movable from a closed position to an open position in direction 62A about the pivot point 70 when the trigger 32 is released or outwardly contacted in direction 33B.

[0109] As previously discussed, the clamp arm assembly 64 may comprise electrodes electrically coupled to the electrosurgical/RF generator module 23 to receive therapeutic and/or sub-therapeutic energy, where the electrosurgical/RF energy may be applied to the electrodes either simultaneously or non-simultaneously with the ultrasonic energy being applied to the blade 66. Such energy activations may be applied in any suitable combinations to achieve a desired tissue effect in cooperation with an algorithm or other control logic.

[0110] FIG. 5 is an exploded view of the ultrasonic surgical instrument 10 shown in FIG. 2. In the illustrated embodiment, the exploded view shows the internal elements of the handle assembly 12, the handle assembly 12, the distal rotation assembly 13, the switch assembly 28, and the elongated shaft assembly 14. In the illustrated embodiment, the first and second portions 12a, 12b mate to form the handle assembly 12. The first and second portions 12a, 12b each comprises a plurality of interfaces 69 dimensioned to mechanically align and engage one another to form the handle assembly 12 and enclose the internal working components of the ultrasonic surgical instrument 10. The rotation knob 48 is mechanically engaged to the outer tubular sheath 56 so that it may be rotated in circular direction 54 up to 360°. The outer tubular sheath 56 is located over the reciprocating tubular actuating member 58, which is mechanically engaged to and retained within the handle assembly 12 via a plurality of coupling elements 72. The coupling elements 72 may comprise an O-ring 72a, a tube collar cap 72b, a distal washer 72c, a proximal washer 72d, and a thread tube collar 72e. The reciprocating tubular actuating member 58 is located within a reciprocating yoke 84, which is retained between the first and second portions 12a, 12b of the handle assembly 12. The yoke 84 is part of a

reciprocating yoke assembly 88. A series of linkages translate the pivotal rotation of the elongated trigger hook 32 to the axial movement of the reciprocating yoke 84, which controls the opening and closing of the jaws of the clamping mechanism of the end effector assembly 26 at the distal end of the ultrasonic surgical instrument 10. In one example embodiment, a four-link design provides mechanical advantage in a relatively short rotation span, for example.

[0111] In one example embodiment, an ultrasonic transmission waveguide 78 is disposed inside the reciprocating tubular actuating member 58. The distal end 52 of the ultrasonic transmission waveguide 78 is acoustically coupled (*e.g.*, directly or indirectly mechanically coupled) to the blade 66 and the proximal end 50 of the ultrasonic transmission waveguide 78 is received within the handle assembly 12. The proximal end 50 of the ultrasonic transmission waveguide 78 is adapted to acoustically couple to the distal end of the ultrasonic transducer 16 as discussed in more detail below. The ultrasonic transmission waveguide 78 is isolated from the other elements of the elongated shaft assembly 14 by a protective sheath 80 and a plurality of isolation elements 82, such as silicone rings. The outer tubular sheath 56, the reciprocating tubular actuating member 58, and the ultrasonic transmission waveguide 78 are mechanically engaged by a pin 74. The switch assembly 28 comprises the toggle switch 30 and electrical elements 86a,b to electrically energize the ultrasonic transducer 16 in accordance with the activation of the first or second projecting knobs 30a, 30b.

[0112] In one example embodiment, the outer tubular sheath 56 isolates the user or the patient from the ultrasonic vibrations of the ultrasonic transmission waveguide 78. The outer tubular sheath 56 generally includes a hub 76. The outer tubular sheath 56 is threaded onto the distal end of the handle assembly 12. The ultrasonic transmission waveguide 78 extends through the opening of the outer tubular sheath 56 and the isolation elements 82 isolate the ultrasonic transmission waveguide 24 from the outer tubular sheath 56. The outer tubular sheath 56 may be attached to the waveguide 78 with the pin 74. The hole to receive the pin 74 in the waveguide 78 may occur nominally at a displacement node. The waveguide 78 may screw or snap into the hand piece handle assembly 12 by a stud. Flat portions on the hub 76 may allow the assembly to be torqued to a required level. In one example embodiment, the hub 76 portion of the outer tubular sheath 56 is preferably constructed from plastic and the tubular elongated portion of the outer tubular sheath 56 is fabricated from stainless steel. Alternatively, the ultrasonic

transmission waveguide 78 may comprise polymeric material surrounding it to isolate it from outside contact.

[0113] In one example embodiment, the distal end of the ultrasonic transmission waveguide 78 may be coupled to the proximal end of the blade 66 by an internal threaded connection, preferably at or near an antinode. It is contemplated that the blade 66 may be attached to the ultrasonic transmission waveguide 78 by any suitable means, such as a welded joint or the like. Although the blade 66 may be detachable from the ultrasonic transmission waveguide 78, it is also contemplated that the single element end effector (*e.g.*, the blade 66) and the ultrasonic transmission waveguide 78 may be formed as a single unitary piece.

[0114] In one example embodiment, the trigger 32 is coupled to a linkage mechanism to translate the rotational motion of the trigger 32 in directions 33A and 33B to the linear motion of the reciprocating tubular actuating member 58 in corresponding directions 60A and 60B. The trigger 32 comprises a first set of flanges 98 with openings formed therein to receive a first yoke pin 92a. The first yoke pin 92a is also located through a set of openings formed at the distal end of the yoke 84. The trigger 32 also comprises a second set of flanges 96 to receive a first end 92a of a link 92. A trigger pin 90 is received in openings formed in the link 92 and the second set of flanges 96. The trigger pin 90 is received in the openings formed in the link 92 and the second set of flanges 96 and is adapted to couple to the first and second portions 12a, 12b of the handle assembly 12 to form a trigger pivot point for the trigger 32. A second end 92b of the link 92 is received in a slot 384 formed in a proximal end of the yoke 84 and is retained therein by a second yoke pin 94b. As the trigger 32 is pivotally rotated about the pivot point 190 formed by the trigger pin 90, the yoke translates horizontally along longitudinal axis “T” in a direction indicated by arrows 60A,B.

[0115] FIG. 8 illustrates one example embodiment of an ultrasonic surgical instrument 10. In the illustrated embodiment, a cross-sectional view of the ultrasonic transducer 16 is shown within a partial cutaway view of the handle assembly 12. One example embodiment of the ultrasonic surgical instrument 10 comprises the ultrasonic signal generator 20 coupled to the ultrasonic transducer 16, comprising a hand piece housing 99, and an ultrasonically actuatable single or multiple element end effector assembly 26. As previously discussed, the end effector assembly 26 comprises the ultrasonically actuatable blade 66 and the clamp arm 64. The ultrasonic transducer 16, which is known as a “Langevin stack”, generally includes a

transduction portion 100, a first resonator portion or end-bell 102, and a second resonator portion or fore-bell 104, and ancillary components. The total construction of these components is a resonator. The ultrasonic transducer 16 is preferably an integral number of one-half system wavelengths ($n\lambda/2$; where “n” is any positive integer; e.g., $n = 1, 2, 3 \dots$) in length as will be described in more detail later. An acoustic assembly 106 includes the ultrasonic transducer 16, a nose cone 108, a velocity transformer 118, and a surface 110.

[0116] In one example embodiment, the distal end of the end-bell 102 is connected to the proximal end of the transduction portion 100, and the proximal end of the fore-bell 104 is connected to the distal end of the transduction portion 100. The fore-bell 104 and the end-bell 102 have a length determined by a number of variables, including the thickness of the transduction portion 100, the density and modulus of elasticity of the material used to manufacture the end-bell 102 and the fore-bell 22, and the resonant frequency of the ultrasonic transducer 16. The fore-bell 104 may be tapered inwardly from its proximal end to its distal end to amplify the ultrasonic vibration amplitude as the velocity transformer 118, or alternately may have no amplification. A suitable vibrational frequency range may be about 20Hz to 32kHz and a well-suited vibrational frequency range may be about 30-10kHz. A suitable operational vibrational frequency may be approximately 55.5kHz, for example.

[0117] In one example embodiment, the piezoelectric elements 112 may be fabricated from any suitable material, such as, for example, lead zirconate-titanate, lead meta-niobate, lead titanate, barium titanate, or other piezoelectric ceramic material. Each of positive electrodes 114, negative electrodes 116, and the piezoelectric elements 112 has a bore extending through the center. The positive and negative electrodes 114 and 116 are electrically coupled to wires 120 and 122, respectively. The wires 120 and 122 are encased within the cable 22 and electrically connectable to the ultrasonic signal generator 20.

[0118] The ultrasonic transducer 16 of the acoustic assembly 106 converts the electrical signal from the ultrasonic signal generator 20 into mechanical energy that results in primarily a standing acoustic wave of longitudinal vibratory motion of the ultrasonic transducer 16 and the blade 66 portion of the end effector assembly 26 at ultrasonic frequencies. In another embodiment, the vibratory motion of the ultrasonic transducer may act in a different direction. For example, the vibratory motion may comprise a local longitudinal component of a more complicated motion of the tip of the elongated shaft assembly 14. A suitable generator is

available as model number GEN11, from Ethicon Endo-Surgery, Inc., Cincinnati, Ohio. When the acoustic assembly 106 is energized, a vibratory motion standing wave is generated through the acoustic assembly 106. The ultrasonic surgical instrument 10 is designed to operate at a resonance such that an acoustic standing wave pattern of predetermined amplitude is produced. The amplitude of the vibratory motion at any point along the acoustic assembly 106 depends upon the location along the acoustic assembly 106 at which the vibratory motion is measured. A minimum or zero crossing in the vibratory motion standing wave is generally referred to as a node (*i.e.*, where motion is minimal), and a local absolute value maximum or peak in the standing wave is generally referred to as an anti-node (*e.g.*, where local motion is maximal). The distance between an anti-node and its nearest node is one-quarter wavelength ($\lambda/4$).

[0119] The wires 120 and 122 transmit an electrical signal from the ultrasonic signal generator 20 to the positive electrodes 114 and the negative electrodes 116. The piezoelectric elements 112 are energized by the electrical signal supplied from the ultrasonic signal generator 20 in response to an actuator 224, such as a foot switch, for example, to produce an acoustic standing wave in the acoustic assembly 106. The electrical signal causes disturbances in the piezoelectric elements 112 in the form of repeated small displacements resulting in large alternating compression and tension forces within the material. The repeated small displacements cause the piezoelectric elements 112 to expand and contract in a continuous manner along the axis of the voltage gradient, producing longitudinal waves of ultrasonic energy. The ultrasonic energy is transmitted through the acoustic assembly 106 to the blade 66 portion of the end effector assembly 26 via a transmission component or an ultrasonic transmission waveguide portion 78 of the elongated shaft assembly 14.

[0120] In one example embodiment, in order for the acoustic assembly 106 to deliver energy to the blade 66 portion of the end effector assembly 26, all components of the acoustic assembly 106 must be acoustically coupled to the blade 66. The distal end of the ultrasonic transducer 16 may be acoustically coupled at the surface 110 to the proximal end of the ultrasonic transmission waveguide 78 by a threaded connection such as a stud 124.

[0121] In one example embodiment, the components of the acoustic assembly 106 are preferably acoustically tuned such that the length of any assembly is an integral number of one-half wavelengths ($n\lambda/2$), where the wavelength λ is the wavelength of a pre-selected or operating

longitudinal vibration drive frequency f_d of the acoustic assembly 106. It is also contemplated that the acoustic assembly 106 may incorporate any suitable arrangement of acoustic elements.

[0122] In one example embodiment, the blade 66 may have a length substantially equal to an integral multiple of one-half system wavelengths ($n\lambda/2$). A distal end of the blade 66 may be disposed near an antinode in order to provide the maximum longitudinal excursion of the distal end. When the transducer assembly is energized, the distal end of the blade 66 may be configured to move in the range of, for example, approximately 10 to 500 microns peak-to-peak, and preferably in the range of about 30 to 64 microns at a predetermined vibrational frequency of 55kHz, for example.

[0123] In one example embodiment, the blade 66 may be coupled to the ultrasonic transmission waveguide 78. The blade 66 and the ultrasonic transmission waveguide 78 as illustrated are formed as a single unit construction from a material suitable for transmission of ultrasonic energy. Examples of such materials include Ti6Al4V (an alloy of Titanium including Aluminum and Vanadium), Aluminum, Stainless Steel, or other suitable materials. Alternately, the blade 66 may be separable (and of differing composition) from the ultrasonic transmission waveguide 78, and coupled by, for example, a stud, weld, glue, quick connect, or other suitable known methods. The length of the ultrasonic transmission waveguide 78 may be substantially equal to an integral number of one-half wavelengths ($n\lambda/2$), for example. The ultrasonic transmission waveguide 78 may be preferably fabricated from a solid core shaft constructed out of material suitable to propagate ultrasonic energy efficiently, such as the titanium alloy discussed above (*i.e.*, Ti6Al4V) or any suitable aluminum alloy, or other alloys, for example.

[0124] In one example embodiment, the ultrasonic transmission waveguide 78 comprises a longitudinally projecting attachment post at a proximal end to couple to the surface 110 of the ultrasonic transmission waveguide 78 by a threaded connection such as the stud 124. The ultrasonic transmission waveguide 78 may include a plurality of stabilizing silicone rings or compliant supports 82 (FIG. 5) positioned at a plurality of nodes. The silicone rings 82 dampen undesirable vibration and isolate the ultrasonic energy from an outer protective sheath 80 (FIG. 5) assuring the flow of ultrasonic energy in a longitudinal direction to the distal end of the blade 66 with maximum efficiency.

[0125] FIG. 9 illustrates one example embodiment of the proximal rotation assembly 128. In the illustrated embodiment, the proximal rotation assembly 128 comprises the proximal

rotation knob 134 inserted over the cylindrical hub 135. The proximal rotation knob 134 comprises a plurality of radial projections 138 that are received in corresponding slots 130 formed on a proximal end of the cylindrical hub 135. The proximal rotation knob 134 defines an opening 142 to receive the distal end of the ultrasonic transducer 16. The radial projections 138 are formed of a soft polymeric material and define a diameter that is undersized relative to the outside diameter of the ultrasonic transducer 16 to create a friction interference fit when the distal end of the ultrasonic transducer 16. The polymeric radial projections 138 protrude radially into the opening 142 to form “gripper” ribs that firmly grip the exterior housing of the ultrasonic transducer 16. Therefore, the proximal rotation knob 134 securely grips the ultrasonic transducer 16.

[0126] The distal end of the cylindrical hub 135 comprises a circumferential lip 132 and a circumferential bearing surface 140. The circumferential lip engages a groove formed in the housing 12 and the circumferential bearing surface 140 engages the housing 12. Thus, the cylindrical hub 135 is mechanically retained within the two housing portions (not shown) of the housing 12. The circumferential lip 132 of the cylindrical hub 135 is located or “trapped” between the first and second housing portions 12a, 12b and is free to rotate in place within the groove. The circumferential bearing surface 140 bears against interior portions of the housing to assist proper rotation. Thus, the cylindrical hub 135 is free to rotate in place within the housing. The user engages the flutes 136 formed on the proximal rotation knob 134 with either the finger or the thumb to rotate the cylindrical hub 135 within the housing 12.

[0127] In one example embodiment, the cylindrical hub 135 may be formed of a durable plastic such as polycarbonate. In one example embodiment, the cylindrical hub 135 may be formed of a siliconized polycarbonate material. In one example embodiment, the proximal rotation knob 134 may be formed of pliable, resilient, flexible polymeric materials including Versaflex® TPE alloys made by GLS Corporation, for example. The proximal rotation knob 134 may be formed of elastomeric materials, thermoplastic rubber known as Santoprene®, other thermoplastic vulcanizates (TPVs), or elastomers, for example. The embodiments, however, are not limited in this context.

[0128] FIG. 10 illustrates one example embodiment of a surgical system 200 including a surgical instrument 210 having single element end effector 278. The system 200 may include a transducer assembly 216 coupled to the end effector 278 and a sheath 256 positioned around the

proximal portions of the end effector 278 as shown. The transducer assembly 216 and end effector 278 may operate in a manner similar to that of the transducer assembly 16 and end effector 18 described above to produce ultrasonic energy that may be transmitted to tissue via blade 226'

[0129] FIGS. 11-18C illustrate various embodiments of surgical instruments that utilize therapeutic and/or subtherapeutic electrical energy to treat and/or destroy tissue or provide feedback to the generators (*e.g.*, electrosurgical instruments). The embodiments of FIGS. 11-18C are adapted for use in a manual or hand-operated manner, although electrosurgical instruments may be utilized in robotic applications as well. FIG. 11 is a perspective view of one example embodiment of a surgical instrument system 300 comprising an electrical energy surgical instrument 310. The electrosurgical instrument 310 may comprise a proximal handle 312, a distal working end or end effector 326 and an introducer or elongated shaft 314 disposed in-between.

[0130] The electrosurgical system 300 can be configured to supply energy, such as electrical energy, ultrasonic energy, heat energy or any combination thereof, to the tissue of a patient either independently or simultaneously as described, for example, in connection with FIG. 1, for example. In one example embodiment, the electrosurgical system 300 includes a generator 320 in electrical communication with the electrosurgical instrument 310. The generator 320 is connected to electrosurgical instrument 310 via a suitable transmission medium such as a cable 322. In one example embodiment, the generator 320 is coupled to a controller, such as a control unit 325, for example. In various embodiments, the control unit 325 may be formed integrally with the generator 320 or may be provided as a separate circuit module or device electrically coupled to the generator 320 (shown in phantom to illustrate this option). Although in the presently disclosed embodiment, the generator 320 is shown separate from the electrosurgical instrument 310, in one example embodiment, the generator 320 (and/or the control unit 325) may be formed integrally with the electrosurgical instrument 310 to form a unitary electrosurgical system 300, where a battery located within the electrosurgical instrument 310 is the energy source and a circuit coupled to the battery produces the suitable electrical energy, ultrasonic energy, or heat energy. One such example is described herein below in connection with FIGS. 17-18C.

[0131] The generator 320 may comprise an input device 335 located on a front panel of the generator 320 console. The input device 335 may comprise any suitable device that generates signals suitable for programming the operation of the generator 320, such as a keyboard, or input port, for example. In one example embodiment, various electrodes in the first jaw 364A and the second jaw 364B may be coupled to the generator 320. The cable 322 may comprise multiple electrical conductors for the application of electrical energy to positive (+) and negative (-) electrodes of the electrosurgical instrument 310. The control unit 325 may be used to activate the generator 320, which may serve as an electrical source. In various embodiments, the generator 320 may comprise an RF source, an ultrasonic source, a direct current source, and/or any other suitable type of electrical energy source, for example, which may be activated independently or simultaneously

[0132] In various embodiments, the electrosurgical system 300 may comprise at least one supply conductor 331 and at least one return conductor 333, wherein current can be supplied to electrosurgical instrument 300 via the supply conductor 331 and wherein the current can flow back to the generator 320 via the return conductor 333. In various embodiments, the supply conductor 331 and the return conductor 333 may comprise insulated wires and/or any other suitable type of conductor. In certain embodiments, as described below, the supply conductor 331 and the return conductor 333 may be contained within and/or may comprise the cable 322 extending between, or at least partially between, the generator 320 and the end effector 326 of the electrosurgical instrument 310. In any event, the generator 320 can be configured to apply a sufficient voltage differential between the supply conductor 331 and the return conductor 333 such that sufficient current can be supplied to the end effector 110.

[0133] FIG. 12 is a side view of one example embodiment of the handle 312 of the surgical instrument 310. In FIG. 12, the handle 312 is shown with half of a first handle body 312A (see FIG. 11) removed to illustrate various components within second handle body 312B. The handle 312 may comprise a lever arm 321 (*e.g.*, a trigger) which may be pulled along a path 33. The lever arm 321 may be coupled to an axially moveable member 378 (FIGS. 13-16) disposed within elongated shaft 314 by a shuttle 384 operably engaged to an extension 398 of lever arm 321. The shuttle 384 may further be connected to a biasing device, such as a spring 388, which may also be connected to the second handle body 312B, to bias the shuttle 384 and thus the axially moveable member 378 in a proximal direction, thereby urging the jaws 364A and

364B to an open position as seen in FIG. 11. Also, referring to FIGS.11-12, a locking member 190 (see FIG. 12) may be moved by a locking switch 328 (see FIG. 11) between a locked position, where the shuttle 384 is substantially prevented from moving distally as illustrated, and an unlocked position, where the shuttle 384 may be allowed to freely move in the distal direction, toward the elongated shaft 314. The handle 312 can be any type of pistol-grip or other type of handle known in the art that is configured to carry actuator levers, triggers or sliders for actuating the first jaw 364A and the second jaw 364B. The elongated shaft 314 may have a cylindrical or rectangular cross-section, for example, and can comprise a thin-wall tubular sleeve that extends from handle 312. The elongated shaft 314 may include a bore extending therethrough for carrying actuator mechanisms, for example, the axially moveable member 378, for actuating the jaws and for carrying electrical leads for delivery of electrical energy to electrosurgical components of the end effector 326.

[0134] The end effector 326 may be adapted for capturing and transecting tissue and for the contemporaneously welding the captured tissue with controlled application of energy (*e.g.*, RF energy). The first jaw 364A and the second jaw 364B may close to thereby capture or engage tissue about a longitudinal axis “T” defined by the axially moveable member 378. The first jaw 364A and second jaw 364B may also apply compression to the tissue. In some embodiments, the elongated shaft 314, along with first jaw 364A and second jaw 364B, can be rotated a full 360° degrees, as shown by arrow 196 (see FIG. 11), relative to handle 312. For example, a rotation knob 348 may be rotatable about the longitudinal axis of the shaft 314 and may be coupled to the shaft 314 such that rotation of the knob 348 causes corresponding rotation of the shaft 314. The first jaw 364A and the second jaw 364B can remain openable and/or closeable while rotated.

[0135] FIG. 13 shows a perspective view of one example embodiment of the end effector 326 with the jaws 364A, 364B open, while FIG. 14 shows a perspective view of one example embodiment of the end effector 326 with the jaws 364A, 364B closed. As noted above, the end effector 326 may comprise the upper first jaw 364A and the lower second jaw 364B, which may be straight or curved. The first jaw 364A and the second jaw 364B may each comprise an elongated slot or channel 362A and 362B, respectively, disposed outwardly along their respective middle portions. Further, the first jaw 364A and second jaw 364B may each have tissue-gripping elements, such as teeth 363, disposed on the inner portions of first jaw 364A

and second jaw 364B. The first jaw 364A may comprise an upper first jaw body 200A with an upper first outward-facing surface 202A and an upper first energy delivery surface 365A. The second jaw 364B may comprise a lower second jaw body 200B with a lower second outward-facing surface 202B and a lower second energy delivery surface 365B. The first energy delivery surface 365A and the second energy delivery surface 365B may both extend in a “U” shape about the distal end of the end effector 326.

[0136] The lever arm 321 of the handle 312 (FIG. 12) may be adapted to actuate the axially moveable member 378, which may also function as a jaw-closing mechanism. For example, the axially moveable member 378 may be urged distally as the lever arm 321 is pulled proximally along the path 33 via the shuttle 384, as shown in FIG. 12 and discussed above. FIG. 15 is a perspective view of one example embodiment of the axially moveable member 378 of the surgical instrument 310. The axially moveable member 378 may comprise one or several pieces, but in any event, may be movable or translatable with respect to the elongated shaft 314 and/or the jaws 364A, 364B. Also, in at least one example embodiment, the axially moveable member 378 may be made of 17-4 precipitation hardened stainless steel. The distal end of axially moveable member 378 may comprise a flanged “I”-beam configured to slide within the channels 362A and 362B in jaws 364A and 364B. The axially moveable member 378 may slide within the channels 362A, 362B to open and close the first jaw 364A and the second jaw 364B. The distal end of the axially moveable member 378 may also comprise an upper flange or “c”-shaped portion 378A and a lower flange or “c”-shaped portion 378B. The flanges 378A and 378B respectively define inner cam surfaces 367A and 367B for engaging outward facing surfaces of the first jaw 364A and the second jaw 364B. The opening-closing of jaws 364A and 364B can apply very high compressive forces on tissue using cam mechanisms which may include movable “I-beam” axially moveable member 378 and the outward facing surfaces 369A, 369B of jaws 364A, 364B.

[0137] More specifically, referring now to FIGS. 13-15, collectively, the inner cam surfaces 367A and 367B of the distal end of axially moveable member 378 may be adapted to slidably engage the first outward-facing surface 369A and the second outward-facing surface 369B of the first jaw 364A and the second jaw 364B, respectively. The channel 362A within first jaw 364A and the channel 362B within the second jaw 364B may be sized and configured to accommodate the movement of the axially moveable member 378, which may comprise a tissue-

cutting element 371, for example, comprising a sharp distal edge. FIG. 14, for example, shows the distal end of the axially moveable member 378 advanced at least partially through channels 362A and 362B (FIG. 13). The advancement of the axially moveable member 378 may close the end effector 326 from the open configuration shown in FIG. 13. In the closed position shown by FIG. 14, the upper first jaw 364A and lower second jaw 364B define a gap or dimension D between the first energy delivery surface 365A and second energy delivery surface 365B of first jaw 364A and second jaw 364B, respectively. In various embodiments, dimension D can equal from about 0.0005" to about 0.040", for example, and in some embodiments, between about 0.001" to about 0.010", for example. Also, the edges of the first energy delivery surface 365A and the second energy delivery surface 365B may be rounded to prevent the dissection of tissue.

[0138] FIG. 16 is a section view of one example embodiment of the end effector 326 of the surgical instrument 310. The engagement, or tissue-contacting, surface 365B of the lower jaw 364B is adapted to deliver energy to tissue, at least in part, through a conductive-resistive matrix, such as a variable resistive positive temperature coefficient (PTC) body, as discussed in more detail below. At least one of the upper and lower jaws 364A, 364B may carry at least one electrode 373 configured to deliver the energy from the generator 320 to the captured tissue. The engagement, or tissue-contacting, surface 365A of upper jaw 364A may carry a similar conductive-resistive matrix (*i.e.*, a PTC material), or in some embodiments the surface may be a conductive electrode or an insulative layer, for example. Alternatively, the engagement surfaces of the jaws can carry any of the energy delivery components disclosed in U.S. Patent No. 6,773,409, filed Oct. 22, 2001, entitled ELECTROSURGICAL JAW STRUCTURE FOR CONTROLLED ENERGY DELIVERY, the entire disclosure of which is incorporated herein by reference.

[0139] The first energy delivery surface 365A and the second energy delivery surface 365B may each be in electrical communication with the generator 320. The first energy delivery surface 365A and the second energy delivery surface 365B may be configured to contact tissue and deliver electrosurgical energy to captured tissue which are adapted to seal or weld the tissue. The control unit 325 regulates the electrical energy delivered by electrical generator 320 which in turn delivers electrosurgical energy to the first energy delivery surface 365A and the second energy delivery surface 365B. The energy delivery may be initiated by an activation button 328 (FIG. 12) operably engaged with the lever arm 321 and in electrical communication with the

generator 320 via cable 322. In one example embodiment, the electrosurgical instrument 310 may be energized by the generator 320 by way of a foot switch 329 (FIG. 11). When actuated, the foot switch 329 triggers the generator 320 to deliver electrical energy to the end effector 326, for example. The control unit 325 may regulate the power generated by the generator 320 during activation. Although the foot switch 329 may be suitable in many circumstances, other suitable types of switches can be used.

[0140] As mentioned above, the electrosurgical energy delivered by electrical generator 320 and regulated, or otherwise controlled, by the control unit 325 may comprise radio frequency (RF) energy, or other suitable forms of electrical energy. Further, the opposing first and second energy delivery surfaces 365A and 365B may carry variable resistive positive temperature coefficient (PTC) bodies that are in electrical communication with the generator 320 and the control unit 325. Additional details regarding electrosurgical end effectors, jaw closing mechanisms, and electrosurgical energy-delivery surfaces are described in the following U.S. patents and published patent applications: U.S. Pat. Nos. 7,087,054; 7,083,619; 7,070,597; 7,041,102; 7,011,657; 6,929,644; 6,926,716; 6,913,579; 6,905,497; 6,802,843; 6,770,072; 6,656,177; 6,533,784; and 6,500,312; and U.S. Pat. App. Pub. Nos. 2010/0036370 and 2009/0076506, all of which are incorporated herein in their entirety by reference and made a part of this specification.

[0141] In one example embodiment, the generator 320 may be implemented as an electrosurgery unit (ESU) capable of supplying power sufficient to perform bipolar electrosurgery using radio frequency (RF) energy. In one example embodiment, the ESU can be a bipolar ERBE ICC 350 sold by ERBE USA, Inc. of Marietta, Georgia. In some embodiments, such as for bipolar electrosurgery applications, a surgical instrument having an active electrode and a return electrode can be utilized, wherein the active electrode and the return electrode can be positioned against, adjacent to and/or in electrical communication with, the tissue to be treated such that current can flow from the active electrode, through the positive temperature coefficient (PTC) bodies and to the return electrode through the tissue. Thus, in various embodiments, the electrosurgical system 300 may comprise a supply path and a return path, wherein the captured tissue being treated completes, or closes, the circuit. In one example embodiment, the generator 320 may be a monopolar RF ESU and the electrosurgical instrument 310 may comprise a monopolar end effector 326 in which one or more active electrodes are integrated. For such a

system, the generator 320 may require a return pad in intimate contact with the patient at a location remote from the operative site and/or other suitable return path. The return pad may be connected via a cable to the generator 320. In other embodiments, the operator 20 may provide subtherapeutic RF energy levels for purposes of evaluating tissue conditions and providing feedback in the electrosurgical system 300. Such feedback may be employed to control the therapeutic RF energy output of the electrosurgical instrument 310.

[0142] During operation of electrosurgical instrument 300, the user generally grasps tissue, supplies energy to the captured tissue to form a weld or a seal (*e.g.*, by actuating button 328 and/or pedal 216), and then drives a tissue-cutting element 371 at the distal end of the axially moveable member 378 through the captured tissue. According to various embodiments, the translation of the axial movement of the axially moveable member 378 may be paced, or otherwise controlled, to aid in driving the axially moveable member 378 at a suitable rate of travel. By controlling the rate of the travel, the likelihood that the captured tissue has been properly and functionally sealed prior to transection with the cutting element 371 is increased.

[0143] FIG. 17 is a perspective view of one example embodiment of a surgical instrument system comprising a cordless electrical energy surgical instrument 410. The electrosurgical system is similar to the electrosurgical system 300. The electrosurgical system can be configured to supply energy, such as electrical energy, ultrasonic energy, heat energy, or any combination thereof, to the tissue of a patient either independently or simultaneously as described in connection with FIGS. 1 and 11, for example. The electrosurgical instrument may utilize the end effector 326 and elongated shaft 314 described herein in conjunction with a cordless proximal handle 412. In one example embodiment, the handle 412 includes a generator circuit 420 (see FIG. 18A). The generator circuit 420 performs a function substantially similar to that of generator 320. In one example embodiment, the generator circuit 420 is coupled to a controller, such as a control circuit. In the illustrated embodiment, the control circuit is integrated into the generator circuit 420. In other embodiments, the control circuit may be separate from the generator circuit 420.

[0144] In one example embodiment, various electrodes in the end effector 326 (including jaws 364A, 364B thereof) may be coupled to the generator circuit 420. The control circuit may be used to activate the generator 420, which may serve as an electrical source. In various embodiments, the generator 420 may comprise an RF source, an ultrasonic source, a

direct current source, and/or any other suitable type of electrical energy source, for example. In one example embodiment, a button 328 may be provided to activate the generator circuit 420 to provide energy to the end effectors 326, 326.

[0145] FIG. 18A is a side view of one example embodiment of the handle 412 of the cordless surgical instrument 410. In FIG. 18A, the handle 412 is shown with half of a first handle body removed to illustrate various components within second handle body 434. The handle 412 may comprise a lever arm 424 (*e.g.*, a trigger) which may be pulled along a path 33 around a pivot point. The lever arm 424 may be coupled to an axially moveable member 478 disposed within elongated shaft 314 by a shuttle operably engaged to an extension of lever arm 424. In one example embodiment, the lever arm 424 defines a shepherd's hook shape comprising a distal member 424a and a proximal member 424b.

[0146] In one example embodiment, the cordless electrosurgical instrument comprises a battery 437. The battery 437 provides electrical energy to the generator circuit 420. The battery 437 may be any battery suitable for driving the generator circuit 420 at the desired energy levels. In one example embodiment, the battery 437 is a 100mAh, triple-cell Lithium Ion Polymer battery. The battery may be fully charged prior to use in a surgical procedure, and may hold a voltage of about 12.6V. The battery 437 may have two fuses fitted to the cordless electrosurgical instrument 410, arranged in line with each battery terminal. In one example embodiment, a charging port 439 is provided to connect the battery 437 to a DC current source (not shown).

[0147] The generator circuit 420 may be configured in any suitable manner. In some embodiments, the generator circuit comprises an RF drive and control circuit 440 and a controller circuit 482. FIG. 18B illustrates an RF drive and control circuit 440, according to one embodiment. FIG. 18B is a part schematic part block diagram illustrating the RF drive and control circuitry 440 used in this embodiment to generate and control the RF electrical energy supplied to the end effector 326. As will be explained in more detail below, in this embodiment, the drive circuitry 440 is a resonant mode RF amplifier comprising a parallel resonant network on the RF amplifier output and the control circuitry operates to control the operating frequency of the drive signal so that it is maintained at the resonant frequency of the drive circuit, which in turn controls the amount of power supplied to the end effector 326. The way that this is achieved will become apparent from the following description.

[0148] As shown in FIG. 18B, the RF drive and control circuit 440 comprises the above described battery 437 are arranged to supply, in this example, about 0V and about 12V rails. An input capacitor (C_{in}) 442 is connected between the 0V and the 12V for providing a low source impedance. A pair of FET switches 443-1 and 443-2 (both of which are N-channel in this embodiment to reduce power losses) is connected in series between the 0V rail and the 12V rail. FET gate drive circuitry 805 is provided that generates two drive signals - one for driving each of the two FETs 443. The FET gate drive circuitry 445 generates drive signals that causes the upper FET (443-1) to be on when the lower FET (443-2) is off and vice versa. This causes the node 447 to be alternately connected to the 12V rail (when the FET 443-1 is switched on) and the 0V rail (when the FET 443-2 is switched on). FIG. 18B also shows the internal parasitic diodes 448-1 and 448-2 of the corresponding FETs 443, which conduct during any periods that the FETs 443 are open.

[0149] As shown in FIG. 18B, the node 447 is connected to an inductor-inductor resonant circuit 450 formed by inductor L_s 452 and inductor L_m 454. The FET gate driving circuitry 445 is arranged to generate drive signals at a drive frequency (f_d) that opens and crosses the FET switches 443 at the resonant frequency of the parallel resonant circuit 450. As a result of the resonant characteristic of the resonant circuit 450, the square wave voltage at node 447 will cause a substantially sinusoidal current at the drive frequency (f_d) to flow within the resonant circuit 450. As illustrated in FIG. 18B, the inductor L_m 454 is the primary of a transformer 455, the secondary of which is formed by inductor L_{sec} 456. The inductor L_{sec} 456 of the transformer 455 secondary is connected to an inductor-capacitor-capacitor parallel resonant circuit 457 formed by inductor L_2 458, capacitor C_4 460, and capacitor C_2 462. The transformer 455 up-converts the drive voltage (V_d) across the inductor L_m 454 to the voltage that is applied to the output parallel resonant circuit 457. The load voltage (V_L) is output by the parallel resonant circuit 457 and is applied to the load (represented by the load resistance R_{load} 459 in FIG. 18B) corresponding to the impedance of the forceps' jaws and any tissue or vessel gripped by the end effector 326. As shown in FIG. 18B, a pair of DC blocking capacitors C_{bl} 480-1 and 480-2 is provided to prevent any DC signal being applied to the load 459.

[0150] In one embodiment, the transformer 455 may be implemented with a Core Diameter (mm), Wire Diameter (mm), and Gap between secondary windings in accordance with the following specifications:

[0151] Core Diameter, D (mm)

[0152] $D = 19.9 \times 10^{-3}$

[0153] Wire diameter, W (mm) for 22 AWG wire

[0154] $W = 7.366 \times 10^{-4}$

[0155] Gap between secondary windings, in gap = 0.125

[0156] $G = \text{gap}/25.4$

[0157] In this embodiment, the amount of electrical power supplied to the end effector 326 is controlled by varying the frequency of the switching signals used to switch the FETs 443. This works because the resonant circuit 450 acts as a frequency dependent (loss less) attenuator. The closer the drive signal is to the resonant frequency of the resonant circuit 450, the less the drive signal is attenuated. Similarly, as the frequency of the drive signal is moved away from the resonant frequency of the circuit 450, the more the drive signal is attenuated and so the power supplied to the load reduces. In this embodiment, the frequency of the switching signals generated by the FET gate drive circuitry 445 is controlled by a controller 481 based on a desired power to be delivered to the load 459 and measurements of the load voltage (V_L) and of the load current (I_L) obtained by conventional voltage sensing circuitry 483 and current sensing circuitry 485. The way that the controller 481 operates will be described in more detail below.

[0158] In one embodiment, the voltage sensing circuitry 483 and the current sensing circuitry 485 may be implemented with high bandwidth, high speed rail-to-rail amplifiers (e.g., LMH6643 by National Semiconductor). Such amplifiers, however, consume a relatively high current when they are operational. Accordingly, a power save circuit may be provided to reduce the supply voltage of the amplifiers when they are not being used in the voltage sensing circuitry 483 and the current sensing circuitry 485. In one-embodiment, a step-down regulator (e.g., LT3502 by Linear Technologies) may be employed by the power save circuit to reduce the supply voltage of the rail-to-rail amplifiers and thus extend the life of the battery 437.

[0159] FIG. 18C illustrates the main components of the controller 481, according to one embodiment. In the embodiment illustrated in FIG. 18C, the controller 481 is a microprocessor based controller and so most of the components illustrated in figure 16 are software based components. Nevertheless, a hardware based controller 481 may be used instead. As shown, the controller 481 includes synchronous I,Q sampling circuitry 491 that receives the sensed voltage and current signals from the sensing circuitry 483 and 485 and obtains corresponding samples

which are passed to a power, V_{rms} and I_{rms} calculation module 493. The calculation module 493 uses the received samples to calculate the RMS voltage and RMS current applied to the load 459 (FIG. 18B; end effector 326 and tissue/vessel gripped thereby) and from them the power that is presently being supplied to the load 459. The determined values are then passed to a frequency control module 495 and a medical device control module 497. The medical device control module 497 uses the values to determine the present impedance of the load 459 and based on this determined impedance and a pre-defined algorithm, determines what set point power (P_{set}) should be applied to the frequency control module 495. The medical device control module 497 is in turn controlled by signals received from a user input module 499 that receives inputs from the user (for example pressing buttons or activating the control levers 114, 110 on the handle 104) and also controls output devices (lights, a display, speaker or the like) on the handle 104 via a user output module 461.

[0160] The frequency control module 495 uses the values obtained from the calculation module 493 and the power set point (P_{set}) obtained from the medical device control module 497 and predefined system limits (to be explained below), to determine whether or not to increase or decrease the applied frequency. The result of this decision is then passed to a square wave generation module 463 which, in this embodiment, increments or decrements the frequency of a square wave signal that it generates by 1 kHz, depending on the received decision. As those skilled in the art will appreciate, in an alternative embodiment, the frequency control module 495 may determine not only whether to increase or decrease the frequency, but also the amount of frequency change required. In this case, the square wave generation module 463 would generate the corresponding square wave signal with the desired frequency shift. In this embodiment, the square wave signal generated by the square wave generation module 463 is output to the FET gate drive circuitry 445, which amplifies the signal and then applies it to the FET 443-1. The FET gate drive circuitry 445 also inverts the signal applied to the FET 443-1 and applies the inverted signal to the FET 443-2.

[0161] The electrosurgical instrument 410 may comprise additional features as discussed with respect to electrosurgical system 300. Those skilled in the art will recognize that electrosurgical instrument 410 may include a rotation knob 348, an elongated shaft 314, and an end effector 326. These elements function in a substantially similar manner to that discussed above with respect to the electrosurgical system 300. In one example embodiment, the cordless

electrosurgical instrument 410 may include visual indicators 435. The visual indicators 435 may provide a visual indication signal to an operator. In one example embodiment, the visual indication signal may alert an operator that the device is on, or that the device is applying energy to the end effector. Those skilled in the art will recognize that the visual indicators 435 may be configured to provide information on multiple states of the device.

[0162] Over the years a variety of minimally invasive robotic (or “telesurgical”) systems have been developed to increase surgical dexterity as well as to permit a surgeon to operate on a patient in an intuitive manner. Robotic surgical systems can be used with many different types of surgical instruments including, for example, ultrasonic or electrosurgical instruments, as described herein. Example robotic systems include those manufactured by Intuitive Surgical, Inc., of Sunnyvale, California, U.S.A. Such systems, as well as robotic systems from other manufacturers, are disclosed in the following U.S. Patents which are each herein incorporated by reference in their respective entirety: U.S. Pat. No. 5,792,135, entitled “Articulated Surgical Instrument For Performing Minimally Invasive Surgery With Enhanced Dexterity and Sensitivity”, U.S. Patent No. 6,231,565, entitled “Robotic Arm DLUs For Performing Surgical Tasks”, U.S. Patent No. 6,783,524, entitled “Robotic Surgical Tool With Ultrasound Cauterizing and Cutting Instrument”, U.S. Patent No. 6,364,888, entitled “Alignment of Master and Slave In a Minimally Invasive Surgical Apparatus”, U.S. Patent No. 7,524,320, entitled “Mechanical Actuator Interface System For Robotic Surgical Tools”, U.S. Patent No. 7,691,098, entitled Platform Link Wrist Mechanism”, U.S. Patent No. 7,806,891, entitled “Repositioning and Reorientation of Master/Slave Relationship in Minimally Invasive Telesurgery”, and U.S. Patent No. 7,824,401, entitled “Surgical Tool With Wristed Monopolar Electrosurgical End Effectors”. Many of such systems, however, have in the past been unable to generate the magnitude of forces required to effectively cut and fasten tissue.

[0163] FIGS. 19-46C illustrate example embodiments of robotic surgical systems. In some embodiments, the disclosed robotic surgical systems may utilize the ultrasonic or electrosurgical instruments described herein. Those skilled in the art will appreciate that the illustrated robotic surgical systems are not limited to only those instruments described herein, and may utilize any compatible surgical instruments. Those skilled in the art will further appreciate that while various embodiments described herein may be used with the described

robotic surgical systems, the disclosure is not so limited, and may be used with any compatible robotic surgical system.

[0164] FIGS. 19-25 illustrate the structure and operation of several example robotic surgical systems and components thereof. FIG. 19 shows a block diagram of an example robotic surgical system 1000. The system 1000 comprises at least one controller 508 and at least one arm cart 510. The arm cart 510 may be mechanically coupled to one or more robotic manipulators or arms, indicated by box 512. Each of the robotic arms 512 may comprise one or more surgical instruments 514 for performing various surgical tasks on a patient 504. Operation of the arm cart 510, including the arms 512 and instruments 514 may be directed by a clinician 502 from a controller 508. In some embodiments, a second controller 508', operated by a second clinician 502' may also direct operation of the arm cart 510 in conjunction with the first clinician 502'. For example, each of the clinicians 502, 502' may control different arms 512 of the cart or, in some cases, complete control of the arm cart 510 may be passed between the clinicians 502, 502'. In some embodiments, additional arm carts (not shown) may be utilized on the patient 504. These additional arm carts may be controlled by one or more of the controllers 508, 508'. The arm cart(s) 510 and controllers 508, 508' may be in communication with one another via a communications link 516, which may be any suitable type of wired or wireless communications link carrying any suitable type of signal (*e.g.*, electrical, optical, infrared, *etc.*) according to any suitable communications protocol. Example implementations of robotic surgical systems, such as the system 1000, are disclosed in U.S. Patent No. 7,524,320 which has been herein incorporated by reference. Thus, various details of such devices will not be described in detail herein beyond that which may be necessary to understand various embodiments of the claimed device.

[0165] FIG. 20 shows one example embodiment of a robotic arm cart 520. The robotic arm cart 520 is configured to actuate a plurality of surgical instruments or instruments, generally designated as 522 within a work envelope 519. Various robotic surgery systems and methods employing master controller and robotic arm cart arrangements are disclosed in U.S. Patent No. 6,132,368, entitled "Multi-Component Telepresence System and Method", the full disclosure of which is incorporated herein by reference. In various forms, the robotic arm cart 520 includes a base 524 from which, in the illustrated embodiment, three surgical instruments 522 are supported. In various forms, the surgical instruments 522 are each supported by a series of

manually articulatable linkages, generally referred to as set-up joints 526, and a robotic manipulator 528. These structures are herein illustrated with protective covers extending over much of the robotic linkage. These protective covers may be optional, and may be limited in size or entirely eliminated in some embodiments to minimize the inertia that is encountered by the servo mechanisms used to manipulate such devices, to limit the volume of moving components so as to avoid collisions, and to limit the overall weight of the cart 520. Cart 520 will generally have dimensions suitable for transporting the cart 520 between operating rooms. The cart 520 may be configured to typically fit through standard operating room doors and onto standard hospital elevators. In various forms, the cart 520 would preferably have a weight and include a wheel (or other transportation) system that allows the cart 520 to be positioned adjacent an operating table by a single attendant.

[0166] FIG. 21 shows one example embodiment of the robotic manipulator 528 of the robotic arm cart 520. In the example shown in FIG. 21, the robotic manipulators 528 may include a linkage 530 that constrains movement of the surgical instrument 522. In various embodiments, linkage 530 includes rigid links coupled together by rotational joints in a parallelogram arrangement so that the surgical instrument 522 rotates around a point in space 532, as more fully described in issued U.S. Pat. No. 5,817,084, the full disclosure of which is herein incorporated by reference. The parallelogram arrangement constrains rotation to pivoting about an axis 534a, sometimes called the pitch axis. The links supporting the parallelogram linkage are pivotally mounted to set-up joints 526 (FIG. 20) so that the surgical instrument 522 further rotates about an axis 534b, sometimes called the yaw axis. The pitch and yaw axes 534a, 534b intersect at the remote center 536, which is aligned along a shaft 538 of the surgical instrument 522. The surgical instrument 522 may have further degrees of driven freedom as supported by manipulator 540, including sliding motion of the surgical instrument 522 along the longitudinal instrument axis "LT-LT". As the surgical instrument 522 slides along the instrument axis LT-LT relative to manipulator 540 (arrow 534c), remote center 536 remains fixed relative to base 542 of manipulator 540. Hence, the entire manipulator 540 is generally moved to re-position remote center 536. Linkage 530 of manipulator 540 is driven by a series of motors 544. These motors 544 actively move linkage 530 in response to commands from a processor of a control system. As will be discussed in further detail below, motors 544 are also employed to manipulate the surgical instrument 522.

[0167] FIG. 22 shows one example embodiment of a robotic arm cart 520' having an alternative set-up joint structure. In this example embodiment, a surgical instrument 522 is supported by an alternative manipulator structure 528' between two tissue manipulation instruments. Those of ordinary skill in the art will appreciate that various embodiments of the claimed device may incorporate a wide variety of alternative robotic structures, including those described in U.S. Pat. No. 5,878,193, the full disclosure of which is incorporated herein by reference. Additionally, while the data communication between a robotic component and the processor of the robotic surgical system is primarily described herein with reference to communication between the surgical instrument 522 and the controller, it should be understood that similar communication may take place between circuitry of a manipulator, a set-up joint, an endoscope or other image capture device, or the like, and the processor of the robotic surgical system for component compatibility verification, component-type identification, component calibration (such as off-set or the like) communication, confirmation of coupling of the component to the robotic surgical system, or the like.

[0168] FIG. 23 shows one example embodiment of a controller 518 that may be used in conjunction with a robotic arm cart, such as the robotic arm carts 520, 520' depicted in FIGS. 20-22. The controller 518 generally includes master controllers (generally represented as 519 in FIG. 23) which are grasped by the clinician and manipulated in space while the clinician views the procedure via a stereo display 521. A surgeon feed back meter 515 may be viewed via the display 521 and provide the surgeon with a visual indication of the amount of force being applied to the cutting instrument or dynamic clamping member. The master controllers 519 generally comprise manual input devices which preferably move with multiple degrees of freedom, and which often further have a handle or trigger for actuating instruments (for example, for closing grasping saws, applying an electrical potential to an electrode, or the like).

[0169] FIG. 24 shows one example embodiment of an ultrasonic surgical instrument 522 adapted for use with a robotic surgical system. For example, the surgical instrument 522 may be coupled to one of the surgical manipulators 528, 528' described hereinabove. As can be seen in FIG. 24, the surgical instrument 522 comprises a surgical end effector 548 that comprises an ultrasonic blade 550 and clamp arm 552, which may be coupled to an elongated shaft assembly 554 that, in some embodiments, may comprise an articulation joint 556. FIG. 25 shows another example embodiment having an electrosurgical instrument 523 in place of the

ultrasonic surgical instrument 522. The surgical instrument 523 comprises a surgical end effector 548 that comprises closable jaws 551A, 551B having energy deliver surfaces 553A, 553B for engaging and providing electrical energy to tissue between the jaws 551A, 551B. A tissue cutting element or knife 555 may be positioned at the distal end of an axially movable member 557 that may extend through the elongated shaft assembly 554 to the instrument mounting portion 558. FIG. 26 shows one example embodiment of an instrument drive assembly 546 that may be coupled to one of the surgical manipulators 528, 528' to receive and control the surgical instruments 522, 523. The instrument drive assembly 546 may also be operatively coupled to the controller 518 to receive inputs from the clinician for controlling the instrument 522, 523. For example, actuation (*e.g.*, opening and closing) of the clamp arm 552, actuation (*e.g.*, opening and closing) of the jaws 551A, 551B, actuation of the ultrasonic blade 550, extension of the knife 555 and actuation of the energy delivery surfaces 553A, 553B, *etc.* may be controlled through the instrument drive assembly 546 based on inputs from the clinician provided through the controller 518. The surgical instrument 522 is operably coupled to the manipulator by an instrument mounting portion, generally designated as 558. The surgical instruments 522 further include an interface 560 which mechanically and electrically couples the instrument mounting portion 558 to the manipulator.

[0170] FIG. 27 shows another view of the instrument drive assembly of FIG. 26 including the ultrasonic surgical instrument 522. FIG. 28 shows another view of the instrument drive assembly of FIG. 26 including the electrosurgical instrument 523. The instrument mounting portion 558 includes an instrument mounting plate 562 that operably supports a plurality of (four are shown in FIG. 26) rotatable body portions, driven discs or elements 564, that each include a pair of pins 566 that extend from a surface of the driven element 564. One pin 566 is closer to an axis of rotation of each driven elements 564 than the other pin 566 on the same driven element 564, which helps to ensure positive angular alignment of the driven element 564. The driven elements 564 and pints 566 may be positioned on an adapter side 567 of the instrument mounting plate 562.

[0171] Interface 560 also includes an adaptor portion 568 that is configured to mountingly engage the mounting plate 562 as will be further discussed below. The adaptor portion 568 may include an array of electrical connecting pins 570, which may be coupled to a memory structure by a circuit board within the instrument mounting portion 558. While

interface 560 is described herein with reference to mechanical, electrical, and magnetic coupling elements, it should be understood that a wide variety of telemetry modalities might be used, including infrared, inductive coupling, or the like.

[0172] FIGS. 29-31 show additional views of the adapter portion 568 of the instrument drive assembly 546 of FIG. 26. The adapter portion 568 generally includes an instrument side 572 and a holder side 574 (FIG. 29). In various embodiments, a plurality of rotatable bodies 576 are mounted to a floating plate 578 which has a limited range of movement relative to the surrounding adaptor structure normal to the major surfaces of the adaptor 568. Axial movement of the floating plate 578 helps decouple the rotatable bodies 576 from the instrument mounting portion 558 when the levers 580 along the sides of the instrument mounting portion housing 582 are actuated (See FIGS. 24, 25) Other mechanisms/arrangements may be employed for releasably coupling the instrument mounting portion 558 to the adaptor 568. In at least one form, rotatable bodies 576 are resiliently mounted to floating plate 578 by resilient radial members, which extend into a circumferential indentation about the rotatable bodies 576. The rotatable bodies 576 can move axially relative to plate 578 by deflection of these resilient structures. When disposed in a first axial position (toward instrument side 572) the rotatable bodies 576 are free to rotate without angular limitation. However, as the rotatable bodies 576 move axially toward instrument side 572, tabs 584 (extending radially from the rotatable bodies 576) laterally engage detents on the floating plates so as to limit angular rotation of the rotatable bodies 576 about their axes. This limited rotation can be used to help drivingly engage the rotatable bodies 576 with drive pins 586 of a corresponding instrument holder portion 588 of the robotic system, as the drive pins 586 will push the rotatable bodies 576 into the limited rotation position until the pins 586 are aligned with (and slide into) openings 590.

[0173] Openings 590 on the instrument side 572 and openings 590 on the holder side 574 of rotatable bodies 576 are configured to accurately align the driven elements 564 (FIGS. 27, 28) of the instrument mounting portion 558 with the drive elements 592 of the instrument holder 588. As described above regarding inner and outer pins 566 of driven elements 564, the openings 590 are at differing distances from the axis of rotation on their respective rotatable bodies 576 so as to ensure that the alignment is not 33 degrees from its intended position. Additionally, each of the openings 590 may be slightly radially elongated so as to fittingly receive the pins 566 in the circumferential orientation. This allows the pins 566 to slide radially

within the openings 590 and accommodate some axial misalignment between the instrument 522, 523 and instrument holder 588, while minimizing any angular misalignment and backlash between the drive and driven elements. Openings 590 on the instrument side 572 may be offset by about 90 degrees from the openings 590 (shown in broken lines) on the holder side 574, as can be seen most clearly in FIG. 31.

[0174] Various embodiments may further include an array of electrical connector pins 570 located on holder side 574 of adaptor 568, and the instrument side 572 of the adaptor 568 may include slots 594 (FIG. 31) for receiving a pin array (not shown) from the instrument mounting portion 558. In addition to transmitting electrical signals between the surgical instrument 522, 523 and the instrument holder 588, at least some of these electrical connections may be coupled to an adaptor memory device 596 (FIG. 30) by a circuit board of the adaptor 568.

[0175] A detachable latch arrangement 598 may be employed to releasably affix the adaptor 568 to the instrument holder 588. As used herein, the term “instrument drive assembly” when used in the context of the robotic system, at least encompasses various embodiments of the adapter 568 and instrument holder 588 and which has been generally designated as 546 in FIG. 26. For example, as can be seen in FIG. 26, the instrument holder 588 may include a first latch pin arrangement 600 that is sized to be received in corresponding clevis slots 602 provided in the adaptor 568. In addition, the instrument holder 588 may further have second latch pins 604 that are sized to be retained in corresponding latch clevises 606 in the adaptor 568. *See* FIG. 30. In at least one form, a latch assembly 608 is movably supported on the adapter 568 and is biasable between a first latched position wherein the latch pins 600 are retained within their respective latch clevis 606 and an unlatched position wherein the second latch pins 604 may be into or removed from the latch clevises 606. A spring or springs (not shown) are employed to bias the latch assembly into the latched position. A lip on the instrument side 572 of adaptor 568 may slidably receive laterally extending tabs of instrument mounting housing 582.

[0176] As described the driven elements 564 may be aligned with the drive elements 592 of the instrument holder 588 such that rotational motion of the drive elements 592 causes corresponding rotational motion of the driven elements 564. The rotation of the drive elements 592 and driven elements 564 may be electronically controlled, for example, via the robotic arm 612, in response to instructions received from the clinician 502 via a controller 508. The

instrument mounting portion 558 may translate rotation of the driven elements 564 into motion of the surgical instrument 522, 523.

[0177] FIGS. 32-34 show one example embodiment of the instrument mounting portion 558 showing components for translating motion of the driven elements 564 into motion of the surgical instrument 522, 523. FIGS. 32-34 show the instrument mounting portion with a shaft 538 having a surgical end effector 610 at a distal end thereof. The end effector 610 may be any suitable type of end effector for performing a surgical task on a patient. For example, the end effector may be configured to provide RF and/or ultrasonic energy to tissue at a surgical site. The shaft 538 may be rotatably coupled to the instrument mounting portion 558 and secured by a top shaft holder 646 and a bottom shaft holder 648 at a coupler 650 of the shaft 538.

[0178] In one example embodiment, the instrument mounting portion 558 comprises a mechanism for translating rotation of the various driven elements 564 into rotation of the shaft 538, differential translation of members along the axis of the shaft (*e.g.*, for articulation), and reciprocating translation of one or more members along the axis of the shaft 538 (*e.g.*, for extending and retracting tissue cutting elements such as 555, overtubes and/or other components). In one example embodiment, the rotatable bodies 612 (*e.g.*, rotatable spools) are coupled to the driven elements 564. The rotatable bodies 612 may be formed integrally with the driven elements 564. In some embodiments, the rotatable bodies 612 may be formed separately from the driven elements 564 provided that the rotatable bodies 612 and the driven elements 564 are fixedly coupled such that driving the driven elements 564 causes rotation of the rotatable bodies 612. Each of the rotatable bodies 612 is coupled to a gear train or gear mechanism to provide shaft articulation and rotation and clamp jaw open/close and knife actuation.

[0179] In one example embodiment, the instrument mounting portion 558 comprises a mechanism for causing differential translation of two or more members along the axis of the shaft 538. In the example provided in FIGS. 32-34, this motion is used to manipulate articulation joint 556. In the illustrated embodiment, for example, the instrument mounting portion 558 comprises a rack and pinion gearing mechanism to provide the differential translation and thus the shaft articulation functionality. In one example embodiment, the rack and pinion gearing mechanism comprises a first pinion gear 614 coupled to a rotatable body 612 such that rotation of the corresponding driven element 564 causes the first pinion gear 614 to rotate. A bearing 616 is coupled to the rotatable body 612 and is provided between the driven

element 564 and the first pinion gear 614. The first pinion gear 614 is meshed to a first rack gear 618 to convert the rotational motion of the first pinion gear 614 into linear motion of the first rack gear 618 to control the articulation of the articulation section 556 of the shaft assembly 538 in a left direction 620L. The first rack gear 618 is attached to a first articulation band 622 (**FIG. 32**) such that linear motion of the first rack gear 618 in a distal direction causes the articulation section 556 of the shaft assembly 538 to articulate in the left direction 620L. A second pinion gear 626 is coupled to another rotatable body 612 such that rotation of the corresponding driven element 564 causes the second pinion gear 626 to rotate. A bearing 616 is coupled to the rotatable body 612 and is provided between the driven element 564 and the second pinion gear 626. The second pinion gear 626 is meshed to a second rack gear 628 to convert the rotational motion of the second pinion gear 626 into linear motion of the second rack gear 628 to control the articulation of the articulation section 556 in a right direction 620R. The second rack gear 628 is attached to a second articulation band 624 (**FIG. 33**) such that linear motion of the second rack gear 628 in a distal direction causes the articulation section 556 of the shaft assembly 538 to articulate in the right direction 620R. Additional bearings may be provided between the rotatable bodies and the corresponding gears. Any suitable bearings may be provided to support and stabilize the mounting and reduce rotary friction of shaft and gears, for example.

[0180] In one example embodiment, the instrument mounting portion 558 further comprises a mechanism for translating rotation of the driven elements 564 into rotational motion about the axis of the shaft 538. For example, the rotational motion may be rotation of the shaft 538 itself. In the illustrated embodiment, a first spiral worm gear 630 coupled to a rotatable body 612 and a second spiral worm gear 632 coupled to the shaft assembly 538. A bearing 616 (figure 17) is coupled to a rotatable body 612 and is provided between a driven element 564 and the first spiral worm gear 630. The first spiral worm gear 630 is meshed to the second spiral worm gear 632, which may be coupled to the shaft assembly 538 and/or to another component of the instrument 522, 523 for which longitudinal rotation is desired. Rotation may be caused in a clockwise (CW) and counter-clockwise (CCW) direction based on the rotational direction of the first and second spiral worm gears 630, 632. Accordingly, rotation of the first spiral worm gear 630 about a first axis is converted to rotation of the second spiral worm gear 632 about a second axis, which is orthogonal to the first axis. As shown in **FIGS. 32-33**, for example, a CW rotation of the second spiral worm gear 632 results in a CW rotation of the shaft assembly 538 in the

direction indicated by 634CW. A CCW rotation of the second spiral worm gear 632 results in a CCW rotation of the shaft assembly 538 in the direction indicated by 634CCW. Additional bearings may be provided between the rotatable bodies and the corresponding gears. Any suitable bearings may be provided to support and stabilize the mounting and reduce rotary friction of shaft and gears, for example.

[0181] In one example embodiment, the instrument mounting portion 558 comprises a mechanism for generating reciprocating translation of one or more members along the axis of the shaft 538. Such translation may be used, for example to drive a tissue cutting element, such as 555, drive an overtube for closure and/or articulation of the end effector 610, *etc.* In the illustrated embodiment, for example, a rack and pinion gearing mechanism may provide the reciprocating translation. A first gear 636 is coupled to a rotatable body 612 such that rotation of the corresponding driven element 564 causes the first gear 636 to rotate in a first direction. A second gear 638 is free to rotate about a post 640 formed in the instrument mounting plate 562. The first gear 636 is meshed to the second gear 638 such that the second gear 638 rotates in a direction that is opposite of the first gear 636. In one example embodiment, the second gear 638 is a pinion gear meshed to a rack gear 642, which moves in a linear direction. The rack gear 642 is coupled to a translating block 644, which may translate distally and proximally with the rack gear 642. The translation block 644 may be coupled to any suitable component of the shaft assembly 538 and/or the end effector 610 so as to provide reciprocating longitudinal motion. For example, the translation block 644 may be mechanically coupled to the tissue cutting element 555 of the RF surgical device 523. In some embodiments, the translation block 644 may be coupled to an overtube, or other component of the end effector 610 or shaft 538.

[0182] FIGS. 35-37 illustrate an alternate embodiment of the instrument mounting portion 558 showing an alternate example mechanism for translating rotation of the driven elements 564 into rotational motion about the axis of the shaft 538 and an alternate example mechanism for generating reciprocating translation of one or more members along the axis of the shaft 538. Referring now to the alternate rotational mechanism, a first spiral worm gear 652 is coupled to a second spiral worm gear 654, which is coupled to a third spiral worm gear 656. Such an arrangement may be provided for various reasons including maintaining compatibility with existing robotic systems 1000 and/or where space may be limited. The first spiral worm gear 652 is coupled to a rotatable body 612. The third spiral worm gear 656 is meshed with a

fourth spiral worm gear 658 coupled to the shaft assembly 538. A bearing 760 is coupled to a rotatable body 612 and is provided between a driven element 564 and the first spiral worm gear 738. Another bearing 760 is coupled to a rotatable body 612 and is provided between a driven element 564 and the third spiral worm gear 652. The third spiral worm gear 652 is meshed to the fourth spiral worm gear 658, which may be coupled to the shaft assembly 538 and/or to another component of the instrument 522, 523 for which longitudinal rotation is desired. Rotation may be caused in a CW and a CCW direction based on the rotational direction of the spiral worm gears 656, 658. Accordingly, rotation of the third spiral worm gear 656 about a first axis is converted to rotation of the fourth spiral worm gear 658 about a second axis, which is orthogonal to the first axis. As shown in Figures 36 and 37, for example, the fourth spiral worm gear 658 is coupled to the shaft 538, and a CW rotation of the fourth spiral worm gear 658 results in a CW rotation of the shaft assembly 538 in the direction indicated by 634CW. A CCW rotation of the fourth spiral worm gear 658 results in a CCW rotation of the shaft assembly 538 in the direction indicated by 634CCW. Additional bearings may be provided between the rotatable bodies and the corresponding gears. Any suitable bearings may be provided to support and stabilize the mounting and reduce rotary friction of shaft and gears, for example.

[0183] Referring now to the alternate example mechanism for generating reciprocating translation of one or more members along the axis of the shaft 538, the instrument mounting portion 558 comprises a rack and pinion gearing mechanism to provide reciprocating translation along the axis of the shaft 538 (*e.g.*, translation of a tissue cutting element 555 of the RF surgical device 523). In one example embodiment, a third pinion gear 660 is coupled to a rotatable body 612 such that rotation of the corresponding driven element 564 causes the third pinion gear 660 to rotate in a first direction. The third pinion gear 660 is meshed to a rack gear 662, which moves in a linear direction. The rack gear 662 is coupled to a translating block 664. The translating block 664 may be coupled to a component of the device 522, 523, such as, for example, the tissue cutting element 555 of the RF surgical device and/or an overtube or other component which is desired to be translated longitudinally.

[0184] FIGS. 38-42 illustrate an alternate embodiment of the instrument mounting portion 558 showing another alternate example mechanism for translating rotation of the driven elements 564 into rotational motion about the axis of the shaft 538. In FIGS. 38-42, the shaft 538 is coupled to the remainder of the mounting portion 558 via a coupler 676 and a bushing

678. A first gear 666 coupled to a rotatable body 612, a fixed post 668 comprising first and second openings 672, first and second rotatable pins 674 coupled to the shaft assembly, and a cable 670 (or rope). The cable is wrapped around the rotatable body 612. One end of the cable 670 is located through a top opening 672 of the fixed post 668 and fixedly coupled to a top rotatable pin 674. Another end of the cable 670 is located through a bottom opening 672 of the fixed post 668 and fixedly coupled to a bottom rotating pin 674. Such an arrangement is provided for various reasons including maintaining compatibility with existing robotic systems 1000 and/or where space may be limited. Accordingly, rotation of the rotatable body 612 causes the rotation about the shaft assembly 538 in a CW and a CCW direction based on the rotational direction of the rotatable body 612 (*e.g.*, rotation of the shaft 538 itself). Accordingly, rotation of the rotatable body 612 about a first axis is converted to rotation of the shaft assembly 538 about a second axis, which is orthogonal to the first axis. As shown in FIGS. 38-39, for example, a CW rotation of the rotatable body 612 results in a CW rotation of the shaft assembly 538 in the direction indicated by 634CW. A CCW rotation of the rotatable body 612 results in a CCW rotation of the shaft assembly 538 in the direction indicated by 634CCW. Additional bearings may be provided between the rotatable bodies and the corresponding gears. Any suitable bearings may be provided to support and stabilize the mounting and reduce rotary friction of shaft and gears, for example.

[0185] FIGS. 43-46A illustrate an alternate embodiment of the instrument mounting portion 558 showing an alternate example mechanism for differential translation of members along the axis of the shaft 538 (*e.g.*, for articulation). For example, as illustrated in FIGS. 43-46A, the instrument mounting portion 558 comprises a double cam mechanism 680 to provide the shaft articulation functionality. In one example embodiment, the double cam mechanism 680 comprises first and second cam portions 680A, 680B. First and second follower arms 682, 684 are pivotally coupled to corresponding pivot spools 686. As the rotatable body 612 coupled to the double cam mechanism 680 rotates, the first cam portion 680A acts on the first follower arm 682 and the second cam portion 680B acts on the second follower arm 684. As the cam mechanism 680 rotates the follower arms 682, 684 pivot about the pivot spools 686. The first follower arm 682 may be attached to a first member that is to be differentially translated (*e.g.*, the first articulation band 622). The second follower arm 684 is attached to a second member that is to be differentially translated (*e.g.*, the second articulation band 624). As the top cam

portion 680A acts on the first follower arm 682, the first and second members are differentially translated. In the example embodiment where the first and second members are the respective articulation bands 622 and 624, the shaft assembly 538 articulates in a left direction 620L. As the bottom cam portion 680B acts of the second follower arm 684, the shaft assembly 538 articulates in a right direction 620R. In some example embodiments, two separate bushings 688, 690 are mounted beneath the respective first and second follower arms 682, 684 to allow the rotation of the shaft without affecting the articulating positions of the first and second follower arms 682, 684. For articulation motion, these bushings reciprocate with the first and second follower arms 682, 684 without affecting the rotary position of the jaw 902. FIG. 46A shows the bushings 688, 690 and the dual cam assembly 680, including the first and second cam portions 680B, 680B, with the first and second follower arms 682, 684 removed to provide a more detailed and clearer view.

[0186] In various embodiments, the instrument mounting portion 558 may additionally comprise internal energy sources for driving electronics and provided desired ultrasonic and/or RF frequency signals to surgical tools. FIGS. 46B-46C illustrate one embodiment of a tool mounting portion 558' comprising internal power and energy sources. For example, surgical instruments (*e.g.*, instruments 522, 523) mounted utilizing the tool mounting portion 558' need not be wired to an external generator or other power source. Instead, the functionality of the various generators 20, 320 described herein may be implemented on board the mounting portion 558.

[0187] As illustrated in FIGS. 46B-46C, the instrument mounting portion 558' may comprise a distal portion 702. The distal portion 702 may comprise various mechanisms for coupling rotation of drive elements 612 to end effectors of the various surgical instruments 522, 523, for example, as described herein above. Proximal of the distal portion 702, the instrument mounting portion 558' comprises an internal direct current (DC) energy source and an internal drive and control circuit 704. In the illustrated embodiment, the energy source comprises a first and second battery 706, 708. In other respects, the tool mounting portion 558' is similar to the various embodiments of the tool mounting portion 558 described herein above.

[0188] The control circuit 704 may operate in a manner similar to that described above with respect to generators 20, 320. For example, when an ultrasonic instrument 522 is utilized, the control circuit 704 may provide an ultrasonic drive signal in a manner similar to that

described above with respect to generator 20. Also, for example, when an RF instrument 523 or ultrasonic instrument 522 capable of providing a therapeutic or non-therapeutic RF signal is used, the control circuit 704 may provide an RF drive signal, for example, as described herein above with respect to the module 23 of generator 20 and/or the generator 300. In some embodiments, the control circuit 704 may be configured in a manner similar to that of the control circuit 440 described herein above with respect to FIGS. 18B-18C.

[0189] Various embodiments described herein comprise an articulatable shaft. When using an articulatable shaft, components running through the shaft from the end effector must be flexible, so as to flex when the shaft articulates. In various embodiments, this can be accomplished by utilizing waveguides that have flexible portions. For example, FIG. 47 illustrates a schematic cross-sectional view of a portion of one example embodiment of an ultrasonic medical instrument 1500 comprising first, second and third waveguide portions. In FIG. 47, the hand piece and the sheath-articulation control knobs, *etc.* of the ultrasonic medical instrument 1500 are omitted for clarity. In the example embodiment shown in FIG. 47, the ultrasonic medical instrument 1500 comprises a medical ultrasonic waveguide 1502 for transmitting ultrasonic energy from a transducer (not shown in FIG. 47) to an ultrasonic blade 1544. The medical ultrasonic waveguide 1502 has a length and includes first, second and third waveguide portions 1504, 1506 and 1508. The second waveguide portion 1506 is located lengthwise between the first and third waveguide portions 1504 and 1508; the first waveguide portion 1504 is located proximal the second waveguide portion 1506; and the third waveguide portion 1508 is located distal the second waveguide portion 1506. The first and third waveguide portions 1504 and 1508 each have a larger transverse area and the second waveguide portion 1506 has a smaller transverse area. The second waveguide portion 1506 is more bendable than either of the first and third waveguide portions 1504 and 1508. It is further noted that ultrasonic vibration can be any one, or any combination, of longitudinal, transverse, and torsional vibration. In some embodiments, the section 1506 may have a circular cross-section (*e.g.*, a uniform cross-sectional radius).

[0190] In some embodiments the second bendable waveguide portion 1506 may not have a uniform cross-sectional radius. For example, FIG. 47A illustrates cross sections for two example embodiments of the waveguide portion 1506. The waveguide portion 1506' is illustrated in relation to two axes 1509, 1511, also shown in FIG. 47. In various embodiments,

the waveguide portion 1506' may have a cross sectional length along axis 1511 that is less than its cross sectional dimension along axis 1509. In some embodiments, the cross sectional length along the axis 1509 may be equal to the cross sectional length of the other waveguide portions 1504, 1506. The waveguide portion 1506' may be bendable along the axis 1509. Referring now to waveguide portion 1506'', its cross sectional lengths along the axis 1509, 1511 may be the same, providing the waveguide portion 1506'' with a greater range of directions for bending.

[0191] In some example embodiments, the medical ultrasonic waveguide 1502 is a monolithic (*e.g.*, the blade portion 1544 is integral to the waveguide 1502). Also, in some example embodiments, the medical ultrasonic waveguide 1502 includes first and second longitudinal vibration antinodes 1510 and 1512. The first waveguide portion 1504 may transition to the second waveguide portion 1506 proximate the first longitudinal vibration antinode 1510; and the second waveguide portion 1506 may transition to the third waveguide portion 1508 proximate the second longitudinal vibration antinode 1512. In some example embodiments, as illustrated by FIG. 47, the second waveguide portion 1506 is substantially $\frac{1}{2}$ of a resonant-longitudinal-wavelength long.

[0192] In one example application of the embodiment of FIG. 47, the ultrasonic medical instrument 1500 also includes a user-actuated articulated sheath 1514 which surrounds the medical ultrasonic waveguide 1502. In various example embodiments, the medical ultrasonic waveguide 1502 includes three (meaning at least three) longitudinal vibration nodes 1516 located, one each, on the first, second and third waveguide portions 1504, 1506 and 1508. It is noted that one or more additional longitudinal vibration nodes may, or may not, be present between any one or two of the three longitudinal vibration nodes 1516. In one modification, the sheath 1514 contacts (*e.g.*, directly contacts or indirectly contacts through at least one intervening member 1517 such as a silicone intervening member) the first, second and third waveguide portions 1504, 1506 and 1508 at a corresponding one of the three longitudinal vibration nodes 1516. In one example, the sheath 1514 includes a rigid first sheath portion 1518 contacting the first waveguide portion 1504 at the first longitudinal vibration node (the leftmost node 1516 of FIG. 47), a flexible second sheath portion 1520 contacting the second waveguide portion 1506 at the second longitudinal vibration node (the middle node 1516 of FIG. 47), and a rigid third sheath portion 1522 contacting the third waveguide portion 1508 at the third longitudinal vibration node (the rightmost node 1516 of FIG. 47). In some example

embodiments, the sheath 1514 has only two articulation positions (*e.g.*, straight and fully articulated). In other example embodiments, the sheath 1514 has a number of intermediate bent positions between a straight position and a fully articulated position depending on the number of energy efficient curves the waveguide 1502 can be formed to. In some example embodiments, such energy efficient curves minimize vibrational energy going into non-longitudinal vibrational modes.

[0193] FIG. 48 illustrates a schematic cross-sectional view of a portion of one example embodiment of an ultrasonic medical instrument 1524 comprising first and second waveguide portions 1530, 1532, where the first waveguide portion 1530 spans multiple $\frac{1}{2}$ resonant longitudinal wavelengths. In the example embodiment show in FIG. 48, a medical ultrasonic waveguide 1526 includes at least two longitudinal vibration nodes 1528 located on the first waveguide portion 1530. In one variation, a sheath 1534 contacts (*e.g.*, directly contacts or indirectly contacts through at least one intervening member 1536 such as a silicone intervening member) the first waveguide portion 1530 at the at-least-two longitudinal vibration nodes 1528. In some example embodiments, the sheath 1534 includes two rigid sheath portions 1538 and 1542 and one flexible sheath portion 1540, wherein the flexible sheath portion 1540 contacts the first waveguide portion 1530 at least one of the two longitudinal vibration nodes 1528, and wherein the flexible sheath portion 1540 is disposed between the two rigid sheath portions 1538 and 1542. In one example embodiment, the two rigid sheath portions 1538 and 1542 each contact the second waveguide portion 1532 at a corresponding one of the at-least-two longitudinal vibration nodes 1528.

[0194] Referring now to FIG. 47, the waveguide 1502 may comprise a blade portion 1544 adapted to contact and ultrasonically treat patient tissue. The blade portion 1544 may be disposed at a distal end of the waveguide 1502 (*e.g.*, distal of the third blade portion 1508 of the blade 1502). In one example embodiment, the surgical instrument 1500 may also comprise a user-actuated clamp arm 1546 pivotally attached to the sheath 1514, 1534 proximate the blade portion 1544, wherein the clamp arm 1546 and the medical ultrasonic waveguide 1502 at least in part define an ultrasonic surgical shears 1548. The tissue pad and clamping arm control mechanism has been omitted from FIG. 47. Referring again to FIG. 48, the medical ultrasonic waveguide 1526 may also comprise a blade portion 1545, similar to the blade portion 1544, and disposed at a distal end of the first waveguide portion 1532. The blade portion 1545 may also be

adapted to contact and ultrasonically treat patient tissue. The instrument 1524 of FIG. 48 may also comprise a clamp arm 1546, defining, with the blade portion 1545, an ultrasonic surgical shears 1548.

[0195] In various example embodiments, certain portions of the waveguides 1502, 1526 are substantially rigid. For example, first and third portions 1504 and 1508 of the waveguide 1502 may be substantially rigid. The first portion 1532 of the waveguide 1526 may be substantially rigid. Referring again to FIG. 47, the medical ultrasonic waveguide 1502 may include first and second neck portions 1550 and 1552 joining, respectively, the first and second waveguide portions 1504 and 1506 and the second and third waveguide portions 1506 and 1508. (A similar neck portion 1552 may join the first and second waveguide portions 1530, 1532 of the waveguide 1526.)

[0196] In one modification, the medical ultrasonic waveguide 1502 is substantially cylindrical from the first waveguide portion 1504 to the third waveguide portion 1508, wherein the first, second and third waveguide portions 1504, 1506 and 1508 each have a substantially constant diameter, and wherein the diameter of the second waveguide portion 1506 is smaller than the diameter of either of the first and third waveguide portions 1504 and 1508. In some example embodiments, the diameter of the second waveguide portion 1506 is between substantially one and two millimeters, and the diameter of the first and third waveguide portions is between substantially three and five millimeters. In one choice of materials, the medical ultrasonic waveguide 1502 consists essentially of a titanium alloy. In one modification, the medical ultrasonic waveguide 1502 includes first and second longitudinal vibration antinodes 1510 and 1512, and the first neck portion 1550 is disposed proximate the first longitudinal vibration antinode 1510 and the second neck portion 1552 is disposed proximate the second longitudinal vibration antinode 1512.

[0197] FIG. 49 illustrates a schematic cross-sectional view of one example embodiment of an ultrasonic waveguide 1554 for use with a medical instrument and comprising first and second waveguide portions, where a first waveguide portion 1556 is joined to a second waveguide portion 1558 by a dowel press fit. In the example illustrated in FIG. 49, the second waveguide portion 1558 is also coupled to a third waveguide portion 1560 by a dowel press fit. In various example embodiments, the second waveguide portion 1558 consists essentially of titanium or nitinol. In the same or a different illustration, the length of the second waveguide

portion 1558 is less than $\frac{1}{2}$ wavelength (a wavelength being the length of a resonant-longitudinal-wavelength of the medical ultrasonic waveguide which depends essentially on the material of the waveguide and the frequency at which it is run) and in one example is less than $\frac{1}{8}$ wave.

[0198] FIG. 50 illustrates a schematic cross-sectional view of one example embodiment of an ultrasonic waveguide 1564 for use with a medical instrument. Like the waveguide 1554, the waveguide 1564 is not a monolithic waveguide. The waveguide 1564 may comprise first and second waveguide portions 1564, 1566, where the first waveguide portion 1564 is joined to the second waveguide 1566 portion by a ball-and-socket type attachment. The second waveguide portion 1566 may also be joined to a third waveguide portion 1568 in any suitable manner. In the example of FIG. 50, the second waveguide portion 1566 is joined to the third waveguide portion 1568 via a dowel press fit. Other attachments between waveguide portions are left to those skilled in the art.

[0199] FIG. 51 illustrates a schematic cross-sectional view of a portion of another embodiment of an ultrasonic medical instrument 1570 comprising a medical ultrasonic waveguide 1572 having a length and including a proximal waveguide portion 1574 and a distal waveguide portion 1576. The proximal waveguide portion 1574 has a larger transverse area and the distal waveguide portion 1576 has a smaller transverse area. The distal waveguide portion 1576 bends more easily than does the proximal waveguide portion 1574. The distal waveguide portion 1576 includes a distal end portion 1580 adapted to contact and ultrasonically treat patient tissue. In various example embodiments, the additional $\frac{1}{2}$ wave needed to neck up and create the larger diameter end effector of the embodiment of FIG. 47 is eliminated making it possible to place the articulation joint closer to the distal end of the ultrasonic medical instrument 1570. The embodiments, applications, *etc.* shown in Figures 47-50 are equally applicable (without the presence of the third waveguide portion) to the embodiment of FIG. 51.

[0200] FIG. 52 illustrates one embodiment of an instrument mounting portion 1000 for use with a robotic surgical system, such as the system 300, comprising a magnetic element-driven control mechanism. The instrument mounting portion 1000 may interface with a robotic surgical system, for example, in a manner similar to that described above with respect to the instrument mounting portion 558. The instrument mounting portion 1000 may comprise a housing 1001. A shaft 1003 may extend distally from the housing 1001. A distal portion of the

shaft 1003 may comprise an end effector for treating tissue. The end effector (not shown) may be similar to any of the end effectors described herein including, for example, the end effector assembly 26, end effector 18, end effector 278, end effector 326, end effector 110, *etc.*

[0201] The housing 1001 may contain one or more magnetic elements 1002, 1004, 1006, 1008, 1010, 1012. The magnetic elements, for example, may be magnetic elements configured to generate linear motion such as, for example, solenoids, voice coil motors, *etc.* Each of the magnetic elements 1002, 1004, 1006, 1008, 1010, 1012 may be fixedly secured to an inner wall or other portion of the housing 1001 or to another component within the housing 1001. Each of the magnetic elements 1002, 1004, 1006, 1008, 1010, 1012 may comprise a plunger or piston 1015 that may alternately extend from and be retracted within the respective magnetic elements based on whether the elements are energized.

[0202] As illustrated in FIG. 52, the plungers 1015 of the various magnetic elements 1002, 1004, 1006, 1008 are fixedly secured to an inner wall of the housing 1001. Accordingly, upon energizing and de-energizing, the respective elements may be pulled towards the inner wall and pushed away from the inner wall. Compression springs 1014 may be positioned around the plungers 1015 to resist motion of the plungers 1015. For example, upon energizing, the respective plungers 1015 may be forced out of the respective magnetic elements. The compression springs 1014 may resist this motion such that when the respective magnetic elements are de-energized, the plungers are pushed (by the springs 1014) back into the respective magnetic elements. Also, in some embodiments, the positioning of the springs 1014 and operation of the plungers 1015 are reversed. For example, the plungers 1015 may be pulled within the respective elements on energizing. Springs 1014 may resist the motion of the plungers 1015 and pull the plungers back to an extended position upon de-energizing.

[0203] Opposite the compression spring 1014 and plunger 1015, each magnetic element may be coupled to respective control cables 1016, 1018, 1020, 1022, 1024, 1026. In FIG. 52, element 1002 is coupled to cable 1016; element 1004 is coupled to cable 1018; element 1006 is coupled to cable 1020, element 1008 is coupled to cable 1022; element 1010 is coupled to cable 1024 and element 1012 is coupled to cable 1026. The control cables may extend distally through the shaft to the distal portion of the shaft 1003, an end effector (not shown), *etc.* In some embodiments, the installation of the magnetic elements 1002, 1004, 1006, 1008, 1010, 1012 may be reversed. For example, the respective elements may be fixedly coupled to the housing 1001

or other mechanism while the respective plungers 1015 are coupled to control cables 1016, 1018, 1020, 1022, 1024, 1026.

[0204] Distal and proximal translation of the respective cables may cause various mechanical motion in the instrument. For example, differential motion of two or more cables and/or distal and proximal translation of a single cable or cables may bring about articulation of an end effector, a distal cable portion, *etc.*, as described herein above. For example, some or all of the control cables may operate in a manner similar to the articulation bands 622, 624 described above. Also, for example, some or all of the control cables may be utilized to actuate a jaw or clamp arm member, as described herein above. Additional examples of articulation, end effector and other instrument portions that may be controlled by the control cables are provided in concurrently filed and commonly owned U.S. Patent Application Serial Nos. incorporated herein by reference at the section entitled CROSS-REFERENCE TO RELATED APPLICATIONS.

[0205] Each magnetic element 1002, 1004, 1006, 1008, 1010, 1012 may be individually energizable. In some embodiments, when a magnetic element is energized, it is pulled towards the inner wall of the housing 1001, compressing its corresponding compression spring 1014 and pulling its corresponding cable proximally through the shaft 1003. For example, energizing the respective elements may pull the respective plungers 1015 into the elements. When the magnetic element is de-energized, the force pulling it towards the inner wall of the housing 1001 may be relaxed, allowing slack in the corresponding cable. Also, for example, respective compression springs 1014 may push the respective elements away from the inner wall of the housing 1001.

[0206] The magnetic elements 1002, 1004, 1006, 1008, 1010, 1012 may be actuated by rotatable bodies 1005, 1007. The rotatable bodies 1005, 1007 may operate in a manner similar to that described above with respect to the rotatable bodies 612. For example, the rotatable bodies 1005, 1007 may be driven, for example, by the drive pins under the control of the robotic surgical system, such as the drive pins 586 shown in FIG. 26 and described herein above. The respective rotatable bodies 1005, 1007 may be coupled to a mounting member 1028. Each mounting member 1028 may be coupled to one or more actuation members 1030, 1032, 1034, 1036, 1038, 1040 extending from respective mounting members 1028 to switches 1042, 1044, 1046, 1048, 1050, 1052 of the respective magnetic elements. Rotation of the rotatable bodies 1005, 1007 may alternately place distal and proximal forces on the actuation members 1030,

1032, 1034, 1036, 1038, 1040 causing the switches on the respective magnetic elements to transition between “on” (element is energized) and “off” (element is not energized) positions.

[0207] FIGS. 53A-G illustrate one embodiment of the rotatable body 1005 and magnetic elements 1002, 1004, 1006 of the instrument mounting portion 1000, with the rotatable body 1005 at various angular positions to energize and/or de-energize combinations of the magnetic elements 1002, 1004, 1006. In FIG. 53A, the rotatable body 1005 is shown rotated counter clockwise such that actuation members 1030, 1032, 1034 are all pulled proximally, pulling switches 1042, 1044, 1046 proximally, and de-energizing elements 1002, 1004, 1006. In FIG. 53B, the rotatable body 1005 is rotated slightly clockwise from the position shown in FIG. 53A. Actuation member 1034 is pushed distally to transition switch 1042 and energize element 1002. Elements 1004 and 1006 are still de-energized. In FIG. 53C, the rotatable body 1005 is rotated further clockwise. Actuation member 1032 is not also pushed distally to transition switch 1042 and energy element 1004. Element 1006 is still de-energized. In FIG. 53D, further clockwise rotation of the rotatable body 1005 pushes control member 1030 distally to transition switch 1046. Accordingly, all of the elements 1002, 1004, 1006 are energized. In FIG. 53E, further clockwise rotation of the rotatable body 1005 begins to pull the actuation member 1034 proximally, transitioning switch 1042 to de-energize the element 1002. Elements 1004, 1006 are still energized. In FIG. 53F, further clockwise rotation of the rotatable body 1005 begins to pull the actuation member 1032 proximally, transitioning switch 1044 to de-energize element 1004. Element 1006 is still energized. In FIG. 53G, further clockwise rotation of the rotatable body 1005 pulls the control member 1030 distally to transition switch 1046 and de-energize the element 1006. All elements 1002, 1004, 1006 are de-energized in FIG. 53G.

[0208] It will be appreciated that the examples provided in FIGS. 53A-G are merely examples of how the rotatable body 1005 may serve to energize and de-energize the various elements 1002, 1004, 1006. In some embodiments, the rotatable body 1007 may operate in a similar manner to actuate the elements 1008, 1010, 1012. Also, in some embodiments, the positions of the switches 1042, 1044, 1046 illustrated in FIGS. 53A-G may be reversed, this reversing the described state of each element 1002, 1004, 1006 at each position.

[0209] FIG. 54 illustrates another embodiment of an instrument mounting portion 1060 for use with a robotic surgical system, such as the system 500, comprising a magnetic element-driven control mechanism. In FIG. 53, actuation of magnetic elements 1062, 1064, 1066, 1068

may be initiated by an electronic signal provided to the respective magnetic elements 1062, 1064, 1066, 1068, for example, via a control line of the robotic surgical system 500. In some embodiments, control signals may be provided to the magnetic elements via compression springs 1063. Magnetic elements 1062, 1064, 1066, 1068 may operate in a manner similar to the magnetic elements of the instrument mounting portion 1000 described above. For example, when energized, the magnetic elements 1062, 1064, 1066, 1068 may retract respective plungers 1065 within the elements 1062, 1064, 1066, 1068, thus pulling the elements towards the interior wall of the housing 1001, compressing compression springs 1063 and pulling respective cables 1070, 1072, 1074, 1076 proximally. The elements 1062, 1064, 1066, 1068, however, may be configured and/or mounted in any suitable configuration, however.

[0210] In some embodiments, the magnetic elements 1062, 1064, 1066, 1068 may utilize compression springs 1063 to exercise increased control over the positions of the respective cables 1070, 1072, 1074, 1076. For example, as described herein, the magnetic elements 1062, 1064, 1066, 1068 may be driven by electric signals provided by the robotic surgical system 500. The signal, for example, may provide an electric current to a coil or other electromagnetic element that may, in turn, exert an electromagnetic force on the respective plungers 1065. The magnitude of the current may control the magnitude of the force exerted on the plungers 1065. It will be appreciated that the compression (or displacement) of the springs 1063 may be proportional to the force provided by the respective magnetic elements. Accordingly, the displacement of the plungers 1063 and, therefore, the distal and/or proximal position of the control cables 1076, 1074, 1072, 1070 may be controlled based on the magnitude of the current (or other control signal) provided to the respective magnetic elements.

[0211] In the configuration illustrated in FIG. 54, cables 1070, 1072, 1074 extend distally through the shaft 1003, for example, to control an articulation joint, end effector, *etc.* Control cable 1076 may be routed by a pulley 1078 and may be positioned around a proximal portion 1080 of the shaft. When the magnetic element 1068 is energized, the cable 1076 may be pulled proximally. When routed by the pulley, this may unwrap the cable 1076 from the proximal portion 1080 of the shaft, causing the shaft 1003 to rotate in the direction indicated by arrow 1082.

[0212] FIG. 55 illustrates yet another embodiment of an instrument mounting portion 1084 for use with a robotic surgical system 500 comprising a magnetic element-driven control

mechanism and a spool-driven control mechanism. In FIG. 55, solenoids 1090, 1092 may be coupled to control cables 1096 and 1098 and may operate in a manner similar to that described above with respect to elements 1062, 1064, 1066. Additionally, rotatable bodies 1086, 1088 may define spools for receiving cables 1094, 1099 such that rotation of the rotatable bodies 1086, 1088 causes winding and unwinding of the respective control cables 1096, 1099, resulting in proximal and distal translation of the same.

[0213] FIGS. 56-57 illustrate one embodiment of an instrument mounting portion 1100 for use with a robotic surgical system, such as the system 500, comprising a translatable cable 1110 driven by a pair of rotatable bodies 1102, 1104. An elastic band 1112 may be coupled to fixed positions on each of the rotatable bodies 1102, 1104. For example, the elastic band 1112 may be coupled to respective pegs 1106, 1108 mounted on the rotatable bodies 1104, 1102. The elastic band 1112 may be made from any suitable material including, for example rubber or any other suitable elastomer. The translatable cable 1110 may be coupled to the elastic band 1112. As the rotatable bodies 1104 rotate, the pegs 1106, 1108 may translate proximally and distally and also from top to bottom across the housing 1001 of the instrument mounting portion 1100. The elastic nature of the band 1112 may cancel the up and down motion of the pegs 1106, 1108 while the distal and proximal motion may be translated to the cable 1110. Thus, the cable 1110 may also translate proximally and distally in the shaft 1003.

[0214] FIG. 58 illustrates another embodiment of an instrument mounting portion 1114 for use with a robotic surgical system, such as the system of 500, comprising a translatable cable 1124 driven by a pair of rotatable bodies 1116, 1118. The cable 1124 is coupled to an interior wall of the housing 1001 at a mounting point 1124. Posts or pulleys 1120, 1122 are positioned on respective rotatable bodies 1116, 1118. The cable 1124 is routed around the pulleys 1120, 1122 and extends distally through the shaft 1003. As the rotatable bodies 1116, 1118 rotate, the pulleys 1120, 1122 translate distally and proximally as well as up and down as shown in FIG. 58. This translation may cause the cable 1124 to translate proximally and distally within the shaft 1003. For example, in the embodiment shown in FIG. 58, up and down translation of the pulleys 1120, 1122 may alternately create tension and slack in the cable 1124, accentuating its distal and proximal translation.

[0215] FIGS. 59-62 illustrate one embodiment of an articulation mechanism 1130 that may be utilized by manual and/or robotic surgical instruments to articulate an end effector. In

various embodiments, the mechanism 1130 may be utilized with an ultrasonic instrument, for example, as illustrated in FIG. 59. In FIG. 59, a proximal end (not shown) of a waveguide 1136 may be coupled to an ultrasonic transducer (not shown) as the waveguide 78 is coupled to the ultrasonic transducer 16 described above. The waveguide 1136 may also comprise a bendable portion 1138 similar to the bendable portions including 1506 described above with respect to FIGS. 47-51. The bendable portion 1138 may be positioned at an articulation joint within a shaft of the instrument, for example, similar to the articulation joint 556 described herein above.

[0216] The mechanism 1130 may comprise first and second helical cables 1132, 1134. The cables 1132, 1134, for example, may be constructed from a helically wound wire. The helical cables 1132, 1134 may be coupled to a distal plate 1140. The distal plate 1140 may be coupled to an end effector and/or distal shaft portion of the instrument. In some embodiments, the distal plate 1140 is coupled to the waveguide 1136, as shown in FIG. 59. For example, the distal plate 1140 may be coupled to a node of the waveguide 1136. The helical cables 1132, 1134 may extend proximally where they may engage with a gear 1141. Respective plates 1142 may be positioned around the gear 1141 such that the cable 1132 passes between the gear 1141 and the plate 1142 and cable 1134 passes between the gear and the plate 1144. Teeth of the gear 1141 may interface with the helical cables 1132, 1134 such that clockwise rotation of the gear causes proximal translation of the cable 1134 and distal translation of the cable 1132. This, in turn, may pull the plate 1140 proximally towards the cable 1134, causing articulation. Similarly, counter-clockwise rotation of the gear 1141 may pull the cable 1132 proximally and push the cable 1134 distally. This may cause the plate 1140 to pivot towards the cable 1132 causing articulation opposite that when the gear 1141 rotates clockwise.

[0217] Rotation of the gear 1141 may be brought about in any suitable manner. For example, FIGS. 60 and 61 illustrate the mechanism 1130 for use in a hand held or manual instrument 1148. Referring to FIG. 61, a manual instrument 1148 may comprise an articulation lever 1152. The articulation lever 1152 may be coupled to the gear 1141, as illustrated in FIG. 60, such that rotation of the articulation lever 1152 causes corresponding articulation of the gear 1151. Rotation of the gear 1141, and resulting differential translation of the helical cables 1132, 1134 may cause articulation of the end effector 1154 about an articulation joint 1146. FIG. 62 illustrates one embodiment of an instrument mounting portion 1156 comprising the mechanism

1130. For example, the gear 1141 may be coupled to a rotatable body 612. Cables 1132, 1134 may be routed to extend distally through the shaft 1003.

[0218] FIGS. 63A-B illustrate one embodiment of an articulation mechanism 1150 that may be utilized with any suitable control mechanism, including those described above with respect to FIGS. 52-58. The mechanism 1150 is shown in the context of an end effector 1152 and a shaft portion 1154 separated by a flexible articulation joint 1170. The end effector 1152 may be any suitable type of ultrasonic, electrosurgical or combined end effector, as described herein. A plate 1156 may be positioned distally from the articulation joint 1170 and may be coupled to a plurality of control cables 1158, 1160, 1162, 1164, 1166, 1168. In some embodiments, the control cables 1158, 1160, 1162, 1164, 1166, 1168 may be coupled to and/or the distal ends of control cables 1016, 1018, 1020, 1022, 1024, 1026 described herein above. In some embodiments, the plate defines an opening 1172 for receiving wires, waveguides, *etc.* for operation of the end effector 1152.

[0219] The end effector 1152 and shaft portion 1154 may be articulated relative to one another by differential translation of the control cables 1158, 1160, 1162, 1164, 1166, 1168. For example, proximal translation of a control cable may cause the portion of the plate 1156 coupled to the control cable to be pulled proximally. The number and position of control cables 1158, 1160, 1162, 1164, 1166, 1168 that are pulled proximally may determine the direction in which the end effector 1152 is articulated. Although six cables are illustrated in FIGS. 63A-B, it will be appreciated that any suitable number of cables may be used. For example, FIGS. 64-65 illustrate embodiments of the plate 1156 configured for use with three and four cables, respectively. For example, the plate 1156, as illustrated in FIG. 64 comprises mounting points 1174 for three cables while the plate 1156, as illustrated in FIG. 65, comprises mounting points for four cables.

[0220] FIGS. 66-67 illustrate one embodiment of a shaft portion 1180 of a surgical instrument utilizing an articulation mechanism similar to the mechanism 1130 described herein above. The shaft portion 1180 may comprise four articulation control cables 1190, 1192, 1194, 1196. The articulation control cables 1190, 1192, 1194, 1196 may be coupled to either an end effector 1182 or a distal shaft portion and may extend proximally to a handle and/or robotic instrument mounting portion. The cables 1190, 1192, 1194, 1196 may be distally and proximally

translated in any suitable manner including, for example, utilizing the mechanisms described herein above with respect to FIGS. 52-58 and 60-61.

[0221] In various embodiments, the shaft portion 1180 may comprise an end effector 1182 comprising an ultrasonic blade 1197. The ultrasonic blade 1197 may be coupled to a distally mounted ultrasonic transducer assembly 1184. An articulation joint 1186 may be coupled to the end effector 1182 to the shaft 1188. The articulation joint 1186 may be made from any type of flexible material and/or may comprise a hinge (not shown). The articulation control cables 1190, 1192, 1194, 1196 may be coupled to any portion of the shaft portion 1180 distal of all or a part of the articulation joint 1186. For example, a plate 1198 (similar to the plate 1156 of FIG. 65) may be mounted as illustrated and may be coupled to the respective control cables 1190, 1192, 1194, 1196. A clamp arm control cable 1199 may be positioned to manipulate a clamp arm 1195 that may be actuated in a manner similar to that described above with respect to FIGS. 2-7.

[0222] It will be appreciated that proximal translation of the respective cables 1190, 1192, 1194, 1196 may articulate the end effector 1182 in different directions. For example, proximal translation of the cable 1194 may pull the end effector 1182 towards the cable 1194, as illustrated in FIG. 67. Likewise, proximal translation of any of the other cables 1190, 1192, 1196 may pull the end effector 1182 towards the proximally translated cable. FIG. 66 illustrates four example directions of articulation with the UP direction corresponding to proximal translation of the cable 1194, the DOWN direction corresponding to proximal translation of the cable 1190, the LEFT direction corresponding to proximal translation of the cable 1196 and the RIGHT direction corresponding to proximal translation of the cable 1192. In various embodiments, the end effector 1182 of FIGS. 66-67 may be articulated in directions other than the four indicated by the UP, DOWN, LEFT and RIGHT arrows, for example, by proximally translating more than one of the cables 1190, 1192, 1194, 1196. Also, the degree of proximal translation of any given cable 1190, 1192, 1194, 1196 may affect the degree of articulation toward the cable, with more proximal translation corresponding to more severe bending at the articulation joint 1186.

[0223] FIG. 68 illustrates one embodiment of a surgical instrument 1200 for use with a robotic surgical system, such as the system 500, comprising a translatable end effector 1202. The instrument may comprise an instrument mounting portion 1204 comprising a housing 1001.

A shaft 1003 may extend from the instrument mounting portion 1204. The instrument mounting portion 1204 is shown coupled to a robotic arm 1214 comprising a trocar 1216. The trocar 1216 is illustrated deployed within a patient 1218. The shaft 1003 and end effector 1202 extend through the trocar 1216 to access tissue of the patient 1218.

[0224] The instrument 1200 illustrated in FIG. 68 may be an ultrasonic instrument. For example, the end effector 1202 may comprise an ultrasonic blade 1220 and optional clamp arm 1222, for example, in the manner described herein above. The ultrasonic blade 1220 may be coupled to a waveguide 1212 that may extend proximally to be acoustically coupled to an ultrasonic transducer 1208. In one embodiment, the transducer 1208, waveguide 1212, shaft 1003 and end effector 1202 are coupled to one another and are translatable relative to the instrument mounting portion 1204 along the direction of a longitudinal axis. For example, a proximal shaft portion 1211 may comprise an exterior rack gear 1210. The rack gear 1210 may be coupled to a gear 1206. The gear 1206 may be coupled to a rotatable body 612 of the instrument mounting portion 1204 to rotate the gear. When the gear 1206 rotates, it may interface with the rack gear 1210 to alternately translate the shaft 1003, transducer 1208, end effector 1202 and waveguide 1212 distally and proximally, for example, as indicated by arrow 1224.

[0225] FIG. 69A illustrates one embodiment of an articulatable shaft portion 1230 that may be used in conjunction with a surgical instrument. The shaft portion 1230 comprises a proximal tube 1232, a distal tube 1234 and a flexible portion 1233. FIG. 69B illustrates an additional view of one embodiment of the flexible articulation joint section 1233 of the shaft portion 1230. An end effector 1236 may be coupled to a distal portion of the distal tube 1234. The end effector 1236 may be any suitable type of ultrasonic, electrosurgical or combined end effector, as described herein. In various embodiments, wires, waveguides, actuation members such as axially movable member 378, *etc.* may pass to the end effector 1236 within the tubes 1232, 1234 and flexible portion 1233.

[0226] Articulation cables 1254 and 1256 may extend through the proximal tube 1232, distal tube 1234 and articulation portion 1233. The cables 1254, 1256 may be made of any suitable material and, in some embodiments, may comprise braided steel or other metal. The proximal tube 1232 may define first and second channels 1238, 1240 for receiving the articulation cables 1254, 1256. The articulation portion 1233 may define corresponding channels

1242, 1242. Likewise the distal tube 1234 may define corresponding channels 1246, 1248. The articulation cables 1254, 1256 may extend through the respective channels. For example, cable 1254 may extend through channels 1238, 1242 and 1246. Cable 1256 may extend through channels 1240, 1244 and 1248. In various embodiments, cables 1254, 1256 may be coupled to the distal tube 1234 and/or end effector 1236 in any suitable manner. For example, the cables 1254, 1256 may be welded to the distal tube 1234 and/or end effector 1236. Also, in some embodiments, channels 1246, 1248 extend completely through the distal tube 1234 such that cables 1254, 1256 extend beyond the distal tube 1234. The cables 1254, 1256 may terminate with crimp balls 1250, 1252 or other features having a diameter larger than the diameter of the channels 1246, 1248.

[0227] The components of the shaft portion 1230 may be constructed in any suitable manner. In some embodiments, the components of the shaft portion 1230 may be formed from rolled flat stock with the respective channels comprising coil pipes or other tubes welded to the flat stock. For example, FIG. 70 illustrates one embodiment of a piece of flat stock 1260 with a pair of coil pipes 1262, 1264 welded thereto. The flat stock 1260 may be any suitable flexible material that can ultimately be used to construct the proximal tube 1232 or distal tube 1234 of the shaft portion 1230. For example, the flat stock 1260 may be made of steel. The coil pipes 1262, 1262 may be welded to the flat stock, as shown. In various embodiments, any suitable tubular structure may be used in place of coil pipes. FIG. 71 illustrates one embodiment of the flat stock 1260 rolled into a tube shape. A seam 1266 may be fastened using any suitable method including, for example a weld. The rolled stock 1260, as illustrated in FIG. 71, may form all or a part of the proximal tube 1232, the distal tube 1234 and/or the flexible articulation portion 1233 of FIG. 69A.

[0228] Referring now to FIG. 69B, the flexible articulation section 1233 may also be constructed in any suitable manner. For example, the flexible articulation section 1233 may be constructed from an elastomeric material, such as rubber, allowing it to flex as described. Also, in some embodiments, the flexible articulation section 1233 may be made from a metal formed into an accordion-like shape, as illustrated in FIG. 69B, so as to allow flexibility.

[0229] Referring again to FIG. 69A, articulation of the end effector 1236 and distal tube 1234 may be brought about by differential translation of the articulation cables 1254, 1256. For example, proximal translation of the cable 1254 may cause articulation at the flexible

articulation portion 1233, pulling the end effector 1236 and distal tube 1234 proximally toward the cable 1254. Similarly, proximal translation of the cable 1256 may cause articulation at the flexible articulation portion 1233, pulling the end effector 1236 and distal tube 1234 proximally toward the cable 1256. In some embodiments, when one of the cables 1254, 1256 is pulled proximally, the other cable may be extended distally. The presence of the channels 1238, 1240, 1242, 1244, 1246, 1248 may, in some embodiments, prevent the cables 1254, 1256 from binding as the cables are pushed distally.

[0230] The cables 1254, 1256 may be differentially translated in any suitable manner. For example, FIG. 72 illustrates one embodiment of an instrument mounting portion 1266 that may be utilized to effect differential translation of the cables 1254, 1256. Cables 1256, 1254 may be routed by pulleys 1270, 1272 to a spool 1268 mounting on a rotatable body 612 of the instrument mounting portion 1266. In some embodiments, cables 1254, 1256 may be ends of a common cable wound around the spool 1268. Rotation of the spool 1268 may alternately cause distal and proximal translation of the cables 1254, 1256. Differential translation of the cables 1254, 1256 may also be effected, for example, as described above with respect to FIGS. 25-46B. In some embodiments, the shaft portion 1230 may be utilized in conjunction with a hand held or manual instrument. In such embodiments, a spool, such as spool 1268 may be actuated by a lever, such as the lever 1152 shown in FIGS. 60-61.

[0231] FIG. 73 illustrates one embodiment of an instrument mounting portion 1270 comprising a battery assembly 1272 for powering the at least one energy element (*e.g.*, ultrasonic and/or electrosurgical). In the configuration shown in FIG. 73, the instrument mounting portion 1270 is coupled to an ultrasonic transducer 1274 for use with an ultrasonic blade (not shown). Some robotic surgical systems provide instrument mounting portions, such as 1270 with limited power (*e.g.*, 12 volts). Often the power provided is not sufficient to power energy elements such as ultrasonic transducers/blades, electrosurgical elements, *etc.*, that may be utilized with instrument end effectors to treat tissues. Accordingly, instrument mounting portions for instruments utilizing energy elements often require exterior power sources, such as exterior cables. The instrument mounting portion 1270 comprises the battery assembly 1272 for powering at least one energy element. The battery assembly 1272 may comprise any suitable type of battery cell or cells including, for example, a lithium-ion cell.

[0232] In some embodiments, the battery assembly 1272 may be charged utilizing an inductive coil 1276. The inductive coil 1276 is shown wrapped around the transducer 1274 but may be placed in any suitable location. The coil 1276 may be coupled to the battery assembly by leads 1273, 1275. A second inductive coil 1278 is displayed installed on the transducer 1274 next to the first coil 1276. The second coil 1276 may be electrically coupled to a power source, such as a wall outlet, and may provide a power signal for inductively charging the battery assembly 1272 via the first coil 1276. In some embodiments, the power source may be located within the robotic surgical system such as, for example, in an arm of the robot. Also, in some embodiments, the power source within the robot may be electrically connected to charge the battery when the robotic surgical system is not in use and connected to charge the battery when the robotic surgical system is in use.

[0233] FIG. 74 illustrates one embodiment of the instrument mounting portion 1270 further comprising a generator circuit 1271. The generator circuit 1271 may operate in a manner similar to that described above with respect to generators 20, 320 to drive an energy element, for example, with power from the battery assembly 1272. For example, when an ultrasonic instrument 522 is utilized, the generator circuit 1271 may provide an ultrasonic drive signal in a manner similar to that described above with respect to generator 20. Also, for example, when an RF instrument 523 or ultrasonic instrument 522 capable of providing a therapeutic or non-therapeutic RF signal is used, the generator circuit 1271 may provide an RF drive signal, for example, as described herein above with respect to the module 23 of generator 20 and/or the generator 320. In some embodiments, the generator circuit 1271 may be configured in a manner similar to that of the control circuit 440 described herein above with respect to FIGS. 18B-18C. In some embodiments, the generator circuit 1271 and/or battery assembly 1272 may comprise a sensor for sensing a charge of the battery assembly 1272. The sensor may be any suitable type of sensor. In some embodiments, the sensor comprises a resistor configured such that a voltage drop across the resistor indicates a voltage provided by the battery assembly 1272. The sensor may be in communication with a communications bus (not shown) of the robotic surgical system 500 such that a state of the battery assembly 1272 may be derived by the robotic surgical system and displayed to the clinician (*e.g.*, via display 521).

[0234] FIG. 75 illustrates one embodiment of an instrument mounting portion 1280 with a cord-based generator circuit 1284. The cord 1282 may be electrically coupled to the

instrument mounting portion 1280, for example, to provide suitable power to power an energy element for treating tissue. The generator circuit 1284 may operate in a manner similar to that of the generator circuit 1271 described herein above. Instead of being within the instrument mounting portion 1280, however, the generator circuit 1284 may be positioned in series with the cord 1282.

[0235] FIG. 76 illustrates one embodiment of an instrument mounting portion 1286 comprising a removable battery assembly 1290. The battery assembly 1290 may power one or more energy elements positioned at an end effector 1288. The battery assembly 1290 may comprise any suitable battery cell or cells, for example, as described above with respect to the battery assembly 1272. The assembly 1290 may be received within an exterior socket 1292 in the housing 1001 of the instrument mounting portion 1286. When the battery assembly 1290 requires re-charging, it may be removed from the exterior socket 1292 and charged. In some embodiments, the battery assembly 1290 and/or the housing 1001 may further comprise a generator circuit, such as the generator circuit 1271.

[0236] FIG. 77 illustrates one embodiment of a surgical system 1294 with a wireless foot pedal 1296 for actuating an energy element. The system 1294 may also comprise an instrument mounting portion 1293 coupled to a shaft comprising an end effector 1295. The end effector 1295 may comprise at least one energy element for treating tissue. The foot pedal 1296 may be coupled to a transmitter 1298. The transmitter 1298 may be external to the pedal 1296 as shown, or may be embodied as a circuit and/or antenna within the foot pedal 1296 itself. When the pedal 1296 is actuated (*e.g.*, by clinician's foot 1291) the transmitter 1298 may emit a signal that may be received by a receiver 1297 positioned in or in communication with the instrument mounting portion 1293 or other component of the robotic surgical system (*e.g.*, 500). Upon receipt of the signal, the instrument mounting portion 1293 or other component of the robotic surgical system may energize an energy element of the end effector 1295.

[0237] FIGS. 78-83 illustrate one embodiment of a passive articulation mechanism for use with a robotic surgical system and/or manual surgical instrument. FIG. 78 illustrates one embodiment of a shaft portion 1300. The shaft portion 1300 comprises a distal end 1301 that may be directly or indirectly coupled to an end effector for treating tissue (not shown) such as one of the end effectors described herein. A proximal shaft portion 1314 may extend proximally and may be coupled to an instrument mounting portion or handle (not shown). Member 1310

represents various connections that may be made between the end effector and handle or instrument mounting portion. Such connections may include, for example, a waveguide for acoustically coupling a transducer and an ultrasonic blade, wires for providing drive signals to one or more electrosurgical electrodes, *etc.*

[0238] An articulation joint 1302 may comprise a plurality of interfacing joint members 1304. The joint members 1304 may be configured to slide over one another to change the orientation of the articulation joint 1302. FIG. 79 shows an example of a flexible boot 1305 that may be positioned over the articulation joint 1302. The boot 1305 may flex with the articulation joint 1302. In various embodiments, the boot 1305 may prevent individual joint members 1304 from sliding too far relative to one another. Also, in some embodiments, the boot 1305 may contain oil or another lubricant for allowing the joint members 1304 to slide relative to one another.

[0239] In some embodiments, as shown in FIG. 80, some or all of the joint members 1304 define distally-facing concave faces and proximally-facing convex faces. Accordingly, adjacent joint members may slide over one another to articulate the joint 1302, as shown in FIG. 80. Articulation cables 1306, 1308 may extend through the proximal shaft portion 1314 and joint members 1302. For example, each joint member may define channels 1312 for receiving the cables 1306, 1308. In various embodiments, the articulation joint 1302 is a passive articulation joint. For example, when the cables 1306, 1308 are loosened or have slack, the clinician may articulate the joint 1302, either with his or her hand or by pushing the end effector (not shown) or distal shaft portion 1307 against tissue at a surgical site. This may cause the joint members 1304 to slide over one another as shown in FIG. 80. When the cables 1306, 1308 are tightened, the joint members 1304 may not be free to slide over one another, thus locking the joint 1302 in place. For example, the joint 1302 may be locked in an articulated position, as shown in FIG. 78, or in a straight position, as shown in FIG. 80.

[0240] FIGS. 81-82 illustrate one embodiment of a mechanism 1329 for alternately loosening and tightening the cables 1306, 1308 so as to alternately allow and prevent articulation at the joint 1302. The mechanism 1329 may be positioned, for example, at a handle and/or instrument mounting portion. For example, the cables 1306, 1308 may extend proximally through the proximal shaft portion 1314 and between a rotor 1320 and a pair of posts 1322, 1324. The rotor 1320 may comprise convex faces 1330 and concave faces 1332. When the rotor

1320 is rotated such that its concave faces 1332 face the posts 1322, 1324, the cables 1306, 1308 may be free to slide freely between the rotor 1320 and the respective posts 1322, 1324. The rotor 1320 may also be rotated to the position shown in FIG. 82, however, where a portion of the rotor 1320 (*e.g.*, the convex portion 1330 and/or an edge of the concave portion 1332) pinches the respective cables 1306, 1308 between the rotor 1320 and respective posts 1322, 1322. In this position, no slack in the cables 1306, 1308 may be available, thus locking the position of the articulation joint 1302.

[0241] FIG. 83 illustrates one embodiment of an instrument mounting portion 1340 that may contain the mechanism 1329. For example, the rotor 1320 may be mounted on a rotatable body 612 to be controlled by the robotic surgical system, as described herein. Cables 1306, 1308 may terminate, for example, against the housing 1001 at termination points 1342, 1344 as shown. The termination points 1342, 1344 may be positioned at any suitable location. For example, the termination points 1342, 1344 may be positioned against the housing 1001, as shown, or against any other mechanism or component of the instrument mounting portion 1340. In some embodiments, the cables 1306, 1308 and/or distal portions thereof may comprise respective springs or elastic portions 1346, 1348. The elastic portions 1346, 1348 may allow the cables 1306, 1308 to extend distally, for example, when the articulation joint 1302 is in an articulated position.

[0242] *Non-Limiting Embodiments*

[0243] Various embodiments are directed to surgical instruments for use in handheld applications or with robotic surgical systems. The surgical instruments may comprise an end effector to treat tissue and a shaft extending proximally from the end effector along a longitudinal axis. In various embodiments, a surgical instrument may further comprise a waveguide extending proximally from an ultrasonic blade through the shaft. The waveguide may define a bendable portion at about the flexible articulation joint. A first plate may be positioned distally from the flexible articulation joint at a node of at least one of the waveguide and the ultrasonic blade. First and second helical cables may be coupled to the first plate at points offset from the longitudinal axis and may extend proximally. A gear may be positioned proximally from the flexible articulation joint and may have a first side that interlocks with the first helical cable and a second side that interlocks with a second helical cable such that rotation of the gear causes differential translation of the first and second helical cables.

[0244] In other embodiments, the shaft of the surgical instrument comprises a proximal tube and a distal tube. An end effector may be coupled to a distal portion of the distal tube and a flexible articulation portion may be positioned between the proximal tube and the distal tube. In various embodiments, the proximal tube defines a first channel positioned near an interior wall of the proximal tube. The surgical instrument may also comprise a first articulation cable coupled to at least one of the end effector and the distal tube and extending proximally through the first channel of the proximal tube such that proximal translation of the first articulation cable pulls the distal tube and the end effector away from the longitudinal axis towards the first articulation cable.

[0245] In another embodiment, the flexible articulation portion comprises a plurality of interfacing joint members. Each of the joint members may define first and second channels. A first articulation cable may be coupled to at least one of the end effector and the distal tube and may extend through the first channels of the plurality of joint members. A second articulation cable may be coupled to at least one of the end effector and the distal tube and may extend through the second channels of the plurality of joint members. The first and second articulation cables may be transitionable between an unlocked position where the first and second cables are free to translate distally and proximally and the plurality of joint members are slidable relative to one another to pivot the distal tube and end effector away from the longitudinal axis, and a locked position where translation of the first and second cables is locked, causing the position of the end effector and distal tube relative to the longitudinal axis to also be locked.

[0246] Various embodiments are directed to surgical instruments for use with robotic surgical systems. The surgical instruments may comprise an end effector to treat tissue, a shaft extending proximally from the end effector along a longitudinal axis and a housing. The shaft may be coupled to a distal end of the housing. In various embodiments, a surgical instrument comprises a first magnetic element positioned within the housing. A first cable may be coupled to the first magnetic element and may extend distally from the first magnetic element and distally through the shaft such that actuation of the magnetic element causes the first cable to translate along the longitudinal axis. The first magnetic element may be actuated by a rotatable body positioned within the housing. An actuation member may extend from the rotatable body to a switch of the first magnetic element such that rotation of the rotatable body alternately transitions

the switch from a first position where the first magnetic element is actuated to a second position where the first magnetic element is not actuated.

[0247] In various embodiments, a surgical instrument comprises a first rotatable body positioned within the housing and comprising a first peg offset from a center of rotation of the first rotatable body. A second rotatable body may also be positioned within the housing and may comprise a second peg offset from a center of rotation of the second rotatable body. An elastic band may be coupled to the first peg and the second peg. Further, a cable may be coupled to the elastic band and extend distally through the shaft. Rotation of the first and second rotatable bodies that moves the first and second pegs proximally also pulls the elastic band and cable proximally.

[0248] In various embodiments, a surgical instrument comprises a first rotatable body positioned within the housing and comprising a first peg offset from a center of rotation of the first rotatable body. A second rotatable body may also be positioned within the housing and may comprise a second peg offset from a center of rotation of the second rotatable body. A rotational axis of the first rotatable body may be positioned distally from a rotational axis of the second rotatable body. A cable may be fixedly secured to an interior portion of the housing, routed by the first and second pegs, and extend distally through the shaft such that rotation of the first and second rotatable bodies causes the cable to translate along the longitudinal axis.

[0249] In various embodiments, the end effector comprises an ultrasonic blade. The instrument may further comprise an ultrasonic transducer coupled to a proximal end of the shaft, a waveguide acoustically coupled to the ultrasonic transducer and the ultrasonic blade and extending through the shaft. The shaft may extend through the housing. The shaft, ultrasonic transducer, waveguide, and end effector may be translatable distally and proximally along the longitudinal axis.

[0250] In various embodiments, the end effector comprises at least one energy element for providing energy to tissue. The instrument may further comprise a battery assembly for powering the at least one energy element. The battery assembly may comprise a rechargeable battery positioned within the housing. The rechargeable battery may be electrically coupled to the at least one energy element. The battery assembly may also comprise an inductive coil coupled to the rechargeable battery. The inductive coil may be positioned to be placed in proximity with a second inductive coil providing electrical energy for recharging the battery.

[0251] In various embodiments where the end effector comprises at least one energy element, the instrument further comprises a power cord electrically coupled to the at least one energy element and extending from the housing. The power cord may comprise therein a generator for providing a drive signal to the at least one energy element. Also, in various embodiments where the end effector comprises at least one energy element, the instrument further comprises a removable battery assembly for powering the at least one energy element. The removable battery assembly may be receivable into the exterior socket of the housing to be in electrical communication with the at least one energy element.

[0252] Applicant also owns the following patent applications that are each incorporated by reference in their respective entireties:

[0253] U.S. Patent Application Serial No. 13/536,271, filed on June 28, 2012 and entitled "Flexible Drive Member," (Attorney Docket No. END7131USNP/120135);

[0254] U.S. Patent Application Serial No. 13/536,288, filed on June 28, 2012 and entitled "Multi-Functional Powered Surgical Device with External Dissection Features," (Attorney Docket No. END7132USNP/120136);

[0255] U.S. Patent Application Serial No. 13/536,295, filed on June 28, 2012 and entitled "Rotary Actuatable Closure Arrangement for Surgical End Effector," (Attorney Docket No. END7134USNP/120138);

[0256] U.S. Patent Application Serial No. 13/536,326, filed on June 28, 2012 and entitled "Surgical End Effectors Having Angled Tissue-Contacting Surfaces," (Attorney Docket No. END7135USNP/120139);

[0257] U.S. Patent Application Serial No. 13/536,303, filed on June 28, 2012 and entitled "Interchangeable End Effector Coupling Arrangement," (Attorney Docket No. END7136USNP/120140);

[0258] U.S. Patent Application Serial No. 13/536,393, filed on June 28, 2012 and entitled "Surgical End Effector Jaw and Electrode Configurations," (Attorney Docket No. END7137USNP/120141);

[0259] U.S. Patent Application Serial No. 13/536,362, filed on June 28, 2012 and entitled "Multi-Axis Articulating and Rotating Surgical Tools," (Attorney Docket No. END7138USNP/120142); and

[0260] U.S. Patent Application Serial No. 13/536,417, filed on June 28, 2012 and entitled “Electrode Connections for Rotary Driven Surgical Tools,” (Attorney Docket No. END7149USNP/120153).

[0261] It will be appreciated that the terms “proximal” and “distal” are used throughout the specification with reference to a clinician manipulating one end of an instrument used to treat a patient. The term “proximal” refers to the portion of the instrument closest to the clinician and the term “distal” refers to the portion located furthest from the clinician. It will further be appreciated that for conciseness and clarity, spatial terms such as “vertical,” “horizontal,” “up,” or “down” may be used herein with respect to the illustrated embodiments. However, surgical instruments may be used in many orientations and positions, and these terms are not intended to be limiting or absolute.

[0262] Various embodiments of surgical instruments and robotic surgical systems are described herein. It will be understood by those skilled in the art that the various embodiments described herein may be used with the described surgical instruments and robotic surgical systems. The descriptions are provided for example only, and those skilled in the art will understand that the disclosed embodiments are not limited to only the devices disclosed herein, but may be used with any compatible surgical instrument or robotic surgical system.

[0263] Reference throughout the specification to “various embodiments,” “some embodiments,” “one example embodiment,” or “an embodiment” means that a particular feature, structure, or characteristic described in connection with the embodiment is included in at least one example embodiment. Thus, appearances of the phrases “in various embodiments,” “in some embodiments,” “in one example embodiment,” or “in an embodiment” in places throughout the specification are not necessarily all referring to the same embodiment. Furthermore, the particular features, structures, or characteristics illustrated or described in connection with one example embodiment may be combined, in whole or in part, with features, structures, or characteristics of one or more other embodiments without limitation.

[0264] While various embodiments herein have been illustrated by description of several embodiments and while the illustrative embodiments have been described in considerable detail, it is not the intention of the applicant to restrict or in any way limit the scope of the appended claims to such detail. Additional advantages and modifications may readily appear to those skilled in the art. For example, each of the disclosed embodiments may be employed in

endoscopic procedures, laparoscopic procedures, as well as open procedures, without limitations to its intended use.

[0265] It is to be understood that at least some of the figures and descriptions herein have been simplified to illustrate elements that are relevant for a clear understanding of the disclosure, while eliminating, for purposes of clarity, other elements. Those of ordinary skill in the art will recognize, however, that these and other elements may be desirable. However, because such elements are well known in the art, and because they do not facilitate a better understanding of the disclosure, a discussion of such elements is not provided herein.

[0266] While several embodiments have been described, it should be apparent, however, that various modifications, alterations and adaptations to those embodiments may occur to persons skilled in the art with the attainment of some or all of the advantages of the disclosure. For example, according to various embodiments, a single component may be replaced by multiple components, and multiple components may be replaced by a single component, to perform a given function or functions. This application is therefore intended to cover all such modifications, alterations and adaptations without departing from the scope and spirit of the disclosure as defined by the appended claims.

[0267] Any patent, publication, or other disclosure material, in whole or in part, that is said to be incorporated by reference herein is incorporated herein only to the extent that the incorporated materials does not conflict with existing definitions, statements, or other disclosure material set forth in this disclosure. As such, and to the extent necessary, the disclosure as explicitly set forth herein supersedes any conflicting material incorporated herein by reference. Any material, or portion thereof, that is said to be incorporated by reference herein, but which conflicts with existing definitions, statements, or other disclosure material set forth herein will only be incorporated to the extent that no conflict arises between that incorporated material and the existing disclosure material.

CLAIMS

What is claimed is:

1. A surgical instrument for use with a robotic surgical system, the surgical instrument comprising:
 - an end effector to treat tissue;
 - a shaft extending proximally from the end effector along a longitudinal axis;
 - a housing, wherein the shaft is coupled to a distal end of the housing;
 - a first magnetic element positioned within the housing;
 - a first cable coupled to the first magnetic element and extending distally from the first magnetic element and distally through the shaft such that actuation of the magnetic element causes the first cable to translate along the longitudinal axis;
 - a rotatable body positioned within the housing; and
 - an actuation member extending from the rotatable body to a switch of the first magnetic element such that rotation of the rotatable body alternately transitions the switch from a first position where the first magnetic element is actuated to a second position where the first magnetic element is not actuated.

2. The surgical instrument of claim 1, further comprising:
 - a second magnetic element positioned within the housing; and
 - a second cable coupled to the second magnetic element and extending distally from the second magnetic element and distally through the shaft such that actuation of the second magnetic element causes the second cable to translate along the longitudinal axis; and
 - a second actuation member extending from the rotatable body to a switch of the second magnetic element such that rotation of the rotatable body alternately transitions the switch of the second magnetic element from a first position where the second magnetic element is actuated to a second position where the second magnetic element is not actuated.

3. The surgical instrument of claim 2, wherein the rotatable body is rotatable to a first position where both the first and second magnetic elements are not actuated; to a second position where the first magnetic element is actuated and the second magnetic element is not actuated; and to a third position where the first and second magnetic elements are not actuated.

4. The surgical instrument of claim 2, further comprising:
a third magnetic element positioned within the housing; and
a third cable coupled to the third magnetic element and extending distally from the third magnetic element and distally through the shaft such that actuation of the second magnetic element causes the second cable to translate along the longitudinal axis; and
a third actuation member extending from the rotatable body to a switch of the third magnetic element such that rotation of the rotatable body alternately transitions the switch of the third magnetic element from a first position where the third magnetic element is actuated to a second position where the third magnetic element is not actuated.

5. The surgical instrument of claim 4, wherein the rotatable body is rotatable:
to a first position where the first, second and third magnetic elements are actuated;
to a second position where the first and second magnetic elements are actuated and the third magnetic element is not actuated;
to a third position wherein the first magnetic element is actuated and the second and third magnetic elements are not actuated; and
to a fourth position where the first, second and third magnetic elements are not actuated.

6. The surgical instrument of claim 5 wherein the rotatable body is rotatable:
to a fifth position where the first and second magnetic elements are not actuated and the third magnetic element is actuated;
to a sixth position where the first magnetic element is not actuated and the second and third magnetic elements are actuated.

7. The surgical instrument of claim 1, further comprising:
a second magnetic element positioned within the housing;
a second cable coupled to the second magnetic element and extending distally from the second magnetic element and distally through the shaft such that actuation of the second magnetic element causes the second cable to translate along the longitudinal axis;
a second rotatable body positioned within the housing; and

a second actuation member extending from the second rotatable body to a switch of the second magnetic element such that rotation of the rotatable body alternately transitions the switch of the second magnetic element from a first position where the second magnetic element is actuated to a second position where the second magnetic element is not actuated.

8. The surgical instrument of claim 1, wherein the shaft comprises a flexible articulation joint, and wherein the first cable is coupled to the shaft distally from the flexible articulation joint and offset from the longitudinal axis such that proximal translation of the first cable causes pivoting of the end effector away from the longitudinal axis towards the first cable.

9. The surgical instrument of claim 8, wherein the end effector comprises an ultrasonic blade, further comprising a transducer assembly positioned distally from the flexible articulation joint and acoustically coupled to the ultrasonic blade.

10. The surgical instrument of claim 1, wherein a proximal portion of the shaft extends proximally along the longitudinal axis within the housing, and further comprising:
a second magnetic element positioned within the housing;
a second cable having a proximal end coupled to the second magnetic housing and a distal end positioned around the proximal portion of the shaft, wherein actuation of the second magnetic element unwraps the second cable from the proximal portion of the shaft, causing rotation of the shaft.

11. The surgical instrument of claim 1, further comprising:
a second rotatable body; and
a second cable coupled to the second rotatable body and extending distally from the first rotatable body through the shaft such that rotation of the second rotatable body causes the second cable to translate along the longitudinal axis.

12. A surgical instrument for use with a robotic surgical system, the surgical instrument comprising:
an end effector to treat tissue;

a shaft extending proximally from the end effector along a longitudinal axis;
a housing, wherein the shaft is coupled to a distal end of the housing;
a first rotatable body positioned within the housing, wherein the first rotatable body comprises a first peg offset from a center of rotation of the first rotatable body;
a second rotatable body positioned within the housing, wherein the second rotatable body comprises a second peg offset from a center of rotation of the second rotatable body;
an elastic band coupled to the first peg and the second peg; and
a cable coupled to the elastic band and extending distally through the shaft, wherein rotation of the first and second rotatable bodies that moves the first and second pegs proximally also pulls the elastic band and cable proximally.

13. The surgical instrument of claim 12, wherein rotation of the first and second rotatable bodies that moves the first and second pegs distally also pushes the elastic band and cable proximally.

14. A surgical instrument for use with a robotic surgical system, the surgical instrument comprising:
an end effector to treat tissue;
a shaft extending proximally from the end effector along a longitudinal axis;
a housing, wherein the shaft is coupled to a distal end of the housing;
a first rotatable body positioned within the housing, wherein the first rotatable body comprises a first peg offset from a center of rotation of the first rotatable body;
a second rotatable body positioned within the housing, wherein the second rotatable body comprises a second peg offset from a center of rotation of the second rotatable body, and where a rotational axis of the first rotatable body is positioned distally from a rotational axis of the second rotatable body; and
a cable fixedly secured to an interior portion of the housing, routed by the first and second pegs, and extending distally through the shaft such that rotation of the first and second rotatable bodies causes the cable to translate along the longitudinal axis.

15. A surgical instrument comprising:

an end effector comprising an ultrasonic blade;

a shaft extending proximally from the end effector along a longitudinal axis, the shaft defining a flexible articulation joint;

a waveguide extending proximally from the ultrasonic blade through the shaft, wherein the waveguide defines a bendable portion at about the flexible articulation joint;

a first plate positioned distally from the flexible articulation joint at a node of at least one of the waveguide and the ultrasonic blade;

a first helical cable coupled to the first plate at a first point offset from the longitudinal axis and extending proximally;

a second helical cable coupled to the first plate at a second point offset from the longitudinal axis and extending proximally;

a gear, positioned proximally from the flexible articulation joint, wherein a first side of the gear interlocks with the first helical cable and a second side of the gear interlocks with the second helical cable such that rotation of the gear causes differential translation of the first and second helical cables.

16. The surgical instrument of claim 15, wherein rotation of the gear in a first direction causes proximal translation of the first cable, pivoting the first plate and end effector away from the longitudinal axis towards the first cable.

17. The surgical instrument of claim 16, wherein rotation of the gear in a second direction causes proximal translation of the second cable, pivoting the first plate and end effector away from the longitudinal axis towards the second cable.

18. The surgical instrument of claim 15, further comprising a housing for interfacing with a robotic surgical system, wherein the gear is coupled to a rotatable body positioned within the housing.

19. The surgical instrument of claim 15, further comprising a handle comprising an articulation lever coupled to the gear.

20. A surgical instrument for use with a robotic surgical system, the surgical instrument comprising:

an end effector to treat tissue, the end effector comprising an ultrasonic blade;

a shaft extending proximally from the end effector along a longitudinal axis;

an ultrasonic transducer coupled to a proximal end of the shaft;

a waveguide acoustically coupled to the ultrasonic transducer and the ultrasonic blade and extending through the shaft; and

a housing, wherein the shaft extends through the housing, and wherein the shaft, ultrasonic transducer, waveguide, and end effector are translatable distally and proximally along the longitudinal axis.

21. The surgical instrument of claim 20, further comprising:

a rack gear coupled to the shaft at a portion of the shaft within the housing; and

a rotatable body positioned within the housing; and

a gear coupled to the rotatable body and interfaced with the rack gear such that rotation of the gear translates the shaft ultrasonic transducer, waveguide and end effector distally and proximally along the longitudinal axis.

22. The surgical instrument of claim 20, further comprising a robotic manipulator arm, wherein the housing is coupled to the robotic manipulator arm, and wherein the manipulator arm comprises a trocar mounted distally from the housing, wherein the shaft extends through the trocar.

23. A surgical instrument comprising:

an end effector to treat tissue;

a shaft extending proximally from the end effector along a longitudinal axis, wherein the shaft comprises:

a proximal tube defining a first channel positioned near an interior wall of the proximal tube;

a distal tube, wherein the end effector is coupled to a distal portion of the distal tube; and

a flexible articulation portion positioned between the proximal tube and the distal tube;

a first articulation cable coupled to at least one of the end effector and the distal tube and extending proximally through the first channel of the proximal tube such that proximal translation of the first articulation cable pulls the distal tube and the end effector away from the longitudinal axis towards the first articulation cable.

24. The surgical instrument of claim 23, wherein the proximal tube further defines a second channel positioned near an interior wall of the proximal tube and offset from the first channel about the longitudinal axis, wherein the surgical instrument further comprises:

a second articulation cable coupled to at least one of the end effector and the distal tube and extending proximally through the second channel of the proximal tube such that proximal translation of the second articulation cable pulls the distal tube and the end effector away from the longitudinal axis towards the second articulation cable.

25. The surgical instrument of claim 23, wherein the first articulation cable comprises two cables braided to one another.

26. The surgical instrument of claim 23, wherein the first channel is defined by a coil pipe welded to the interior wall of the proximal tube.

27. The surgical instrument of claim 23, wherein the first channel extends distally beyond the interior wall of the proximal tube.

28. The surgical instrument of claim 23, wherein the flexible articulation portion defines a second channel aligning with the first channel for receiving the first articulation cable.

29. A surgical instrument for use with a robotic surgical system, the surgical instrument comprising:

an end effector to treat tissue, the end effector comprising at least one energy element for providing energy to the tissue;

a shaft extending proximally from the end effector along a longitudinal axis;
a housing, wherein the shaft is coupled to a distal portion of the housing; and
a battery assembly for powering the at least one energy element, wherein the battery assembly comprises:

a rechargeable battery positioned within the housing, wherein the rechargeable battery is electrically coupled to the at least one energy element; and

an inductive coil coupled to the rechargeable battery, wherein the inductive coil is positioned to be placed in proximity with a second inductive coil providing electrical energy for recharging the battery.

30. The surgical instrument of claim 29, wherein the at least one energy element comprises an ultrasonic blade, and wherein the rechargeable battery is electrically coupled to a transducer in ultrasonic communication with the ultrasonic blade.

31. The surgical instrument of claim 29, further comprising a generator circuit positioned within the housing to generate at least one drive signal for the at least one energy element.

32. The surgical instrument of claim 29, further comprising a sensor electrically positioned to sense at least one charge property of the rechargeable battery, wherein the sensor is in electrical communication with a communications bus of the robotic surgical system to provide the at least one charge property of the rechargeable battery to a surgeon display of the robotic surgical instrument.

33. The surgical instrument of claim 29, further comprising:
a foot pedal in electrical communication with a transmitter;
a receiver in electrical communication with the at least one energy element, wherein, upon receipt of a signal from the transmitter indicating that the foot pedal has been actuated, the receiver is to send a signal to actuate the at least one energy element.

34. A surgical instrument for use with a robotic surgical system, the surgical instrument comprising:

an end effector to treat tissue, the end effector comprising at least one energy element for providing energy to the tissue;

a shaft extending proximally from the end effector along a longitudinal axis;

a housing, wherein the shaft is coupled to a distal portion of the housing; and

a power cord electrically coupled to the at least one energy element and extending from the housing, wherein the power cord comprises therein a generator for providing a drive signal to the at least one energy element.

35. The surgical instrument of claim 34, wherein the at least one energy element comprises an ultrasonic blade.

a battery assembly for powering the at least one energy element, wherein the battery assembly comprises:

a rechargeable battery positioned within the housing, wherein the rechargeable battery is electrically coupled to the at least one energy element; and

an inductive coil coupled to the rechargeable battery, wherein the inductive coil is positioned to be placed in proximity with a second inductive coil providing electrical energy for recharging the battery.

36. A surgical instrument for use with a robotic surgical system, the surgical instrument comprising:

an end effector to treat tissue, the end effector comprising at least one energy element for providing energy to the tissue;

a shaft extending proximally from the end effector along a longitudinal axis;

a housing, wherein the shaft is coupled to a distal portion of the housing, and wherein the housing defines an exterior socket; and

a removable battery assembly for powering the at least one energy element, wherein the removable battery assembly is receivable into the exterior socket of the housing to be in electrical communication with the at least one energy element.

37. The surgical instrument of claim 36, further comprising:
a foot pedal in wireless electrical communication with a transmitter;
a receiver in wireless electrical communication with the transmitter and in communication with at least one energy element, wherein, upon receipt of a signal from the transmitter indicating that the foot pedal has been actuated, the receiver is to send a signal to actuate the at least one energy element.

38. The surgical instrument of claim 36, wherein the removable battery assembly further comprises a generator circuit to generate at least one drive signal for the at least one energy element.

39. A surgical instrument comprising:
an end effector to treat tissue;
a shaft extending proximally from the end effector along a longitudinal axis, wherein the shaft comprises:

a proximal tube;

a distal tube, wherein the end effector is coupled to a distal portion of the distal tube; and

a flexible articulation portion positioned between the proximal tube and the distal tube, wherein the flexible articulation portion comprises a plurality of interfacing joint members, and wherein each of the joint members define first and second channels;

a first articulation cable coupled to at least one of the end effector and the distal tube, wherein the first articulation cable extends through the first channels of the plurality of joint members;

a second articulation cable coupled to at least one of the end effector and the distal tube, wherein the second articulation cable extends through the second channels of the plurality of joint members, wherein the first and second articulation cables are transitionable between an unlocked position where the first and second cables are free to translate distally and proximally and the plurality of joint members are slidable relative to one another to pivot the distal tube and end effector away from the longitudinal axis, and a locked position where translation of the first

and second cables is locked, causing the position of the end effector and distal tube relative to the longitudinal axis to also be locked.

40. The surgical instrument of claim 39, further comprising a proximally positioned lock assembly, wherein the lock assembly comprises:

a first post;

a second post;

a rotatable member positioned between the first and second posts, wherein the first articulation cable is routed between the first post and the rotatable member, wherein the second articulation cable is routed between the second post and the rotatable member, wherein the rotatable member comprises a first angular position at which the first articulation cable is passable between the rotatable member and the first post and the second articulation cable is passable between the rotatable member and the second post, and wherein the rotatable member comprises a second angular position at which the first articulation member is locked between the rotatable member and the first post and the second articulation member is locked between the rotatable member and the second articulation member.

41. The surgical instrument of claim 1, wherein the rotatable member defines a convex face, and wherein at the first angular position, the convex face faces the first post.

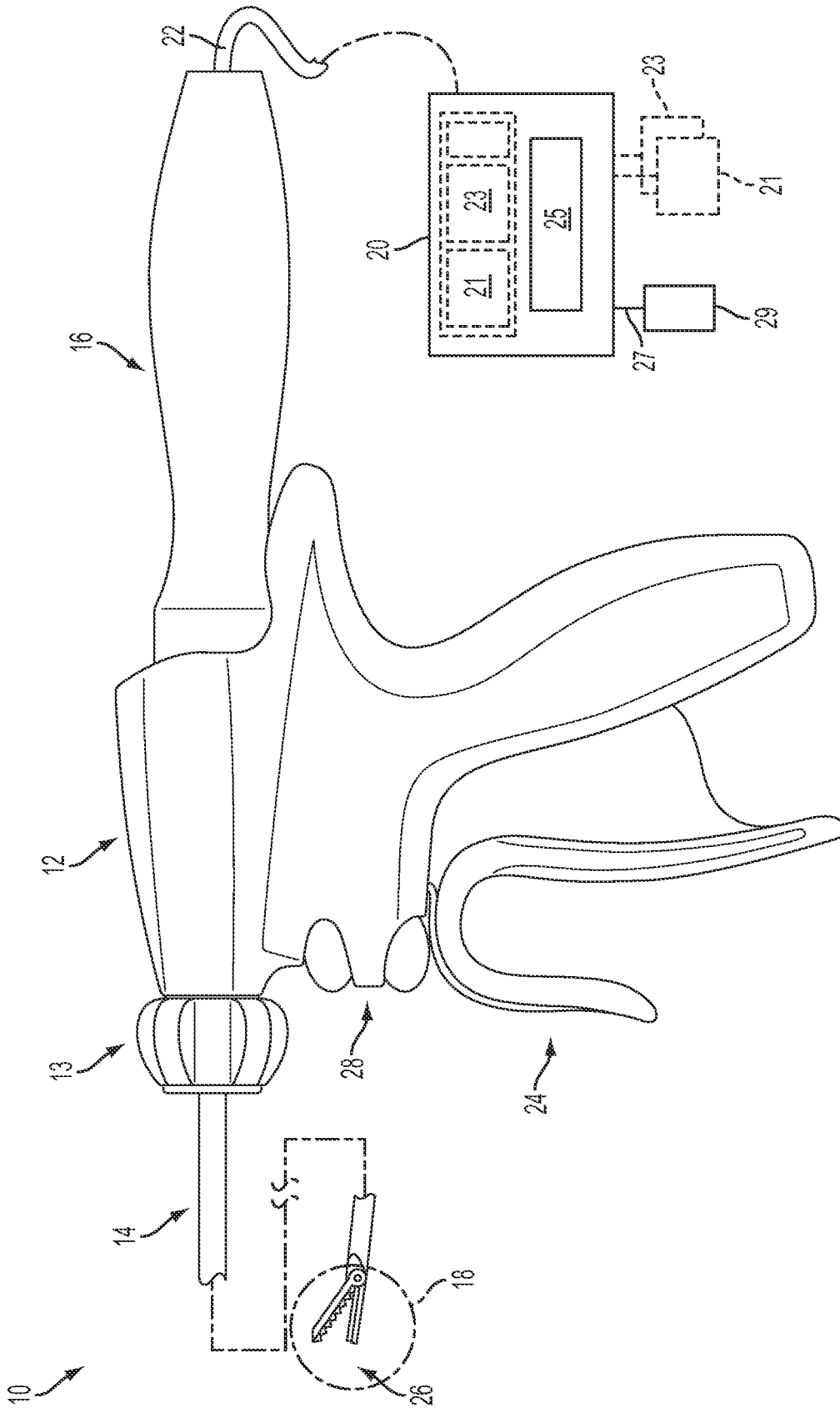

FIG. 1

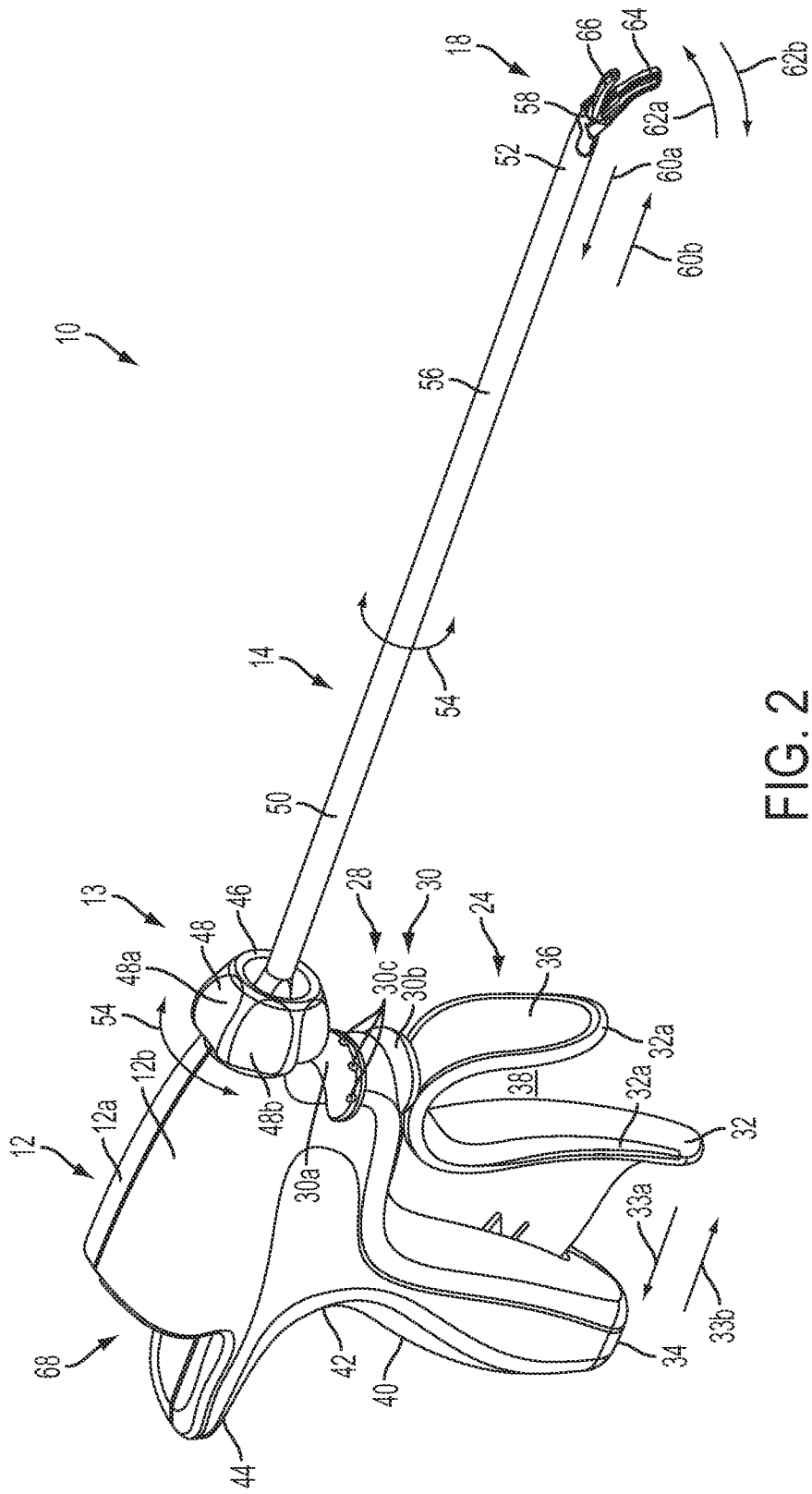

FIG. 2

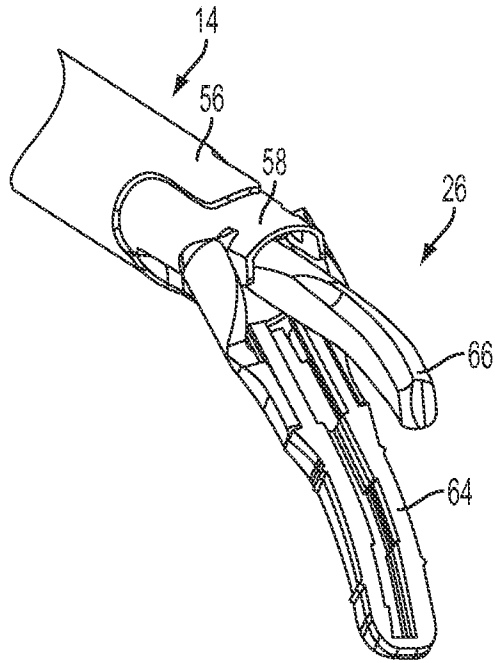

FIG. 3

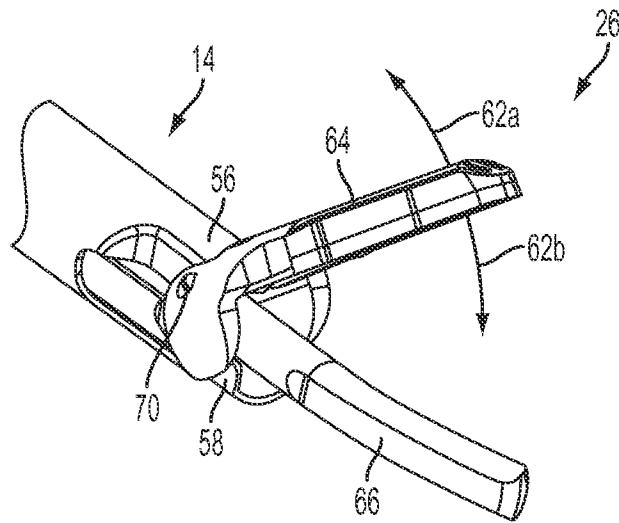

FIG. 4

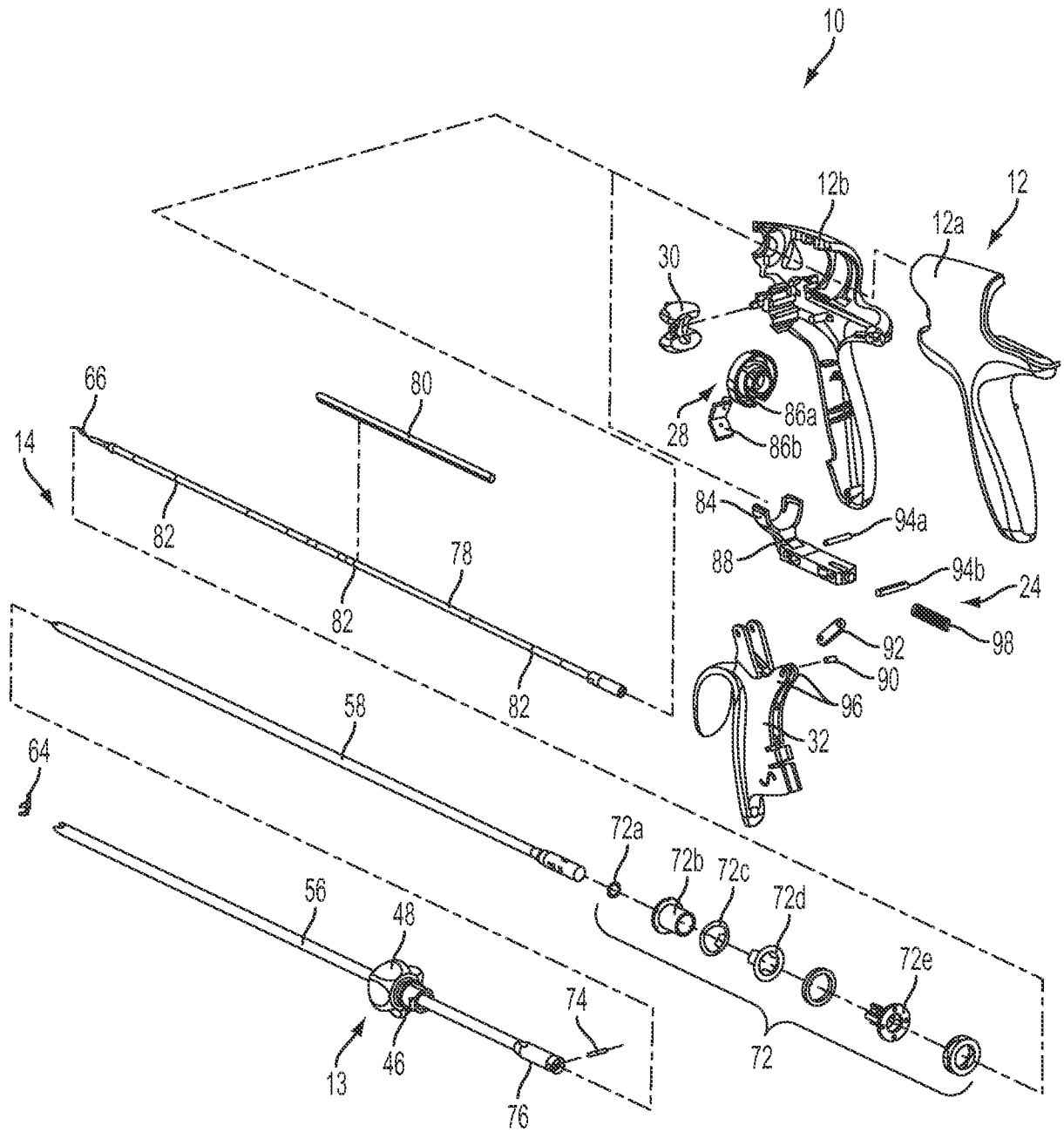

FIG. 5

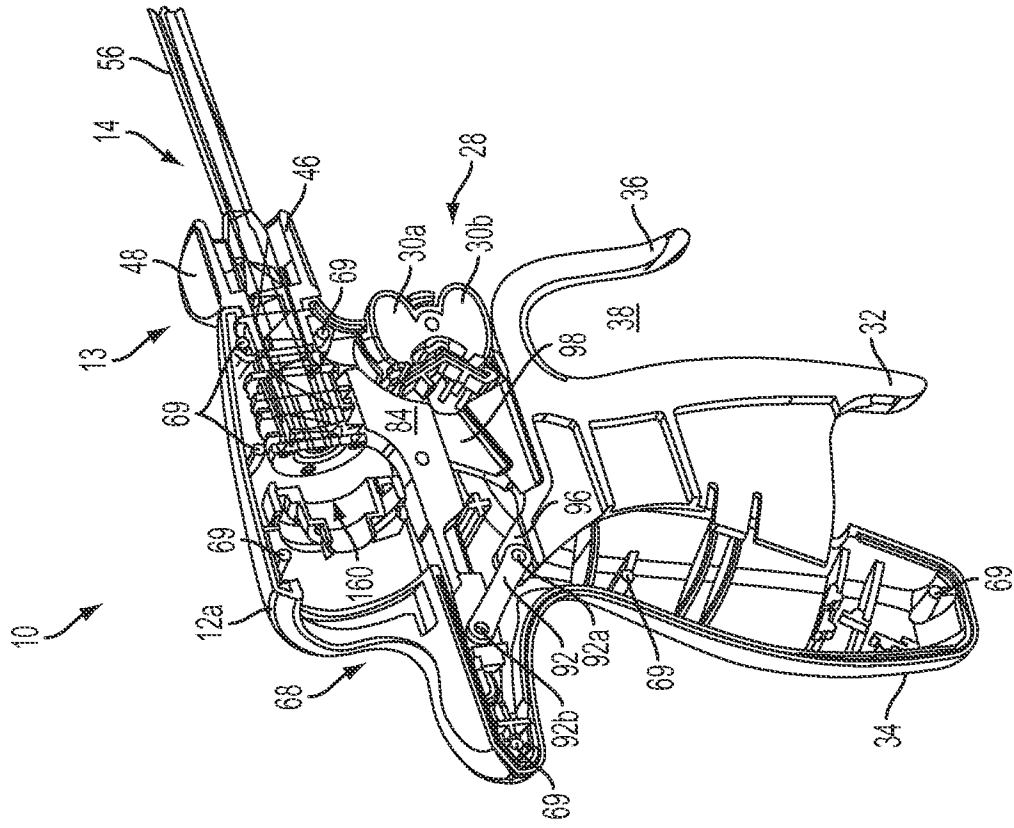

FIG. 7

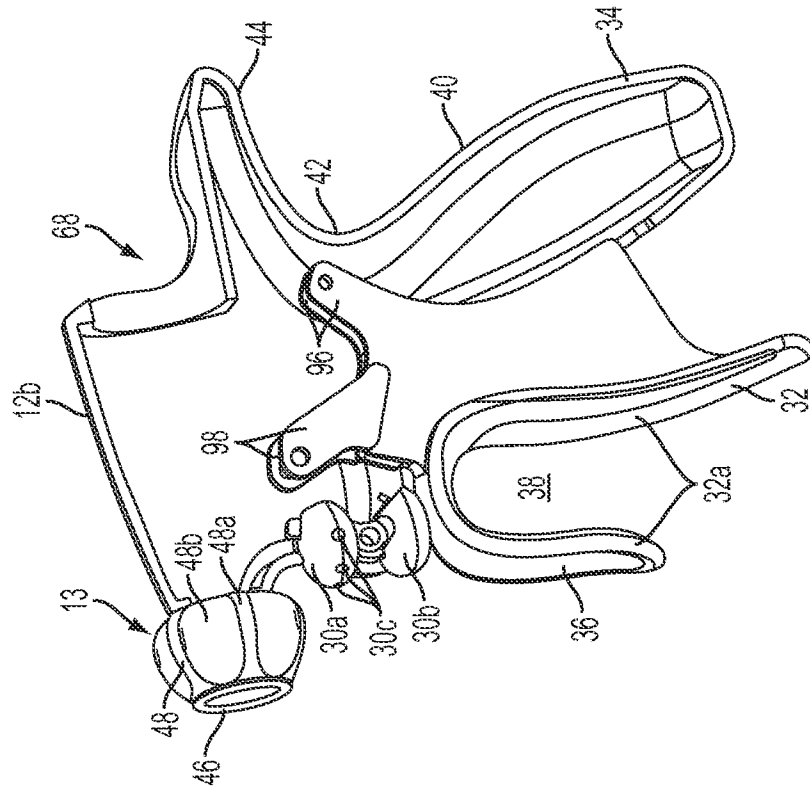

FIG. 6

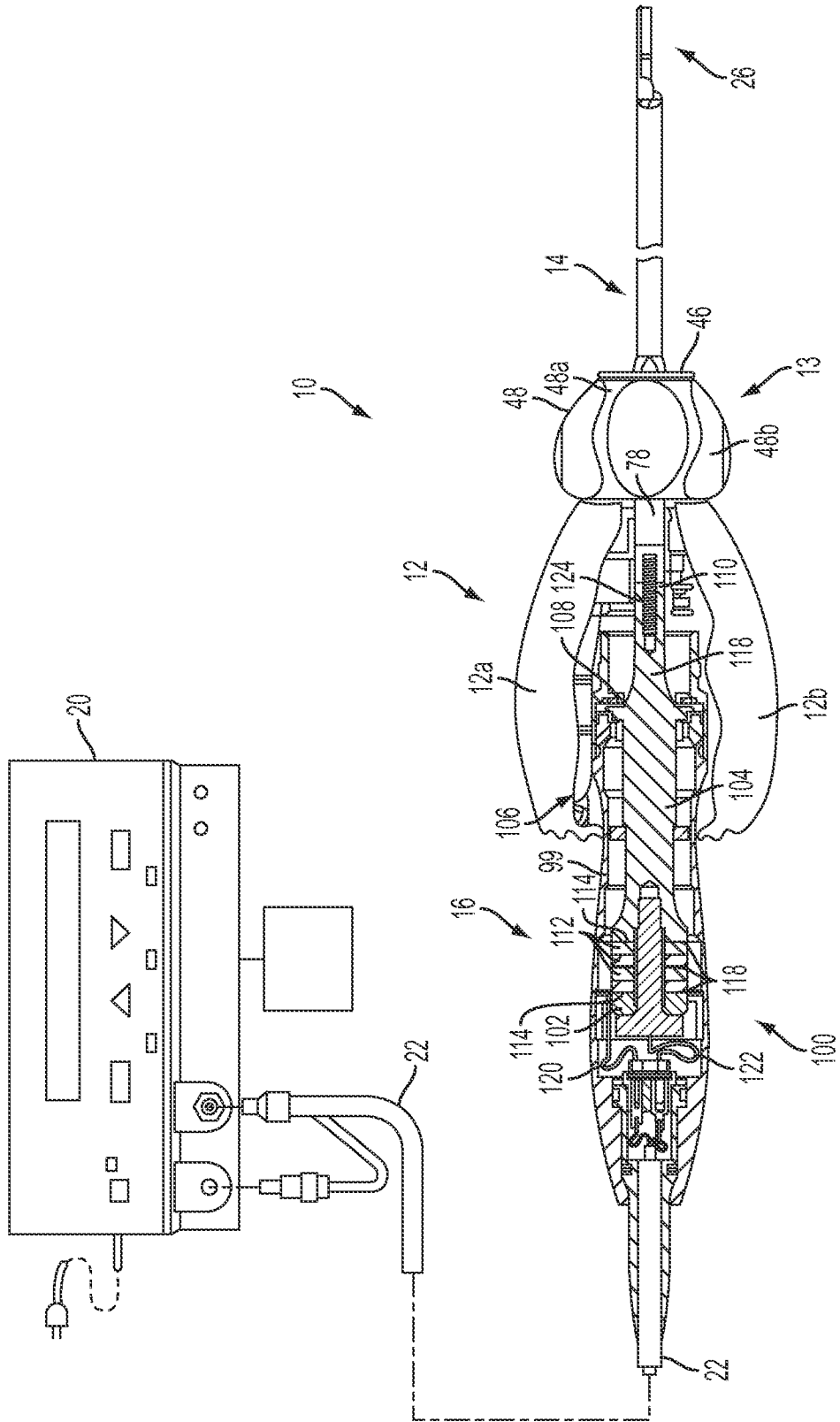

FIG. 8

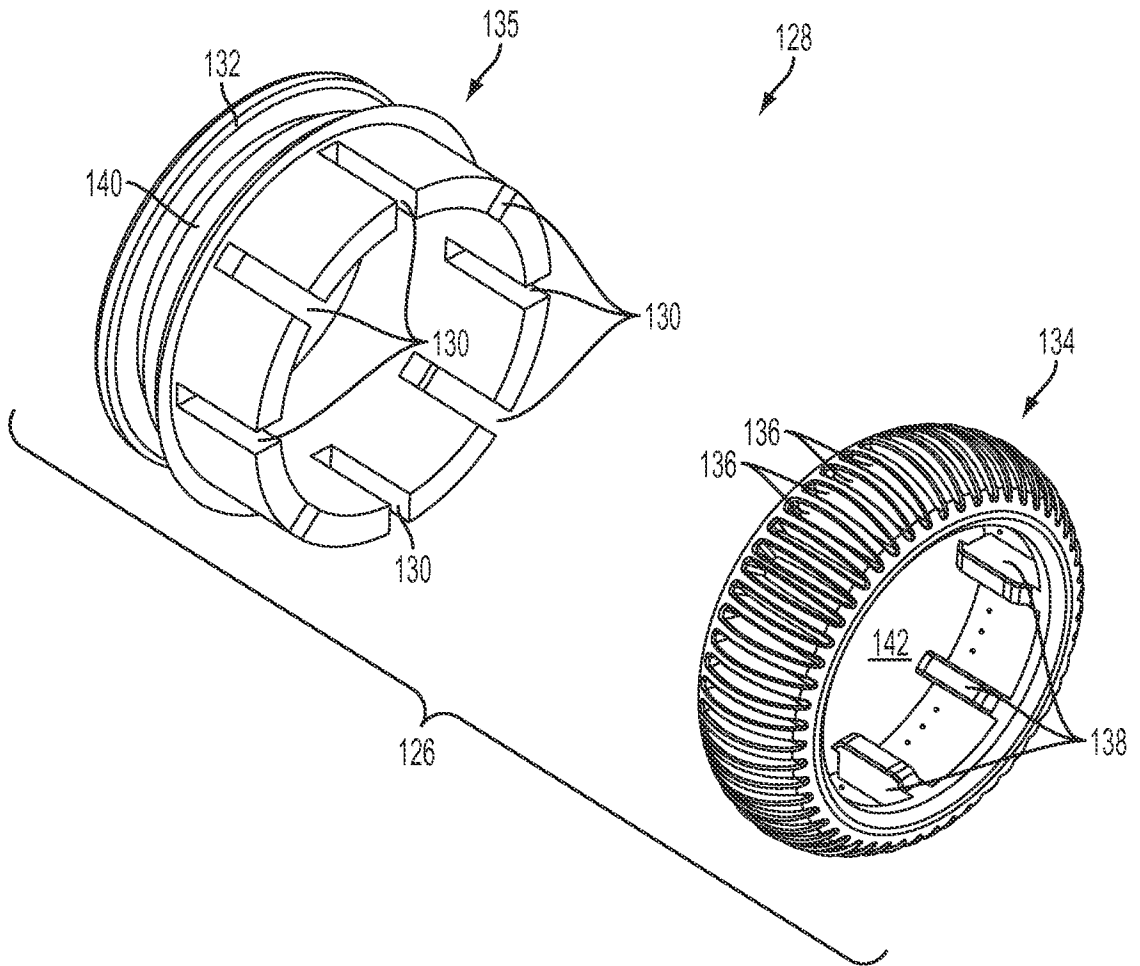

FIG. 9

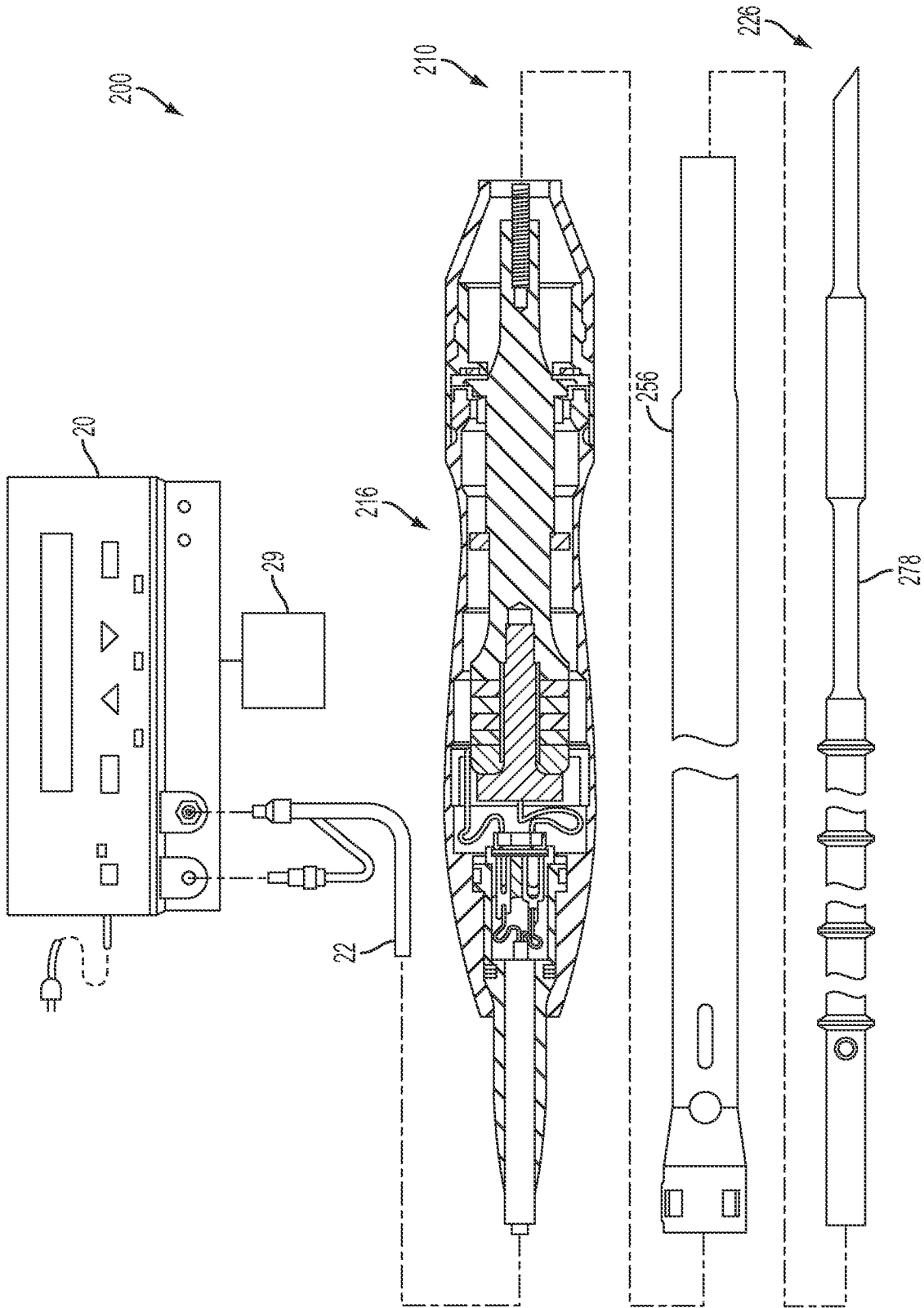

FIG. 10

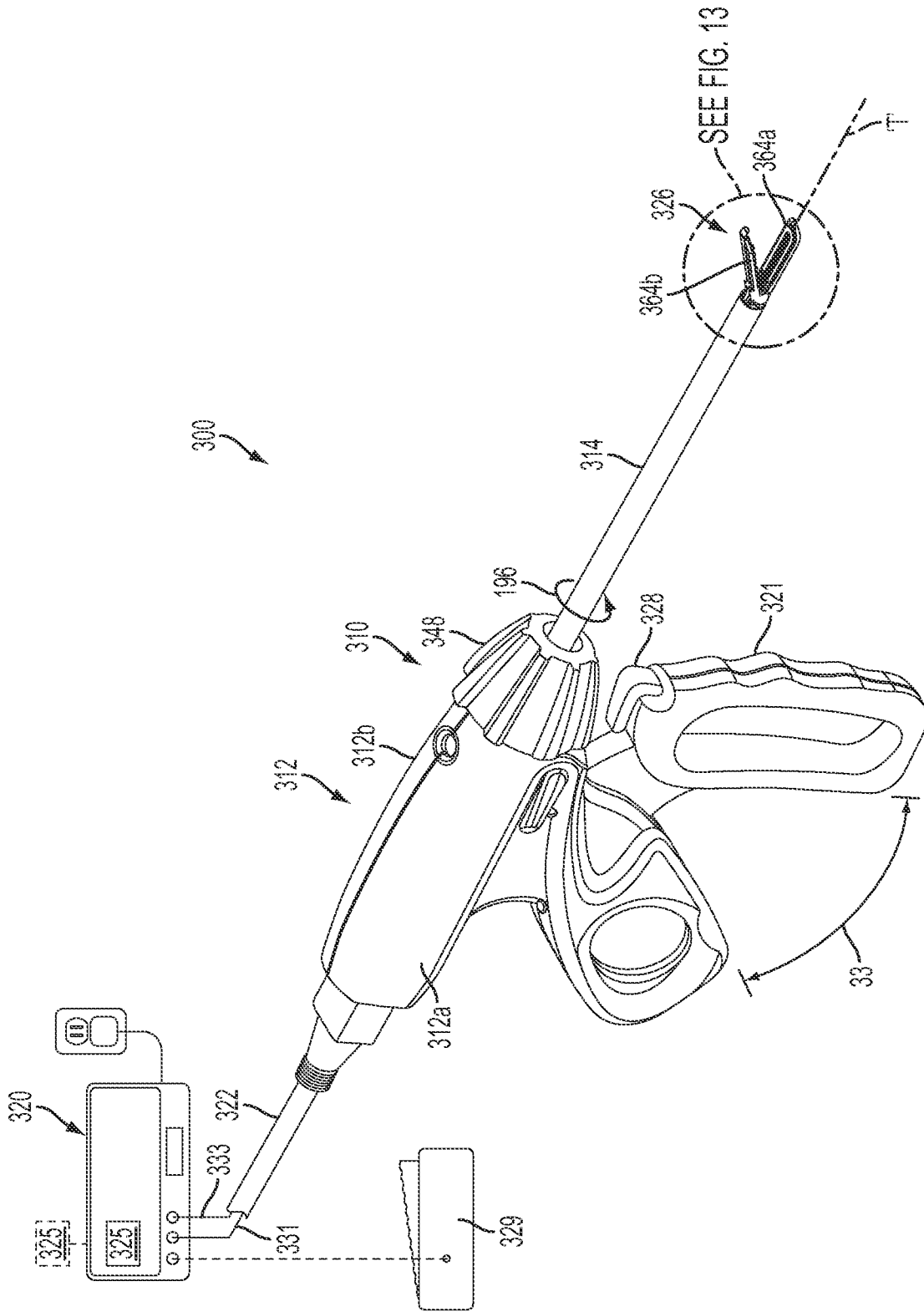

FIG. 11

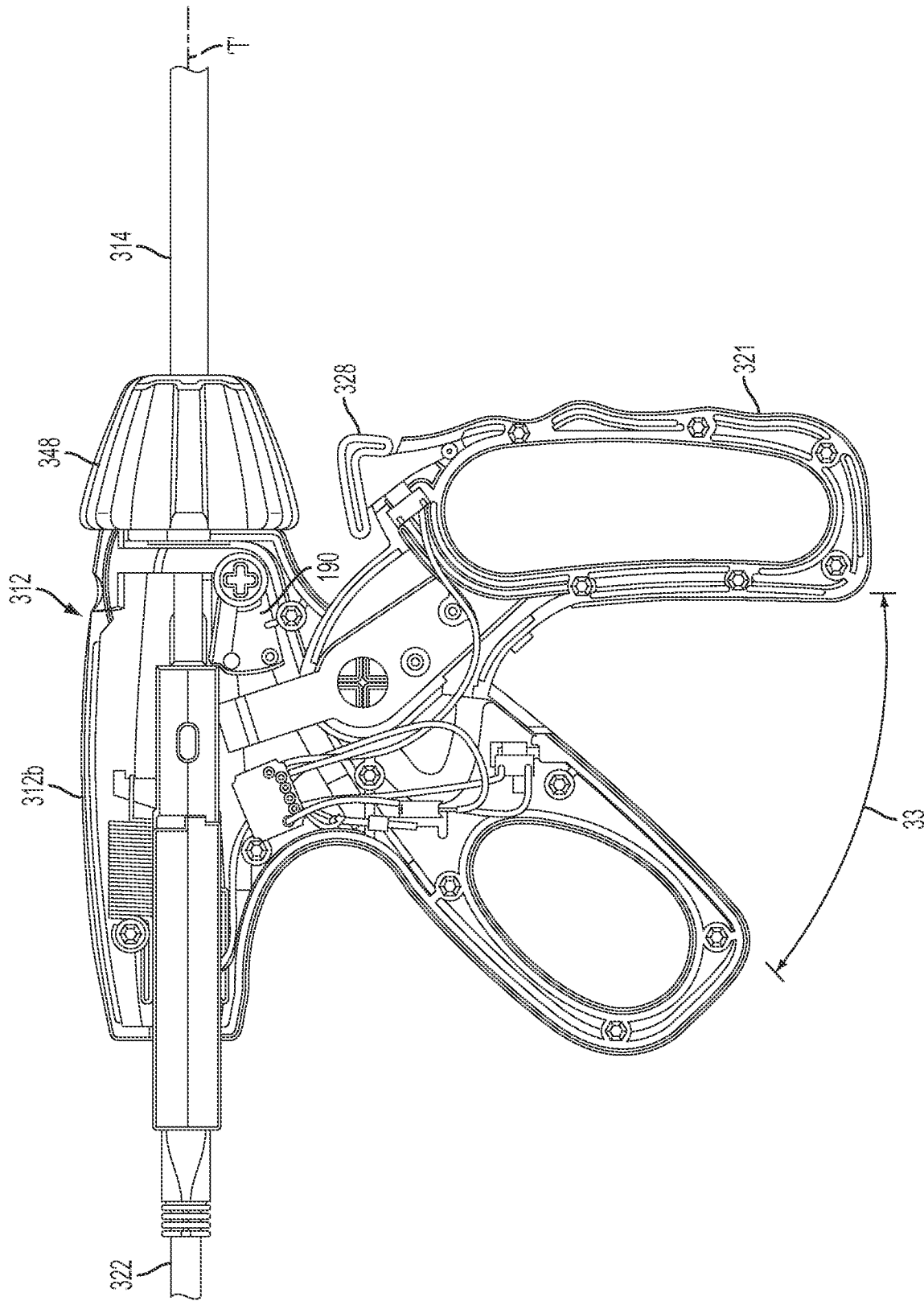

FIG. 12

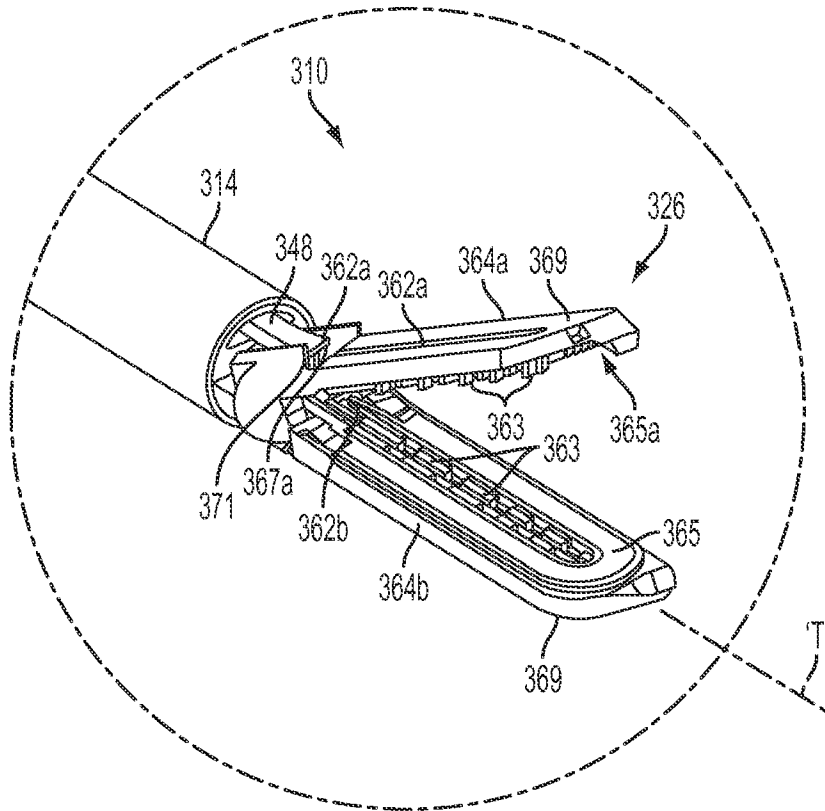

FIG. 13

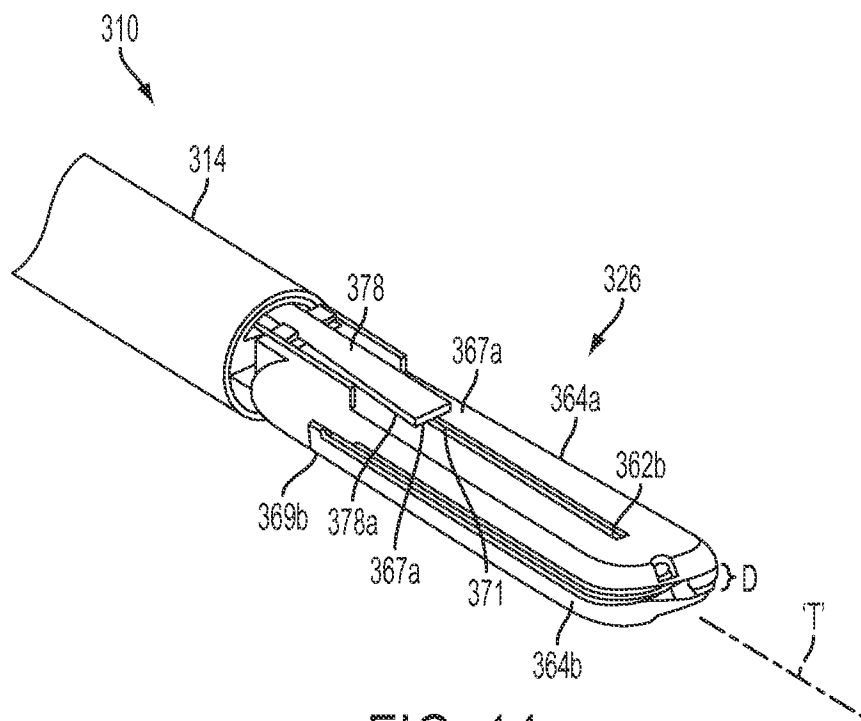

FIG. 14

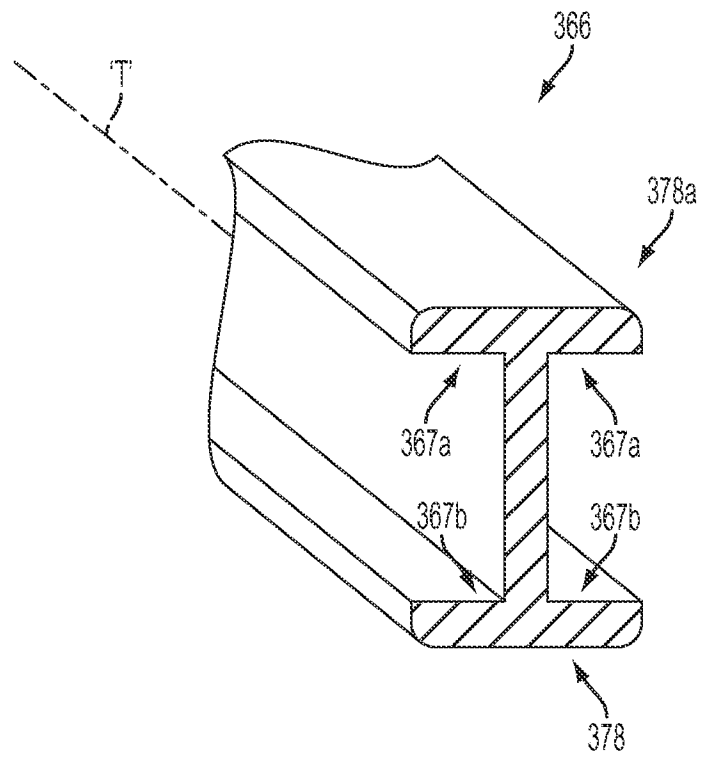

FIG. 15

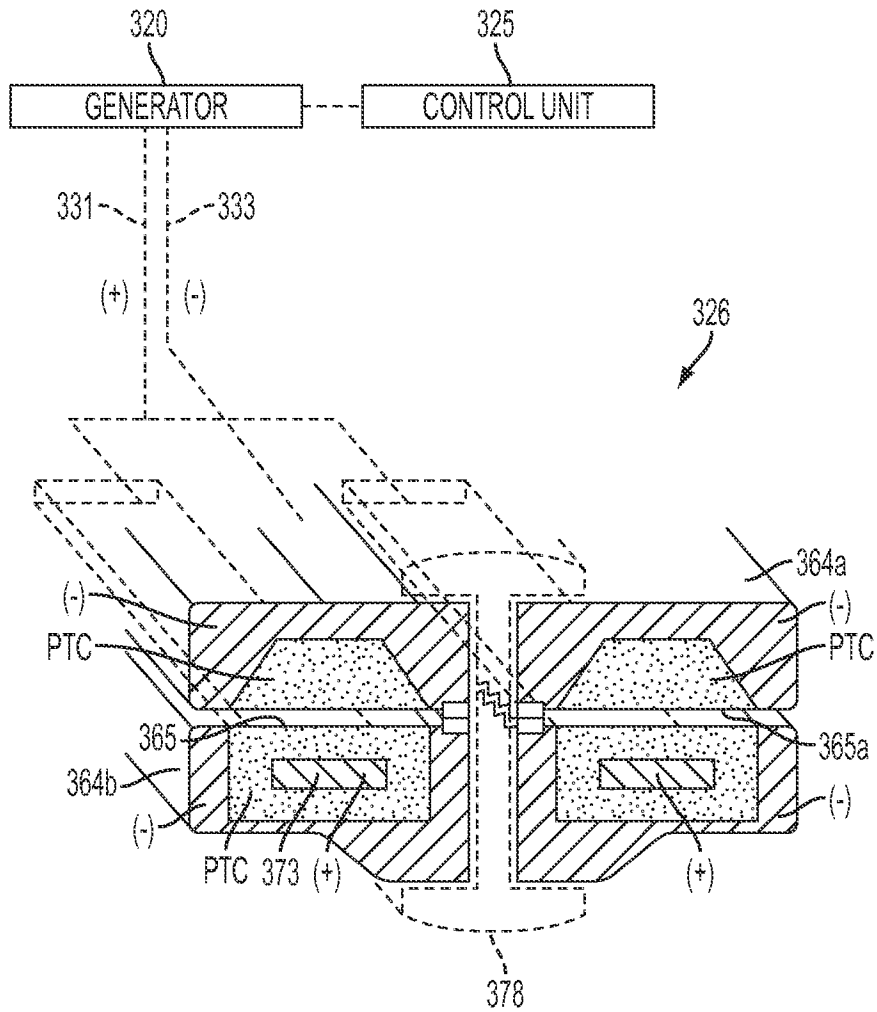

FIG. 16

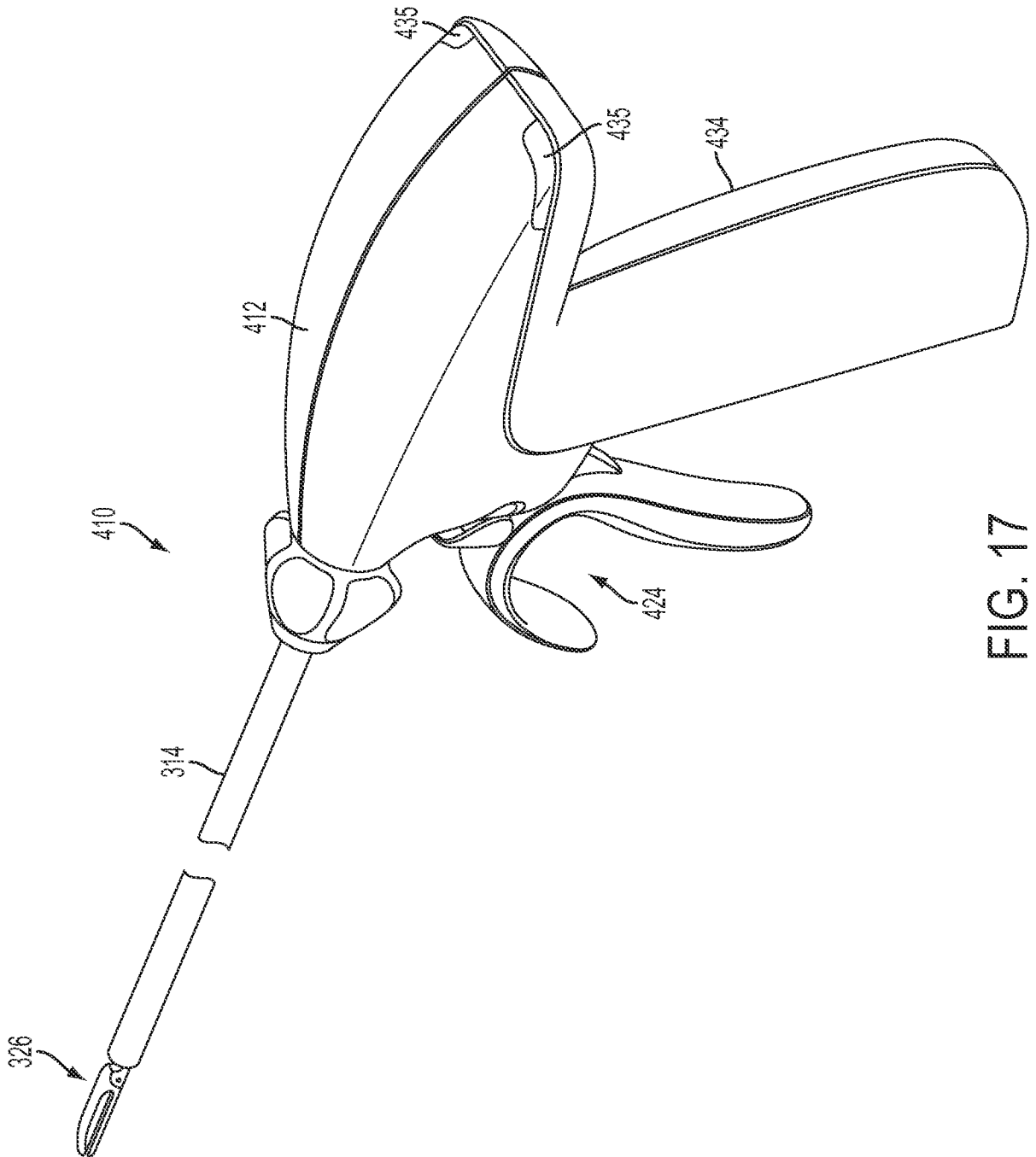

FIG. 17

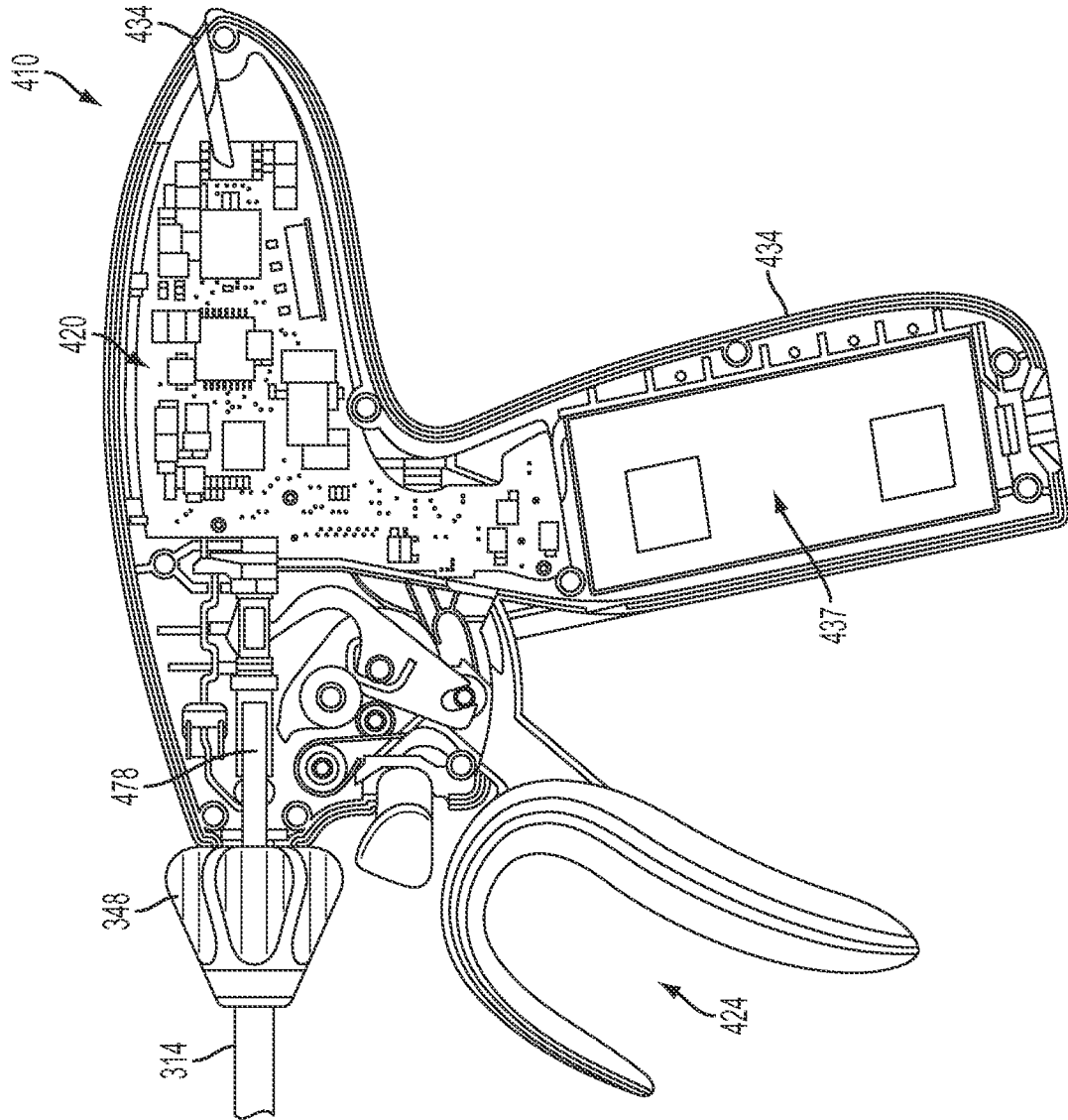

FIG. 18A

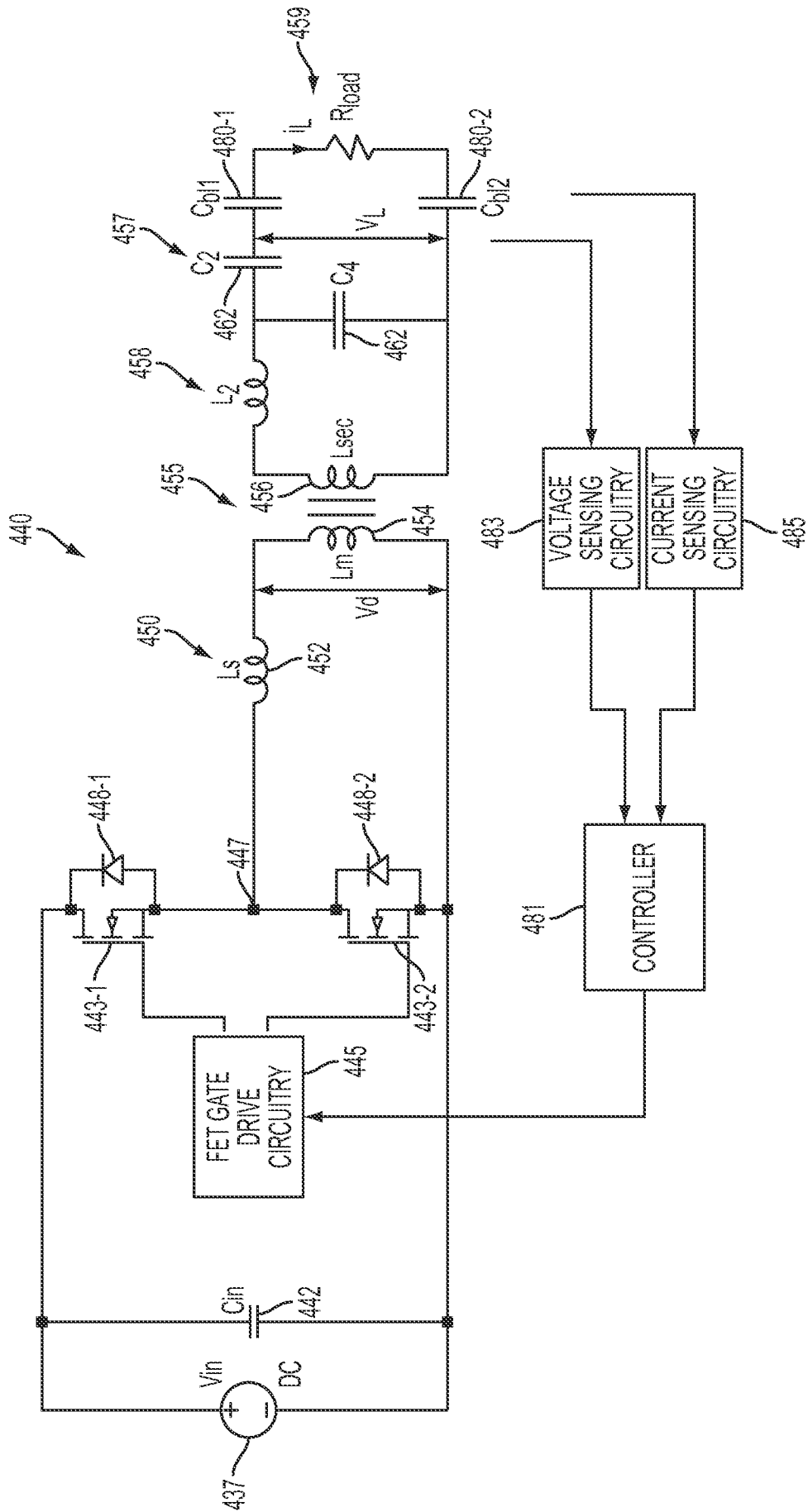

FIG. 18B

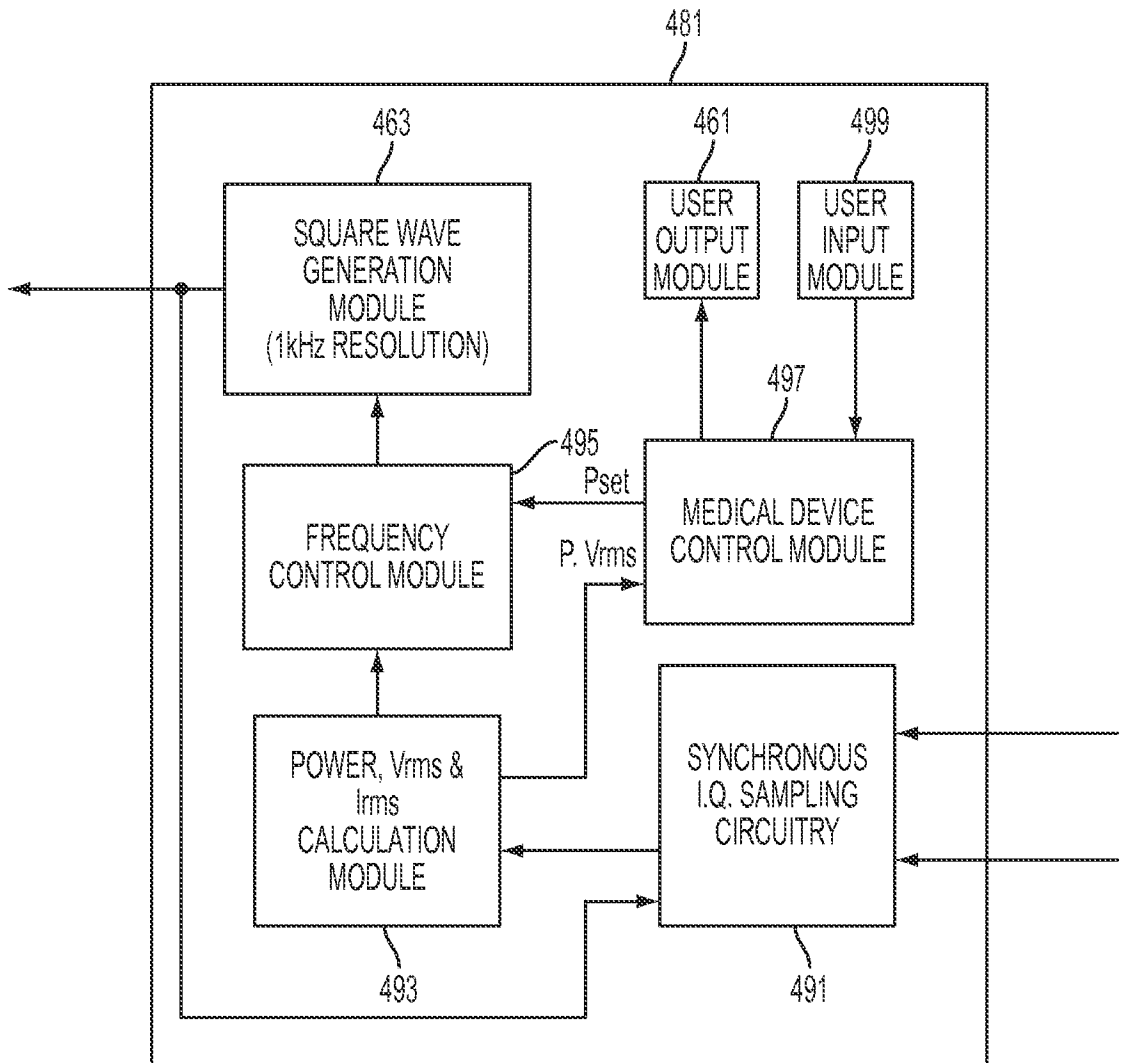

FIG. 18C

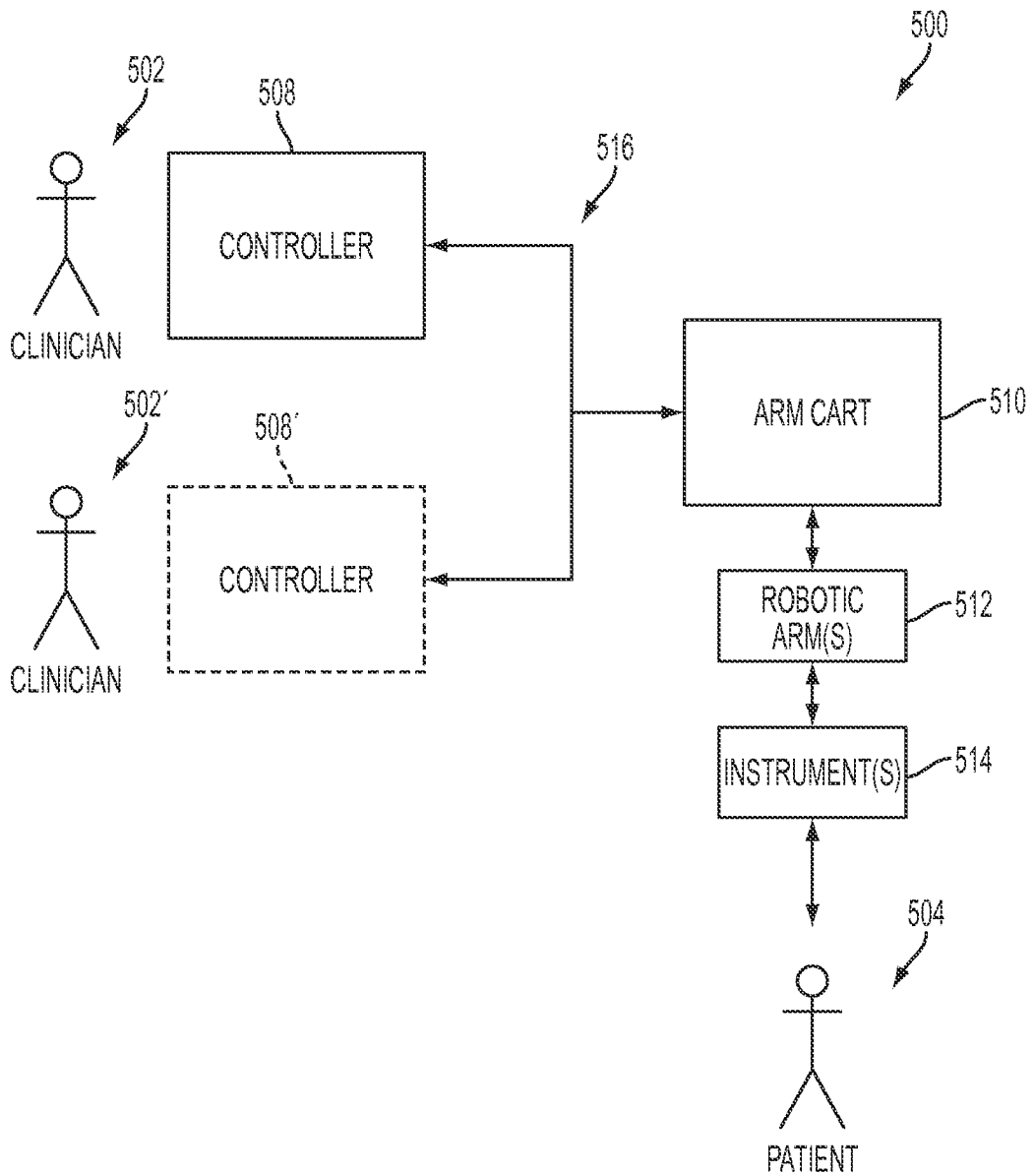

FIG. 19

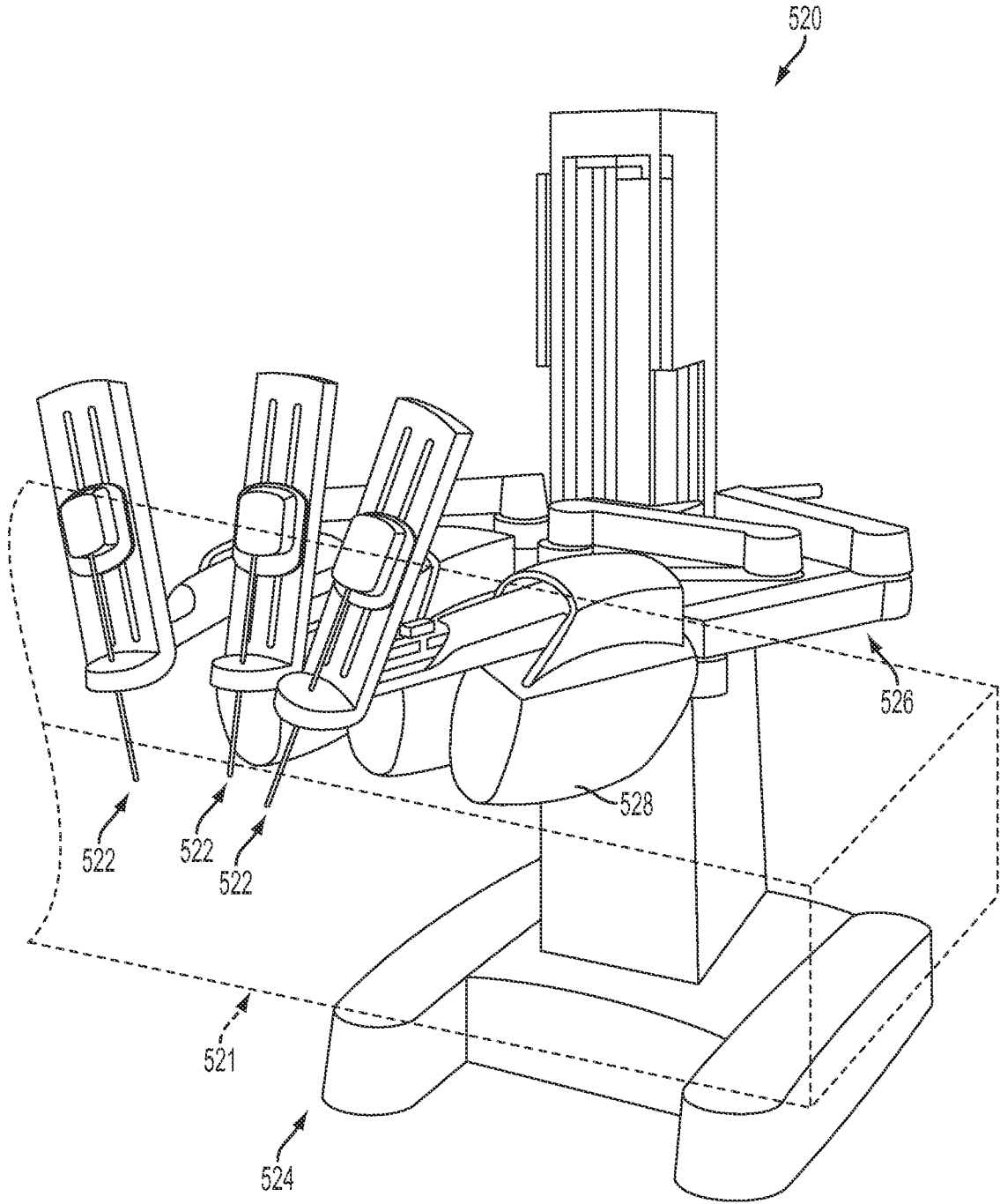

FIG. 20

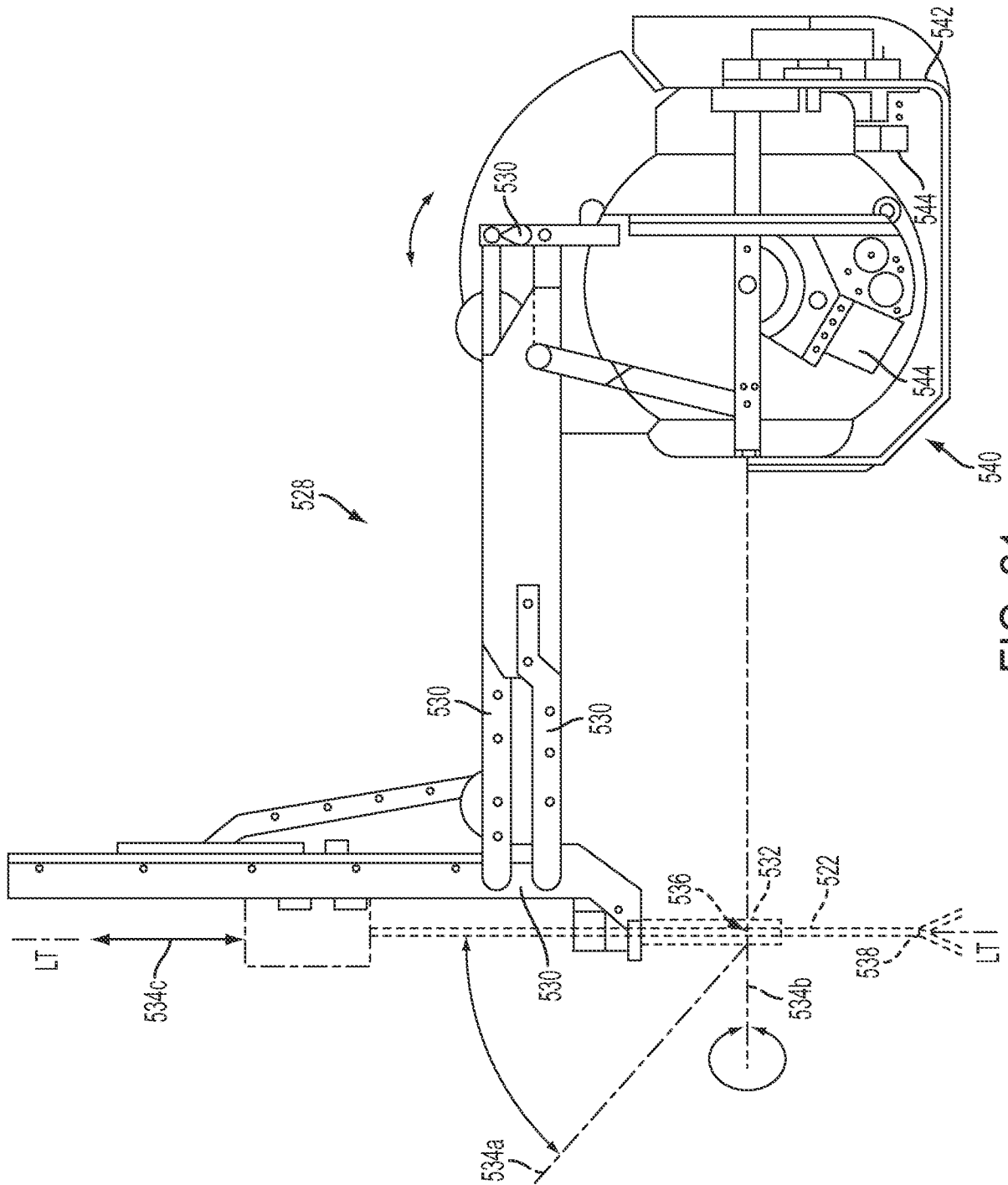

FIG. 21

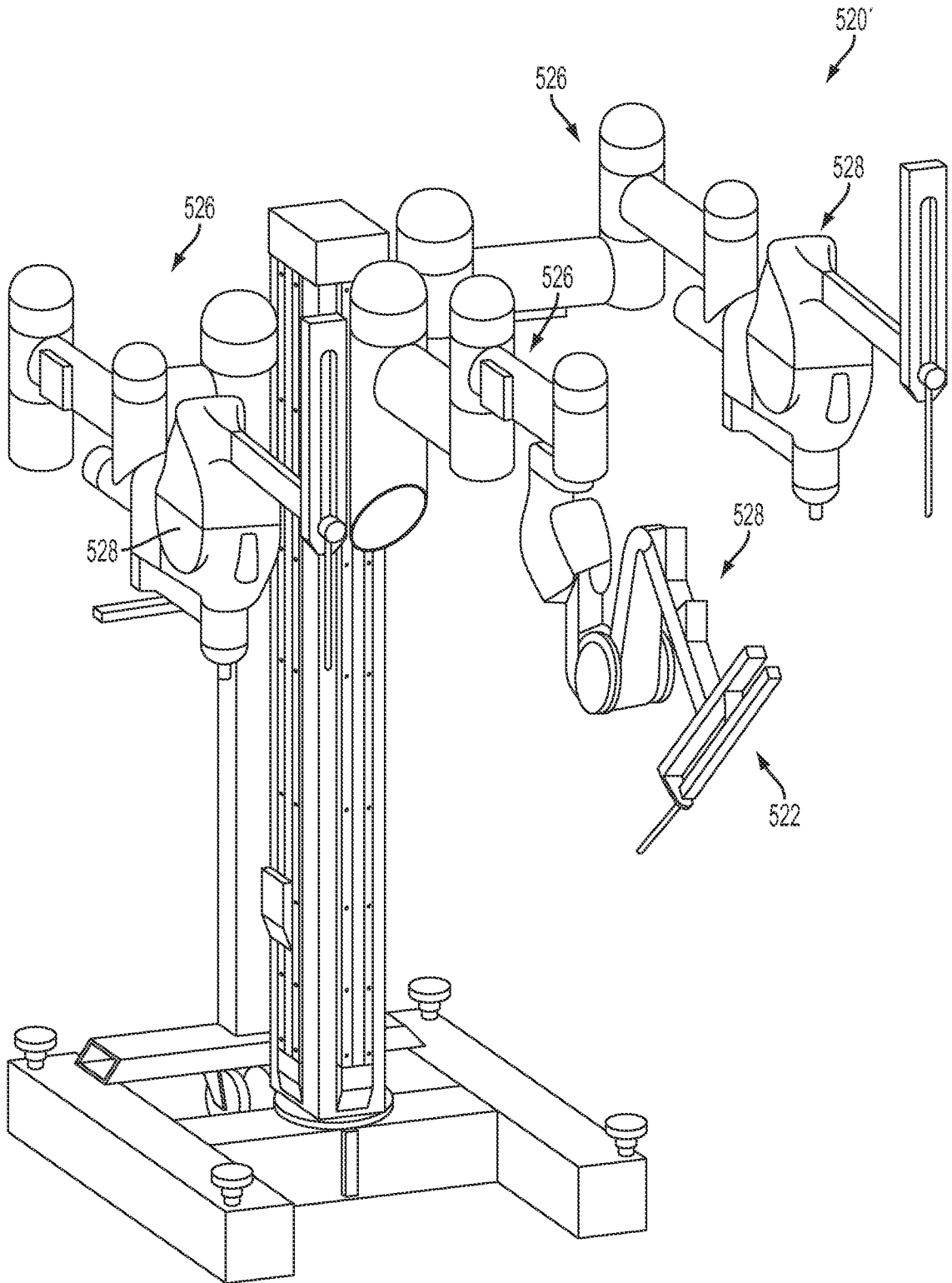

FIG. 22

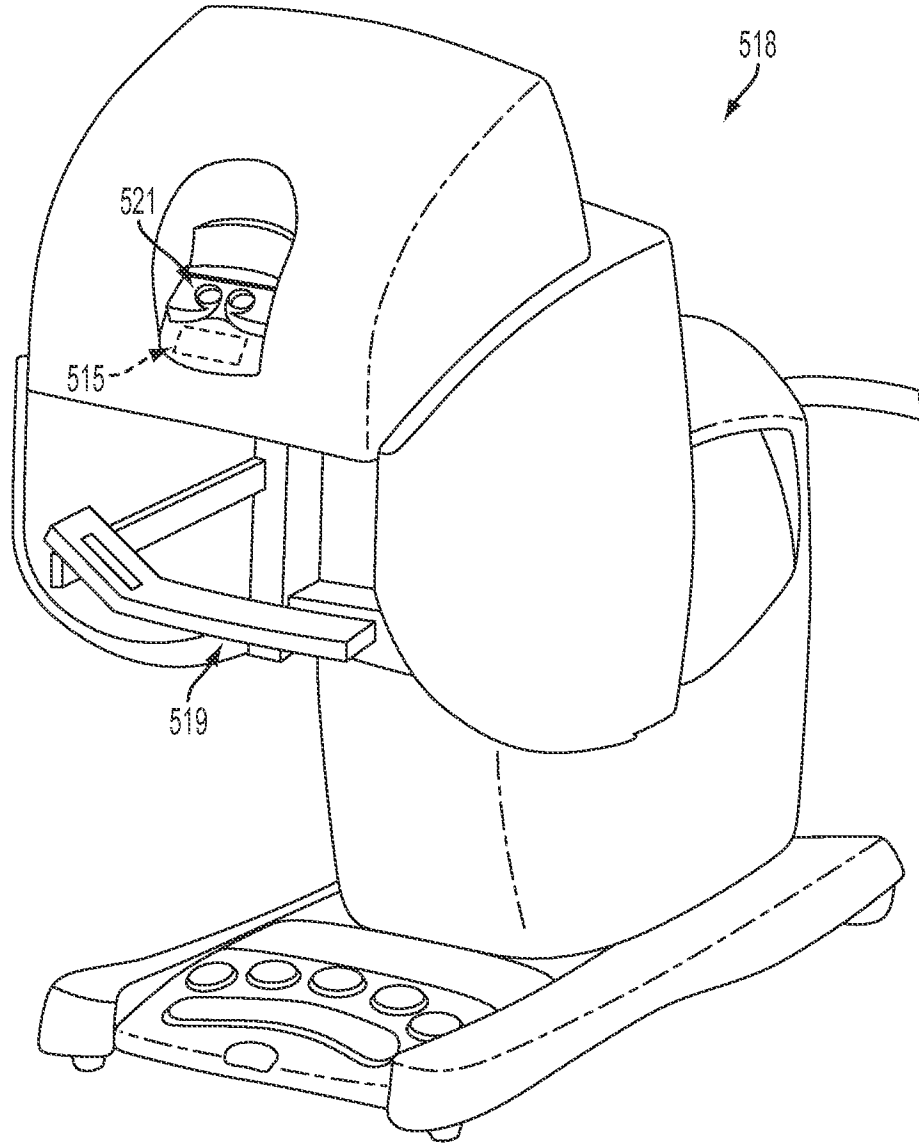

FIG. 23

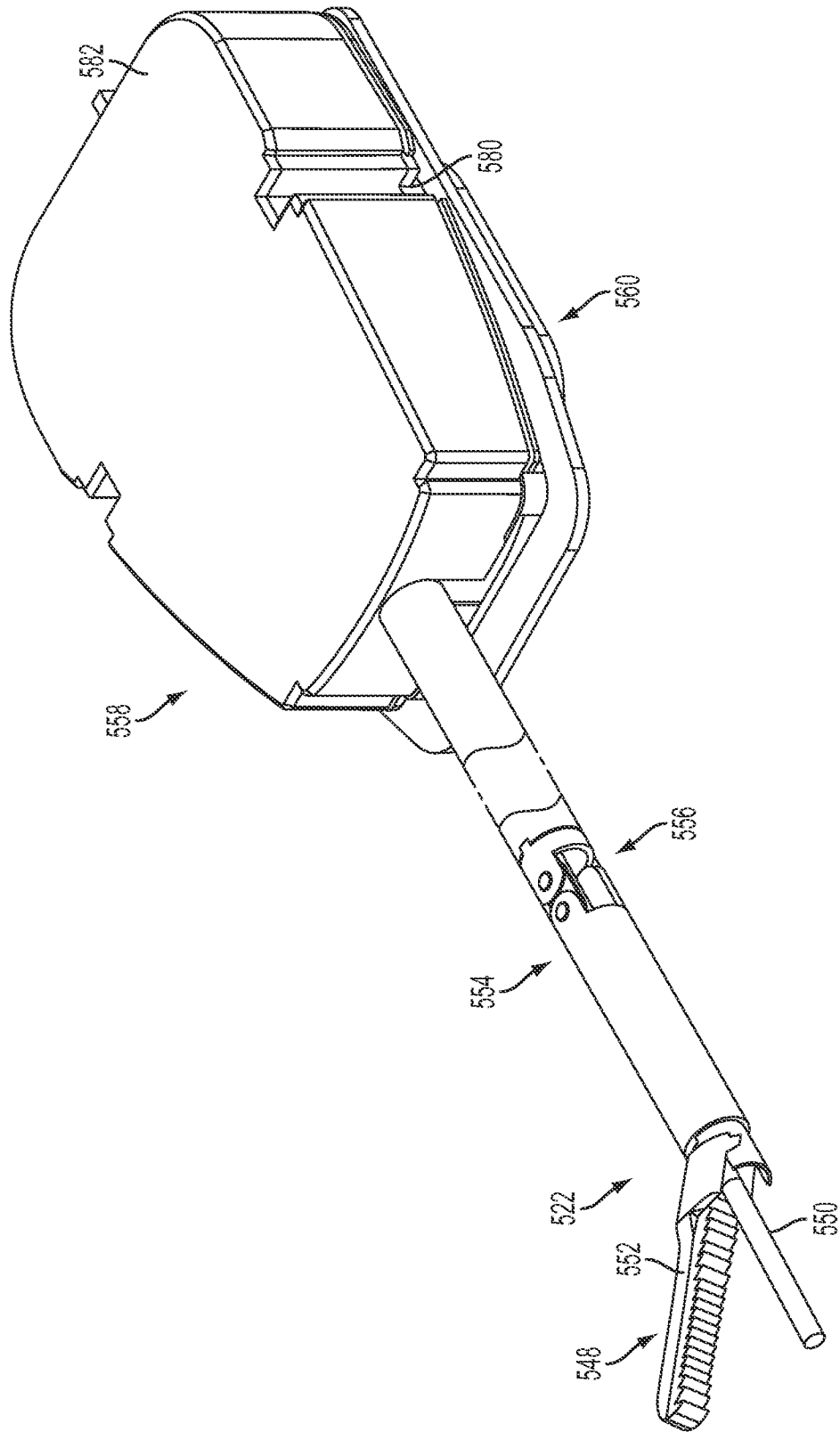

FIG. 24

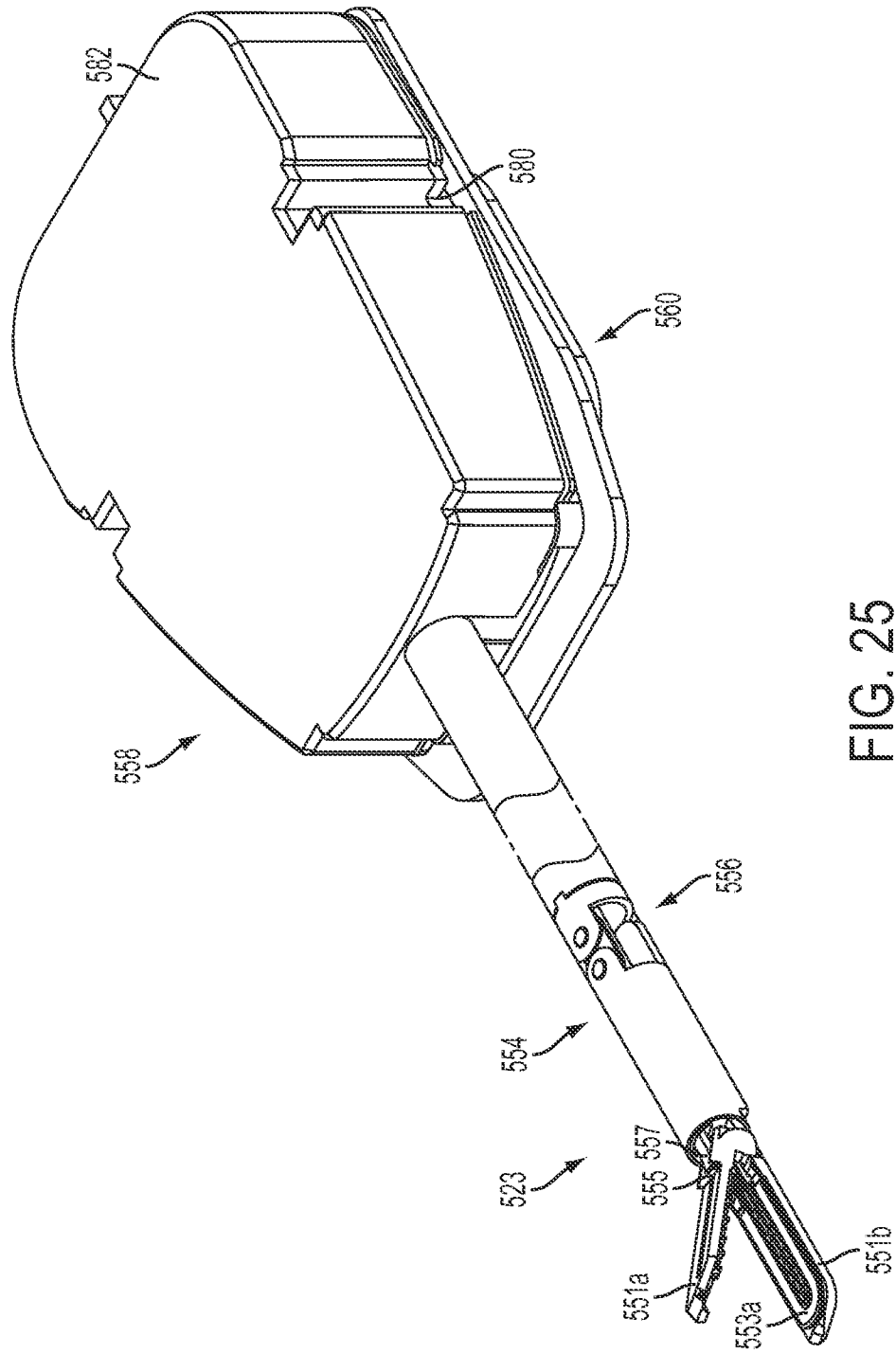

FIG. 25

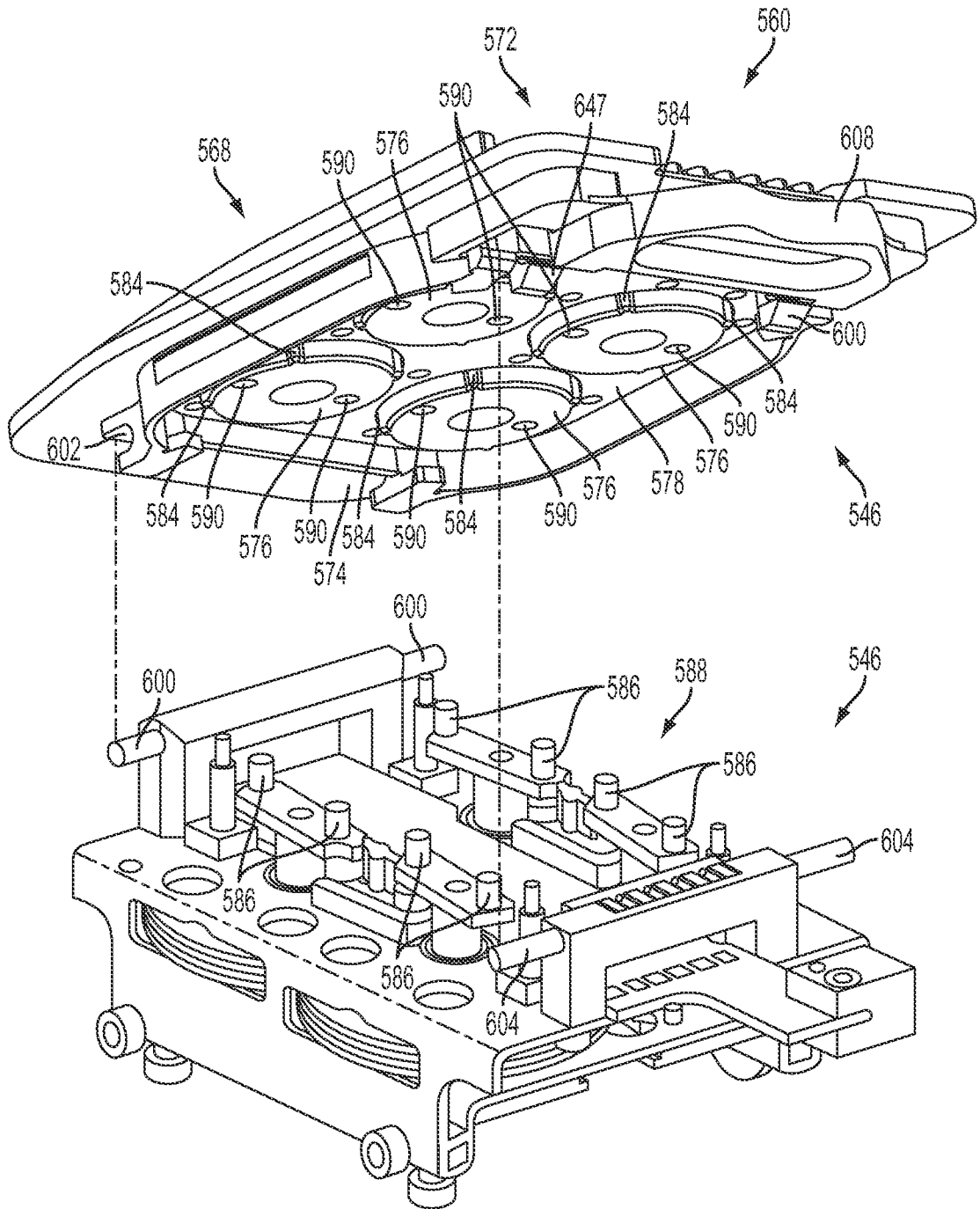

FIG. 26

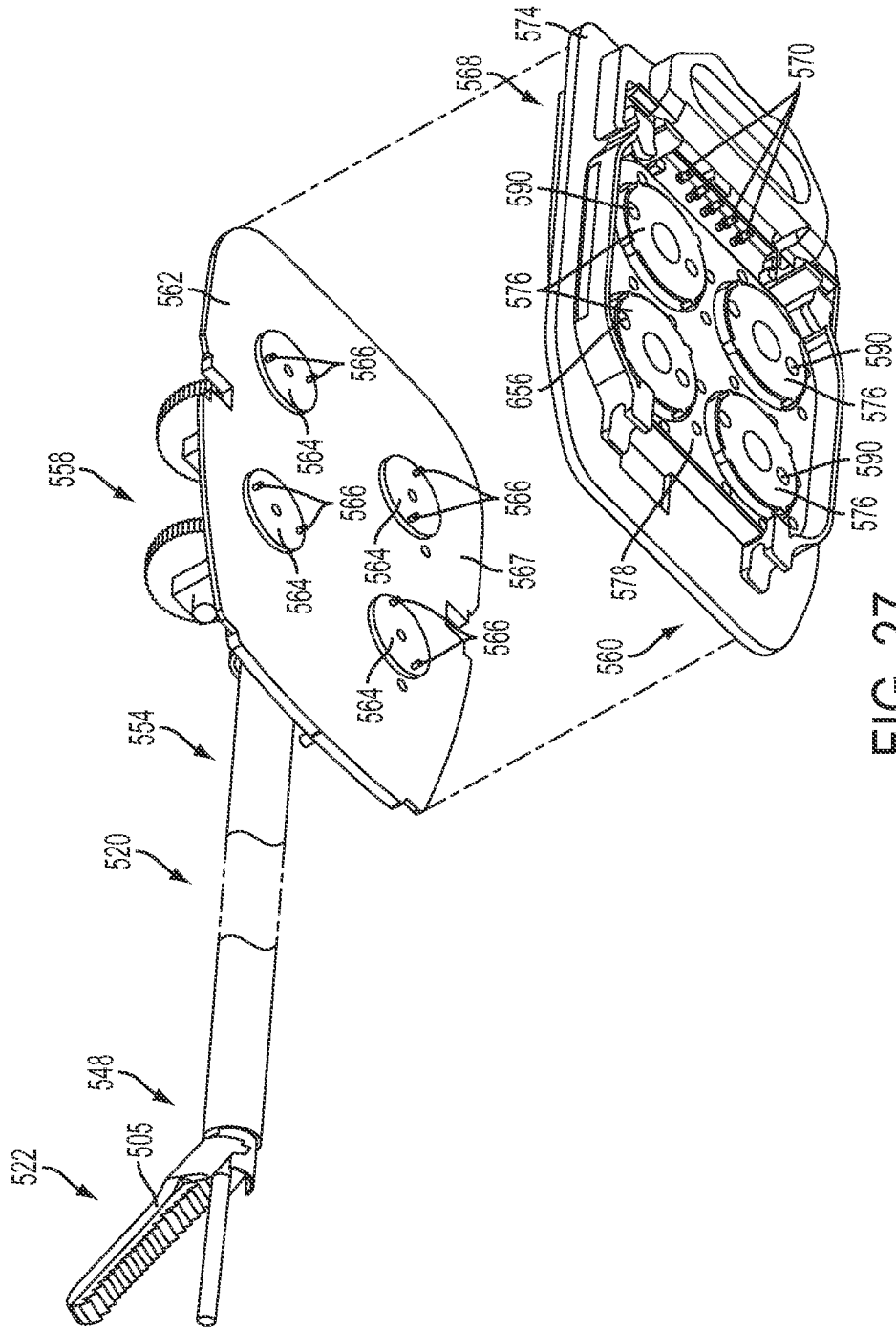

FIG. 27

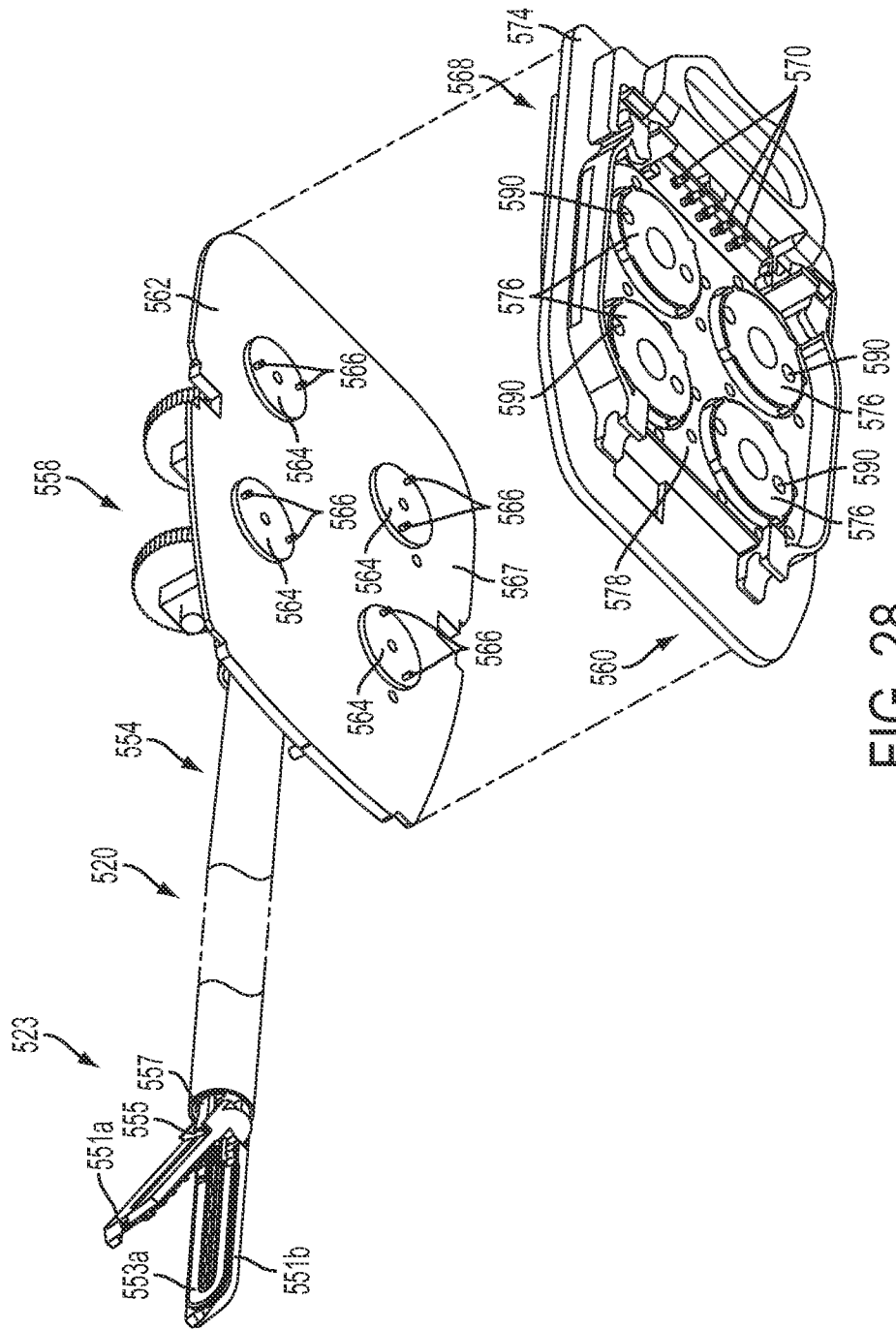
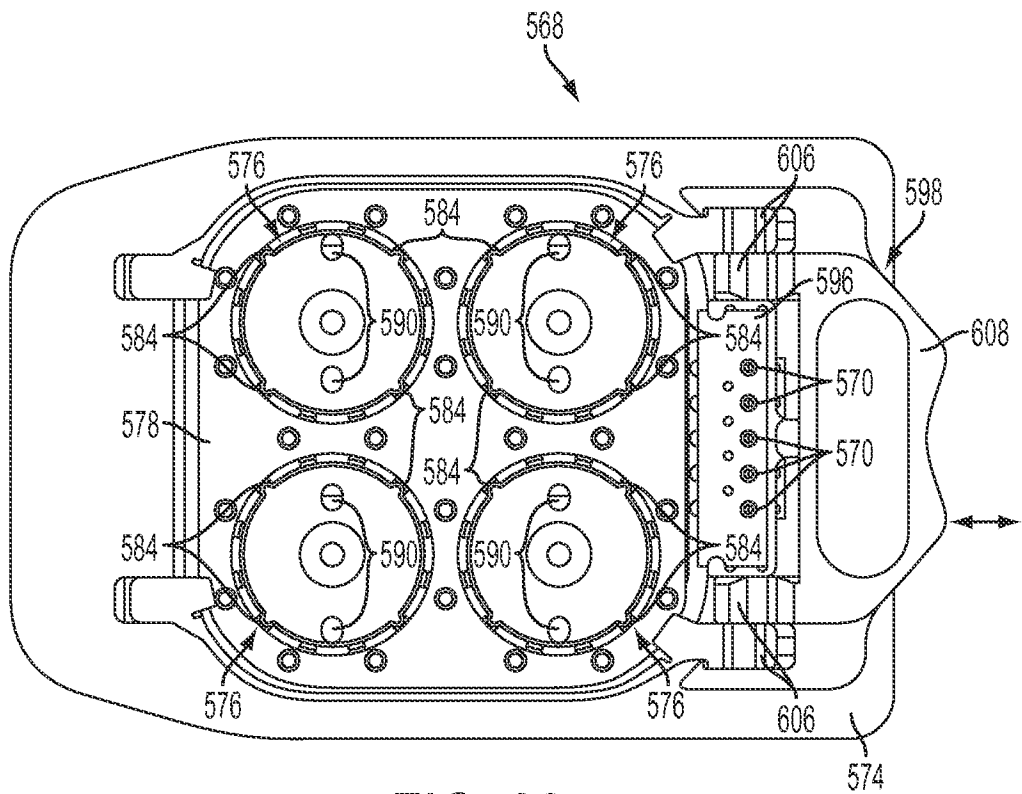
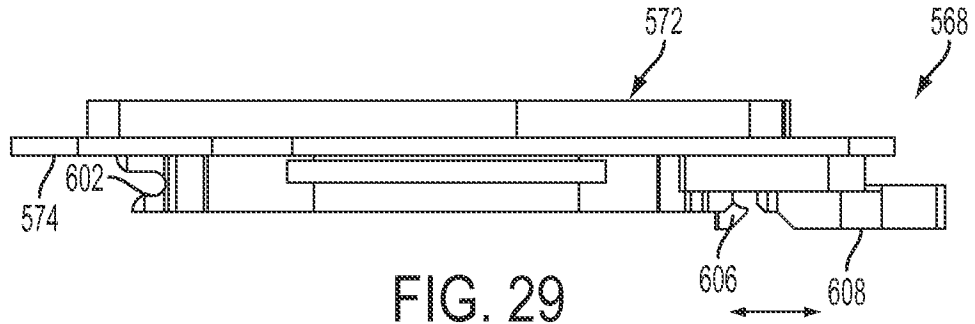

FIG. 28



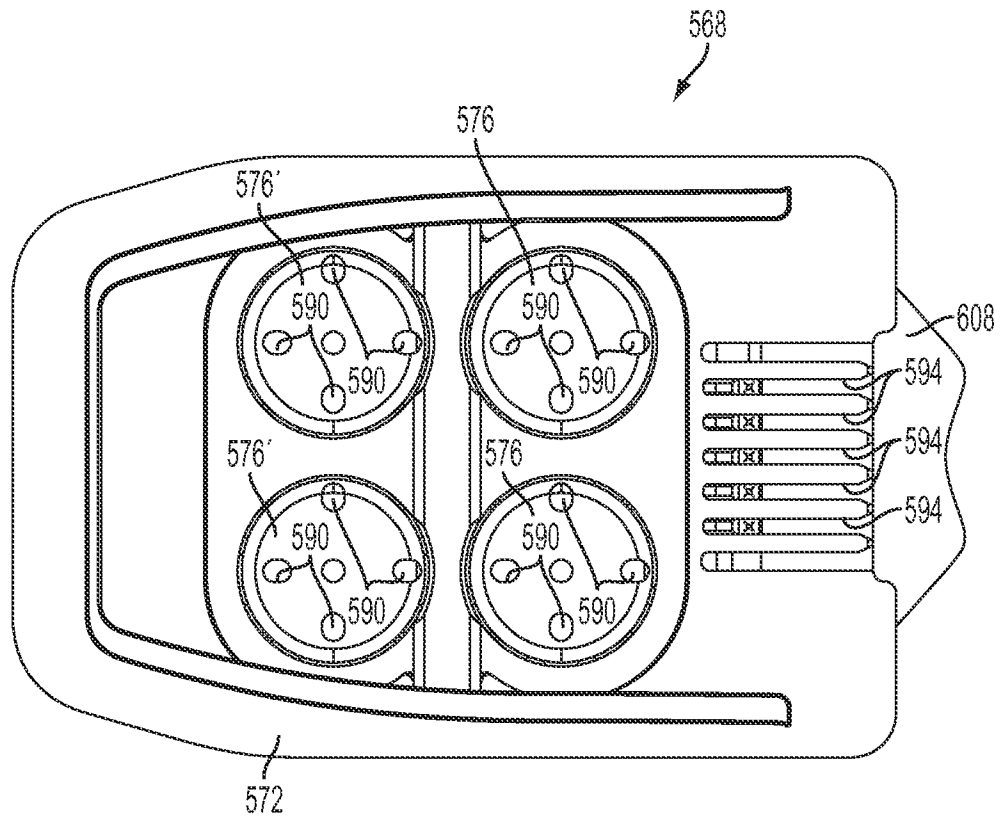

FIG. 31

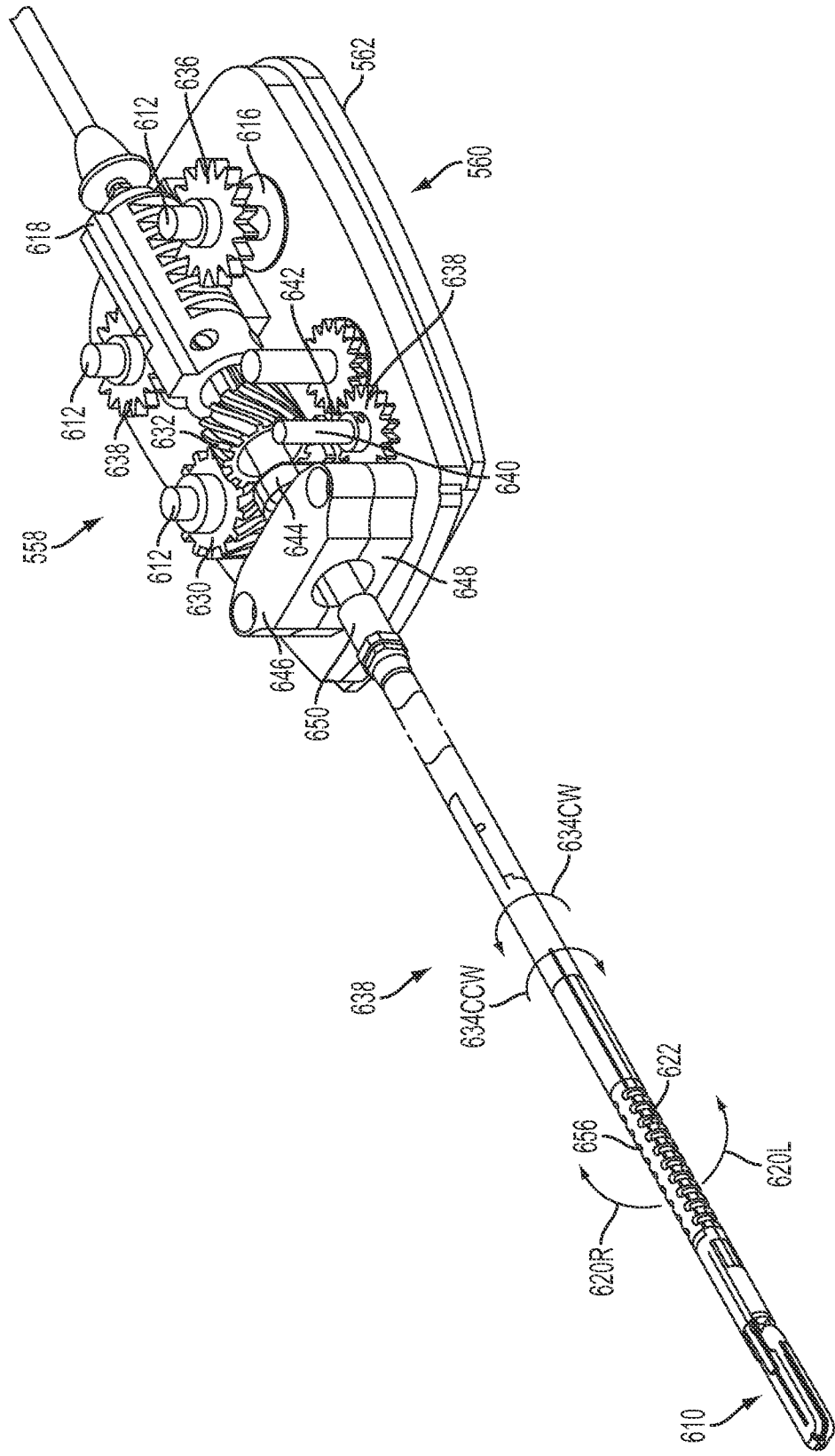

FIG. 32

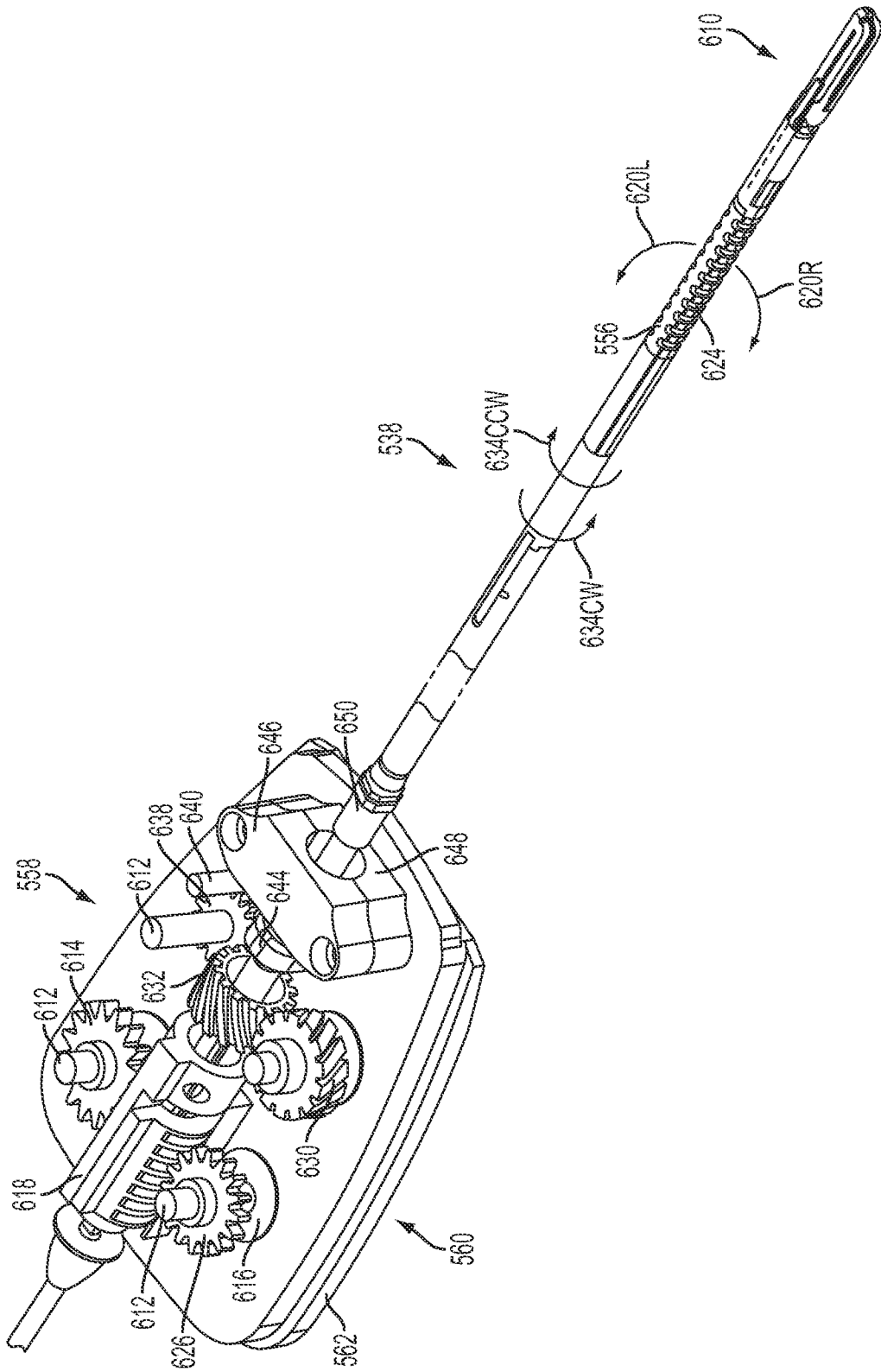

FIG. 33

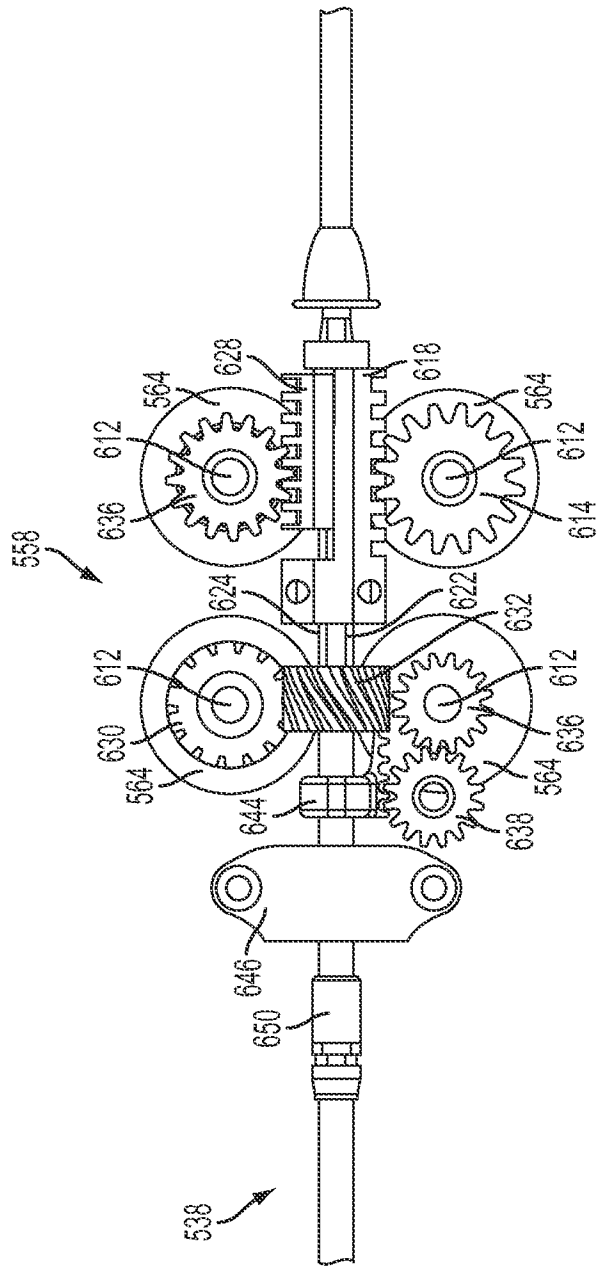

FIG. 34

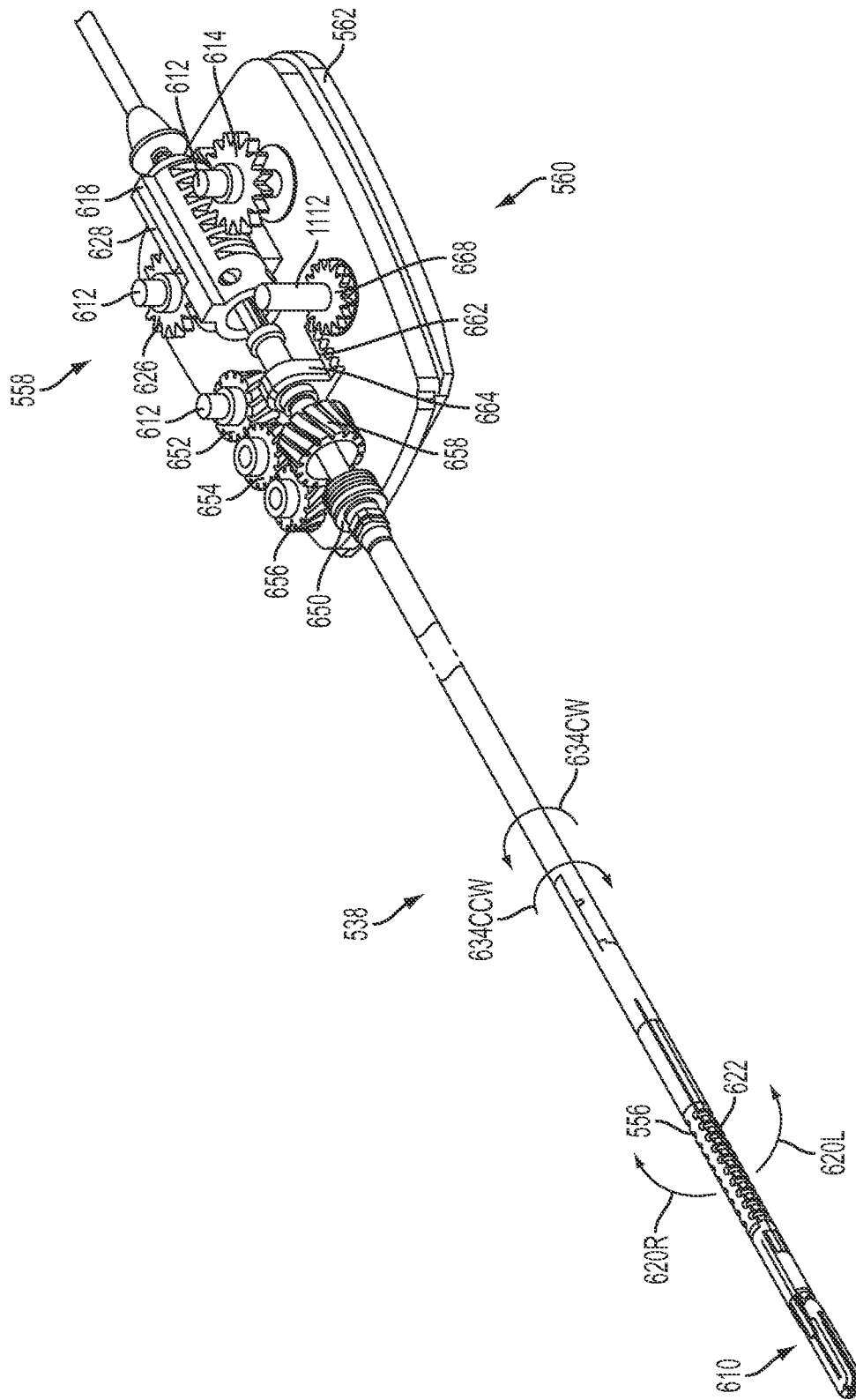

FIG. 35

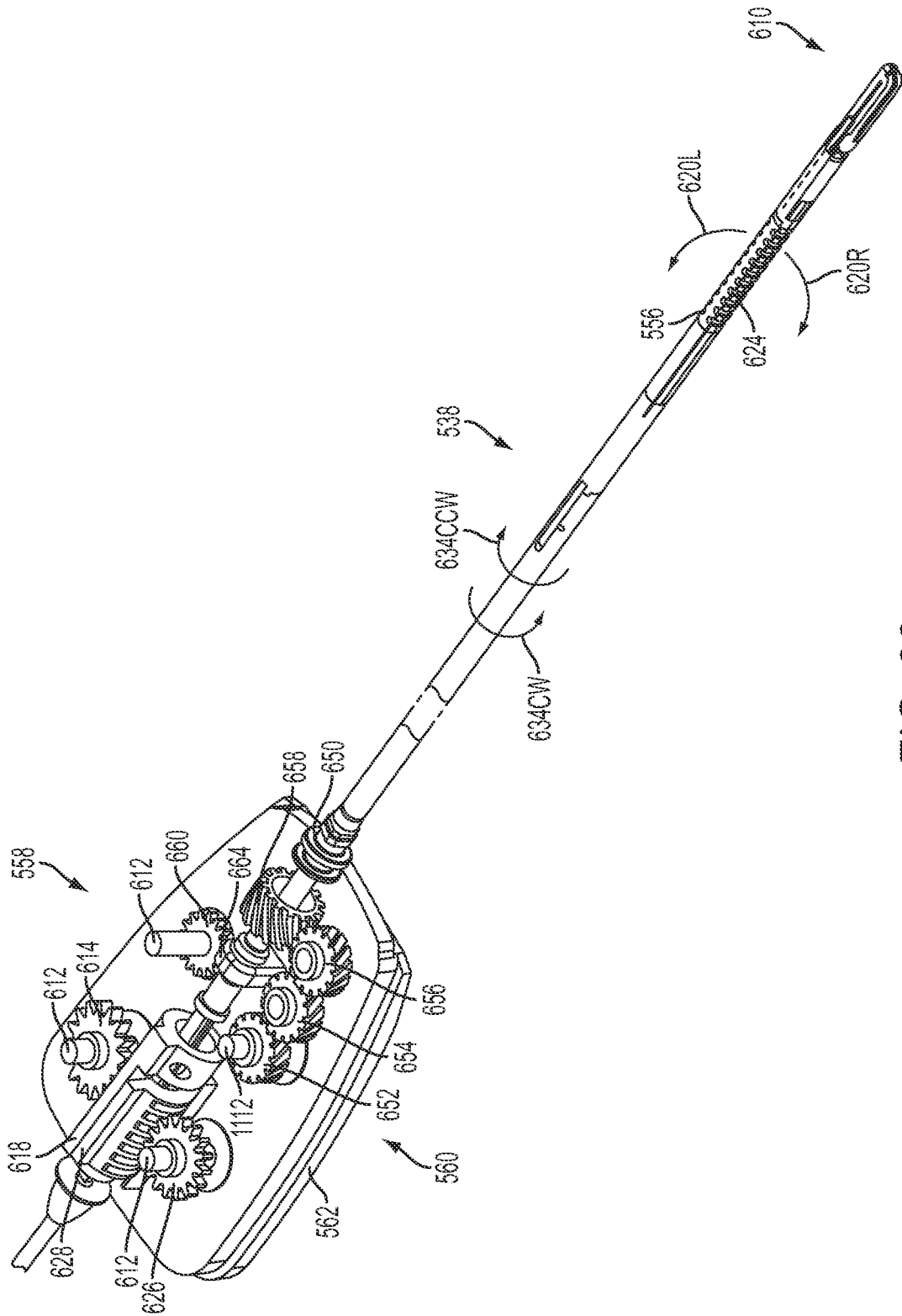

FIG. 36

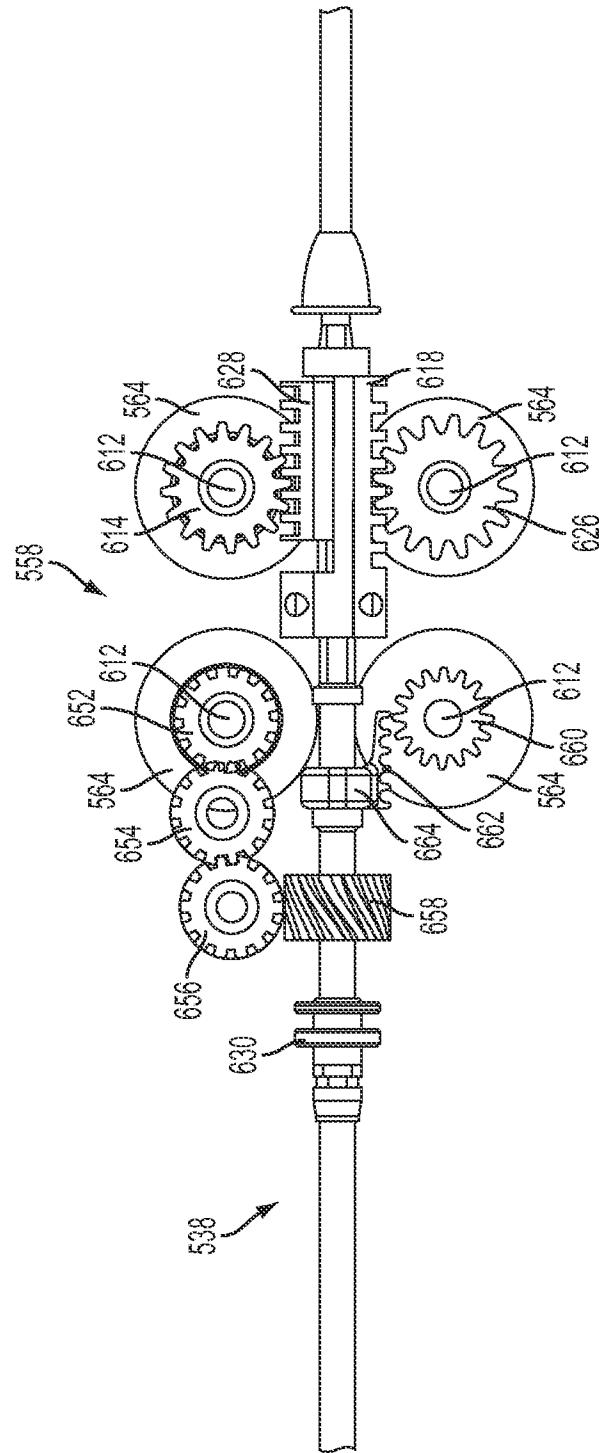

FIG. 37

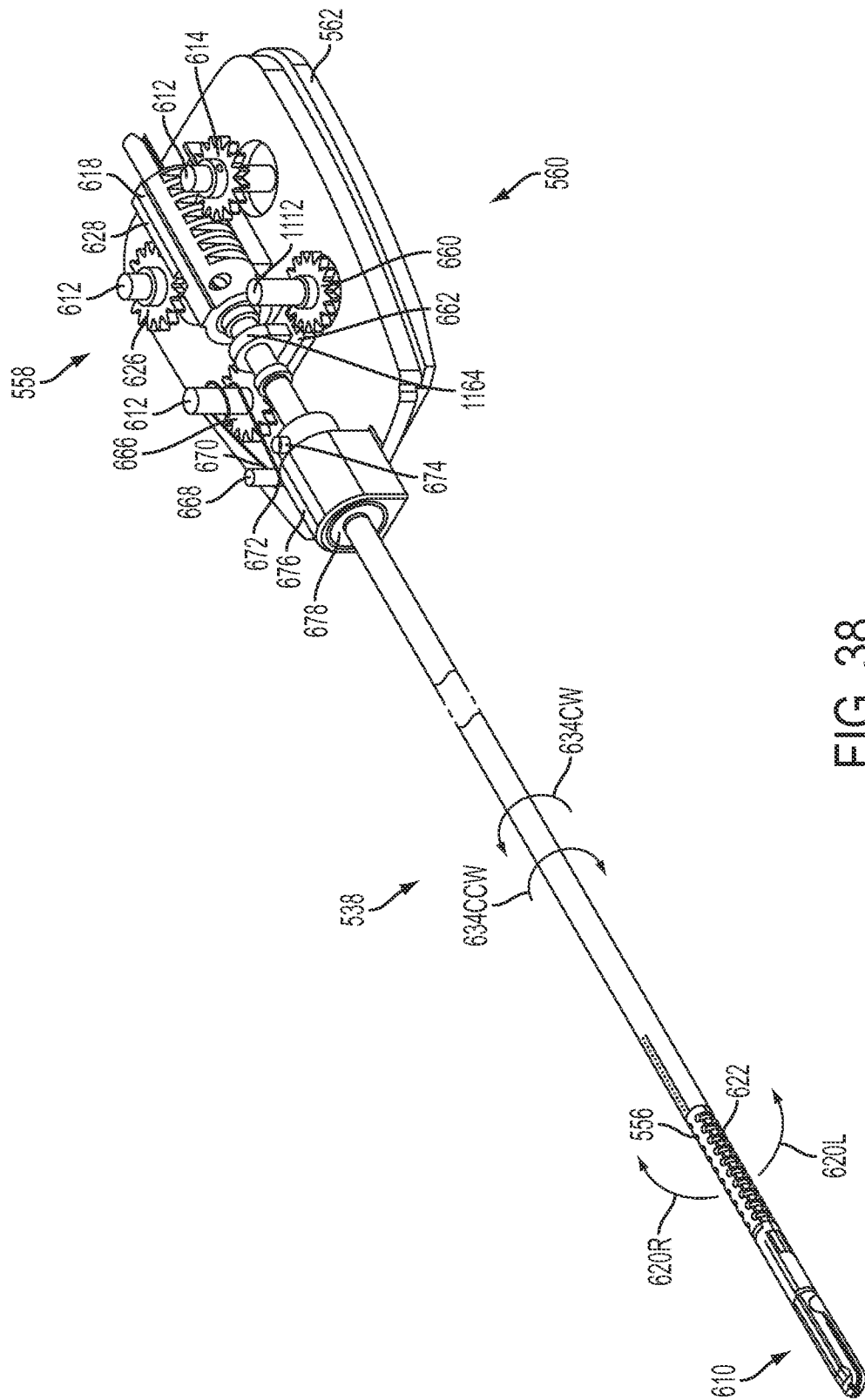

FIG. 38

37/76

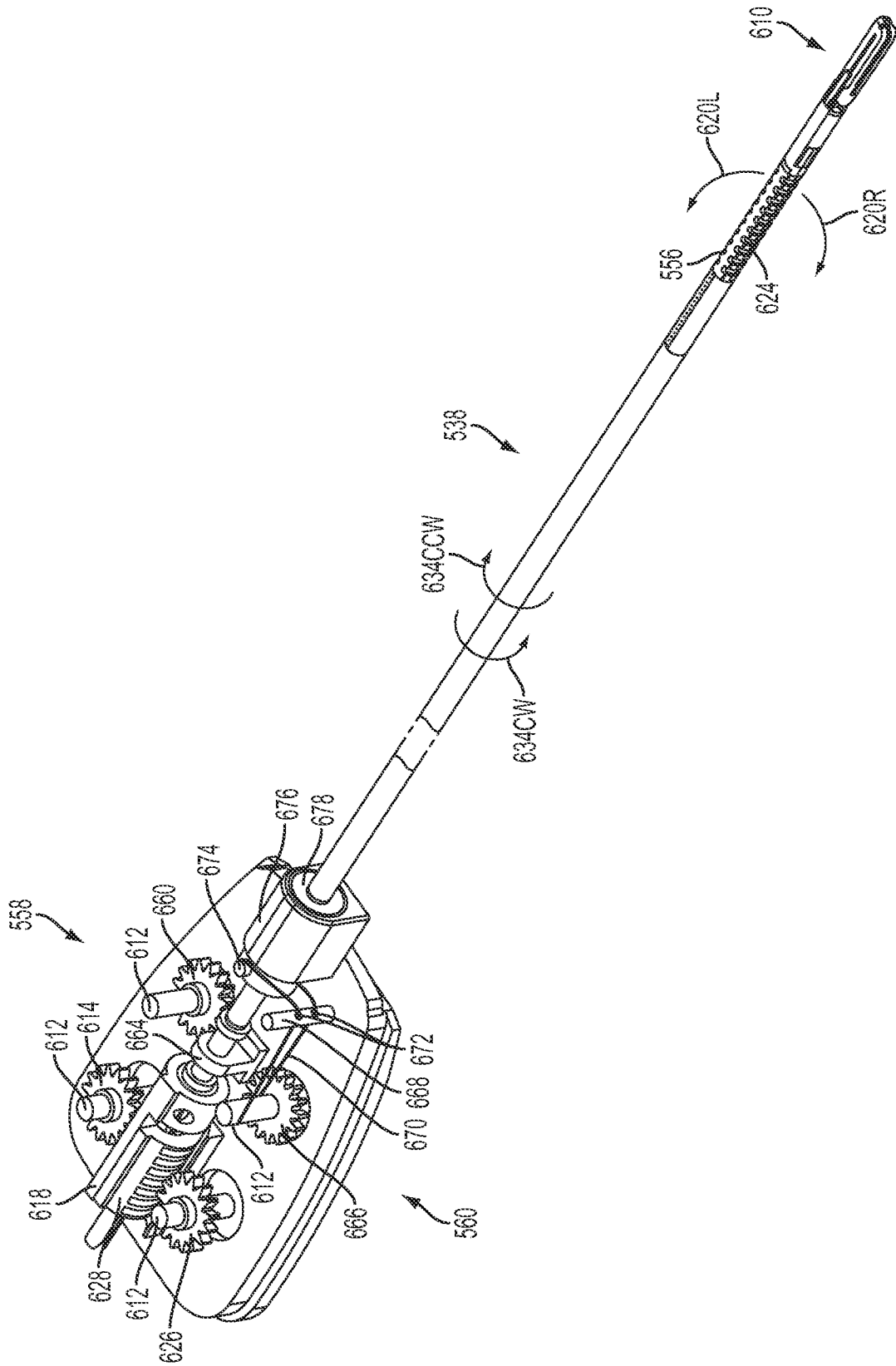

FIG. 39

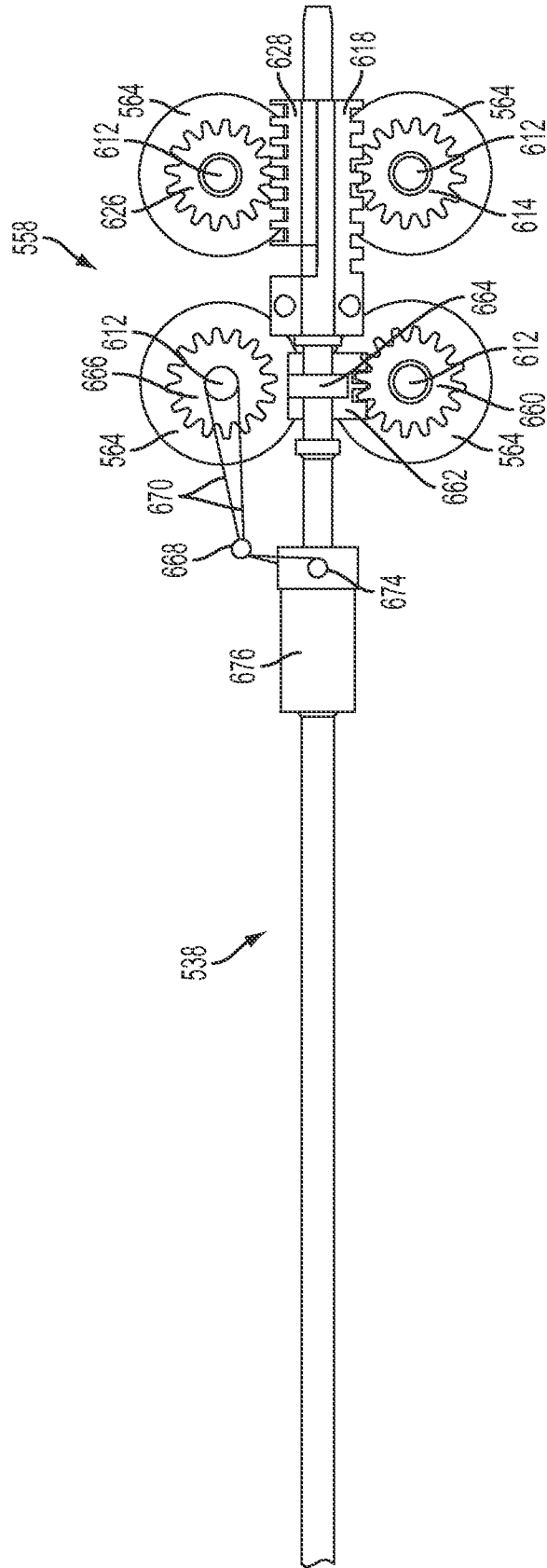

FIG. 40

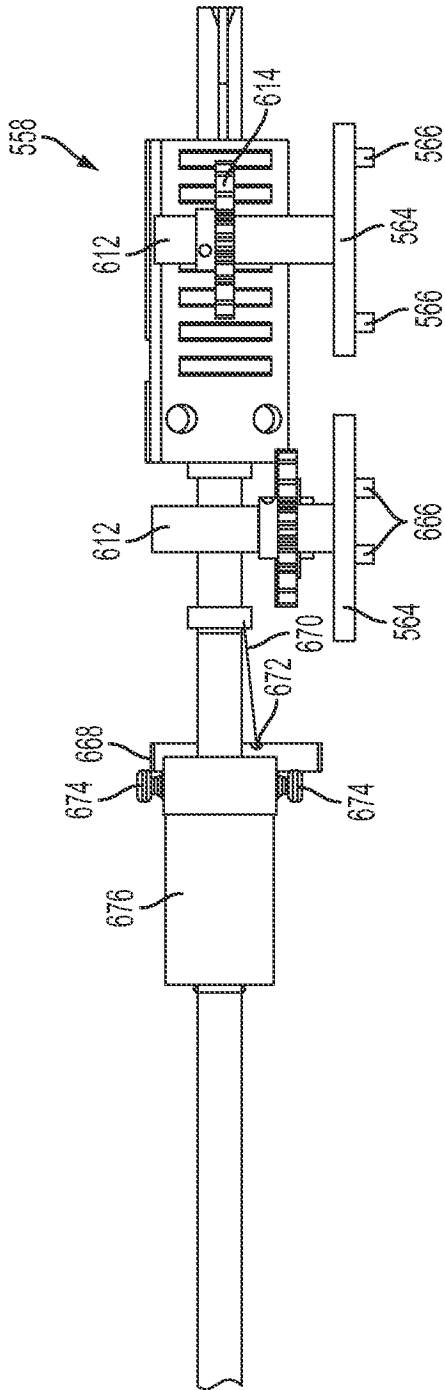

FIG. 41

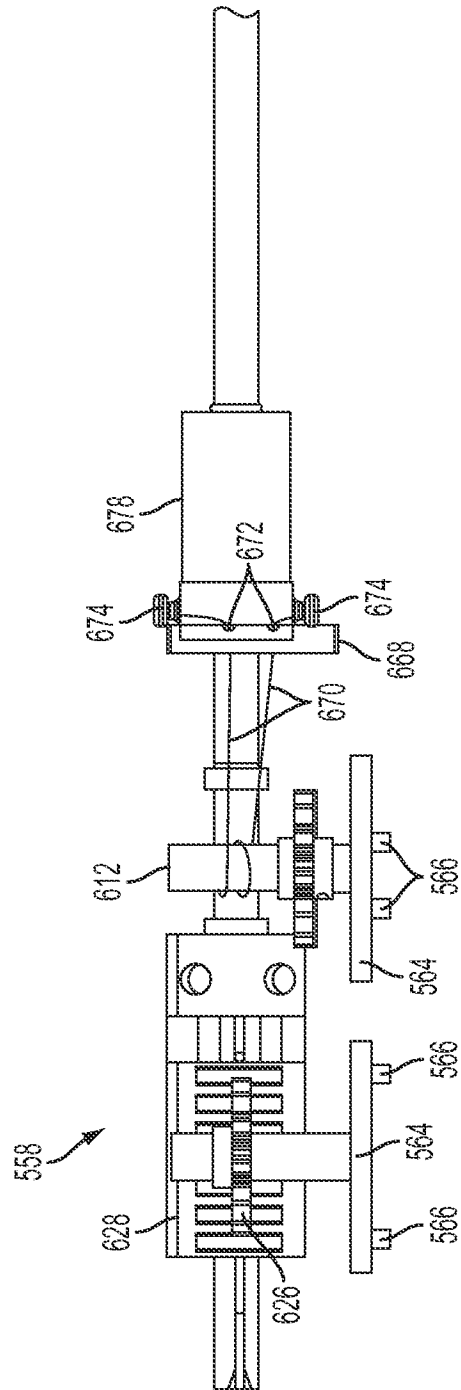

FIG. 42

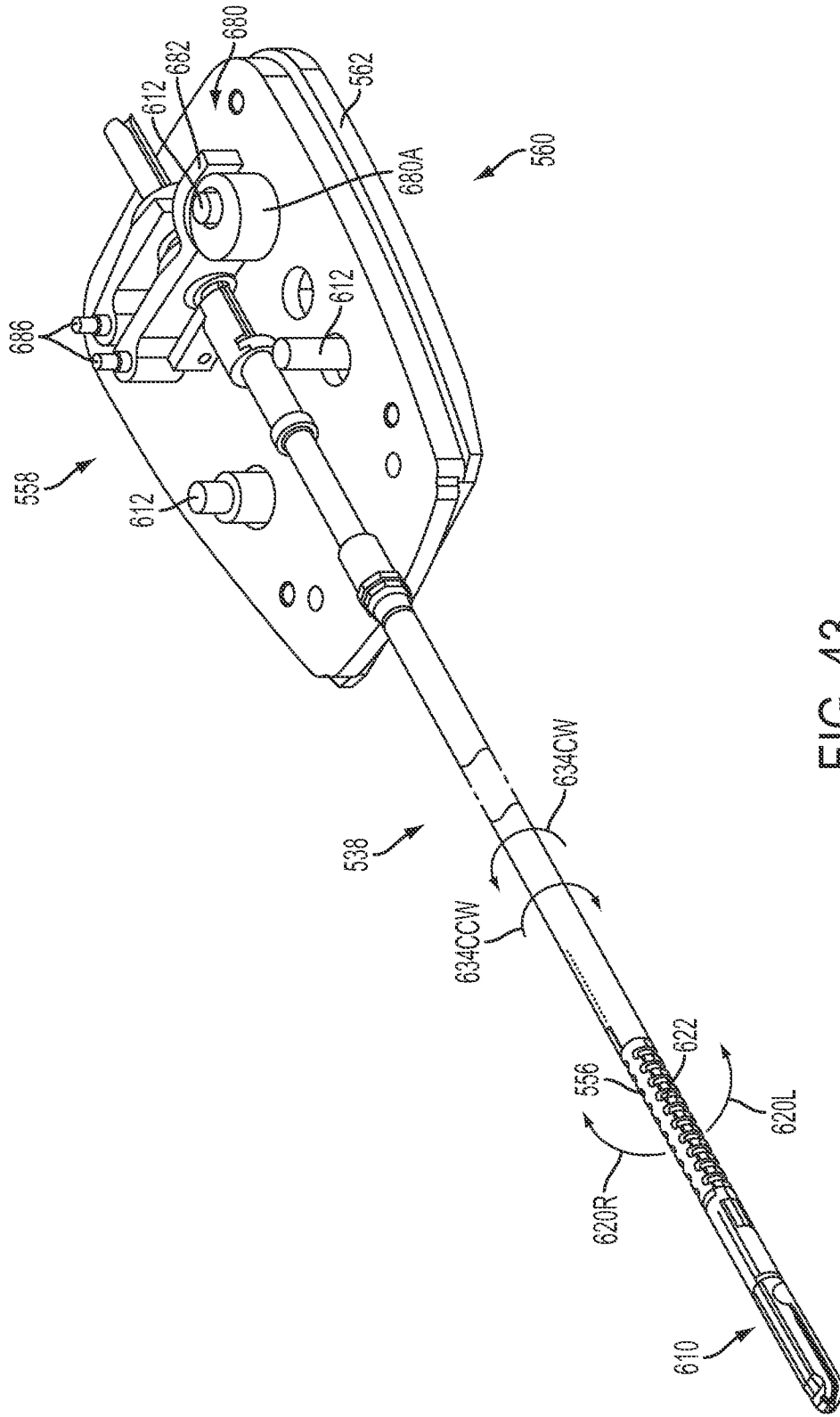

FIG. 43

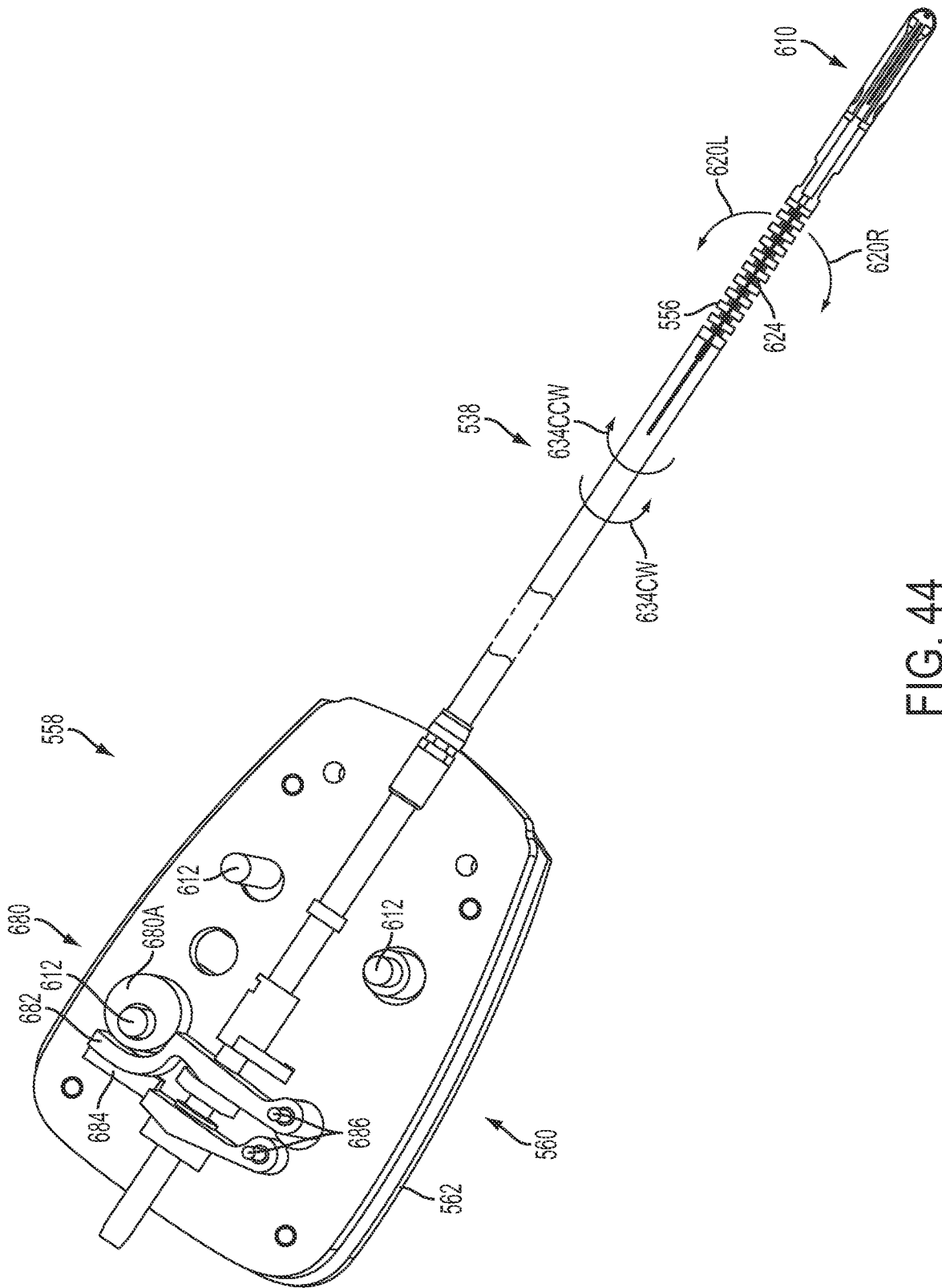

FIG. 44

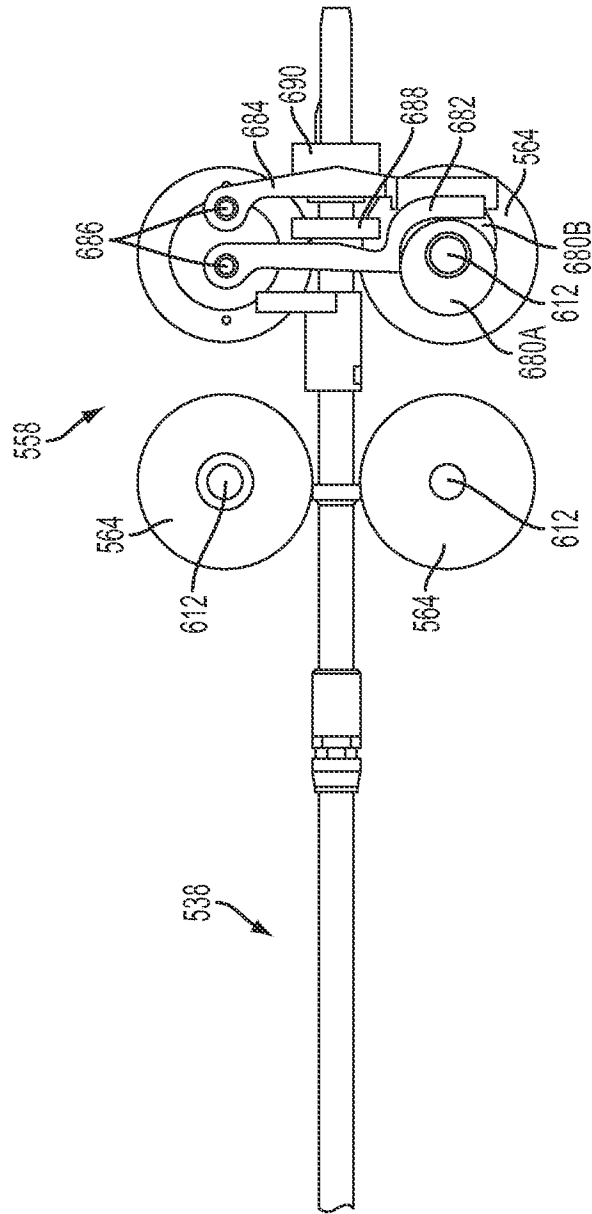

FIG. 45

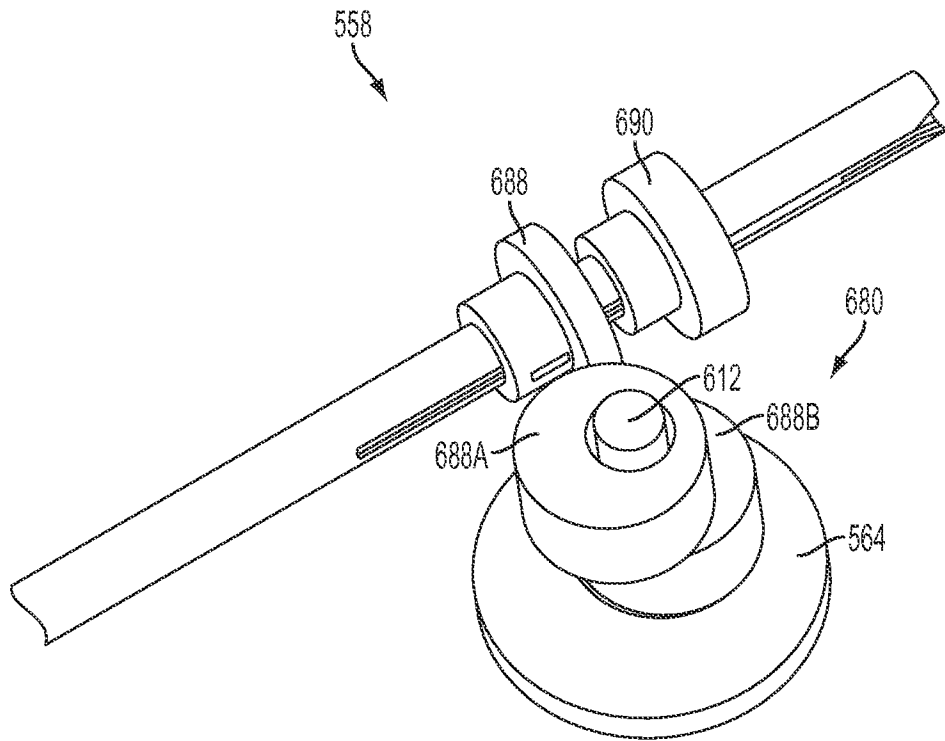

FIG. 46A

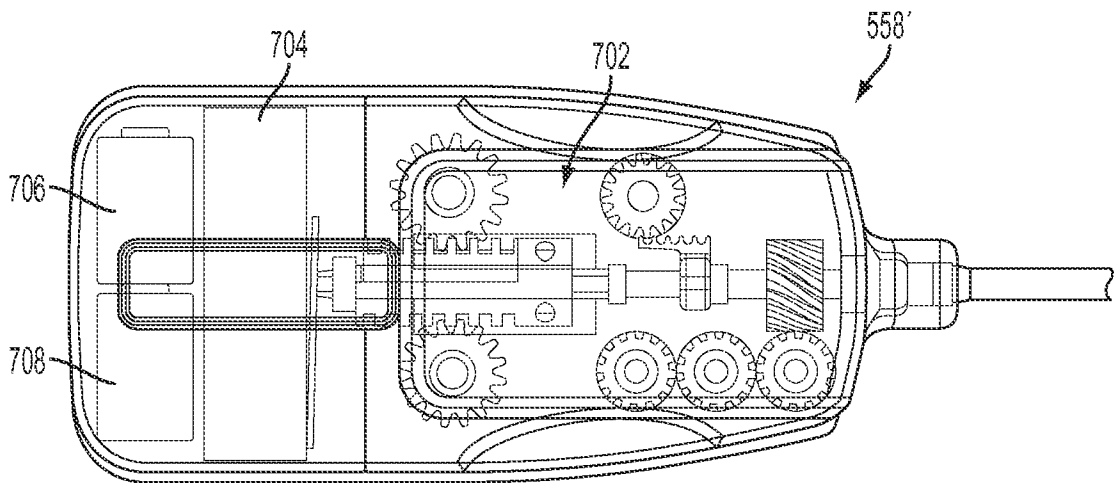

FIG. 46B

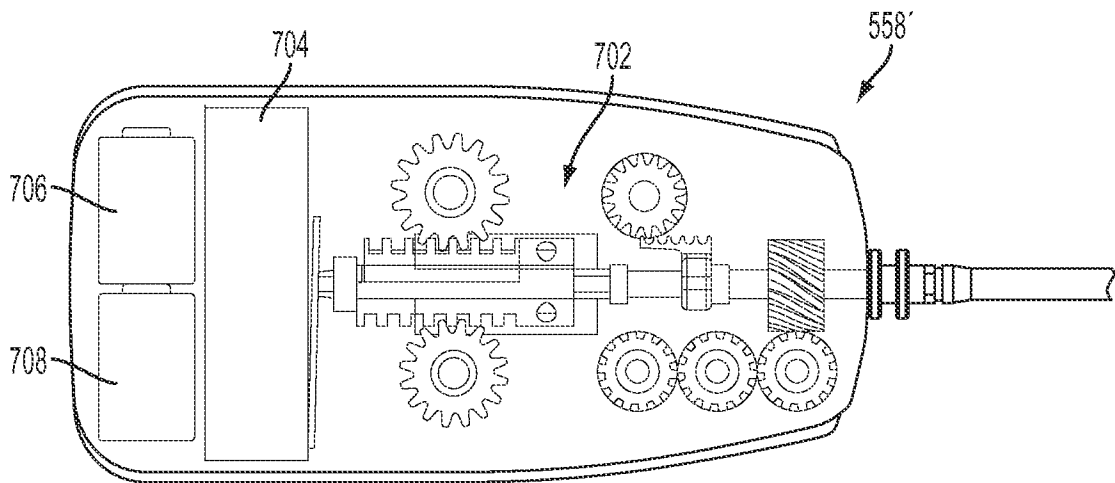

FIG. 46C

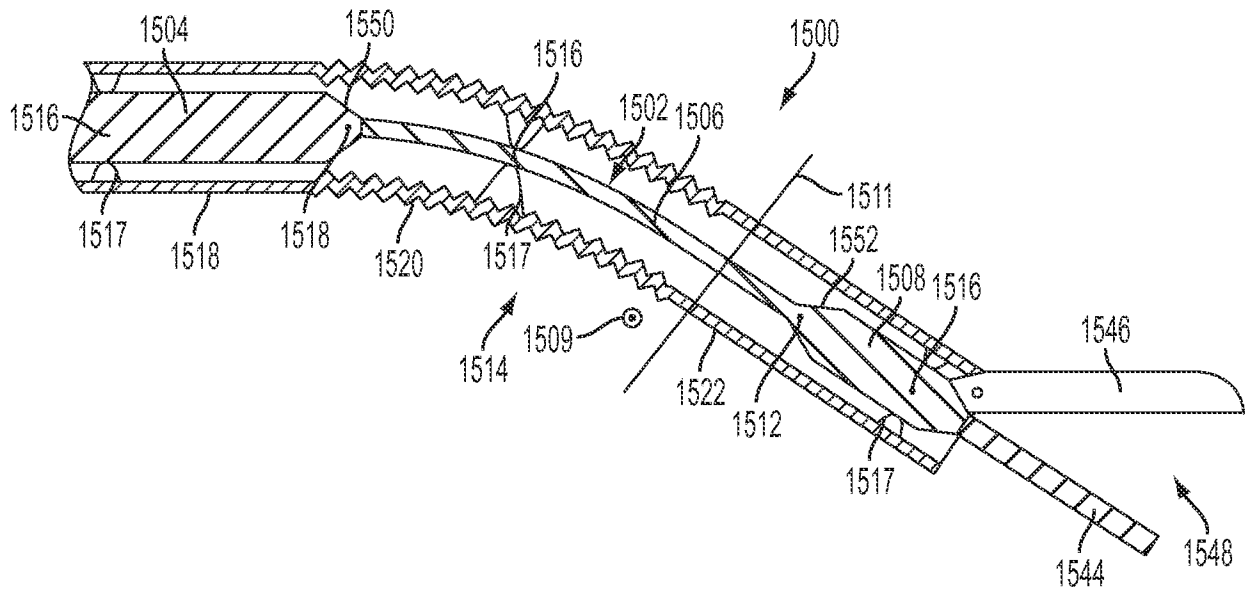

FIG. 47

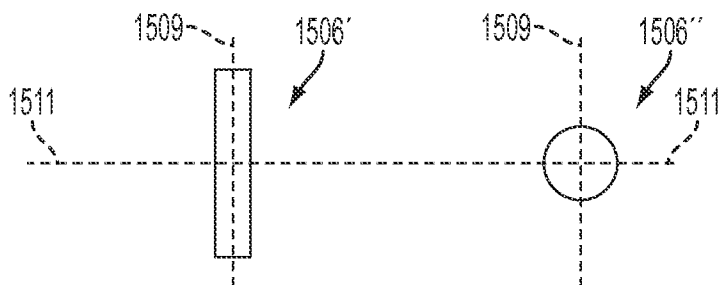

FIG. 47A

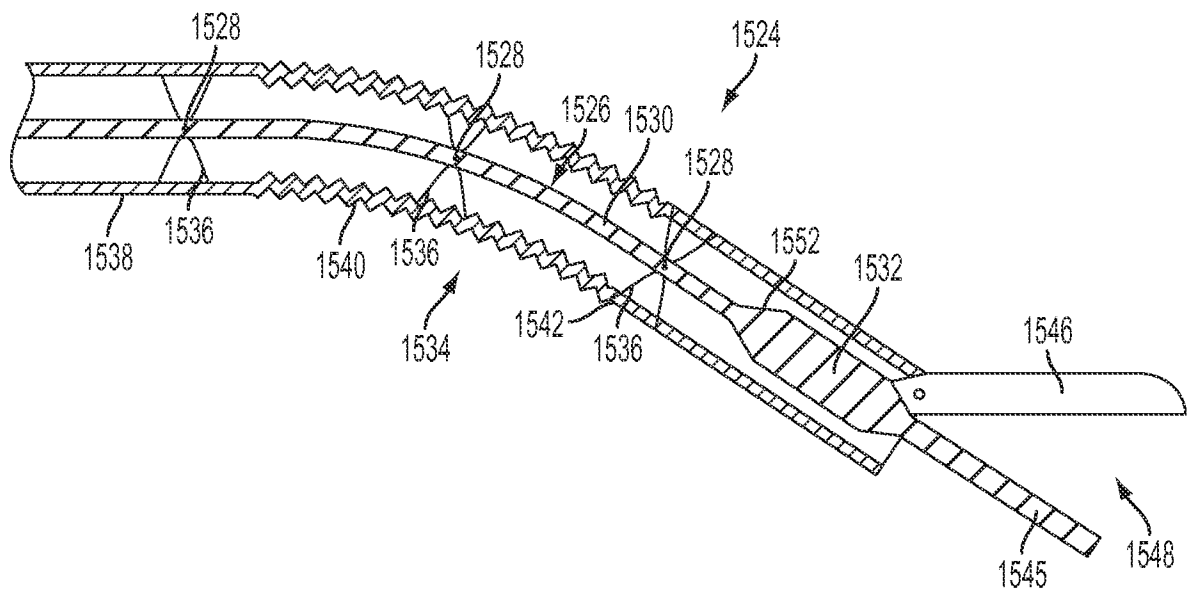

FIG. 48

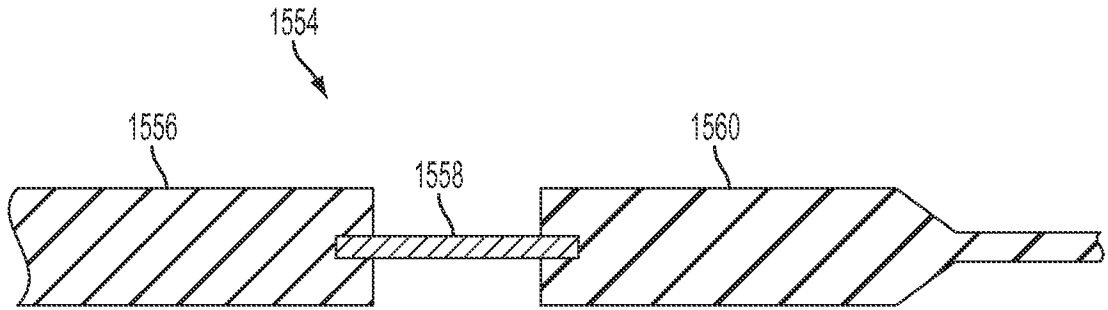

FIG. 49

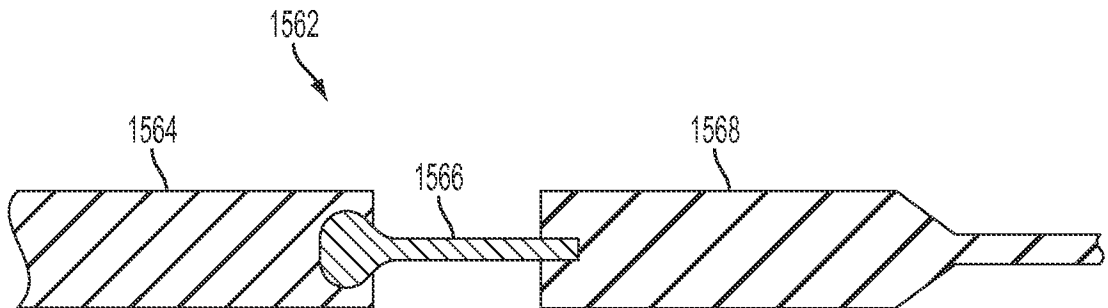

FIG. 50

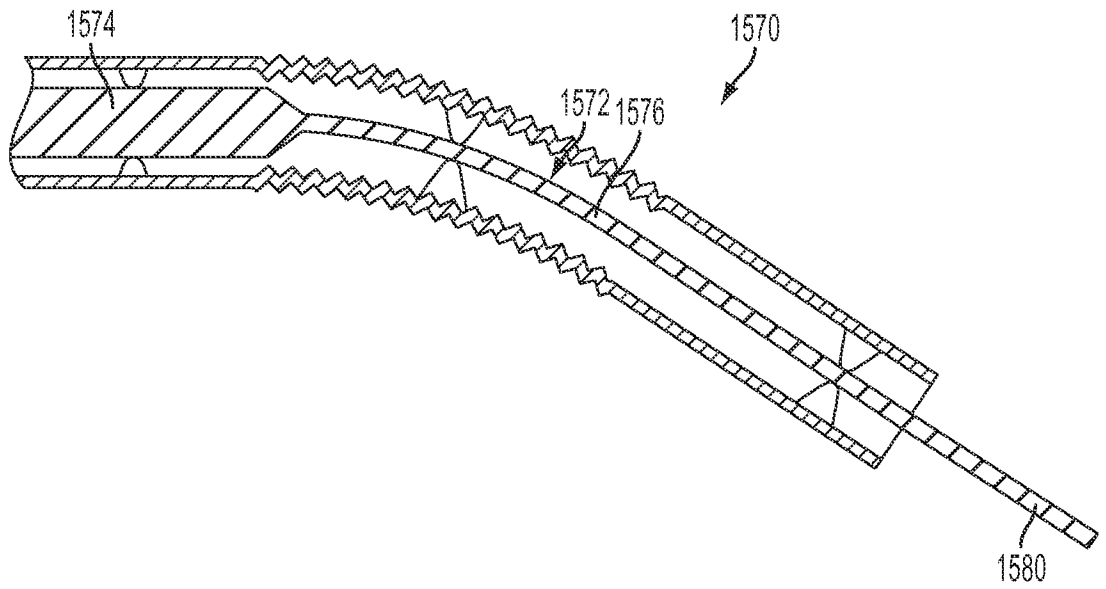

FIG. 51

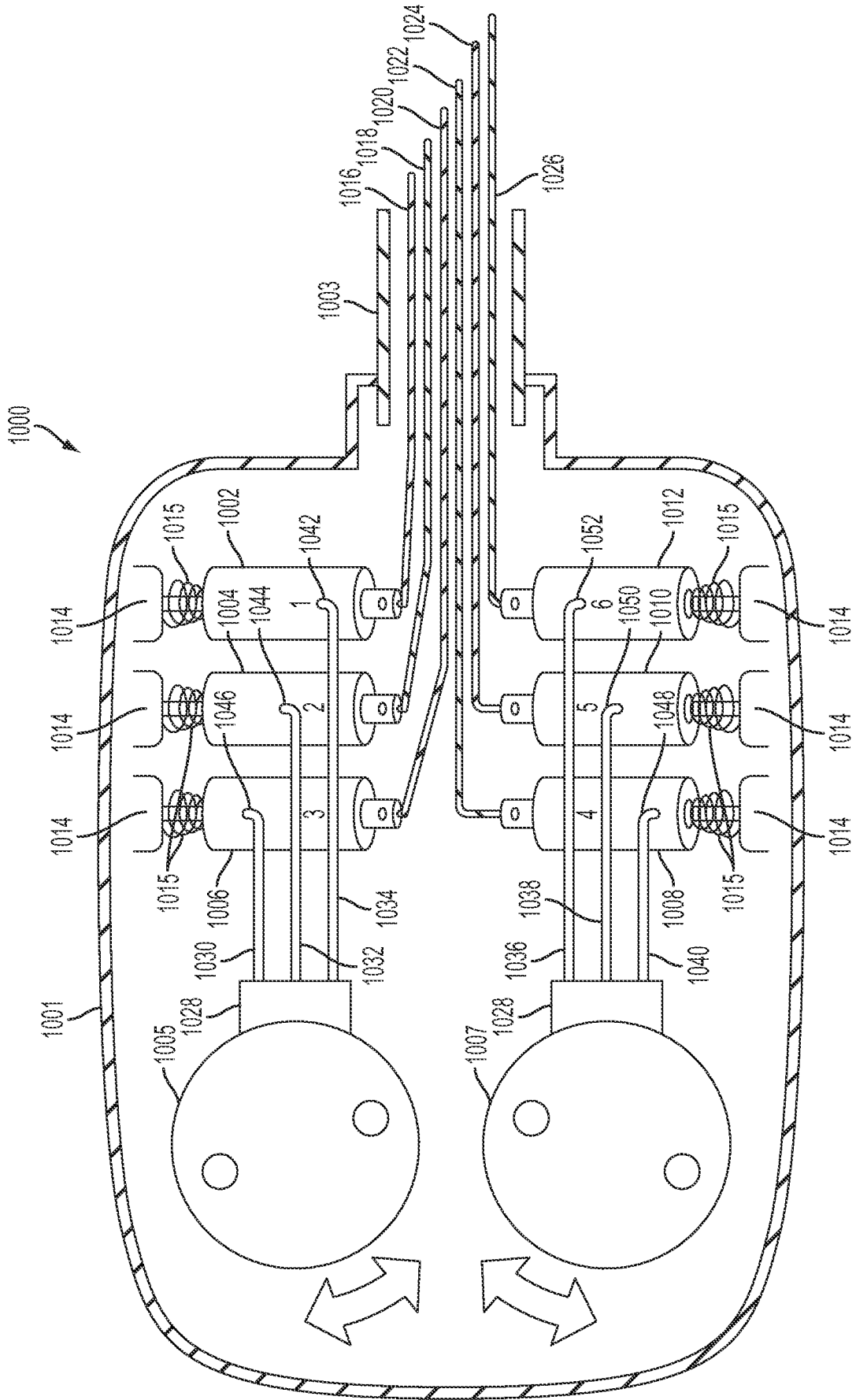

FIG. 52

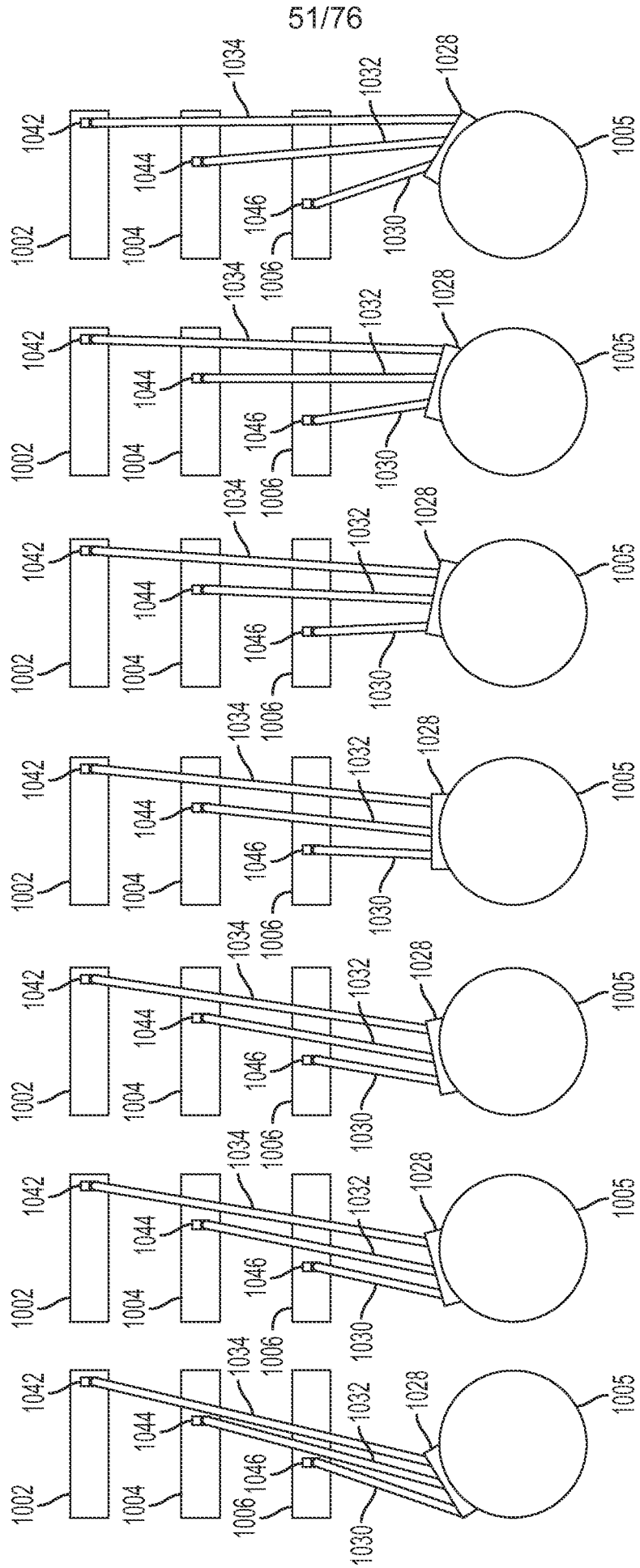

FIG. 53A FIG. 53B FIG. 53C FIG. 53D FIG. 53E FIG. 53F FIG. 53G

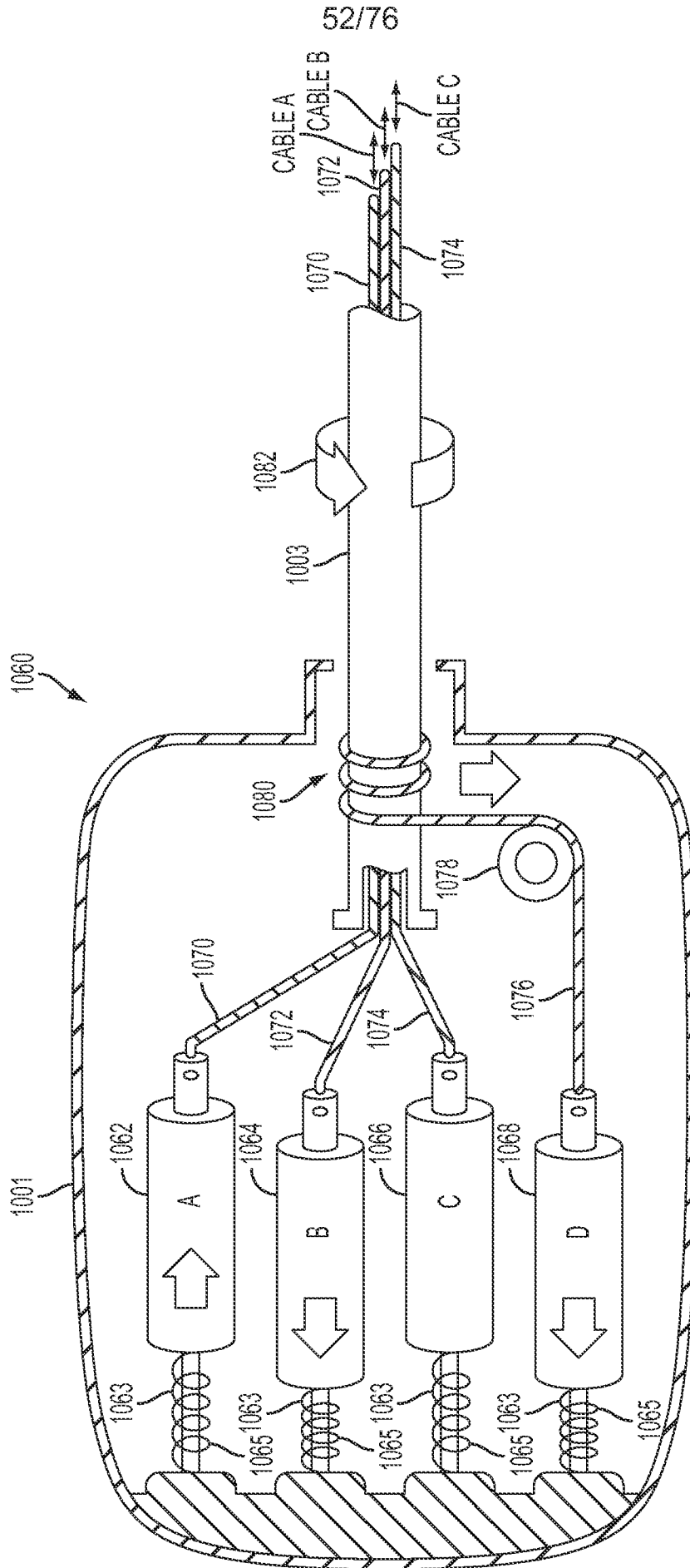

FIG. 54

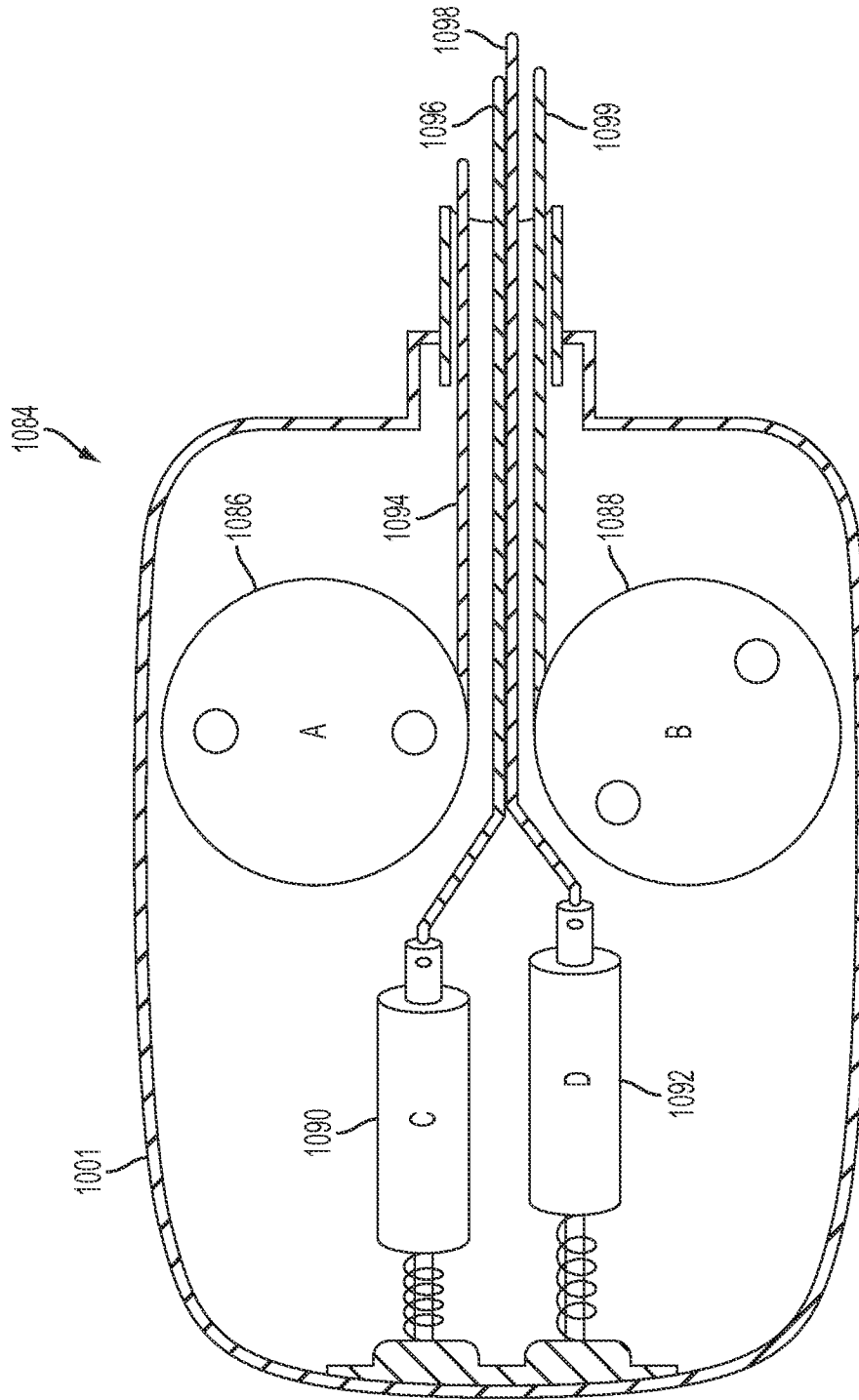

FIG. 55

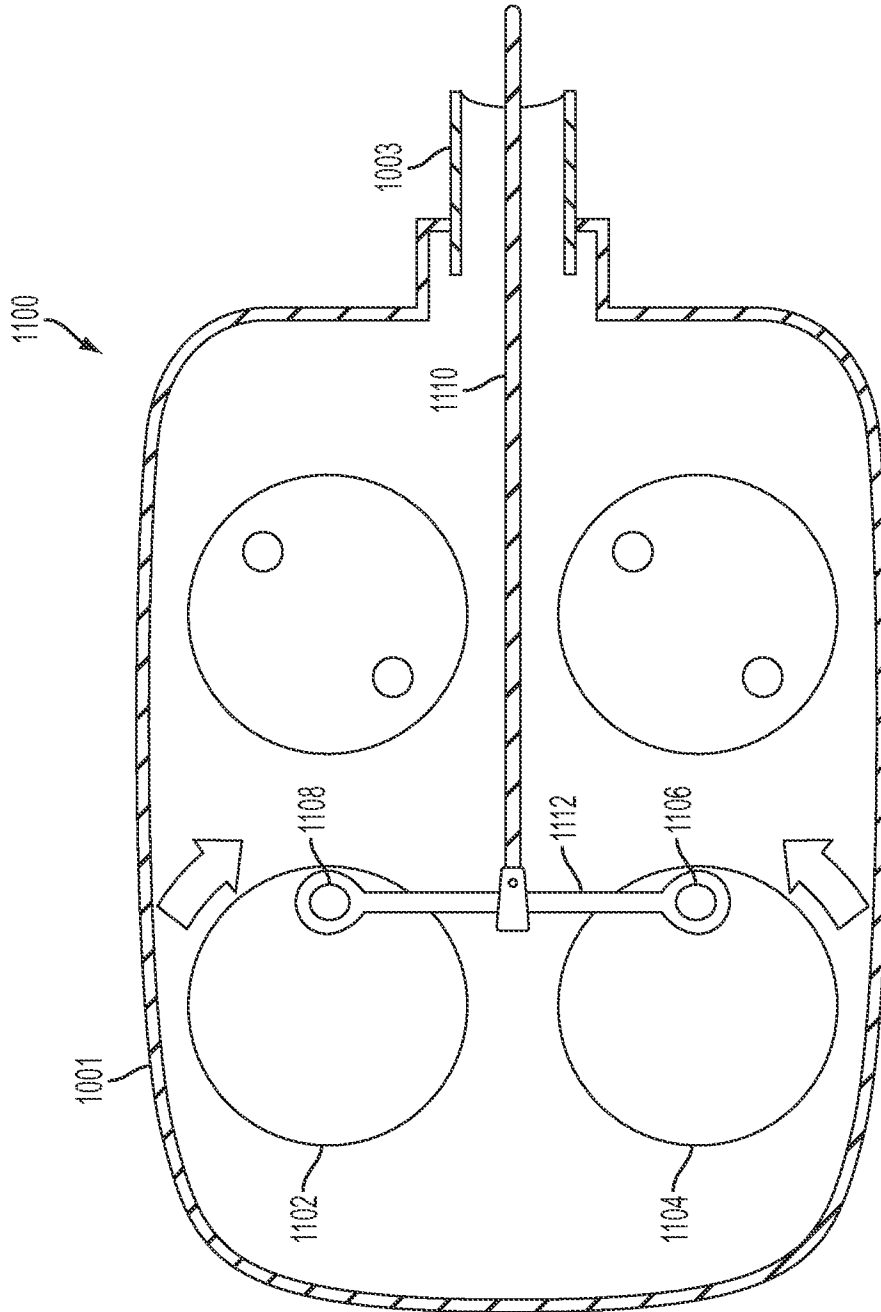

FIG. 56

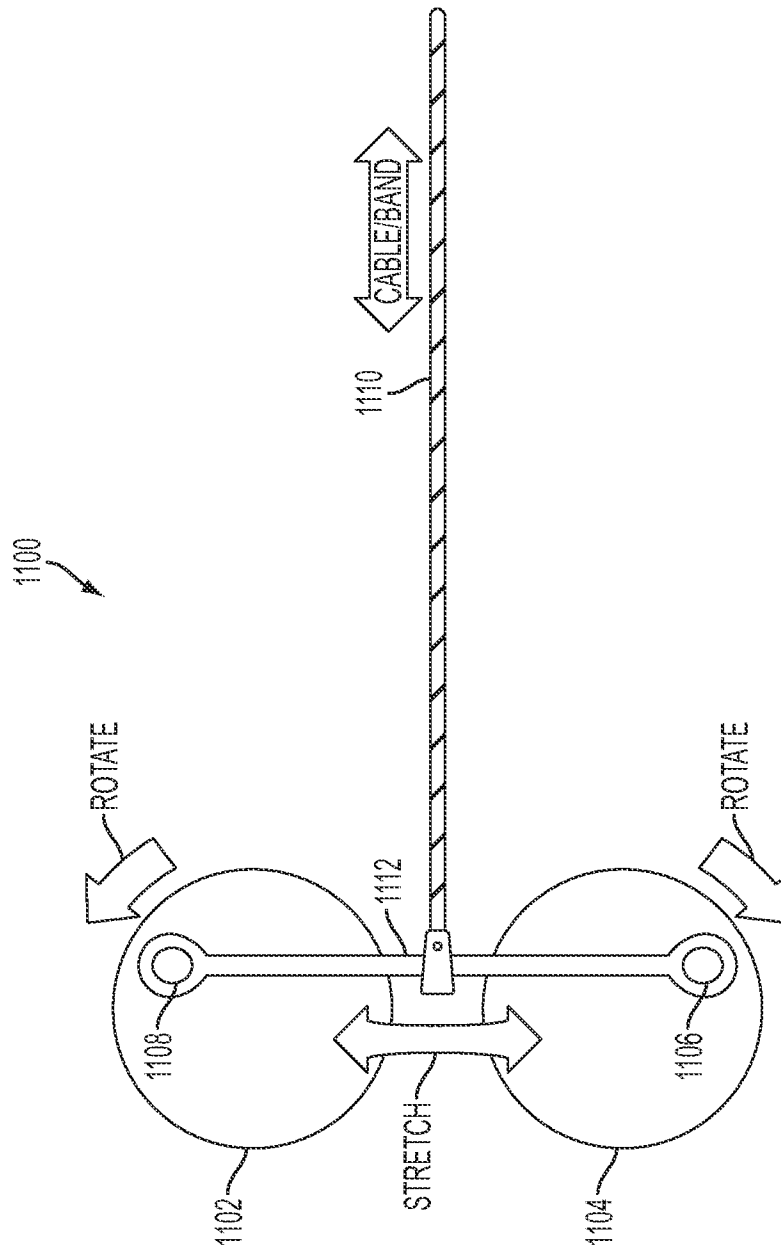

FIG. 57

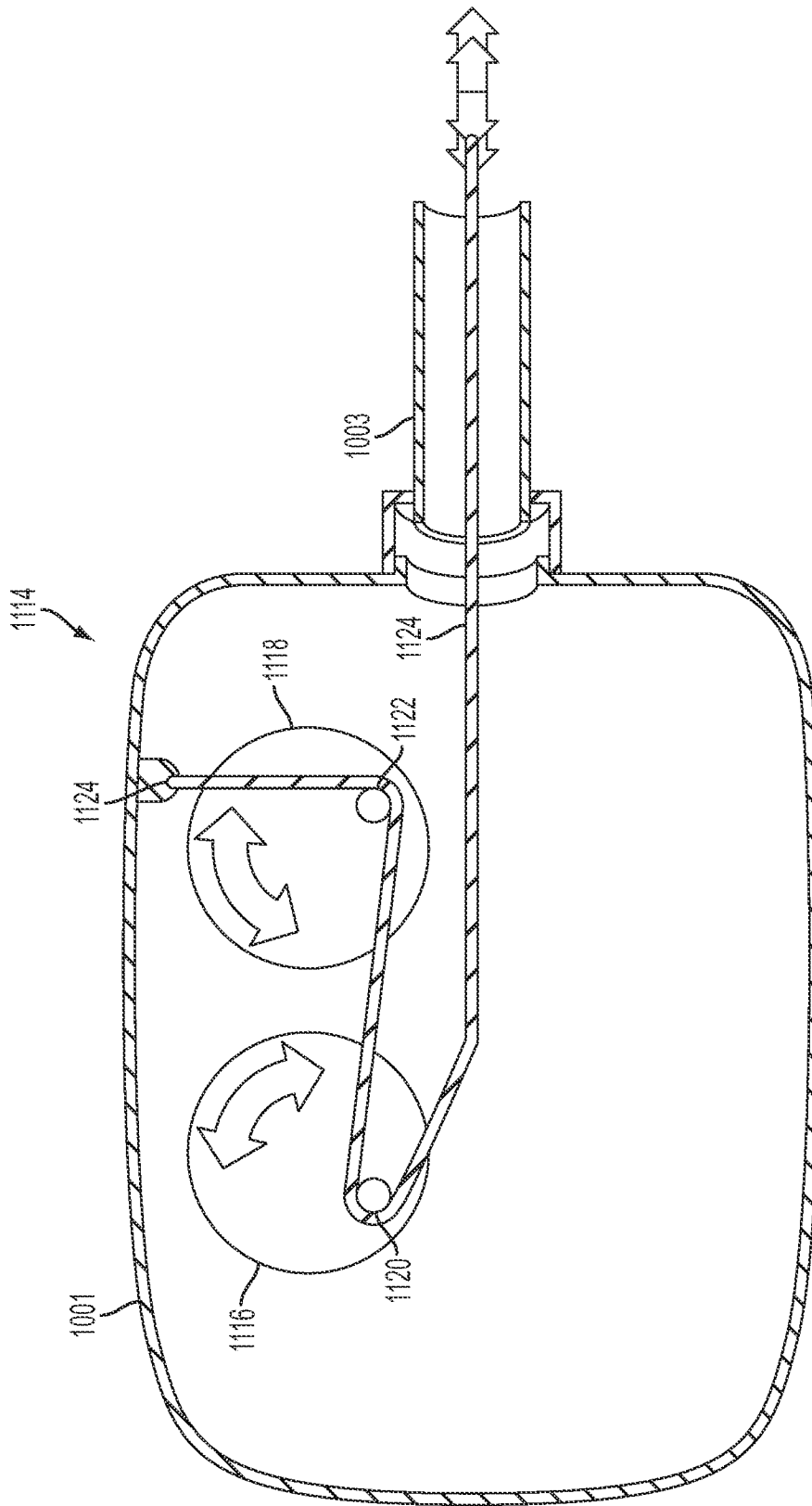

FIG. 58

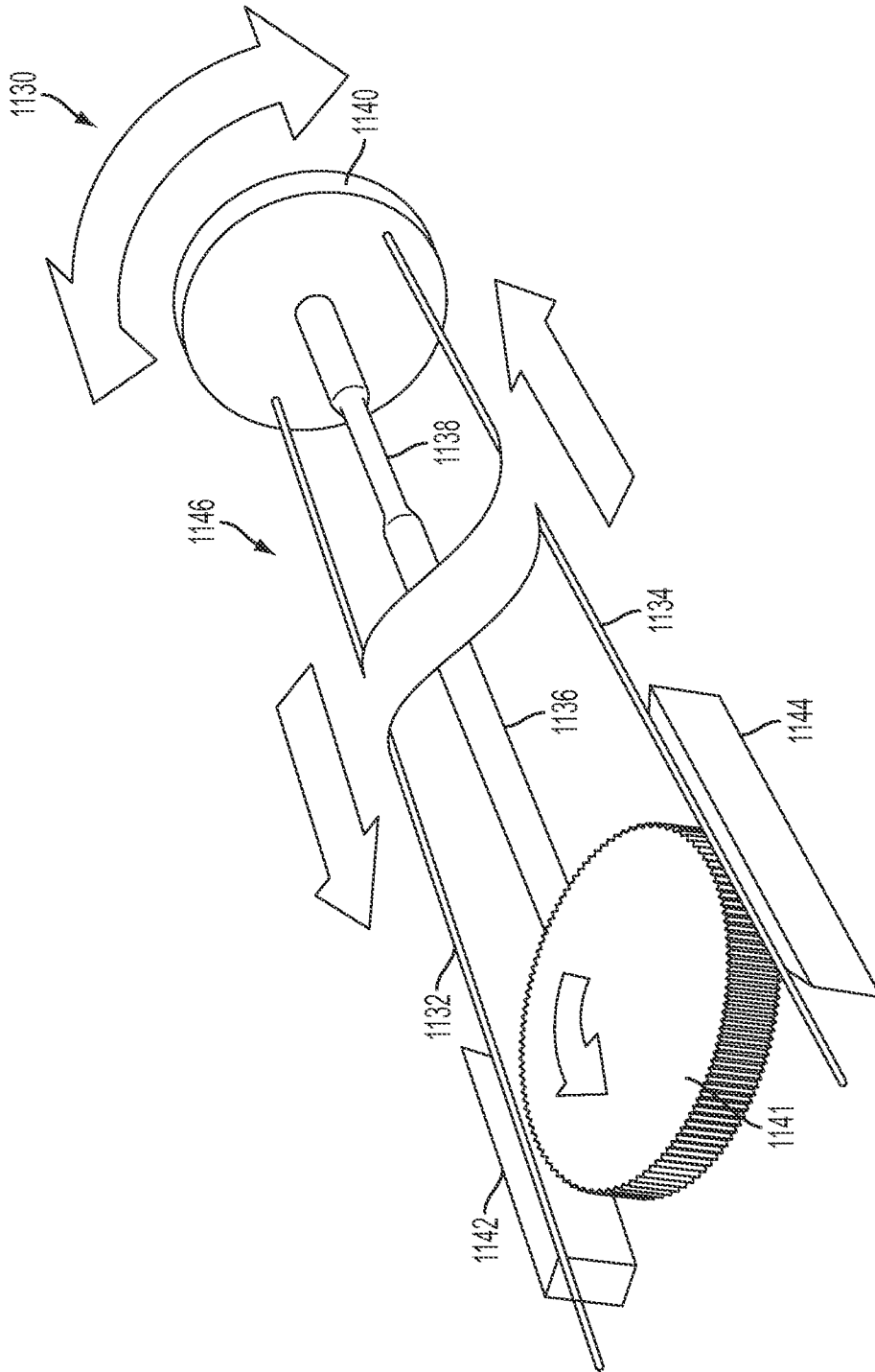

FIG. 59

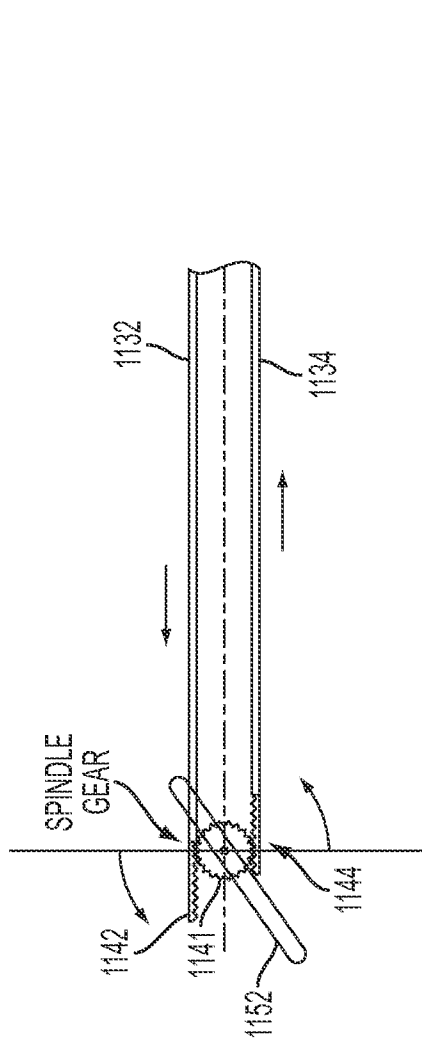

FIG. 60

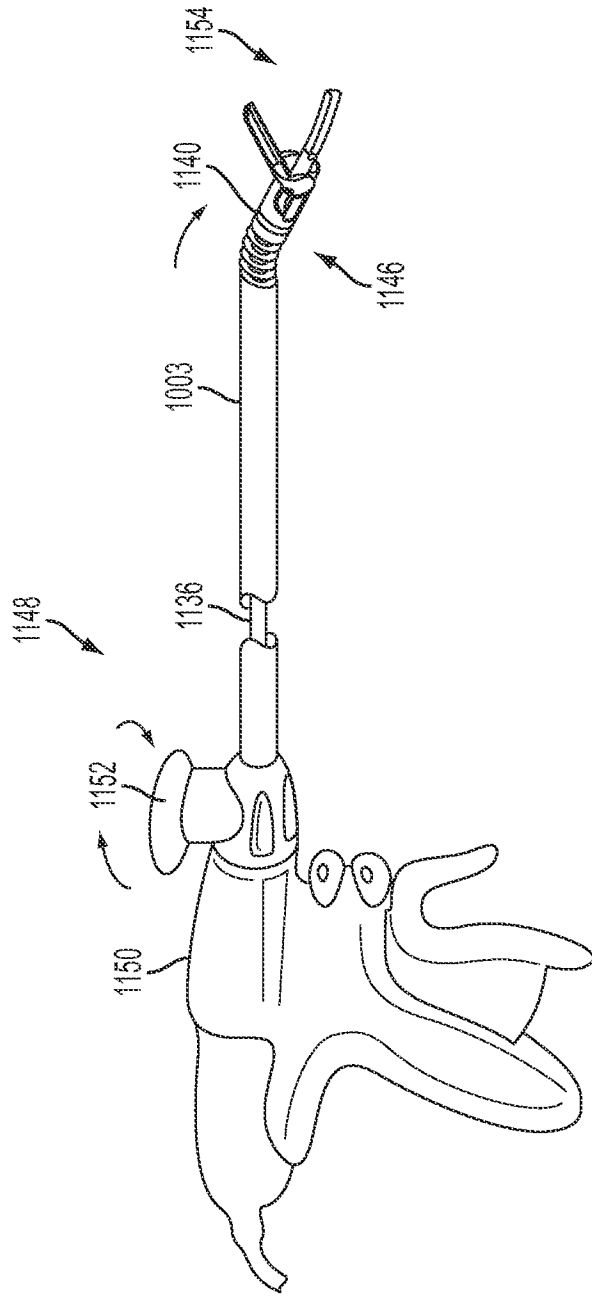

FIG. 61

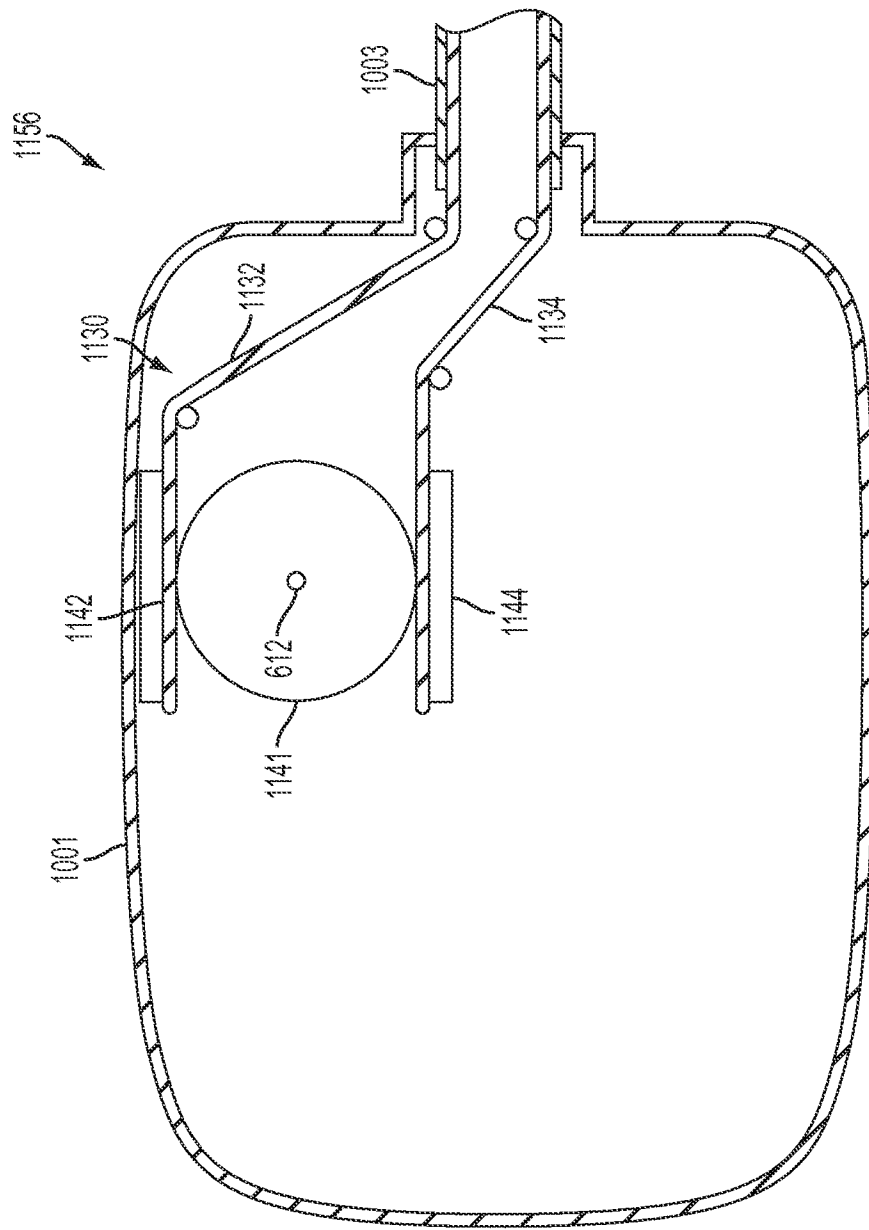

FIG. 62

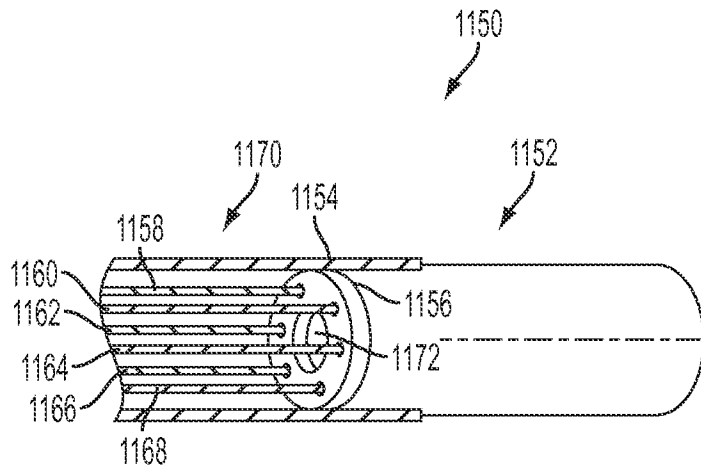

FIG. 63A

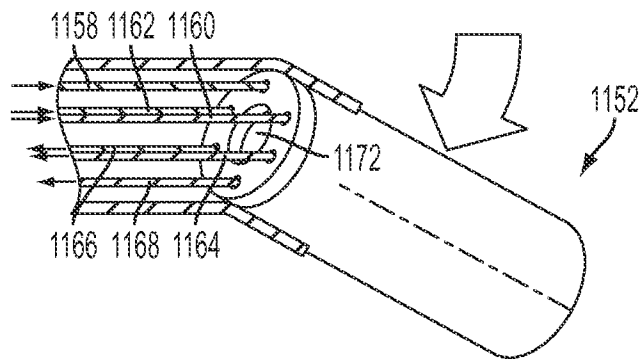

FIG. 63B

61/76

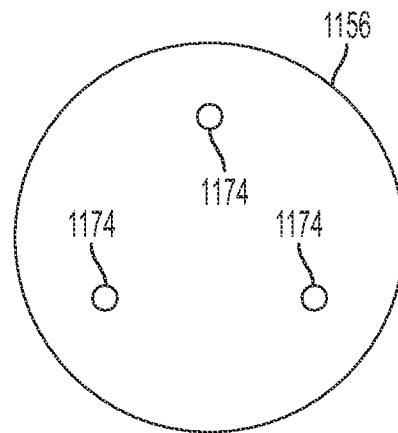

FIG. 64

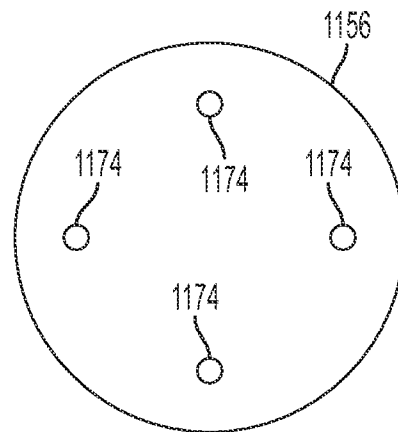

FIG. 65

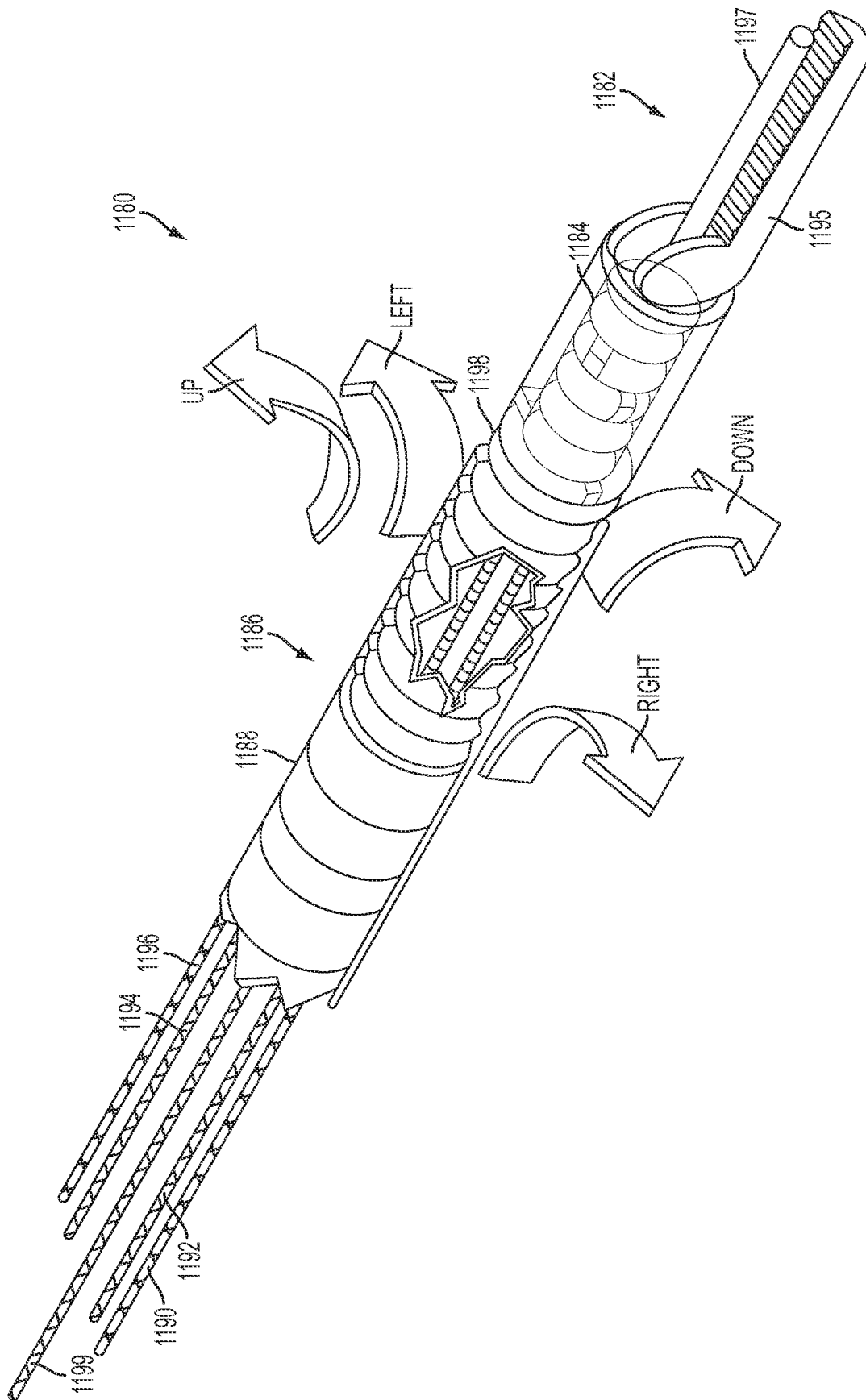

FIG. 66

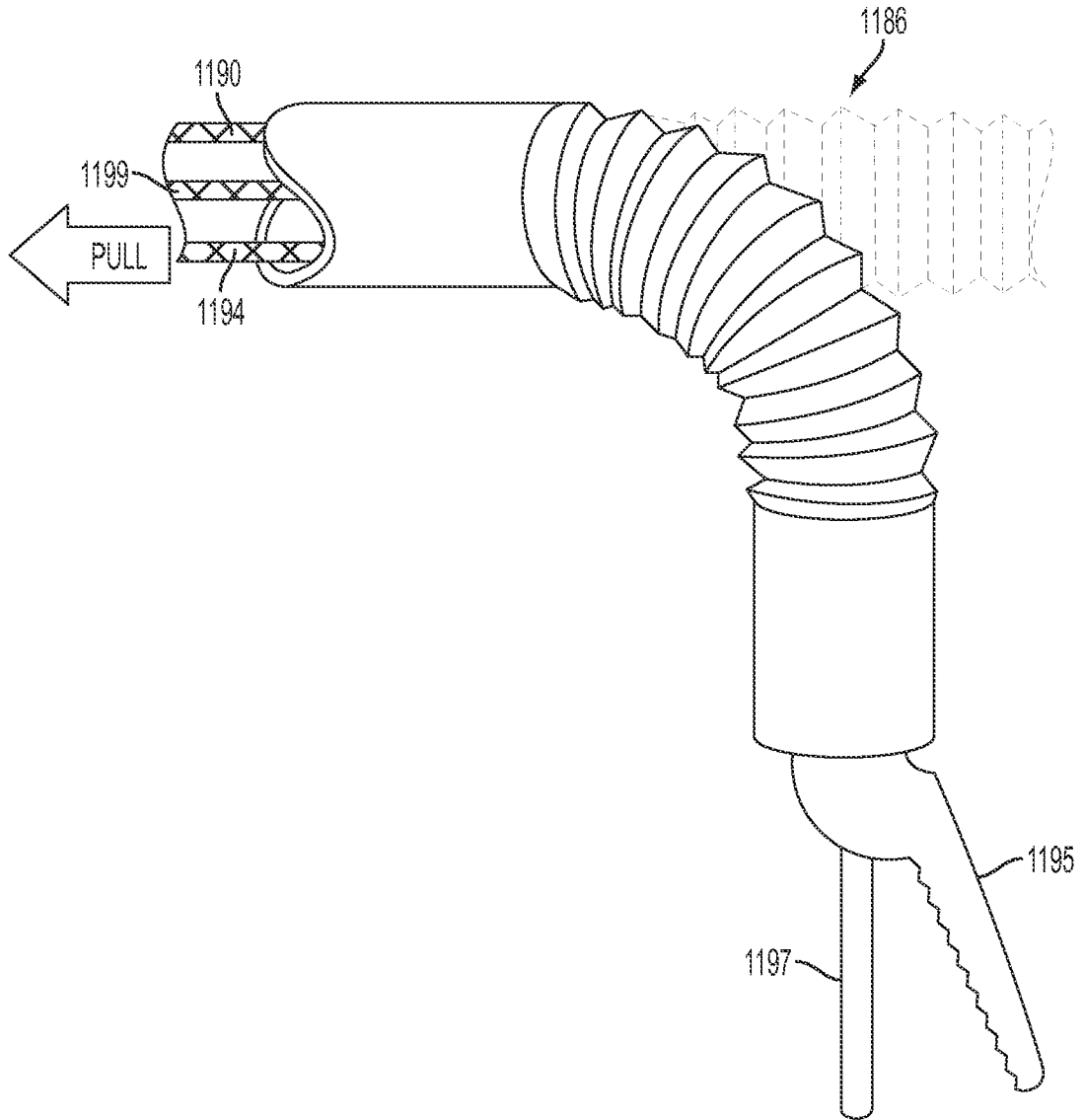

FIG. 67

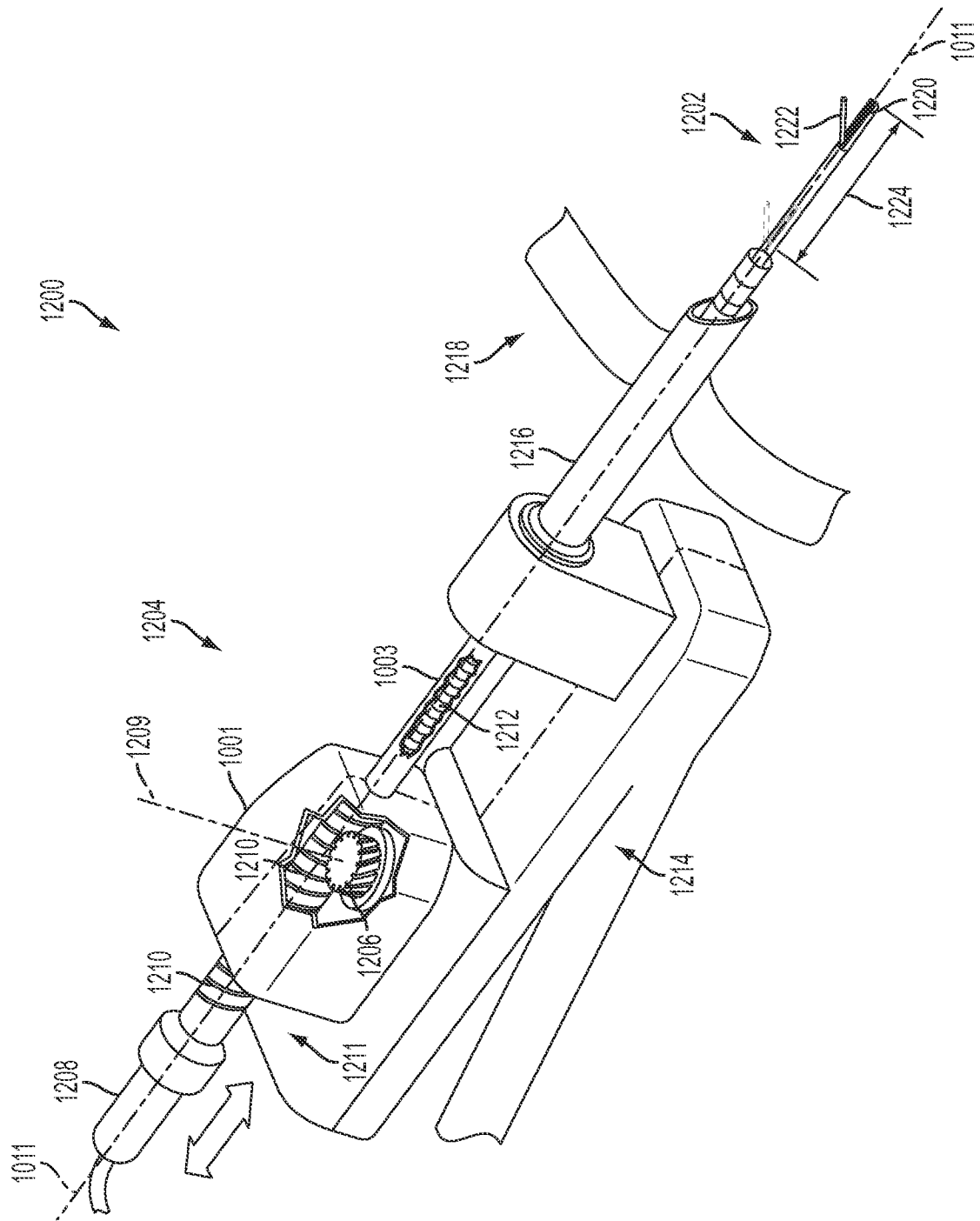

FIG. 68

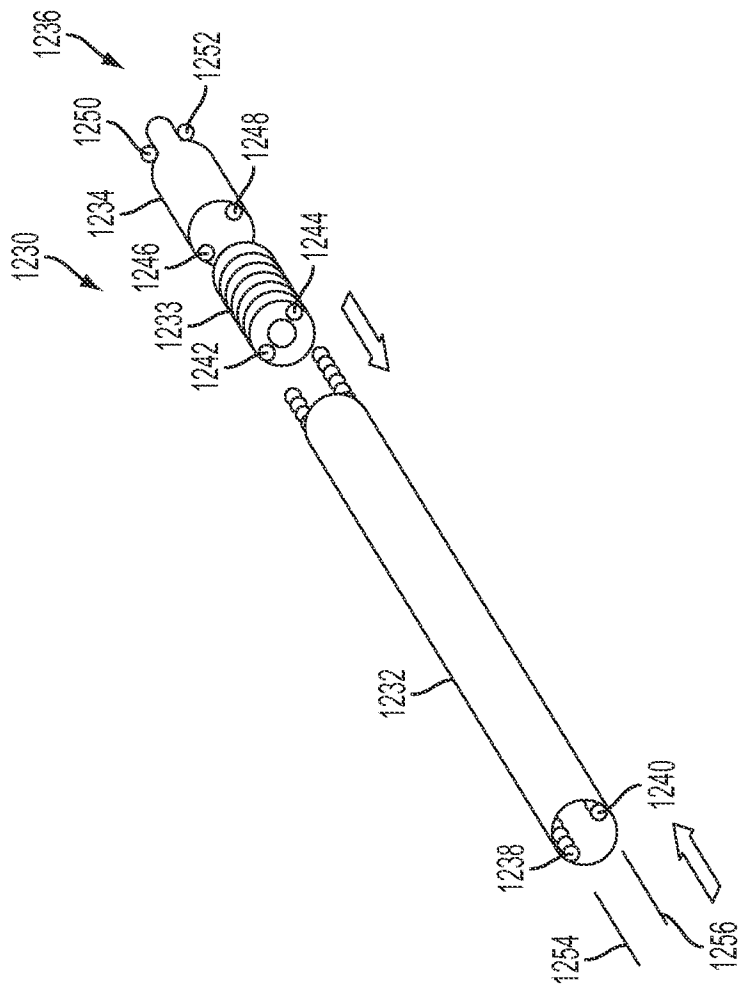

FIG. 69A

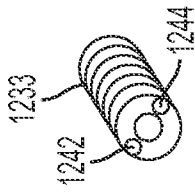

FIG. 69B

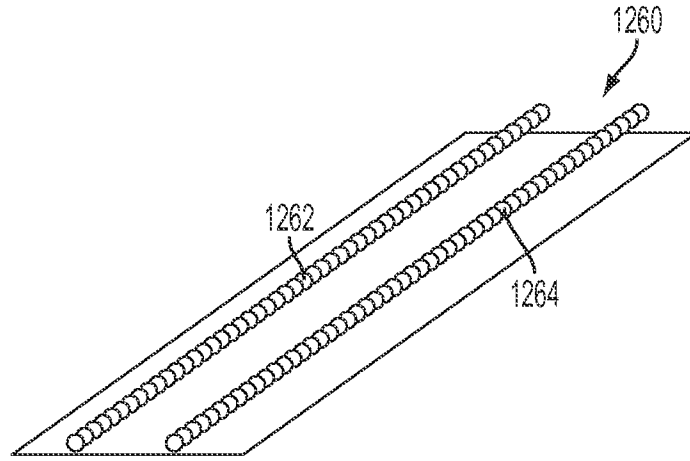

FIG. 70

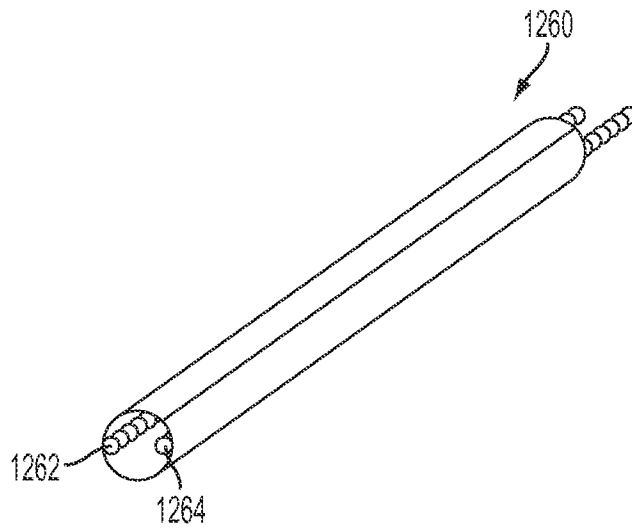

FIG. 71

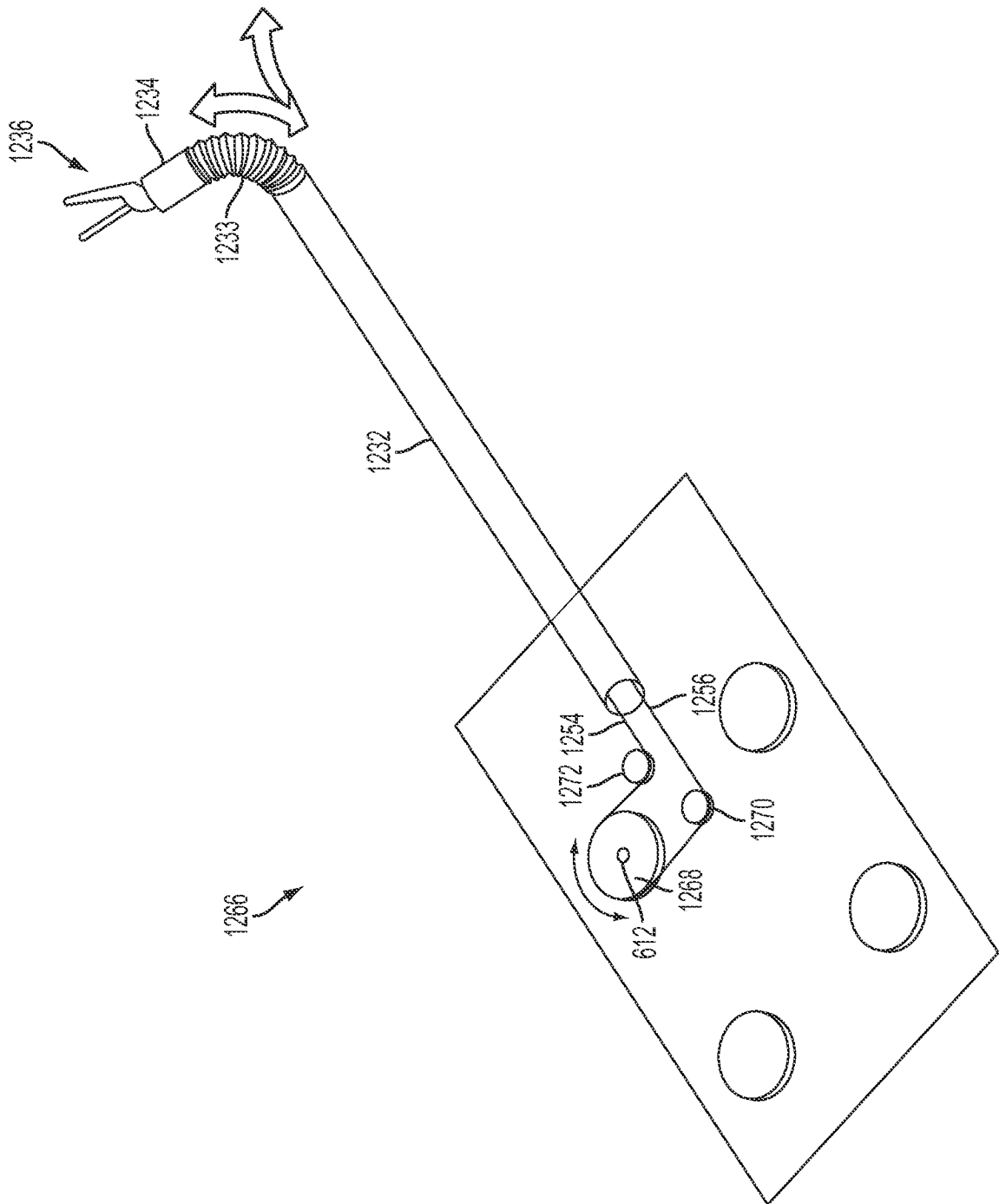

FIG. 72

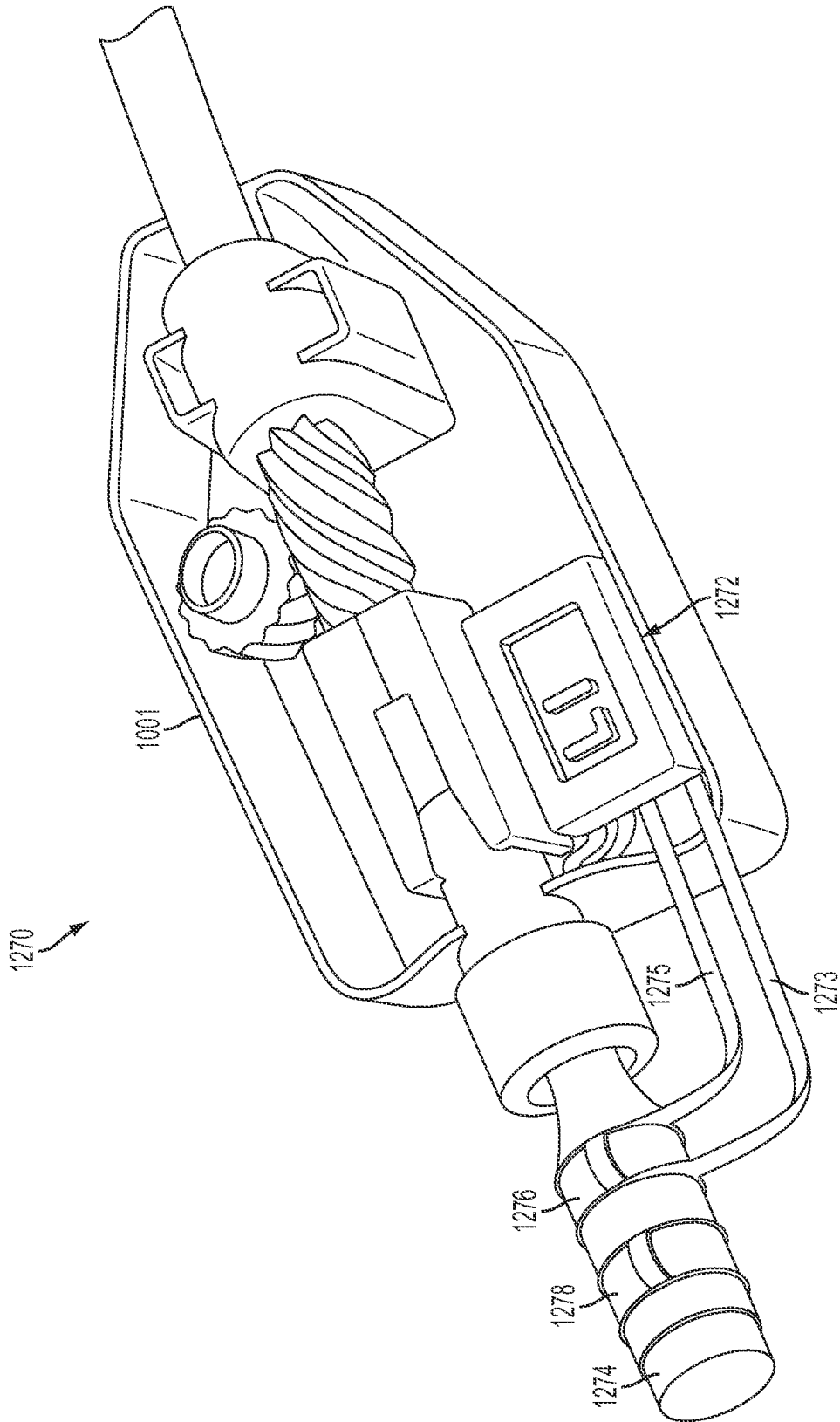

FIG. 73

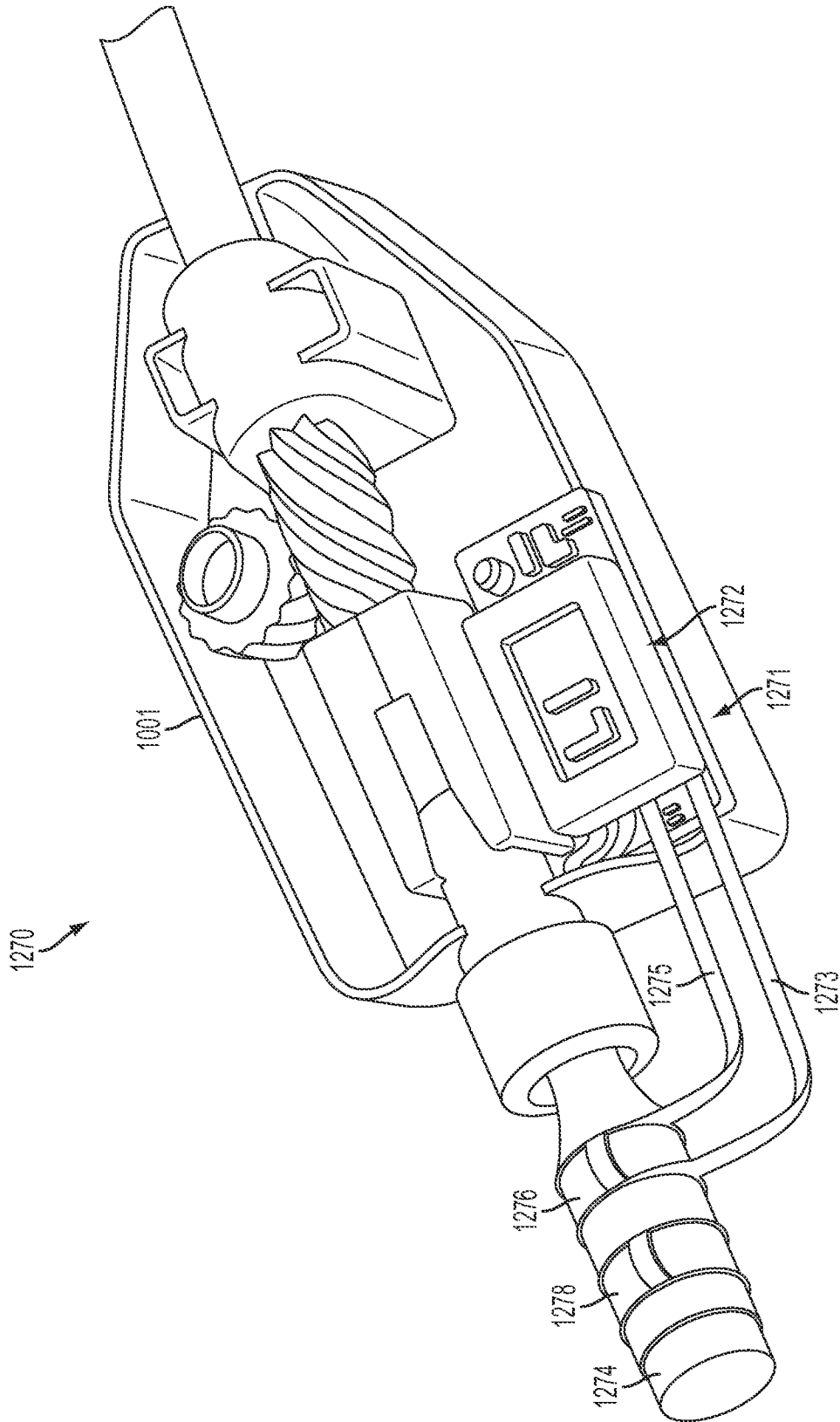

FIG. 74

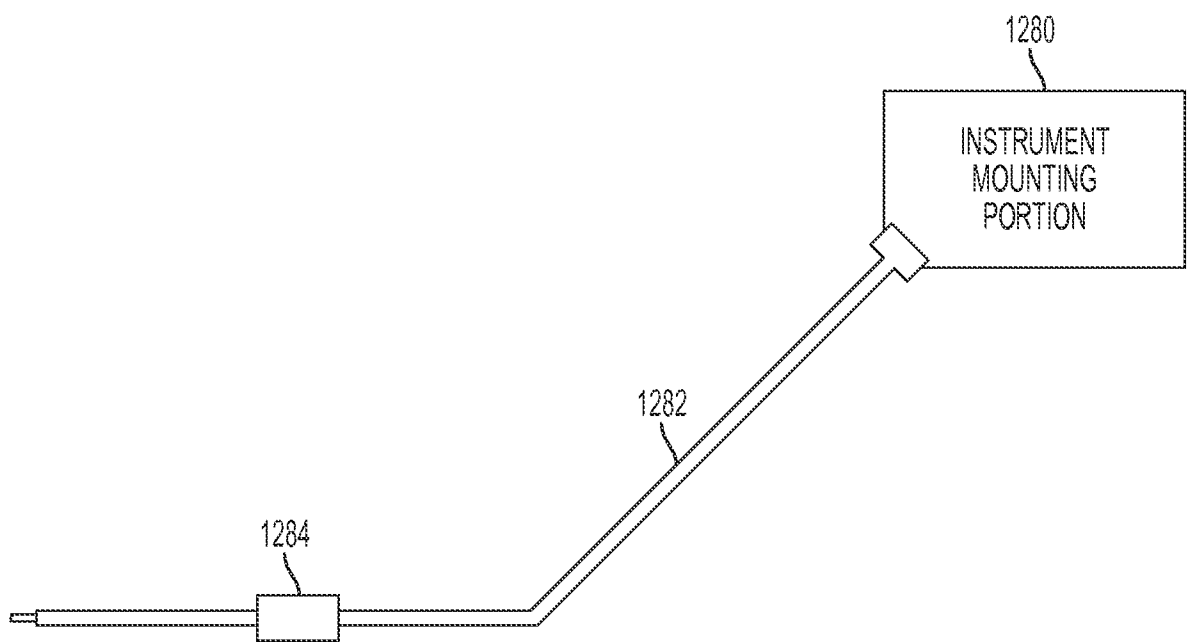

FIG. 75

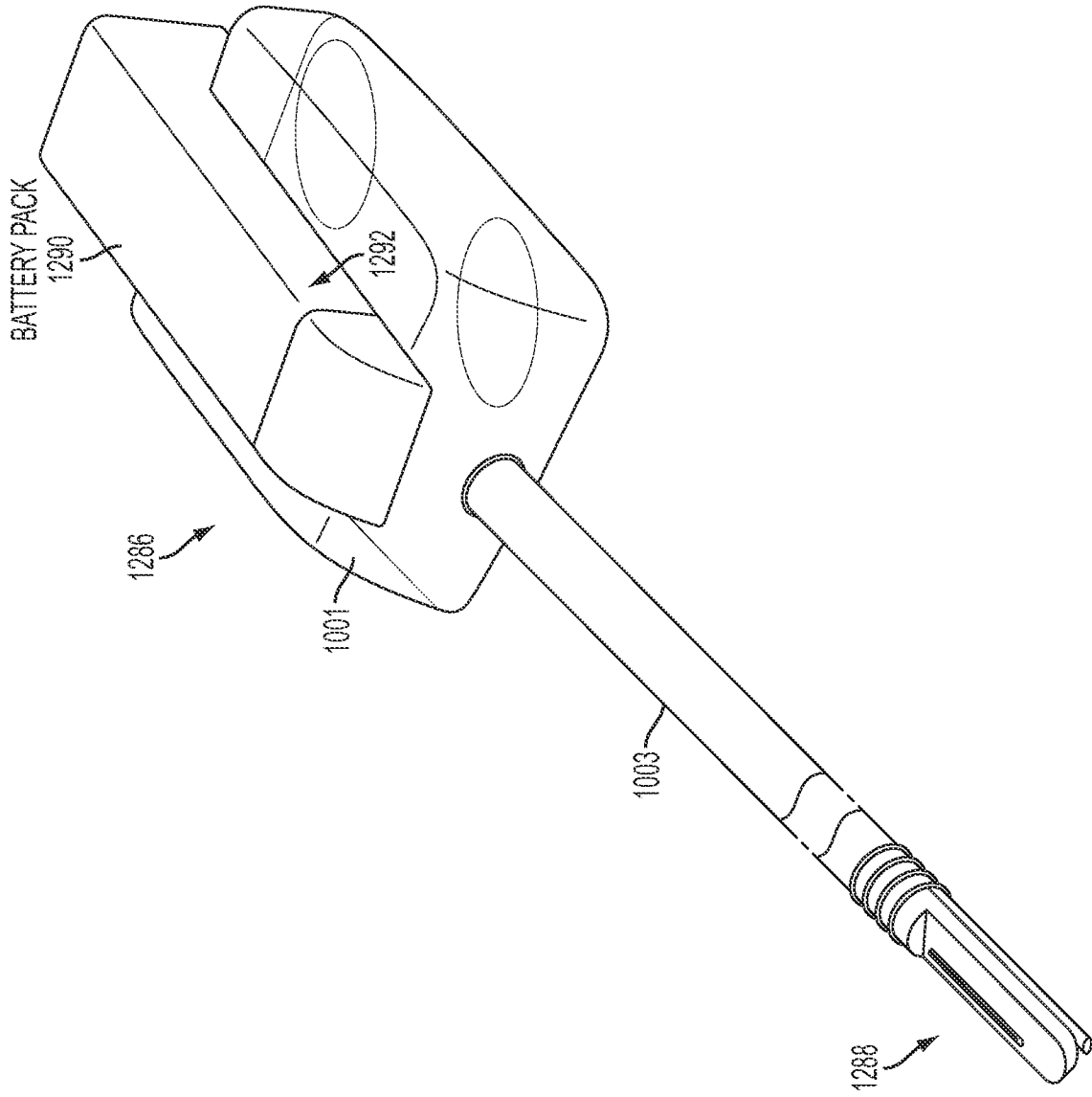

FIG. 76

72/76

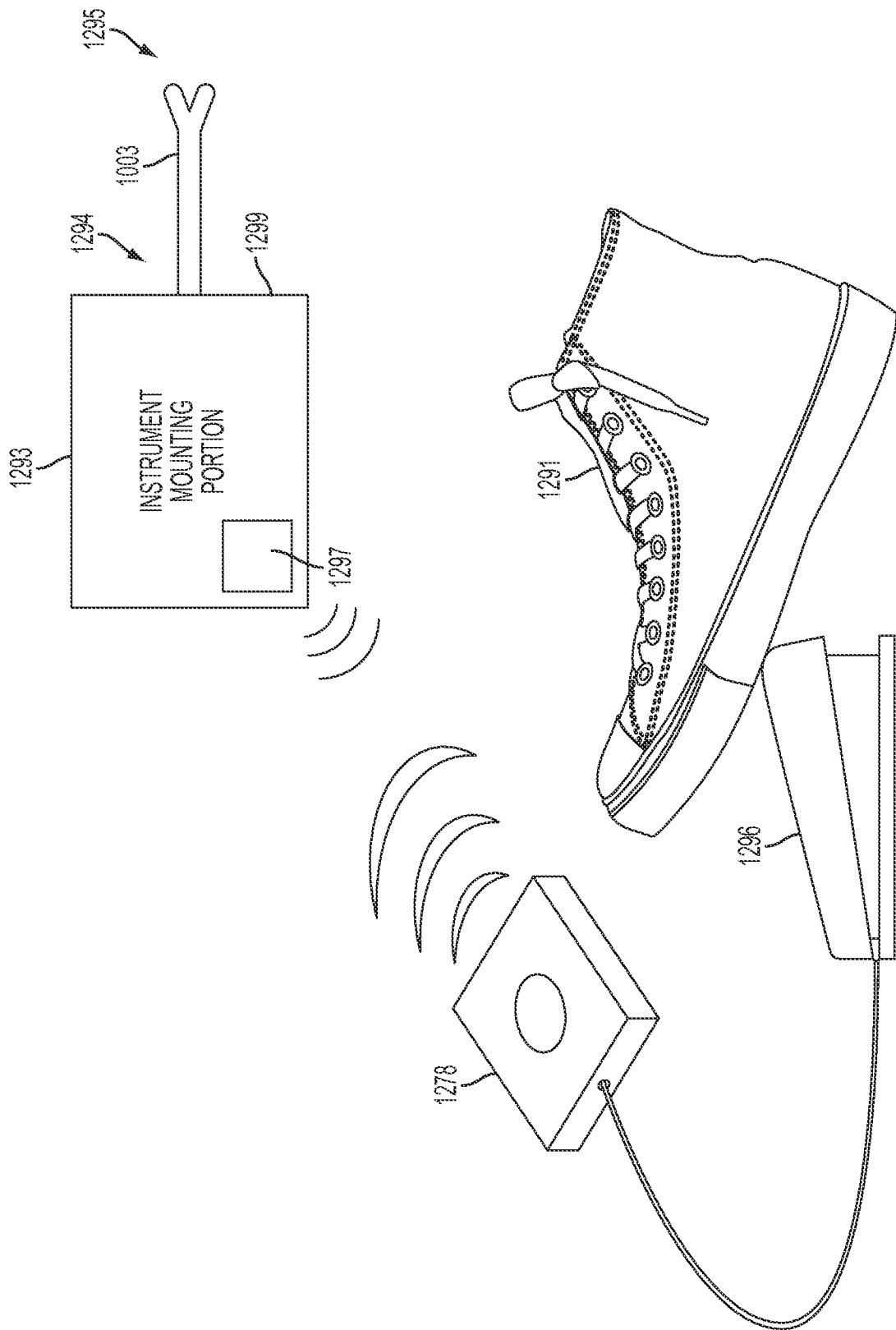

FIG. 77

73/76

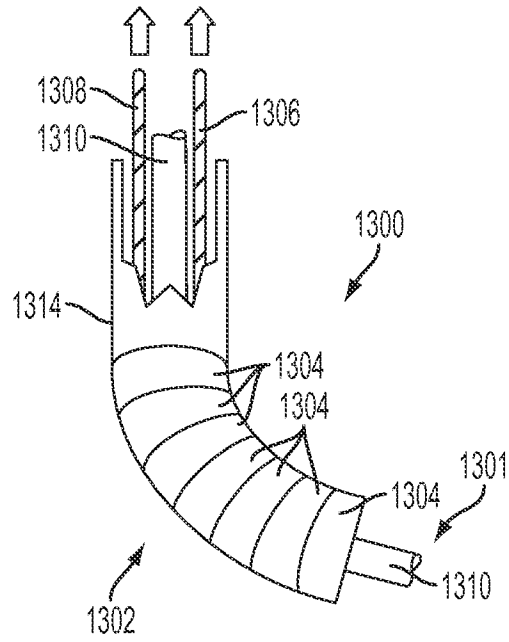

FIG. 78

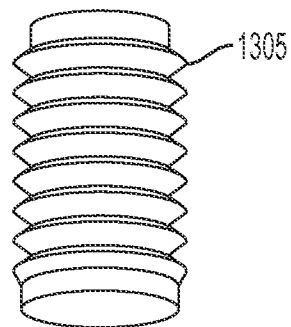

FIG. 79

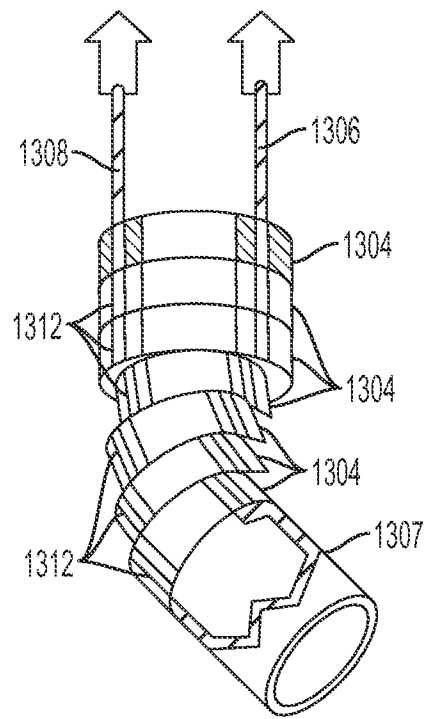

FIG. 80

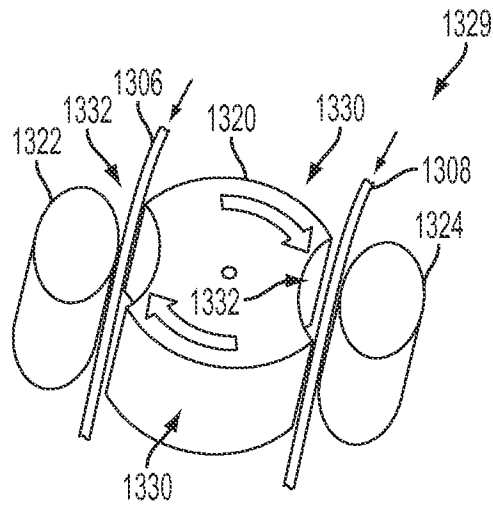

FIG. 81

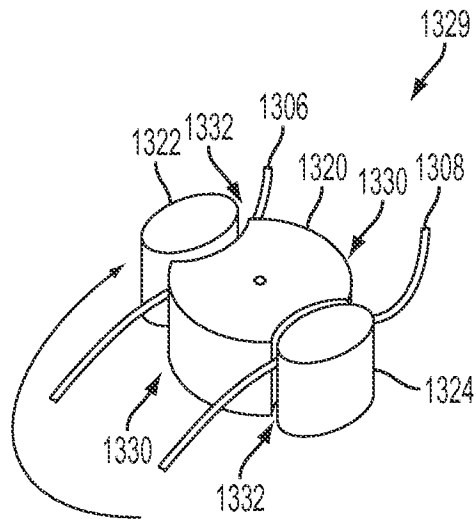

FIG. 82

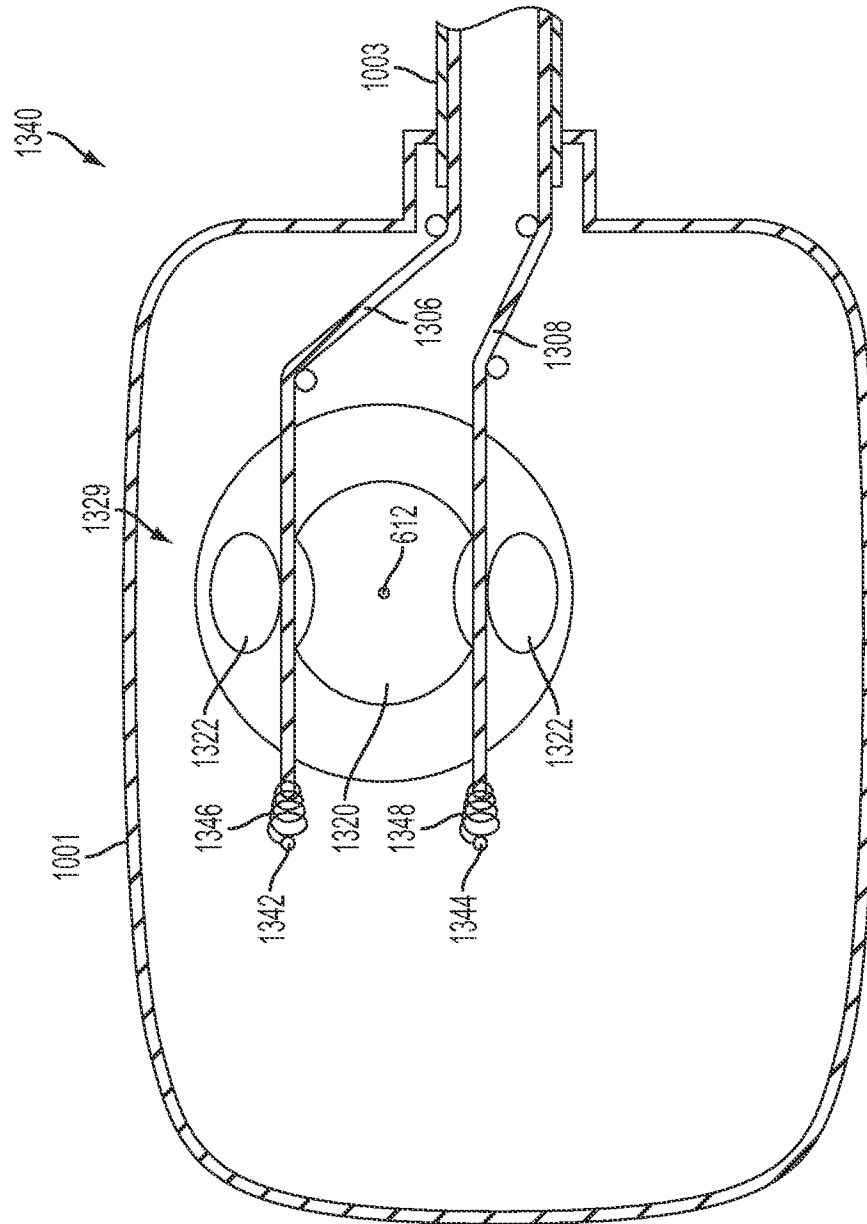

FIG. 83

INTERNATIONAL SEARCH REPORT

International application No
PCT/US2013/045641

A. CLASSIFICATION OF SUBJECT MATTER

INV. A61B19/00 A61B17/32 A61F9/007 A61B17/29
ADD.

According to International Patent Classification (IPC) or to both national classification and IPC

B. FIELDS SEARCHED

Minimum documentation searched (classification system followed by classification symbols)
A61B A61F

Documentation searched other than minimum documentation to the extent that such documents are included in the fields searched

Electronic data base consulted during the international search (name of data base and, where practicable, search terms used)

EPO-Internal, WPI Data

C. DOCUMENTS CONSIDERED TO BE RELEVANT

Category*	Citation of document, with indication, where appropriate, of the relevant passages	Relevant to claim No.
A	US 5 626 595 A (SKLAR MARTIN J [US] ET AL) 6 May 1997 (1997-05-06) column 3, line 37 - column 5, line 56; figures 1-4, 7 column 11, line 7 - line 17; figures 9-12 -----	1,21,22
A	US 2007/239170 A1 (BROCK DAVID L [US] ET AL) 11 October 2007 (2007-10-11) paragraph [0128] - paragraph [0146]; figures 42-49 -----	1,12,14
A	US 2002/188293 A1 (MANZO SCOTT [US]) 12 December 2002 (2002-12-12) paragraph [0065]; figures 14e-h ----- -/--	12,14

 Further documents are listed in the continuation of Box C. See patent family annex.

* Special categories of cited documents :

"A" document defining the general state of the art which is not considered to be of particular relevance

"E" earlier application or patent but published on or after the international filing date

"L" document which may throw doubts on priority claim(s) or which is cited to establish the publication date of another citation or other special reason (as specified)

"O" document referring to an oral disclosure, use, exhibition or other means

"P" document published prior to the international filing date but later than the priority date claimed

"T" later document published after the international filing date or priority date and not in conflict with the application but cited to understand the principle or theory underlying the invention

"X" document of particular relevance; the claimed invention cannot be considered novel or cannot be considered to involve an inventive step when the document is taken alone

"Y" document of particular relevance; the claimed invention cannot be considered to involve an inventive step when the document is combined with one or more other such documents, such combination being obvious to a person skilled in the art

"&" document member of the same patent family

Date of the actual completion of the international search

25 October 2013

Date of mailing of the international search report

06/11/2013

Name and mailing address of the ISA/

European Patent Office, P.B. 5818 Patentlaan 2
NL - 2280 HV Rijswijk
Tel. (+31-70) 340-2040,
Fax: (+31-70) 340-3016

Authorized officer

Moers, Roelof

INTERNATIONAL SEARCH REPORT

International application No
PCT/US2013/045641

C(Continuation). DOCUMENTS CONSIDERED TO BE RELEVANT		
Category*	Citation of document, with indication, where appropriate, of the relevant passages	Relevant to claim No.
A	US 2011/213361 A1 (CUNNINGHAM JAMES S [US] ET AL) 1 September 2011 (2011-09-01) paragraph [0040] - paragraph [0042]; figure 5	12,14
Y	----- US 5 897 523 A (WRIGHT JOHN C [US] ET AL) 27 April 1999 (1999-04-27) column 3, line 6 - column 6, line 6; figures 1-9	15-19
Y	----- US 5 359 994 A (KRAUTER ALLAN I [US] ET AL) 1 November 1994 (1994-11-01) column 3, line 9 - line 49; figures 1-5	15-19
A	----- US 2010/016852 A1 (MANZO SCOTT E [US] ET AL) 21 January 2010 (2010-01-21) paragraph [0042] - paragraph [0045]; figures 5a,b	15,18
A	----- US 2011/290853 A1 (SHELTON IV FREDERICK E [US] ET AL) 1 December 2011 (2011-12-01) paragraph [0342] - paragraph [0343]; figure 134	15
A	----- US 2007/173871 A1 (HOUSER KEVIN L [US] ET AL HOUSER KEVIN [US] ET AL HOUSER KEVIN L [US]) 26 July 2007 (2007-07-26) paragraph [0018] - paragraph [0021]; figures 1-5	15
A	----- US 2008/125628 A1 (UENO HARUHIKO [JP] ET AL) 29 May 2008 (2008-05-29) paragraph [0047] - paragraph [0064]; figure 3	15
A	----- US 6 440 062 B1 (OUCHI TERUO [JP]) 27 August 2002 (2002-08-27) column 3, line 23 - column 4, line 34; figure 2	15
X	----- US 2002/177843 A1 (ANDERSON STEPHEN C [US] ET AL) 28 November 2002 (2002-11-28)	20-22
Y	paragraph [0143] - paragraph [0158];	34-38
A	figures 20-24	29
A	----- US 2011/118756 A1 (BROCK DAVID L [US]) 19 May 2011 (2011-05-19) paragraph [0041]; figures 10, 11	21,22
Y	----- US 2008/255423 A1 (KONDO NOBUKO [JP] ET AL) 16 October 2008 (2008-10-16) paragraph [0065] - paragraph [0066]; figure 4	23-28
	----- -/--	

INTERNATIONAL SEARCH REPORT

International application No
PCT/US2013/045641

C(Continuation). DOCUMENTS CONSIDERED TO BE RELEVANT		
Category*	Citation of document, with indication, where appropriate, of the relevant passages	Relevant to claim No.
Y	US 2006/020287 A1 (LEE WOOJIN [US] ET AL) 26 January 2006 (2006-01-26) paragraph [0055]; figures 20, 21 -----	23-28
A	US 2010/004508 A1 (NAITO KIMIHIKO [JP] ET AL) 7 January 2010 (2010-01-07) paragraph [0092] - paragraph [0101]; figure 5a -----	23
A	US 2012/065628 A1 (NAITO KIMIHIKO [JP]) 15 March 2012 (2012-03-15) paragraph [0044]; figures 1-3 -----	23,26
A	US 2012/130366 A1 (CARROLL SEAN [US] ET AL) 24 May 2012 (2012-05-24) paragraph [0057] - paragraph [0063]; figure 2a -----	23
A	US 2011/184406 A1 (SELKEE THOMAS V [US]) 28 July 2011 (2011-07-28) paragraph [0035] - paragraph [0039]; figure 2b -----	23
Y	US 2010/030233 A1 (WHITMAN MICHAEL P [US] ET AL) 4 February 2010 (2010-02-04) paragraph [0036] - paragraph [0039]; figures 1-8 -----	29-33, 36-38 34,35
A	paragraph [0041] - paragraph [0043] paragraph [0049] - paragraph [0050] paragraph [0056]	
Y	US 6 666 875 B1 (SAKURAI TOMOHISA [JP] ET AL) 23 December 2003 (2003-12-23) column 4, line 12 - column 6, line 35; figures 1-4c -----	29-33 35
A	US 2008/140158 A1 (HAMEL ANDREW J [US] ET AL) 12 June 2008 (2008-06-12) paragraph [0039]; figures 1-3 -----	29
A	EP 2 365 608 A2 (TYCO HEALTHCARE [US]) 14 September 2011 (2011-09-14) abstract; figure 1 -----	29
Y	JP 2000 287987 A (OLYMPUS OPTICAL CO) 17 October 2000 (2000-10-17) paragraph [0018]; figure 2 -----	34,35 29
A	WO 02/062241 A1 (TYCO HEALTHCARE [US]; WISCONSIN ALUMNI RES FOUND [US]; ARANYI ERNEST []) 15 August 2002 (2002-08-15) page 4, line 22 - page 5, line 30; figure 1 -----	34,35
	-/--	

INTERNATIONAL SEARCH REPORT

International application No
PCT/US2013/045641

C(Continuation). DOCUMENTS CONSIDERED TO BE RELEVANT		
Category*	Citation of document, with indication, where appropriate, of the relevant passages	Relevant to claim No.
Y	US 2012/078278 A1 (BALES JR THOMAS O [US] ET AL) 29 March 2012 (2012-03-29) paragraph [0145] - paragraph [0148]; figures 3, 4 -----	36-38
A	US 2011/257650 A1 (DEVILLE DEREK DEE [US] ET AL) 20 October 2011 (2011-10-20) paragraph [0152] - paragraph [0153]; figure 42 -----	36,38
Y	US 2010/042077 A1 (OKADA YUTA [JP]) 18 February 2010 (2010-02-18) paragraph [0020] - paragraph [0022]; figures 1, 2 -----	39-41
Y	US 2003/233026 A1 (SAADAT VAHID [US] ET AL) 18 December 2003 (2003-12-18) paragraph [0053] - paragraph [0056]; figures 2, 3, 5, 6 paragraph [0062] - paragraph [0067] -----	39-41
A	US 2008/308607 A1 (TIMM RICHARD W [US] ET AL) 18 December 2008 (2008-12-18) paragraph [0212] - paragraph [0215]; figures 52-74 -----	39
A	EP 1 972 264 A1 (CODMAN & SHURTLEFF [US]) 24 September 2008 (2008-09-24) paragraph [0013]; figures 1-5 -----	40,41

INTERNATIONAL SEARCH REPORT

International application No.
PCT/US2013/045641

Box No. II Observations where certain claims were found unsearchable (Continuation of item 2 of first sheet)

This international search report has not been established in respect of certain claims under Article 17(2)(a) for the following reasons:

1. Claims Nos.:
because they relate to subject matter not required to be searched by this Authority, namely:

2. Claims Nos.:
because they relate to parts of the international application that do not comply with the prescribed requirements to such an extent that no meaningful international search can be carried out, specifically:

3. Claims Nos.:
because they are dependent claims and are not drafted in accordance with the second and third sentences of Rule 6.4(a).

Box No. III Observations where unity of invention is lacking (Continuation of item 3 of first sheet)

This International Searching Authority found multiple inventions in this international application, as follows:

see additional sheet

1. As all required additional search fees were timely paid by the applicant, this international search report covers all searchable claims.
2. As all searchable claims could be searched without effort justifying an additional fees, this Authority did not invite payment of additional fees.
3. As only some of the required additional search fees were timely paid by the applicant, this international search report covers only those claims for which fees were paid, specifically claims Nos.:
4. No required additional search fees were timely paid by the applicant. Consequently, this international search report is restricted to the invention first mentioned in the claims; it is covered by claims Nos.:

Remark on Protest

- The additional search fees were accompanied by the applicant's protest and, where applicable, the payment of a protest fee.
- The additional search fees were accompanied by the applicant's protest but the applicable protest fee was not paid within the time limit specified in the invitation.
- No protest accompanied the payment of additional search fees.

FURTHER INFORMATION CONTINUED FROM PCT/ISA/ 210

This International Searching Authority found multiple (groups of) inventions in this international application, as follows:

1. claims: 1-11

Surgical instrument for use with a robotic system having a magnetic element with a cable and a rotatable body with an actuation member.

2. claims: 12-14

Surgical instrument for use with a robotic system having first and second rotatable bodies with peg offsets.

3. claims: 15-19

Surgical instrument for use with a robotic system having a shaft with a joint, a waveguide with a bendable portion, helical cables and a gear.

4. claims: 20-22

Surgical instrument for use with a robotic system having a translatable ultrasonic transducer, waveguide and shaft.

5. claims: 23-28

Surgical instrument having a proximal and a distal tube with an articulation and a first articulation cable.

6. claims: 29-33

Surgical instrument for use with a robotic system having an end effector with an energy element, a rechargeable battery and an inductive coil.

7. claims: 34, 35

Surgical instrument for use with a robotic system having an end effector with an energy element and a power cord with a generator.

8. claims: 36-38

Surgical instrument for use with a robotic system having an end effector with an energy element and a removable battery.

FURTHER INFORMATION CONTINUED FROM PCT/ISA/ 210

9. claims: 39-41

Surgical instrument having a proximal and a distal tube with an articulation portion with a plurality of interfacing joints and first and second articulation cables.

INTERNATIONAL SEARCH REPORT

Information on patent family members

International application No
PCT/US2013/045641

Patent document cited in search report	Publication date	Patent family member(s)	Publication date
US 5626595	A	06-05-1997	NONE
US 2007239170	A1	11-10-2007	NONE
US 2002188293	A1	12-12-2002	US 2002188293 A1 12-12-2002 US 2006048787 A1 09-03-2006 US 2006079889 A1 13-04-2006 US 2010198218 A1 05-08-2010 US 2010198231 A1 05-08-2010
US 2011213361	A1	01-09-2011	EP 2361578 A2 31-08-2011 US 2011213361 A1 01-09-2011 US 2013253507 A1 26-09-2013
US 5897523	A	27-04-1999	US 5897523 A 27-04-1999 US 6090120 A 18-07-2000
US 5359994	A	01-11-1994	NONE
US 2010016852	A1	21-01-2010	US 2010016852 A1 21-01-2010 WO 2010009218 A2 21-01-2010
US 2011290853	A1	01-12-2011	US 2011290853 A1 01-12-2011 US 2012203247 A1 09-08-2012 WO 2012166465 A1 06-12-2012
US 2007173871	A1	26-07-2007	AU 2007207435 A1 26-07-2007 CA 2637916 A1 26-07-2007 CN 101394799 A 25-03-2009 EP 1993453 A2 26-11-2008 JP 5259420 B2 07-08-2013 JP 2009523559 A 25-06-2009 US 2007173871 A1 26-07-2007 US 2010042126 A1 18-02-2010 US 2013231691 A1 05-09-2013 WO 2007084731 A2 26-07-2007
US 2008125628	A1	29-05-2008	CN 1883368 A 27-12-2006 CN 201015585 Y 06-02-2008 EP 1913862 A1 23-04-2008 JP 2007000427 A 11-01-2007 US 2008125628 A1 29-05-2008 WO 2006137255 A1 28-12-2006
US 6440062	B1	27-08-2002	DE 10055726 A1 13-06-2001 US 6440062 B1 27-08-2002
US 2002177843	A1	28-11-2002	US 2002177843 A1 28-11-2002 US 2005021018 A1 27-01-2005
US 2011118756	A1	19-05-2011	NONE
US 2008255423	A1	16-10-2008	NONE
US 2006020287	A1	26-01-2006	US 2006020287 A1 26-01-2006 US 2010191278 A1 29-07-2010
US 2010004508	A1	07-01-2010	CN 101610724 A 23-12-2009

INTERNATIONAL SEARCH REPORT

Information on patent family members

International application No

PCT/US2013/045641

Patent document cited in search report	Publication date	Patent family member(s)	Publication date
		EP 2130504 A1	09-12-2009
		JP 5074069 B2	14-11-2012
		JP 2008237810 A	09-10-2008
		US 2010004508 A1	07-01-2010
		WO 2008120426 A1	09-10-2008

US 2012065628	A1 15-03-2012	CN 102821669 A	12-12-2012
		EP 2529658 A1	05-12-2012
		JP 5059231 B2	24-10-2012
		US 2012065628 A1	15-03-2012
		WO 2011145533 A1	24-11-2011

US 2012130366	A1 24-05-2012	AU 2010201269 A1	28-10-2010
		CA 2699536 A1	13-10-2010
		CN 101856271 A	13-10-2010
		EP 2241279 A1	20-10-2010
		IL 204664 A	31-07-2013
		JP 2010246914 A	04-11-2010
		US 2012130366 A1	24-05-2012

US 2011184406	A1 28-07-2011	AU 2011200226 A1	11-08-2011
		CA 2728803 A1	22-07-2011
		CN 102166136 A	31-08-2011
		EP 2347726 A2	27-07-2011
		EP 2431000 A2	21-03-2012
		JP 2011147783 A	04-08-2011
		US 2011184406 A1	28-07-2011
		US 2012259194 A1	11-10-2012

US 2010030233	A1 04-02-2010	AU 2009268582 A1	14-01-2010
		CA 2730240 A1	14-01-2010
		EP 2303139 A1	06-04-2011
		JP 2011527611 A	04-11-2011
		US 2010030233 A1	04-02-2010
		WO 2010006057 A1	14-01-2010

US 6666875	B1 23-12-2003	US 6666875 B1	23-12-2003
		US 2004116952 A1	17-06-2004

US 2008140158	A1 12-06-2008	NONE	

EP 2365608	A2 14-09-2011	NONE	

JP 2000287987	A 17-10-2000	NONE	

WO 02062241	A1 15-08-2002	AU 2002244082 B2	22-06-2006
		AU 2006220448 A1	19-10-2006
		CA 2437582 A1	15-08-2002
		EP 1435852 A1	14-07-2004
		EP 2000106 A1	10-12-2008
		EP 2221011 A2	25-08-2010
		ES 2317994 T3	01-05-2009
		ES 2346720 T3	19-10-2010
		ES 2373782 T3	08-02-2012
		JP 4152188 B2	17-09-2008
		JP 4896056 B2	14-03-2012
		JP 2004522523 A	29-07-2004
		JP 2008212693 A	18-09-2008

INTERNATIONAL SEARCH REPORT

Information on patent family members

International application No PCT/US2013/045641

Patent document cited in search report	Publication date	Patent family member(s)	Publication date
		JP 2012005851 A	12-01-2012
		WO 02062241 A1	15-08-2002
US 2012078278	A1	29-03-2012	NONE
US 2011257650	A1	20-10-2011	US 2011257650 A1
			US 2013245657 A1
			20-10-2011
			19-09-2013
US 2010042077	A1	18-02-2010	JP 5019108 B2
			JP 2008289556 A
			US 2010042077 A1
			WO 2008143218 A1
			05-09-2012
			04-12-2008
			18-02-2010
			27-11-2008
US 2003233026	A1	18-12-2003	AU 2003248699 A1
			EP 1585428 A2
			JP 2006505302 A
			JP 2009279412 A
			JP 2010000360 A
			US 2003233025 A1
			US 2003233026 A1
			US 2003233027 A1
			US 2003233056 A1
			US 2003233057 A1
			US 2003233058 A1
			US 2003233066 A1
			US 2006111614 A1
			WO 03105563 A2
			31-12-2003
			19-10-2005
			16-02-2006
			03-12-2009
			07-01-2010
			18-12-2003
			18-12-2003
			18-12-2003
			18-12-2003
			18-12-2003
			18-12-2003
			18-12-2003
			25-05-2006
			24-12-2003
US 2008308607	A1	18-12-2008	AT 483408 T
			CN 101327137 A
			EP 2005896 A2
			JP 2009028517 A
			US 2008308607 A1
			15-10-2010
			24-12-2008
			24-12-2008
			12-02-2009
			18-12-2008
EP 1972264	A1	24-09-2008	NONE