

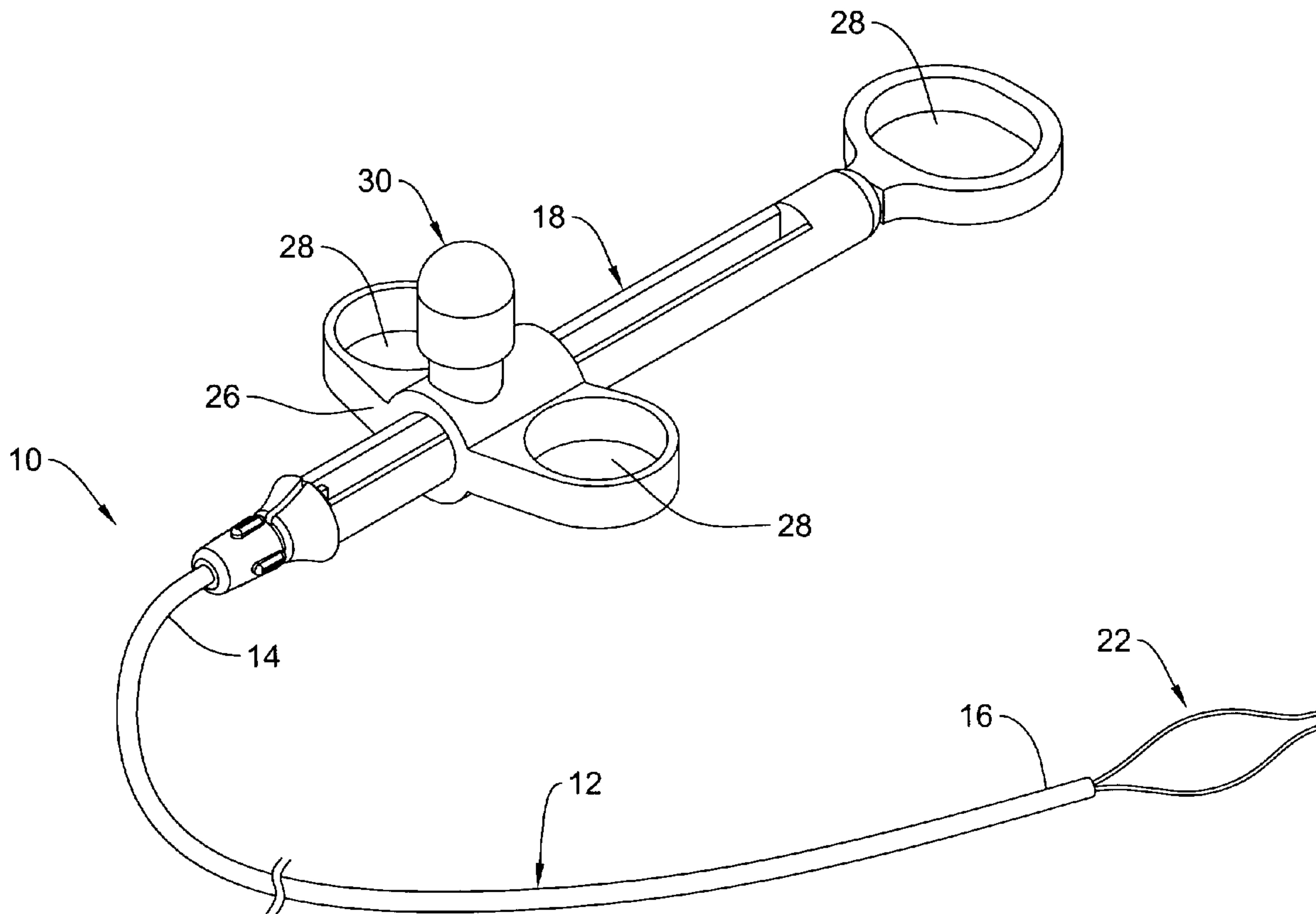

(86) Date de dépôt PCT/PCT Filing Date: 2004/11/16
 (87) Date publication PCT/PCT Publication Date: 2005/06/09
 (85) Entrée phase nationale/National Entry: 2006/05/15
 (86) N° demande PCT/PCT Application No.: US 2004/038451
 (87) N° publication PCT/PCT Publication No.: 2005/051210
 (30) Priorité/Priority: 2003/11/20 (US10/717,775)

(51) Cl.Int./Int.Cl. *A61B 17/32* (2006.01),
A61B 18/14 (2006.01)
 (71) Demandeur/Applicant:
BOSTON SCIENTIFIC LIMITED, BB
 (72) Inventeurs/Inventors:
GRIEGO, JOHN A., US;
CHIN, YEM, US
 (74) Agent: CASSAN MACLEAN

(54) Titre : DISPOSITIF D'ANSE A POLYPECTOMIE AUTO-ORIENTABLE
 (54) Title: SELF-ORIENTING POLYPECTOMY SNARE DEVICE



(57) **Abrégé/Abstract:**

A snare device and methods of making and using the same. The snare device may include a sheath having a proximal end region, a distal end region, and a shaft slidably disposed therein. A handle may be coupled to the shaft and disposed adjacent the proximal

(57) **Abrégé(suite)/Abstract(continued):**

end region. The snare device may also include a swivel disposed adjacent the distal end region of the sheath and coupled to the shaft and to a snare loop.

(12) INTERNATIONAL APPLICATION PUBLISHED UNDER THE PATENT COOPERATION TREATY (PCT)

(19) World Intellectual Property
Organization
International Bureau



(43) International Publication Date
9 June 2005 (09.06.2005)

PCT

(10) International Publication Number
WO 2005/051210 A1

- (51) International Patent Classification⁷: **A61B 17/32**, 01504 (US). **CHIN, Yem** [US/US]; 35 University Avenue, Burlington, Massachusetts 01803 (US).
18/14
- (21) International Application Number: PCT/US2004/038451
- (22) International Filing Date: 16 November 2004 (16.11.2004)
- (25) Filing Language: English
- (26) Publication Language: English
- (30) Priority Data: 10/717,775 20 November 2003 (20.11.2003) US
- (71) Applicant (for all designated States except US): **SCIMED LIFE SYSTEMS, INC.** [US/US]; ONE SCIMED PLACE, MAPLE GROVE, Minnesota 55311 (US).
- (72) Inventors; and
- (75) Inventors/Applicants (for US only): **GRIEGO, John A.** [US/US]; 46 Roberta Road, Blackstone, Massachusetts
- (74) Agent: **CROMPTON, David M., Agent;** CROMPTON, SEAGER & TUFTE, LLC, 1221 Nicollet Avenue, Suite 800, Minneapolis, Minnesota 55403 (US).
- (81) Designated States (unless otherwise indicated, for every kind of national protection available): AE, AG, AL, AM, AT, AU, AZ, BA, BB, BG, BR, BW, BY, BZ, CA, CH, CN, CO, CR, CU, CZ, DE, DK, DM, DZ, EC, EE, EG, ES, FI, GB, GD, GE, GH, GM, HR, HU, ID, IL, IN, IS, JP, KE, KG, KP, KR, KZ, LC, LK, LR, LS, LT, LU, LV, MA, MD, MG, MK, MN, MW, MX, MZ, NA, NI, NO, NZ, OM, PG, PH, PL, PT, RO, RU, SC, SD, SE, SG, SK, SL, SY, TJ, TM, TN, TR, TT, TZ, UA, UG, US, UZ, VC, VN, YU, ZA, ZM, ZW.
- (84) Designated States (unless otherwise indicated, for every kind of regional protection available): ARIPO (BW, GH, GM, KE, LS, MW, MZ, NA, SD, SL, SZ, TZ, UG, ZM, ZW), Eurasian (AM, AZ, BY, KG, KZ, MD, RU, TJ, TM), European (AT, BE, BG, CH, CY, CZ, DE, DK, EE, ES, FI, FR, GB, GR, HU, IE, IS, IT, LU, MC, NL, PL, PT, RO, SE,

[Continued on next page]

(54) Title: SELF-ORIENTING POLYPECTOMY SNARE DEVICE

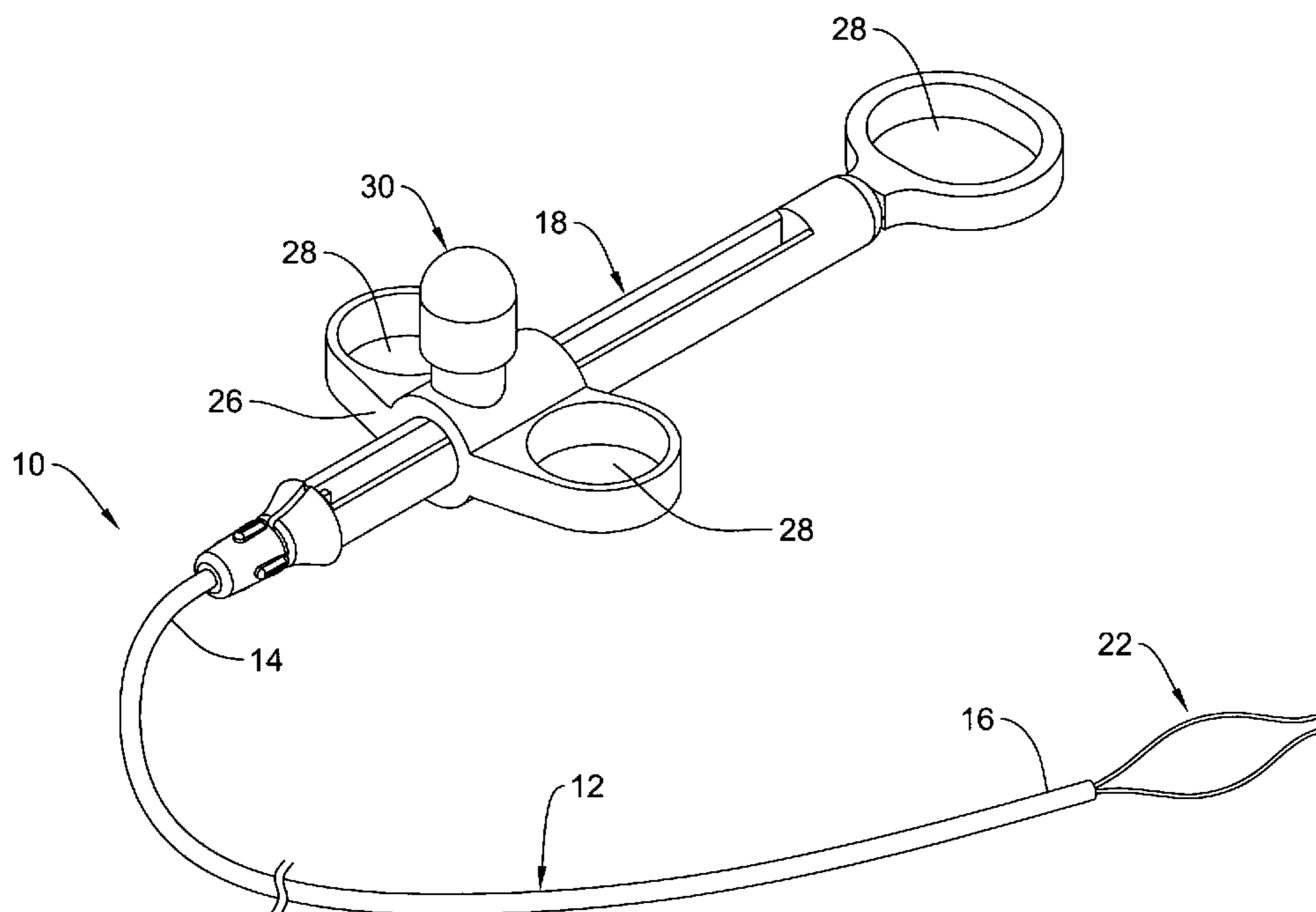

(57) Abstract: A snare device and methods of making and using the same. The snare device may include a sheath having a proximal end region, a distal end region, and a shaft slidably disposed therein. A handle may be coupled to the shaft and disposed adjacent the proximal end region. The snare device may also include a swivel disposed adjacent the distal end region of the sheath and coupled to the shaft and to a snare loop.

WO 2005/051210 A1

WO 2005/051210 A1



SI, SK, TR), OAPI (BF, BJ, CF, CG, CI, CM, GA, GN, GQ,
GW, ML, MR, NE, SN, TD, TG).

For two-letter codes and other abbreviations, refer to the "Guidance Notes on Codes and Abbreviations" appearing at the beginning of each regular issue of the PCT Gazette.

Published:

— *with international search report*

SELF-ORIENTING POLYPECTOMY SNARE DEVICE

Field of the Invention

The present invention pertains to a snare device for insertion in a body lumen
5 for removal of a tissue growth, such as a polyp. More particularly, the present
invention pertains to such a snare device that includes a self-orienting snare loop.

Background of the Invention

Polypectomy snare instruments are used for the endoscopic removal of
10 hypertrophic tissue growths within a body cavity, and particularly within the colon.
Polypectomy snare instruments generally include an elongate tubular member, such as
a catheter sheath, a shaft extending through the tubular member, a wire forming a
snare (loop) at the distal end of the shaft, and a handle for moving the shaft distally
and proximally within the tubular member. The snare can be opened by moving the
15 snare beyond the distal end of the sheath and closed by retraction of the snare into the
tubular member, each effected by movement of the shaft relative to the sheath. A
number of different types of snare devices exist, each having certain advantages and
disadvantages. There is an ongoing need for refined snare devices.

Summary of the Invention

20 The invention provides design, material, and manufacturing method
alternatives for medical devices, for example, snare devices. In at least some
embodiments, the snare devices include a sheath having a proximal end region, a
distal end region, and a shaft slidably disposed therein. A handle may be coupled to
25 the shaft and disposed adjacent the proximal end region of the sheath. The snare
device may also include a swivel disposed adjacent the distal end region of the sheath
and coupled to the shaft and to a snare loop. These and some of the other features and
characteristics of example embodiments are described in more detail below.

Brief Description of the Drawings

30 Figure 1 is a perspective view of an example snare device;

Figure 2 is a partial cross-sectional side view of an example snare device;

Figure 3 is a partial cross-sectional side view of another example snare device;

Figure 4 is a partial cross-sectional perspective view of an example swivel for use with a snare device;

Figure 5 is a partial cross-sectional perspective view of another example swivel for use with a snare device;

5 Figure 6 is a partial cross-sectional perspective view of another example swivel for use with a snare device; and

Figure 7 is a partial cross-sectional perspective view of another example swivel for use with a snare device.

10 Detailed Description of the Preferred Embodiments

The following description should be read with reference to the drawings wherein like reference numerals indicate like elements throughout the several views. The detailed description and drawings illustrate example embodiments of the claimed invention.

15 Figure 1 illustrates an example snare device 10. Snare device 10 may include an elongate sheath 12 having a proximal end region 14 and a distal end region 16. A handle 18 may be coupled to the proximal end region 14. A shaft member 20 may be disposed within at least a portion of sheath 12 and be slidable therein. A snare loop 22 may be coupled to shaft member 20, for example, by a swivel 24 (shaft member 20 and swivel 24 are not shown in Figure 1, but are seen in Figure 2). Swivel 24 allows snare loop 22 to be rotated independently of the rotation of shaft member 20. Accordingly, when snare loop 22 is used, for example to excise a polyp, the interaction of snare loop 22 with the polyp can result in rotation of snare loop 22 so that it can orient itself in a position for excising the polyp. The appropriate position
20 may be, for example, snare loop 22 disposed over and surrounding the polyp and disposed adjacent the base of the polyp. Thus, snare loop 22 is understood to be “self-orienting”, or in other words, capable of properly orienting itself relative to a polyp without the user needing to manipulate handle 18, shaft member 20, or some other proximally-disposed portion of snare device 10 to mechanically rotate snare loop 22
30 by manipulating handle 18.

By including a self-orienting snare loop 22, snare device 10 may be desirable over other types of snare devices. For example, rotation of typical snares usually includes rotating a shaft or cable at the proximal handle that extends along essentially the entire length of the snare device. Thus, the rotation of the snare loop in these

types of devices is dependent on the ability of the rotational forces applied to the cable at the handle (or some other proximal position) to transmit down the length of the device. Because the device may be disposed along a tortuous and sometimes lengthy path, rotation may not efficiently transmit. This could result in a “whipping effect” where the snare loop rapidly rotates with little or no control of the position of the loop. Moreover, these types of devices require that the shaft or cable used to rotate the snare loop be capable of transmitting torque. Therefore, the cable might need to have an increased outside diameter (which could increase the profile of the device) and to be sufficiently torque-transmitting (which could increase the manufacturing complexity and/or manufacturing costs).

Accordingly, in a preferred embodiments of snare device 10 there is included a swivel 24, which allows snare loop 22 to rotate independently of shaft 20 or with respect to shaft 20. In general, swivel 24 may be positioned adjacent to distal end region 16 of sheath 12 so that only a relatively short length of material rotates when snare loop 22 rotates. However, it may be desirable for swivel 24 to be set back proximally a distance so that even when snare loop 22 is configured for severing a polyp (i.e., when snare loop 22 extends distally from sheath 12), swivel 24 still remains within sheath 12. This embodiment may help reduce the possibility that swivel 24 may catch or become “hung up” on sheath 12 when snare loop 22 is proximally retracted.

The exact form of swivel 24 may vary and can include essentially any suitable form or type of swivel. Some examples of suitable swivels are described below and illustrated in Figures 4-6. These and other swivels including barrel swivels, ball and socket swivels, prismatic swivels (e.g., dodecahex swivels, large sqocta swivels, and small sqocta swivels), conic swivels (e.g., octonic swivels, pentonic swivels, and sqonic swivels), and the like, or any other suitable swiveling device are contemplated. It can be appreciated that a number of different swivels or swiveling means can be used without departing from the spirit of the invention.

Sheath 12 may be made from any suitable material including polymers, metals, metal alloys, metal-polymer composites, and the like. Some examples of suitable polymers may include polytetrafluoroethylene (PTFE), ethylene tetrafluoroethylene (ETFE), fluorinated ethylene propylene (FEP), polyoxymethylene (POM), polybutylene terephthalate (PBT), polyether block ester, polyurethane, polypropylene (PP), polyvinylchloride (PVC), polyether-ester (for example, a

polyether-ester elastomer such as ARNITEL® available from DSM Engineering
Plastics), polyester (for example, a polyester elastomer such as HYTREL® available
from DuPont), polyamide (for example, DURETHAN® available from Bayer or
CRISTAMID® available from Elf Atochem), elastomeric polyamides, block
5 polyamide/ethers, polyether block amide (PEBA, for example, available under the
trade name PEBAX®), silicones, polyethylene (PE), Marlex high-density
polyethylene, Marlex low-density polyethylene, linear low density polyethylene (for
example, REXELL®), polyethylene terephthalate (PET), polyetheretherketone
(PEEK), polyimide (PI), polyetherimide (PEI), polyphenylene sulfide (PPS),
10 polyphenylene oxide (PPO), polysulfone, nylon, perfluoro(propyl vinyl ether) (PFA),
other suitable materials, or mixtures, combinations, copolymers thereof,
polymer/metal composites, and the like. In some embodiments, sheath 12 can be
blended with a liquid crystal polymer (LCP). For example, the mixture can contain
up to about 5% LCP. By employing selection of materials and processing techniques,
15 thermoplastic, solvent soluble, and thermosetting variants of these and other materials
can be employed to achieve the desired results.

Shaft 20 may be made from any suitable material including polymers, metals,
metal alloys, metal-polymer composites, and the like. Some examples of suitable
polymers include any of those listed above. Some examples of suitable metals and
20 metal alloys include stainless steel, such as 304V, 304L, and 316L stainless steel;
nickel-titanium alloy such as linear-elastic or super-elastic nitinol, nickel-chromium
alloy, nickel-chromium-iron alloy, cobalt alloy, tungsten or tungsten alloys, MP35-N
(having a composition of about 35% Ni, 35% Co, 20% Cr, 9.75% Mo, a maximum
1% Fe, a maximum 1% Ti, a maximum 0.25% C, a maximum 0.15% Mn, and a
25 maximum 0.15% Si), hastelloy, monel 400, inconel 825, or the like; or other suitable
material.

Sheath 12, shaft 20, portions thereof, or other components of snare device 10
may also be doped with or otherwise include a radiopaque material. Radiopaque
materials are understood to be materials capable of producing a relatively bright
30 image on a fluoroscopy screen or another imaging technique during a medical
procedure. This relatively bright image aids the user of snare device 10 in
determining its location. Some examples of radiopaque materials can include, but are
not limited to, gold, platinum, palladium, tantalum, tungsten alloy, plastic material
loaded with a radiopaque filler, and the like. Alternatively, sheath 12 or other

components of snare device 10 may include other known marker bands, radiopaque coils, and the like.

Handle 18 may be made from any suitable material including any of those listed herein. Handle 18 may be disposed at proximal end region 14 of sheath 12 and be connected to (or adjacent) the proximal end of shaft 20. In general, handle 18 may serve as a graspable surface for device 10 and may be used to longitudinally move snare loop 22 relative to sheath 12. For example, handle 18 may include a sliding portion 26 that is attached to shaft 20 so that movement of sliding portion 26 (either distally or proximally) results in shaft 20 moving in the same longitudinal direction. Snare device 10 may be configured so that when sliding portion 26 and shaft 20 are slid or positioned distally (as shown in Figure 1), snare loop 22 may extend distally from sheath 12, where it is in a position for capturing and removing polyps. When sliding portion 26 and shaft 20 are slid or positioned proximally, snare loop 22 may be substantially collapsed and disposed within sheath 12.

Handle 18 may include a number of other structural features. For example, one or more finger holes 28 may be coupled to handle 18 and/or sliding portion 26 to help assist movement of sliding portion 28. Handle 18 may also include a port 30. Port 30 may be used, for example, as an access point to apply and/or deliver cautery current (including mono-polar and bipolar current) to shaft 20 and/or snare loop 22. It can be appreciated that a number of alterations can be made to the configuration and features of handle 18 without departing from the spirit of the invention.

In use, snare device 10 may be configured by proximally positioning sliding portion 26 of handle 18 so that snare loop 22 is collapsed and disposed within sheath 12. Device 10 can then be advanced through a body lumen to a suitable target location. In at least some embodiments, advancing device 10 may include passing sheath 12 through the working channel of an endoscope. Once inside the body lumen, sliding portion 26 can be slid distally to activate snare loop 22, whereby loop 22 emerges and becomes positioned distally of sheath 12. As snare loop 22 contacts the surface of the target site (e.g., a polyp) and a slight pressure is exerted, loop 22 can rotate about swivel 24 to the suitable position for "capturing" the polyp. In some instances, additional pressure may be used to lay snare loop 22 flat at the base of the polyp. When properly oriented, snare loop 22 can be retracted by proximally moving sliding portion 26. As loop 22 engages the distal end region 16 of sheath 12, the opening of loop 22 may reduce in size, thereby "squeezing" and, ultimately, severing

the polyp from the body. In some embodiments, cautery current (including monopolar and bipolar current) can be applied (e.g., at port 30 so that current flows along shaft 20 and into snare loop 22, which may help cauterize the area adjacent the newly severed polyp. After the appropriate number of polyps are severed, device 10 can be removed from the body.

The arrangement of shaft 20 relative to swivel 24 and snare loop 22 may vary. For example, Figure 2 is a partial cross-sectional side view of device 10, showing swivel 24 disposed between shaft 20 and a linking shaft 32. According to this embodiment, the proximal leg regions or legs 34 (in Figure 2 there are two legs indicated by reference numbers 34a and 34b) of snare loop 22 converge at and are connected to one another by a connector 36. Connector 36 is then connected to linking shaft 32, which extends to swivel 24. Accordingly, a first end region 35 of swivel 24 is connected to linking shaft 32 and a second end region 37 of swivel 24 is connected to shaft 12. In contrast, Figure 3 illustrates snare device 110, where legs 134a/134b of snare loop 122 are coupled directly to first end region 135 of swivel 124.

Figures 4-7 illustrate examples of suitable swivels that may be utilized with any of the snare devices disclosed herein. For the purpose of simplicity, these figures depict a single shaft (e.g., shaft 232 as shown in Figure 4) coupled to the distal end of the swivel. However, this single shaft is intended to represent embodiments where linking shaft 32 is used as well as when legs 34a/34b (or legs 134a/134b) are directly attached to the swivel. For example, Figure 4 shows swivel 224 having a swivel body 239. One or more bearings, for example a first bearing 238, second bearing 240, and a third bearing 242, may be disposed within swivel body 239. Shaft 232 may extend through bearing 238 and be slidable and/or moveable therein. Second bearing 240 may be coupled to the end of shaft 232 so as to prevent shaft 232 coming out of or otherwise disassociating from swivel 224. First bearing 238 may be fixed to body 239 and second bearing 240 may be rotatable within swivel body 239. According to this embodiment, shaft 232 (and, ultimately, snare loop 22) is rotatable by virtue of shaft 232 and second bearing 240 rotating as indicated by the arrow on bearing 240. Shaft 20 may be connected to third bearing 242. In some embodiments, third bearing 242 may be fixed to swivel body 239.

In other embodiments, such as the one illustrated in Figure 5, essentially the opposite arrangement may be used. For example, swivel 324 may include swivel

body 339, bearing 338, bearing 342 and another bearing 344. Shaft 332 may be connected to fixed bearing 338. Shaft 332 may be rotatable by virtue of swivel body 339 rotating about bearing 344 and shaft 20.

Figure 6 depicts another swivel 424 where both shaft 432 and shaft 20 are rotatable within swivel body 439. According to this embodiment, shaft 432 extends through bearing 438 and is connected to rotatable bearing 440. Similarly, shaft 20 extends through bearing 442 and is connected to bearing 444. By virtue of both shaft 432 and shaft 20 being configured to be rotatable, it can be appreciated that snare loop 22 can rotate independently of shaft 20.

Another swivel 524 is shown in Figure 7. Swivel 524 represents an example of a barrel swivel, which may be similar to the type of swivel commonly used by anglers to connect a hook, leader, or fishing lure to the end of a fishing line. Swivel 524 may include swivel body 539, first end region 535, a first stop or stopping member 546 disposed adjacent first end region 535, second end region 537, and a second stop or stopping member 548 disposed adjacent second end region 537. In general, one or both of stopping members 546/548 may be configured to be rotatable within swivel body 539 while preventing end regions 535/537 from becoming disassociated from swivel body 539. Shaft 532 may be coupled to first end region 535 and, thus, be rotatable. In some embodiments, shaft 20 is connected to second end region 537 and may (in addition to or as an alternative to the rotation of shaft 532) be rotatable.

It should be understood that this disclosure is, in many respects, only illustrative. Changes may be made in details, particularly in matters of shape, size, and arrangement of steps without exceeding the scope of the invention. The invention's scope is, of course, defined in the language in which the appended claims are expressed.

What is claimed is:

1. A surgical snare device including a tubular sheath (12) having a proximal end region (14) and a distal end region (16) and a shaft (20) extending through the sheath (12) and moveable therein, the surgical snare device further characterized by:

a swivel (24, 124, 224, 324, 424, 524) having a first end (37, 137, 537) and a second end (35, 135, 535), the first end (37, 137, 537) being coupled to the shaft (20); and

a snare loop (22, 122) coupled to the second end (35, 135, 535) of the swivel (24, 124, 224, 324, 424, 524).

2. The snare device of claim 1, wherein the swivel (24, 124, 224, 324, 424, 524) is configured to permit rotation of the snare loop (22, 122) relative to the shaft (20).

3. The snare device of claim 1, wherein the first end (37, 137, 537) of the swivel (24, 124, 224, 324, 424, 524) is coupled to a distal end of the shaft (20).

4. The snare device of claim 1, wherein the shaft (20) is moveable between a first position wherein the snare loop (22, 122) is substantially disposed within the sheath (12) and a second position wherein the snare loop (22, 122) substantially extends distally out of the distal end region (16) of the sheath (12).

5. The snare device of claim 1, wherein the snare loop (122) includes a plurality of proximal legs (134) that are connected to the second end (135) of the swivel (124).

6. The snare device of claim 1, wherein the snare loop (22) includes a plurality of proximal legs (34) that are connected to a connector (36).

7. The snare device of claim 6, further comprising a linking shaft (32) coupled to and extending between the connector (36) and the second end (35) of the swivel (24).

8. The snare device of claim 1, wherein the snare loop (22, 122) includes a braid.
9. The snare device of claim 1, wherein the swivel (24, 124) is one of the group including a barrel swivel, a ball and socket swivel, a prismatic swivel, and a conic swivel.
10. The snare device of claim 1, further comprising a handle (18) coupled to the proximal end region (14) of the sheath (12).
11. The snare device of claim 10, wherein the handle (18) includes one or more finger holes (28).
12. The snare device of claim 1, further comprising a cautery current flowing through the snare loop (22, 122).
13. The snare device of claim 12, wherein the cautery current includes a mono-polar or bi-polar current.
14. The snare device of claim 5 or 7, wherein the swivel (224, 324, 424, 524) includes a swivel body (239, 339, 439, 539).
15. The snare device of claim 14, wherein the swivel body (239, 339, 439) includes a first bearing (240, 344, 440, 444).
16. The snare device of claim 15, wherein the swivel body (239, 339, 439) includes a second bearing (238, 338, 438).
17. The snare device of claim 16, wherein the swivel body (239, 339, 439) includes a third bearing (242, 342, 442).
18. The snare device of claim 17, wherein at least one of the first, second and third bearings is rotatable within the swivel body (239, 339, 439).

19. The snare device of claim 15, wherein the first bearing (240, 344, 440, 444) is fixedly attached to the swivel body (239, 339, 439).

20. The snare device of claim 16, wherein the first bearing (240, 344, 440, 444) is rotatable within the swivel body (239, 339, 439) and the second bearing (238, 338, 438) is fixedly attached to the swivel body (239, 339, 439).

21. The snare device of claim 17, wherein the first bearing (240, 344, 440, 444) is rotatable within the swivel body (239, 339, 439) and the second bearing (238, 338, 438) and the third bearing (242, 342, 442) are fixedly attached to the swivel body (239, 339, 439).

22. The snare device of claim 15, wherein the snare loop (22, 122) is attached to the first bearing (240, 344, 440).

23. The snare device of claim 15, wherein the shaft (20) is attached to the first bearing (240, 344, 444).

24. The snare device of claim 15, wherein the linking shaft (32, 232, 332, 432) is attached to the first bearing (240, 344, 440).

25. The snare device of claim 15, wherein the proximal legs (134) are attached to the first bearing (240, 344, 440).

26. The snare device of claim 21, wherein the proximal legs (134) extend through the second bearing (238, 338, 438) and are attached to the first bearing (240, 344, 440).

27. The snare device of claim 21, wherein the linking shaft (32, 232, 332, 432) extends through the second bearing (238, 338, 438) and is attached to the first bearing (240, 344, 440).

28. The snare device of claim 21, wherein the shaft (20) extends through the third bearing (242, 342, 442) and is attached to the first bearing (240, 344, 444).

29. The snare device of claim 17, wherein the shaft (20) is attached to the third bearing (242, 342, 442).

30. The snare device of claim 29, wherein the third bearing (242, 342, 442) is fixedly attached to the swivel body (239, 339, 439).

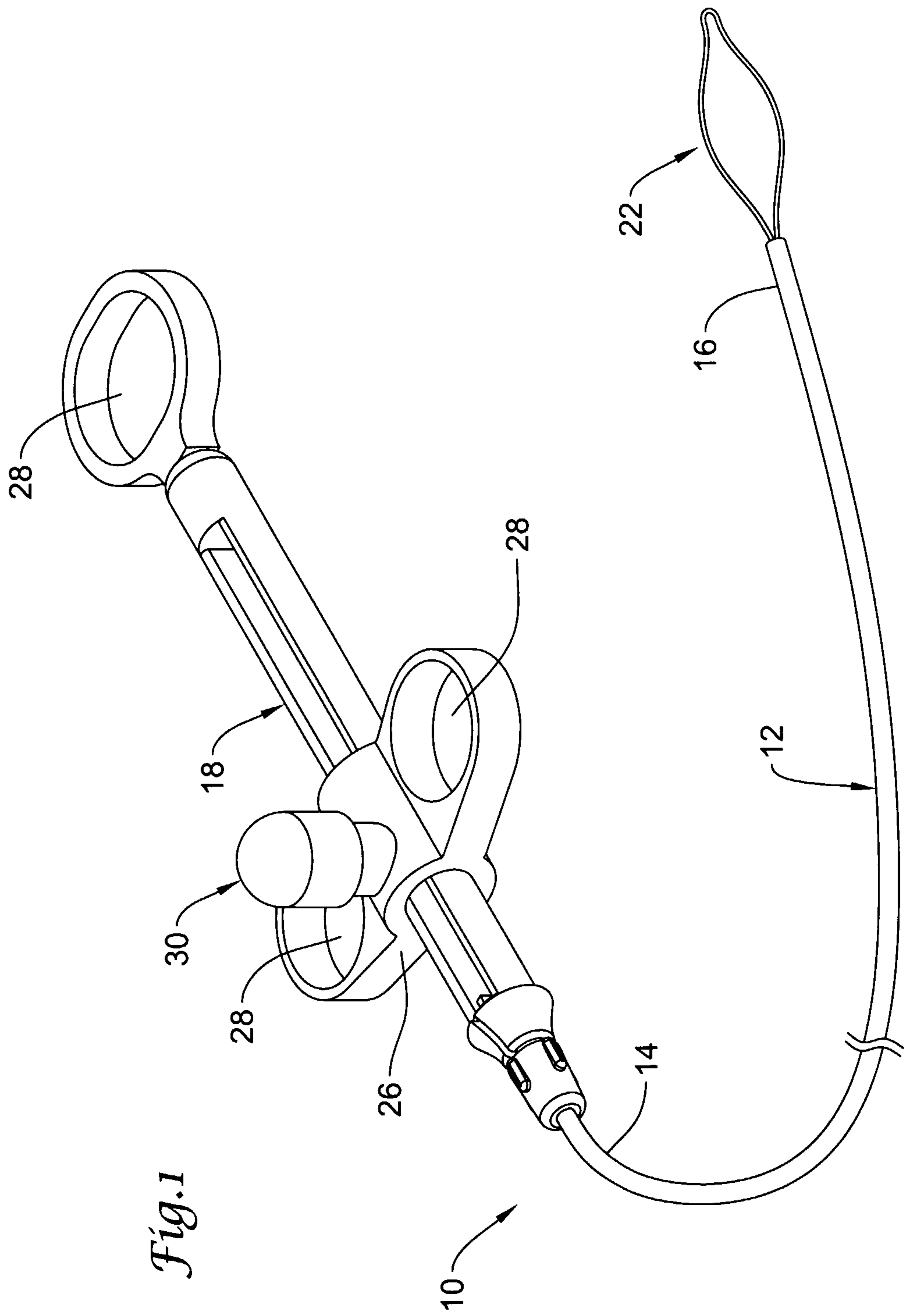

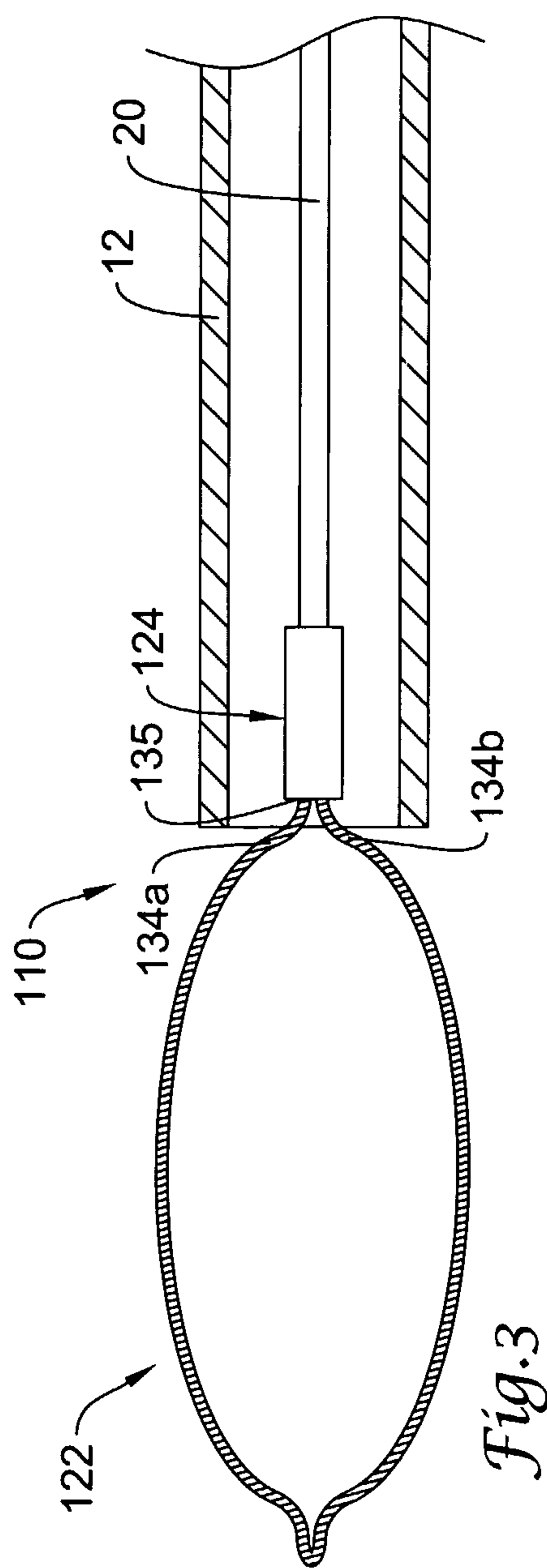
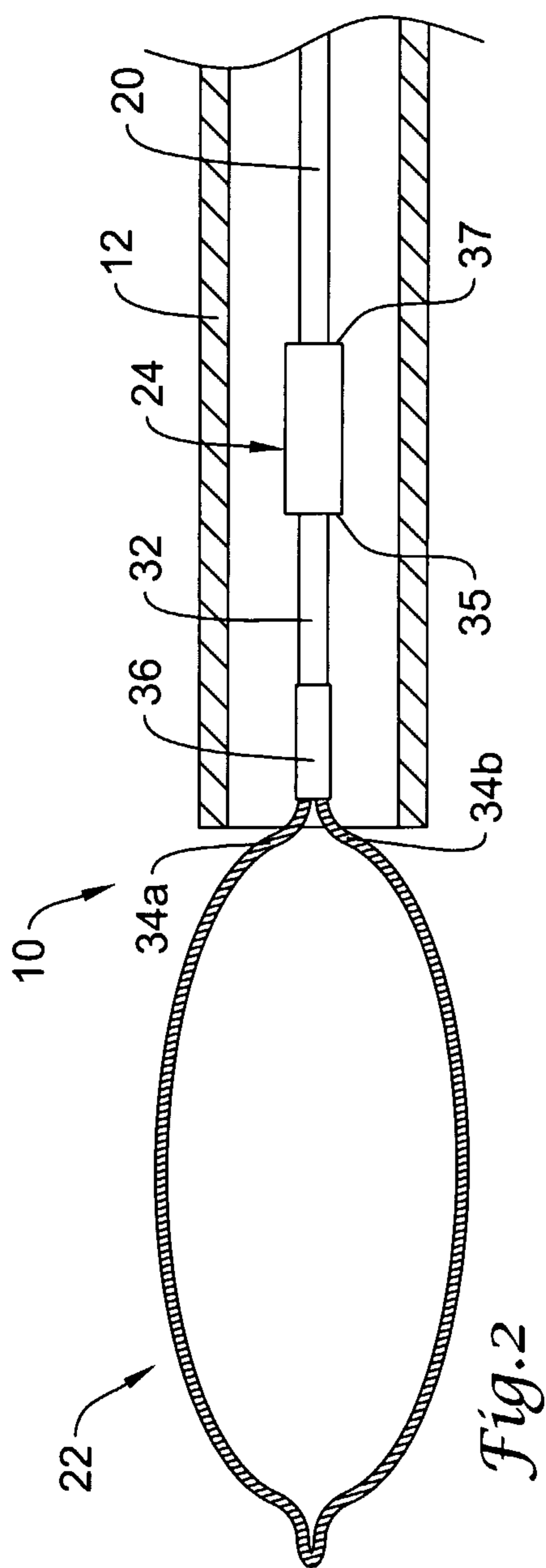

3/4

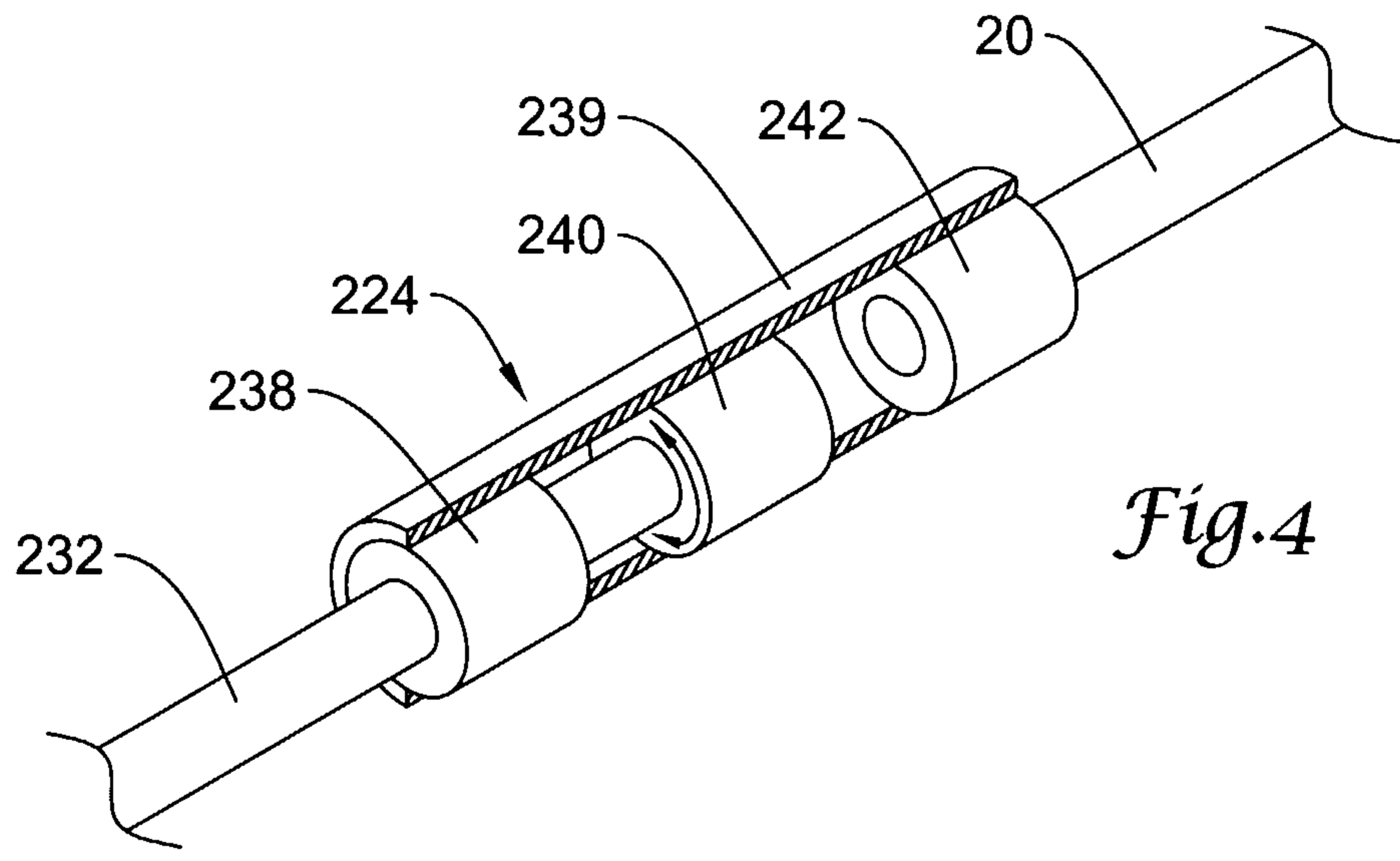

Fig. 4

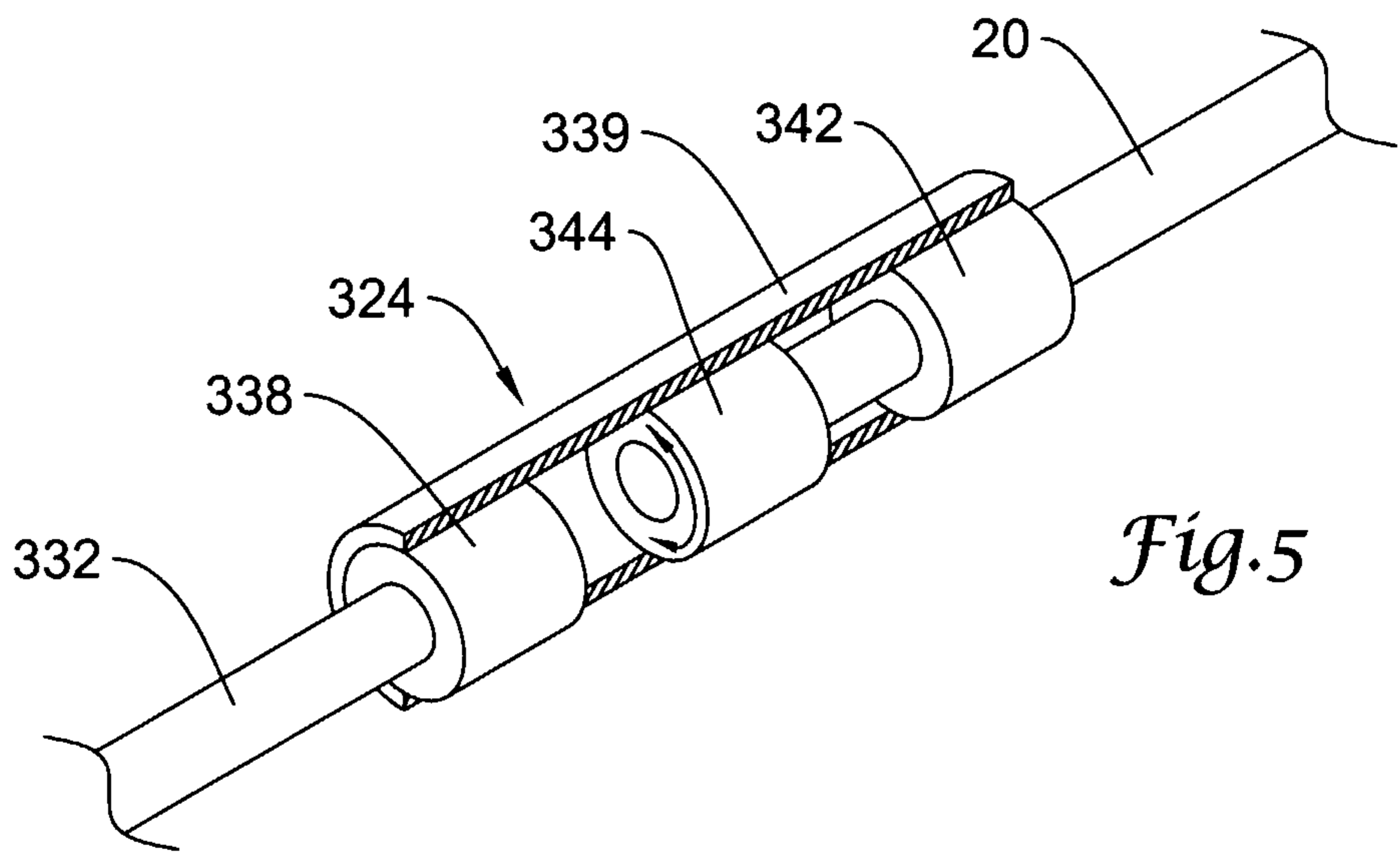

Fig. 5

4/4

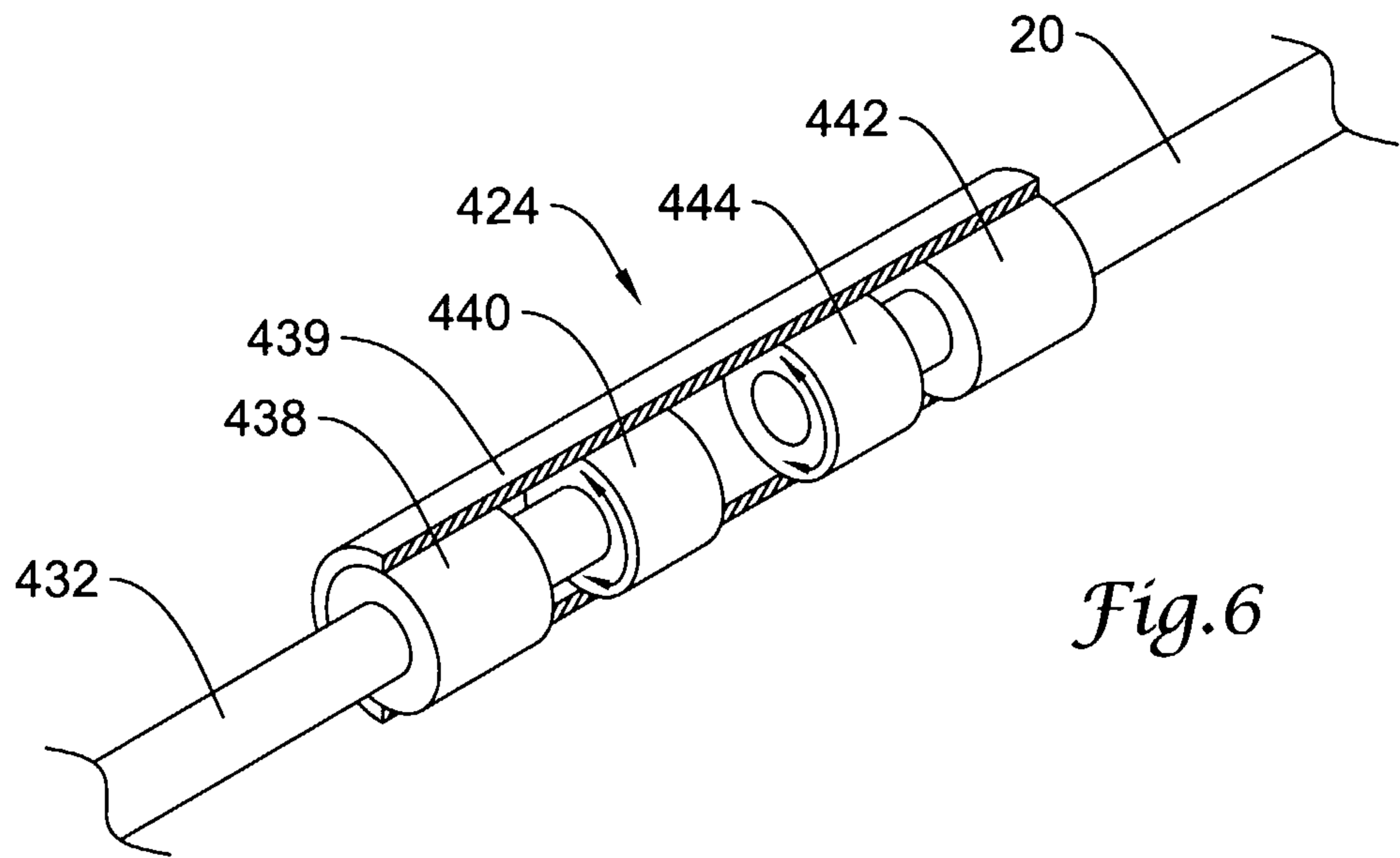

Fig. 6

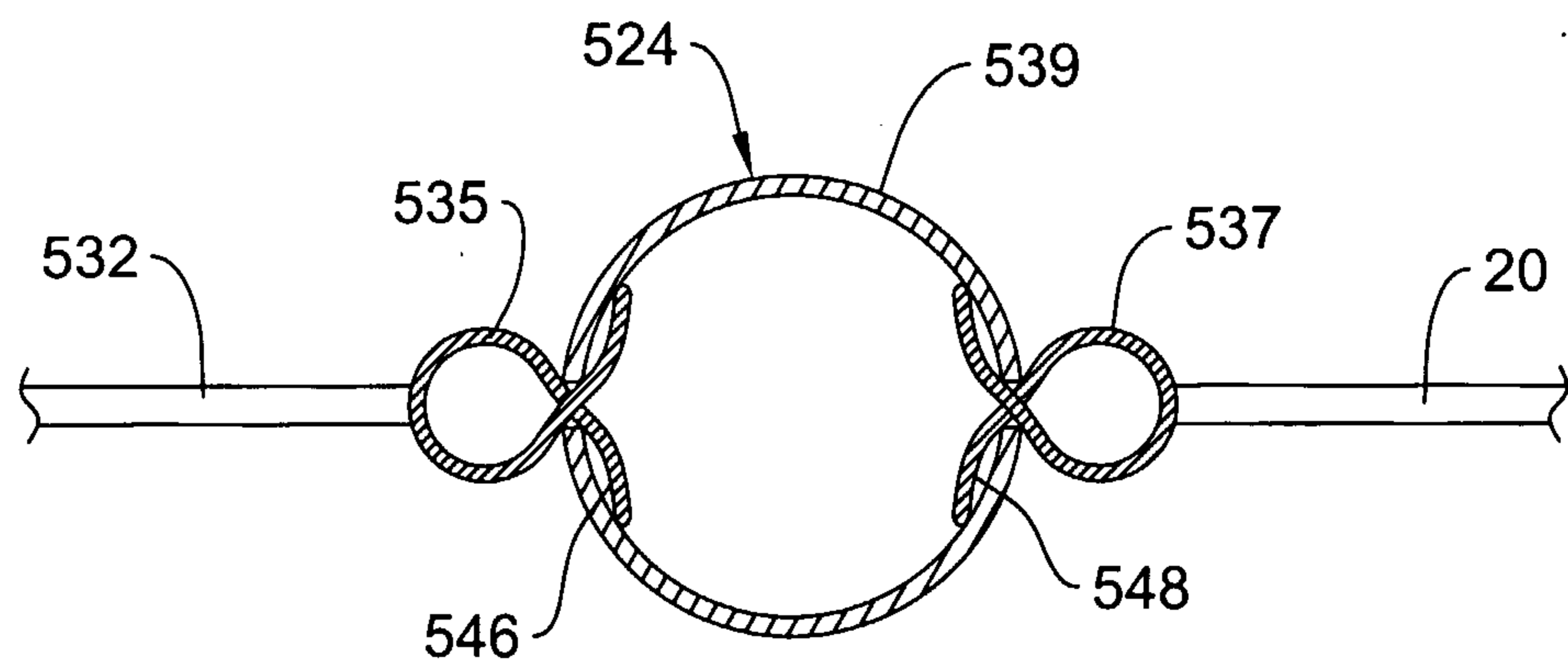

Fig. 7

