

W. H. Place,

Governor.

No. 105841.

Patented July 26, 1870.

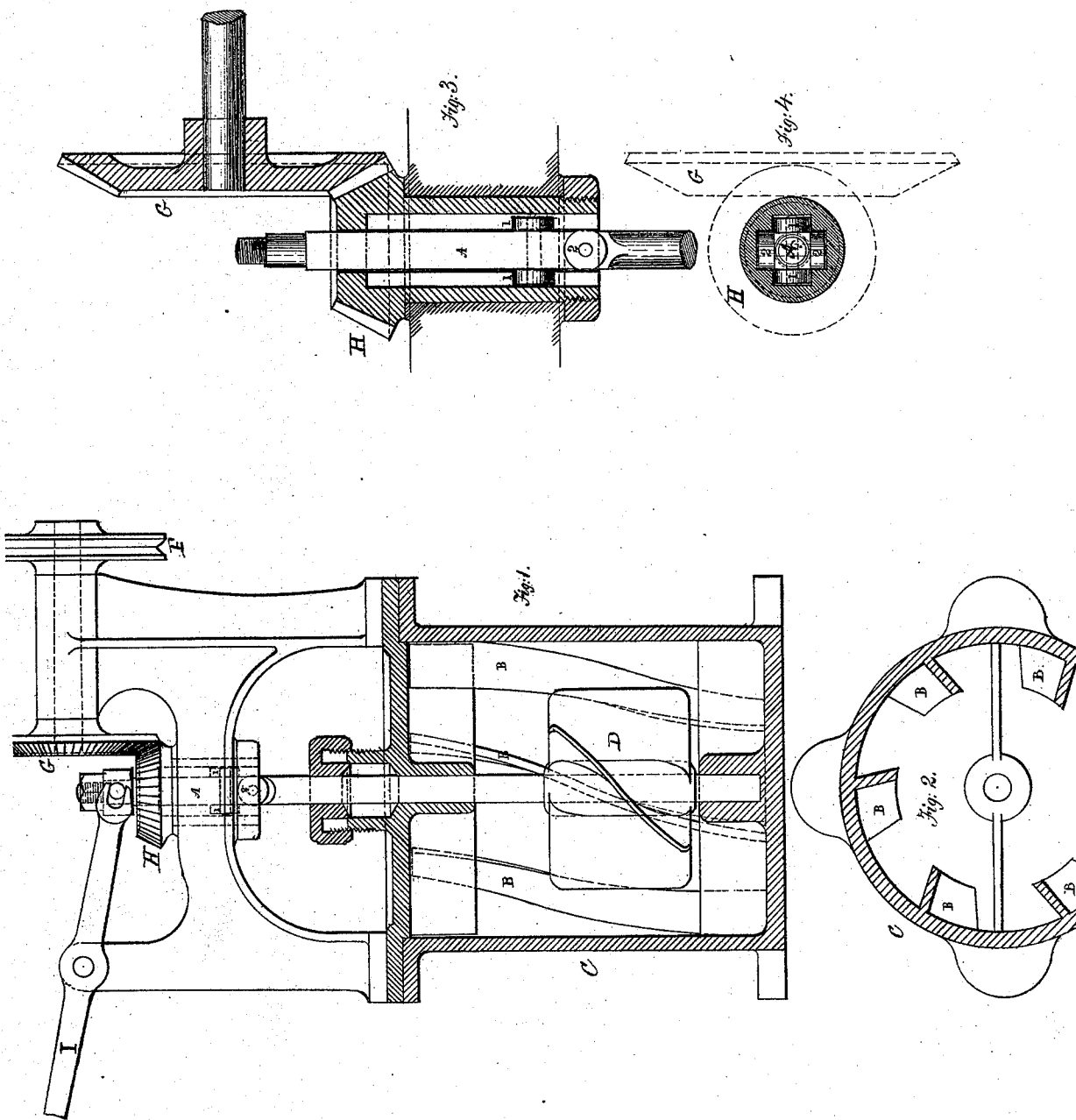

Witnesses  
Erasmus S. Low  
Wm. B. Lightfoot

Williams H. Place

# United States Patent Office.

WILLIAM H. PLACE, OF NEW YORK, N. Y.

Letters Patent No. 105,841, dated July 26, 1870.

## IMPROVEMENT IN STEAM-ENGINE GOVERNORS.

The Schedule referred to in these Letters Patent and making part of the same.

To all whom it may concern:

Be it known that I, WILLIAM H. PLACE, of the city, county, and State of New York, have invented certain new and useful Improvements in Governors for Steam-Engines; and I do hereby declare that the following is a full and exact description of the same, reference being had to the accompanying drawing and to the letters of reference marked thereon, in which—

Figure 1 is a vertical section;

Figure 2, a plan view;

Figure 3, a vertical section; and

Figure 4, a plan view.

Similar letters of reference are employed in each of the figured drawings.

My invention relates to that class of engine-governors which have a propeller or fan-wheel to govern and regulate the throttle-valve of a steam-engine, by the said propeller or fan-wheel moving in water or other liquid, and by which the increased or diminished rotation of the propeller or fan-wheel shall be so elevated or depressed as to close, in the one case, the throttle-valve, to check the motion of the engine, and in the other case to open the throttle-valve, to increase the motion of the engine; and

It consists—

First, in making, providing, and using, in the case of the governor, a series of inclined ribs, which are placed and located in an opposite direction to the direction of the propeller or fan-blades on the governing propeller; and

Second, in making, providing, and using, a series of friction-rolls on the stem or shaft of the propeller or fan-wheel, by which the movement of said stem or shaft is made so much easier that the said stem or shaft can be elevated or depressed (as required) in less time than could be effected otherwise; it being a requirement that the said movement should be made at the moment that a change in the motion of the engine is made, so that the change in the movement of the governor should immediately be transmitted to the throttle-valve. Unless this is done, the governor would be practically valueless.

C is the case of the governor, in which is placed the propeller or fan-wheel D, the propeller being operated from the engine to which the governor is attached by means of the pulley F, and gear-wheels G and H, the pulley F being operated from the main shaft of the engine to which the governor is attached, by means of a cord or belt, as shall be found most convenient.

A is the shaft driving the propeller or fan-wheel, which is provided with two sets of friction-wheels, 1 1

and 2 2, as shown, the purpose of these friction-wheels being to lessen the friction of the shaft A in its upward and downward movement through the space provided for it, so that it shall act more readily and quickly for the purpose desired than it would do if placed and operated in the same space without them.

B B, &c., are ribs placed in the interior of the case C, which are placed and located at such angle to the propeller-wheel D, and in opposite direction to the angle of the propeller-blades, that they tend to keep the water or other liquid, in the interior of the case C, during the rotation of the propeller-wheel D, in nearly a solid state, their purpose being to throw back onto the propeller-wheel D the water that is thrown off by the latter in its revolution, so as to effect the object before named.

I is a lever, attached by proper connection to the head of the shaft A, which is connected with the throttle-valve of the engine, for the purpose of controlling and governing the valve, and through that the motion of the engine.

The movement of the propeller-wheel D is so governed in relation to its connection with the throttle-valve of the engine, through the means named, as to close the throttle-valve when it reaches its highest point in the case C, and to open the same when it reaches its lowest point, the idea being that, when the governor is properly speeded, the governing power for a steady motion of the engine should be about midway of these two points.

I am aware that in the patent granted to Kenton K. Huntton, December 5, 1866, and reissued December 14, 1869, there are shown bars in the chamber when the propeller or fan-wheel is inclosed, but the bars, as shown, are made vertical, and do not and cannot effect the purposes of the spiral bars shown by me in the drawing, and described in this specification.

I therefore disclaim the right to the said bars, unless they are applied in the form and manner herein set forth.

What I claim as my invention, and desire to secure by Letters Patent, is—

1. The combination of the propeller-wheel D with the ribs B B B, &c., as shown and described and for the purposes set forth.

2. The friction-rollers 1 1 and 2 2, in combination with the shaft A, as for the purpose set forth.

WILLIAM H. PLACE.

Witnesses:

FRANCIS S. LOW,  
WM. A. LIGHTHALL.