

*I. V. Holmes,*  
*Steam Slide Valve.*

*N<sup>o</sup> 42, 191.*

*Patented Apr. 5, 1864.*

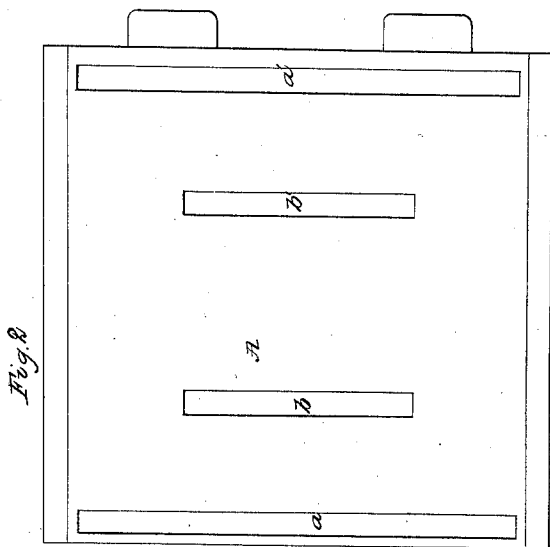

*Fig. 2*

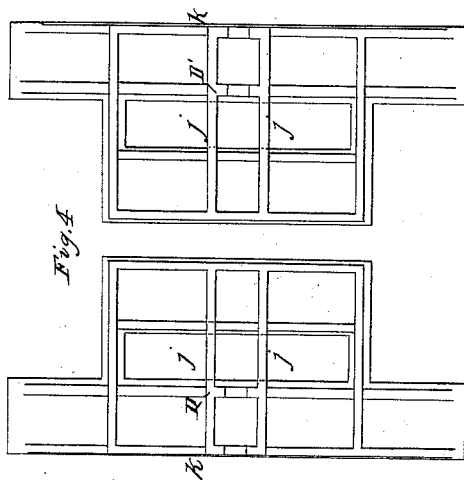

*Fig. 4*

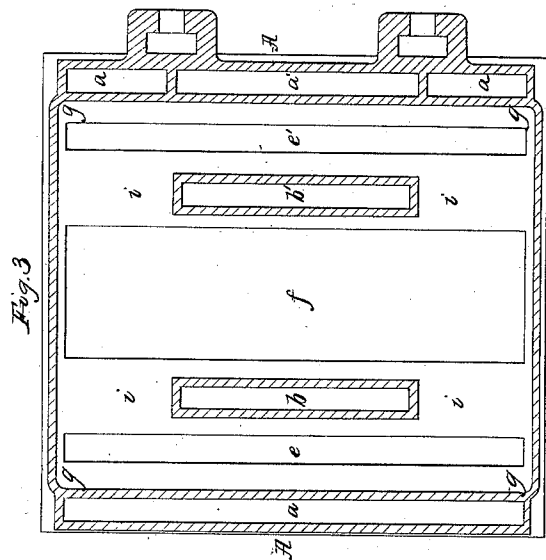

*Fig. 3*

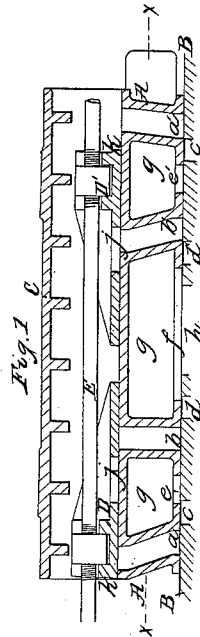

*Fig. 1*

*Witnesses*

*James D. Paul*  
*Geo. W. Reed*

*Inventor:*

*I. V. Holmes*

# UNITED STATES PATENT OFFICE.

ISAAC V. HOLMES, OF NEW YORK, N. Y.

## IMPROVEMENT IN SLIDE-VALVES FOR STEAM-ENGINES.

Specification forming part of Letters Patent No. 42,191, dated April 5, 1864.

*To all whom it may concern:*

Be it known that I, ISAAC V. HOLMES, of the city, county, and State of New York, have invented a new and useful Improvement in the Slide-Valves of Steam-Engines; and I do hereby declare that the following is a full, clear, and exact description of the same, reference being had to the accompanying drawings, forming part of this specification, in which—

Figure 1 is a longitudinal section of a slide-valve and riding cut-off valves in a plane perpendicular to its face. Fig. 2 is a back view of the valve. Fig. 3 is a section of the same, parallel with its face in the plane indicated by the line *x x* in Fig. 1. Fig. 4 is a plan of the cut-off valves.

Similar letters of reference indicate corresponding parts in the several figures.

In slide-valve steam-engines it is desirable, more especially in those of large size, to obtain a full opening of the port with the smallest practicable movement of the valve. To obtain this result it has been common to make the valve double-ported, but in making the valve double-ported, both for steam and exhaust, a difficulty has arisen—viz., the want of an effective mode of applying a cut-off, the arrangement of the ports having rendered it impracticable to apply a cut-off valve or valves riding directly on the back of the main valve.

This invention consists in the combination, with a slide-valve which is double-ported, both for steam and exhaust, of a cut-off valve or valves riding directly on the back thereof.

It also consists in a certain arrangement of the ports in such double-ported valve whereby the application of the cut-off valve or valves riding directly upon its back is made practicable.

To enable others skilled in the art to make and apply my invention, I will proceed to describe it with reference to the drawings.

A is the slide-valve, and B its seat. C, Fig. 1, is a cover secured to the back of the valve, and forming part of the means of balancing it, but not constituting part of the present invention. *a a' b b'* are the steam-ports of the valve for the induction of the steam to the cylinder—two at each end of the valve—extending through it from face to back, and *e e' d d'* are corresponding ports in the valve-seat. *e e' f* are the exhaust-ports in the

face of the valve, communicating with the cavity *g*, which extends as nearly as possible the entire length and width of the valve. The ports *e e'* operate in combination with the two ports *e e'* of the valve-seat, and the port *f* operates in combination with the two ports *d d'*, and also with the main exhaust-port *h* in the seat.

The ports *a a'*, *e e'*, and *f* are severally made of a length equal, or as nearly so as practicable, to the full width of the valve, but in order to provide for a free communication between the two exhaust-ports *e e'*, and the center exhaust port, *f*, and main exhaust-port *h*, the two ports *b b'* are made much shorter—say, only of about one-half that length—thereby making passages *i i* (see Fig. 3) at each end of the said ports, by which the steam exhausted through *e e'* finds its way to *f* and *h*. It is by this construction of the valve with short ports *b b'* and passages *i i'* that I am enabled to bring the four steam-ports all into the back of the valve, thereby permitting the application of the riding cut-off valves D D' directly upon the back of the double-ported valve, and reducing the capacity of the space between the cut-off valve and cylinder in the greatest practical degree.

Instead of the two ports *b b'*, arranged in the middle of the valve with a passage between them, there may be four ports of half the length—viz., two in place of *b* and two in place of *b'*—arranged close to the sides of the valve, with a passage between them for the exhaust-steam. This would be equivalent to the arrangement represented in the drawings.

The cut-off valves D D' are made each of a size and form shown in Fig. 4 to cover one of the longer steam-ports *a a'* and the corresponding shorter one *b* or *b'*, and with a port, *j*, arranged to uncover and cover the port *b* or *b'*, as the outer edge, *k*, of the valves uncovers and covers the corresponding port *a* or *a'*. The said cut-off valves are represented in Fig. 1 as attached to the same rod E. They may be adjusted and operated in the same manner as the riding cut-off valves applied on the back of a single-ported slide-valve.

The two cut-off valves may be combined so as to form literally but one valve, or they may be each divided into two, making one for each port; but the construction I have represented is the best, as it permits all the necessary ad-

justment without making the parts more numerous than is desirable.

What I claim as my invention, and desire to secure by Letters Patent, is—

1. The combination, with a slide-valve which is double-ported, both for steam and exhaust, of a cut-off valve or valves riding directly on the back thereof, substantially as herein specified.

2. The construction and arrangement of the several ports of a double-ported valve, substantially as described, whereby the steam ex-

hausted through two of the exhaust-ports *e e'* may pass the inner steam-ports, *b b'*, on its way to the main exhaust-port, substantially as herein described, and all the steam-ports are brought into the back of the valve, so that a cut-off valve or valves may be applied to ride directly thereon, substantially as herein specified.

ISAAC V. HOLMES.

Witnesses:

M. M. LIVINGSTON,  
J. W. COOMBS.