

(19)



Europäisches Patentamt
European Patent Office
Office européen des brevets



(11)

EP 0 758 122 A1

(12)

EUROPEAN PATENT APPLICATION

(43) Date of publication:
12.02.1997 Bulletin 1997/07

(51) Int Cl.⁶: G09F 9/37

(21) Application number: 96500109.2

(22) Date of filing: 25.07.1996

(84) Designated Contracting States:
AT BE CH DE DK ES FR GB GR IE IT LI LU MC NL
PT SE

(72) Inventors:
• Duek, Hugo Roberto
Buenos Aires (AR)
• Kogan, Hugo Alberto
Buenos Aires (AR)

(30) Priority: 27.07.1995 AR 33296195

(71) Applicants:
• Duek, Hugo Roberto
1425 Buenos Aires (AR)
• Duek, Gustavo Hugo
1416 Buenos Aires (AR)
• Bonessa, Carlos Miguel
1425 Buenos Aires (AR)

(74) Representative: Roeb Ungeheuer, Carlos et al
ROEB & CO., S.L.,
129, Paseo de la Castellana
28046 Madrid (ES)

(54) **Improvements in dynamic numbering devices for price indicators, parlour games and calendars**

(57) The improvements are applicable to the type of numbering device constituted around a base part (1) in which a series of housings (2) form a figure "8", housings (2) wherein corresponding indicator means (3) are duly mounted and secured and which present at least two contrasting surfaces (4) and (5), one of which corresponds to the shade and colour of the base part (1) surface. The indicator means (3) are rotational in their respective housings (2), allowing positional variations in

the chromatic bands fitted on said indicator means (3) in order to form various combinations for producing a permanent use dynamic numbering device. The indicator means may be constituted by parts movable in a straight line in their corresponding housings, as foreseen for said purpose in the base part.

The dynamic numbering device obtained is particularly applicable to the forming of price indicators, and for composing parlour games and selectively enabling the numbers in a calendar.

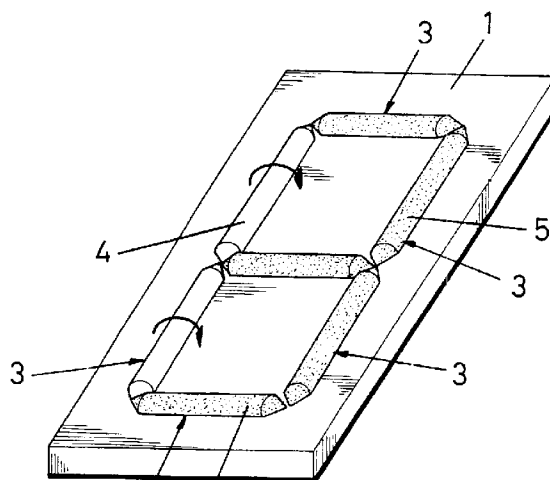

FIG.-1A

EP 0 758 122 A1

Description

OBJECT OF THE INVENTION

The present invention relates to improvements applicable to dynamic numbering devices for price indicators, parlour games, calendars and similar applications designed to provide a non-disposable, i.e. a permanent, numbering device devoid of loose parts and which furthermore offers a better view of the number being displayed.

BACKGROUND OF THE INVENTION

Several types of price indicator numbering devices are known, although all of them present a number of drawbacks which affect the function for which they were created.

Thus, numbering devices are known to consist of basic parts made of Bristol board or cardboard and which use sets of bars forming an "8" of a colour contrasting with that of the base part, generally white and black, respectively. The numbers are made up by painting the bars the same colour as the base.

This system presents a disadvantage in that the parts, once used, must be discarded. The materials for composing the parts are therefore very frail, as a result of which the numbering devices become deformed by heat, torn, blurred, etc., thus requiring the use of reinforcing elements on the base part, in addition to periodic replacement of the units affected because of their rapid wear, leading to increasing costs.

Other types of numbering devices are known based on Arabic numeral digits and fitted with grooves on the base part which also conform a figure "8", said grooves also providing a housing for replaceable complementary parts with opposing chromatic bands of contrasting colours.

This system also presents some serious inconveniences in that the replaceable parts are frequently lost, in addition to the wearing out of their perimeters or even the grooves in which they are lodged, as a result of which said replaceable parts fall off the numbering device and confuse the viewer.

DESCRIPTION OF THE INVENTION

The improvements of the invention are applicable to numbering devices with housings arranged to form an "8", although they also provide several features which solve the foregoing problems.

More specifically, the numbering device deriving from the improvements of the present invention is a permanent dynamic numbering device wherein the indicating means are mounted and kept in position in housings provided in the base part, said indicating means being movable and fitted with selectively enabled contrasting chromatic bands and allowing for changes in the num-

bering device digits through various combinations of the chromatic bands in the movable indicator means.

The parts comprising the indicator means cannot be lost since they are held in place by resilient fastening means; furthermore, falling off as a result of wear is prevented.

The indicator means may be rotationally movable, allowing for the installation of multiple chromatic bands of various colours, or they may be movable in a straight line, so that the price numbers are subject to as many changes as are necessary and are composed of as many colours as chromatic bands are included in the movable indicator means.

Furthermore, and because of the chromatic characteristics of the indicator means and the base part, numerous parlour games may be composed based on the unit's composition capacity and speed.

DESCRIPTION OF THE DRAWINGS

To complement this description and in order to provide a better understanding of the characteristics of the invention, a set of drawings is attached to this specification as an integral part thereof, wherein the following, of an illustrative and non-limiting character, is displayed:

Figure 1 is a schematic perspective view of a dynamic numbering device performed according to the object of the present invention, showing the rotational indicators inserted in the housings and arranged to form of an "8".

Figure 1A is another perspective view of the dynamic numbering device shown in the previous figure, illustrating the rotational movement of the indicator means which, when rotating, establish the chromatic change and define the number to be shaped.

Figure 2 is a cross-section detail of part of the rotational indicator, which, on being activated by the operator, rotates in the housing provided for that purpose in the corresponding base part.

Figure 3 is a view similar to that shown in figure 1, although the indicator means exhibit their chromatic band as having the same colour as the base part.

Figure 4 is a general perspective view of a rotational indicator means showing its formation and the two contrasting chromatic bands.

Figures 4A, 4B and 4C are respective end views of a rotational indicator means similar to the one shown in figure 4, although provided with two, three and four contrasting chromatic bands, respectively.

Figure 5 is a general perspective view of a dynamic numbering device in which the indicator means move in a straight line and are inserted in the corresponding housings, also forming an "8".

Figure 6 is a view of the dynamic numbering device shown in the previous figure, illustrating the straight line movement of the indicator means.

Figure 7 is a view similar to the one shown in figure 5, although with some of the indicator means exhibiting

their chromatic band in contrast with the base part.

Finally, figure 8 is a cross-section detail view of the indicator means shown in figures 5, 6 and 7, said indicator means being activated by the operator and moving in a straight line within the housing in the base part.

PREFERRED EMBODIMENT OF THE INVENTION

According to these figures, and more specifically to figures 1 to 4, the dynamic numbering device is seen to be structured from a base part (1) provided with housings (2) constructed in such a manner that between them they form a figure "8", as shown clearly in figures 1, 2 and 3, each of said housings corresponding to an Arabic numeral digit. Thus, in each of said housings (2) are mounted indicator means (3) fitted with contrasting and selectively enabled chromatic bands (4) and (5), at least one of said chromatic bands (4) presenting the same appearance and colour as that of the base part (1) surface.

Each indicator means (3) is mounted to be rotationally movable, for which purpose the housings (2) define an elongated cavity of a curving shape, while the indicator means (3) are cylindrically shaped with pointing or conical ends (6) and are secured in the housings (2) by flexible fastening means (7), as shown in figure 2, their removal being thus impaired although their rotational movement is allowed in order to alternatively expose the various contrasting faces or chromatic faces, these being light-dark, bright-dull, or a chromatic band.

Figures 1A and 2 show the indicator means (3) with two chromatic bands (4) and (5) performed in a longitudinal direction and having a contrasting appearance and colour so that one of said bands, as previously stated, has the same appearance and colour as the surface of the base part (1), in order that, when they coincide, their colouring mingles and the presence of the indicator means passes unnoticed, whereas when the chromatic band (5) of the indicator means (3) has an appearance and colour contrasting with the chromatic band of the surface of the base part (1), the difference between both surfaces is clearly evident.

Figures 4A, 4B and 4C illustrate the indicator means (3), which includes two chromatic and longitudinal bands (4) and (5), three longitudinal bands (4), (5) and (5'), or four chromatic bands (4), (5), (5') and (5''), respectively, in a manner that in each of these cases the respective housing (2) acquires a shape that is complementary with the indicator means (3), i.e. the housings (2) are of various sizes, depending on the width of the chromatic bands (4), (5), (5') and (5''). Therefore, the more chromatic bands in the indicator means (3), the narrower the opening of the corresponding housing (2) will have to be so that the longitudinal edges of the positioned chromatic band itself coincide with the longitudinal edges of the opening in housing (2).

In a second version of the embodiment, shown in figures 5 to 8, the indicator means (3') is arranged in the

corresponding housing (2') of the base part (1'), in this case, characteristic in that the indicator means (3') is an elongated, flat, rectangular part movable inside the corresponding housing (2') and having a manually operated protrusion (8), movable by finger (9) pressure, said protrusion (8) acting on a window or groove (10) provided for that purpose on the base plate (1'), the ends of the window or groove (10) providing a limit to the movement of the indicator means (3'), the length of the latter being greater than that of the window or groove (10).

The indicator means (3') is fitted with a front chromatic band which may be in contrast with the chromatic band corresponding to base part (1'), the chromatic band of the indicator means (3') furthermore having the same appearance and colour as that of the surface corresponding to the bottom (11) of the housing (2').

According to the features described, operation is as follows:

In the case of the embodiment shown in figures 1 to 4, the rotationally movable indicator means (3) are secured in their corresponding housings (2) by flexible fasteners (7) and are allowed rotational movement.

Each indicator means (3) is provided with at least two different chromatic bands (4) and (5) which are liable to be rotatingly and selectively enabled, and, since additionally the appearance and colour of the chromatic band (4) is the same as that of the base part (1) surface, various combinations are possible whereby, while some indicator means (3) are in contrast with the base part (1), others blend with it.

Furthermore, the housing (2) arrangements which form an "8" figure allow the operator (9) to form various Arabic numeral digits, each digit corresponding to a specific combination of the chromatic bands (4) and (5) and their indicator means (3).

In the event that each rotational indicator means (3) is provided with more than two chromatic bands, selectively enabled and of different colours, like the case illustrated in figures 4B and 4C, the operator is able to compose the digits of the dynamic numbering device using as many colours as contrasting chromatic bands are provided in each indicator means (3).

Concerning the embodiment illustrated in figures 5 to 8, the straight-line movable indicator means (3') is fitted with a front contrasting chromatic band which is visible through window (10) providing access to housing (2'), the digits being composed simply by moving each indicator means (3') in a straight line by pressing on the protrusion or extension (8) thereon. In this case, the operator (9) is able to select the alternative position, in which the indicator means (3') is covered by the front wall of base part (1'), so that, through the opening or window (10), the bottom surface (11) of housing (2') can be perceived to have the same colour or texture as the surface of base part (1').

In this case also, digits may be conformed by combining different positions of the indicator means (3').

It is evident that in multiple other forms of embodi-

ment the dynamic numbering device described herein may present different structures allowing parlour games to be composed, particularly in the case of rotating indicator means (3) fitted with several chromatic bands (5), (5'), (5'') of various contrasting colours. Based on this same principle, the dynamic numbering device may be used to selectively enable the numbers in a calendar.

Claims

1. Improvements in dynamic numbering devices for price indicators, parlour games and calendars of the type embodied around a base part (1-1') provided with housings (2-2') to form groups in the shape of a figure "8" corresponding to Arabic numeral digits and whose housings (2-2') are designed to receive the mounting of corresponding indicator means with contrasting surfaces or faces which are selectively enabled, at least one of said surfaces or faces showing the same appearance and shade as the base part (1-1'), characterized in that the indicator means (3-3') are movably mounted within their corresponding housings (2-2') and are positionally secured within them, their removal being thus impaired. 5
2. Improvements in dynamic numbering devices for price indicators, parlour games and calendars, according to claim 1, characterized in that the indicator means (3) are mounted in a manner that they are rotatably movable. 10
3. Improvements in dynamic numbering devices for price indicators, parlour games and calendars, according to claim 1, characterized in that the indicator means (3') are mounted in a manner that they are movable in a straight line, and alternatively in a transverse direction, in respect to the base part (1'). 15
4. Improvements in dynamic numbering devices for price indicators, parlour games and calendars, according to claim 1, characterized in that the indicator means (3') are mounted in a manner that they are movable in a straight line, and alternatively in a longitudinal direction, in respect to the base part (1'). 20
5. Improvements in dynamic numbering devices for price indicators, parlour games and calendars, according to claim 2, characterized in that each indicator means (3) is a fusiform part. 25
6. Improvements in dynamic numbering devices for price indicators, parlour games and calendars, according to claims 1, 2 and 5, characterized in that each indicator means (3) is positionally secured by hinged fastening means (7) correspondingly provided in the housings (2) of base part (1). 30
7. Improvements in dynamic numbering devices for price indicators, parlour games and calendars, according to claim 1, characterized in that the indicator means (3) are fitted with at least two chromatic bands (4) and (5) in contrast to one another. 35
8. Improvements in dynamic numbering devices for price indicators, parlour games and calendars, according to claim 7, characterized in that one of the chromatic bands (4) of the indicator means (3) is the same colour as the proximal surface of base part (1). 40
9. Improvements in dynamic numbering devices for price indicators, parlour games and calendars, according to claim 2, characterized in that the indicator means (3) is an approximately cylindrical part. 45
10. Improvements in dynamic numbering devices for price indicators, parlour games and calendars, according to claims 2, 5 and 9, characterized in that the indicator means (3) is fitted with multiple chromatic bands of different colours (4), (5), (5'), (5''). 50
11. Improvements in dynamic numbering devices for price indicators, parlour games and calendars, according to claim 10, characterized in that the opening in the housing (2) is of a width such that the longitudinal edges of the positioned chromatic band coincide with the longitudinal edges of said opening. 55
12. Improvements in dynamic numbering devices for price indicators, parlour games and calendars, according to claim 1, characterized in that the indicator means (3-3') are provided with at least two contrasting surfaces, alternatively enabled through the movement of said means within their own housing (2-2') in base part (1-1'), one of said surfaces being of a texture and shade equivalent to that of the base part (1) itself.
13. Improvements in dynamic numbering devices for price indicators, parlour games and calendars, according to claim 12, characterized in that the contrasting surfaces present a clear-dark contrast.
14. Improvements in dynamic numbering devices for price indicators, parlour games and calendars, according to claim 12, characterized in that the contrasting surfaces present a bright-dull contrast.
15. Improvements in dynamic numbering devices for price indicators, parlour games and calendars, according to claim 1, characterized in that the indicator means (3-3') are provided with at least two contrasting surfaces.

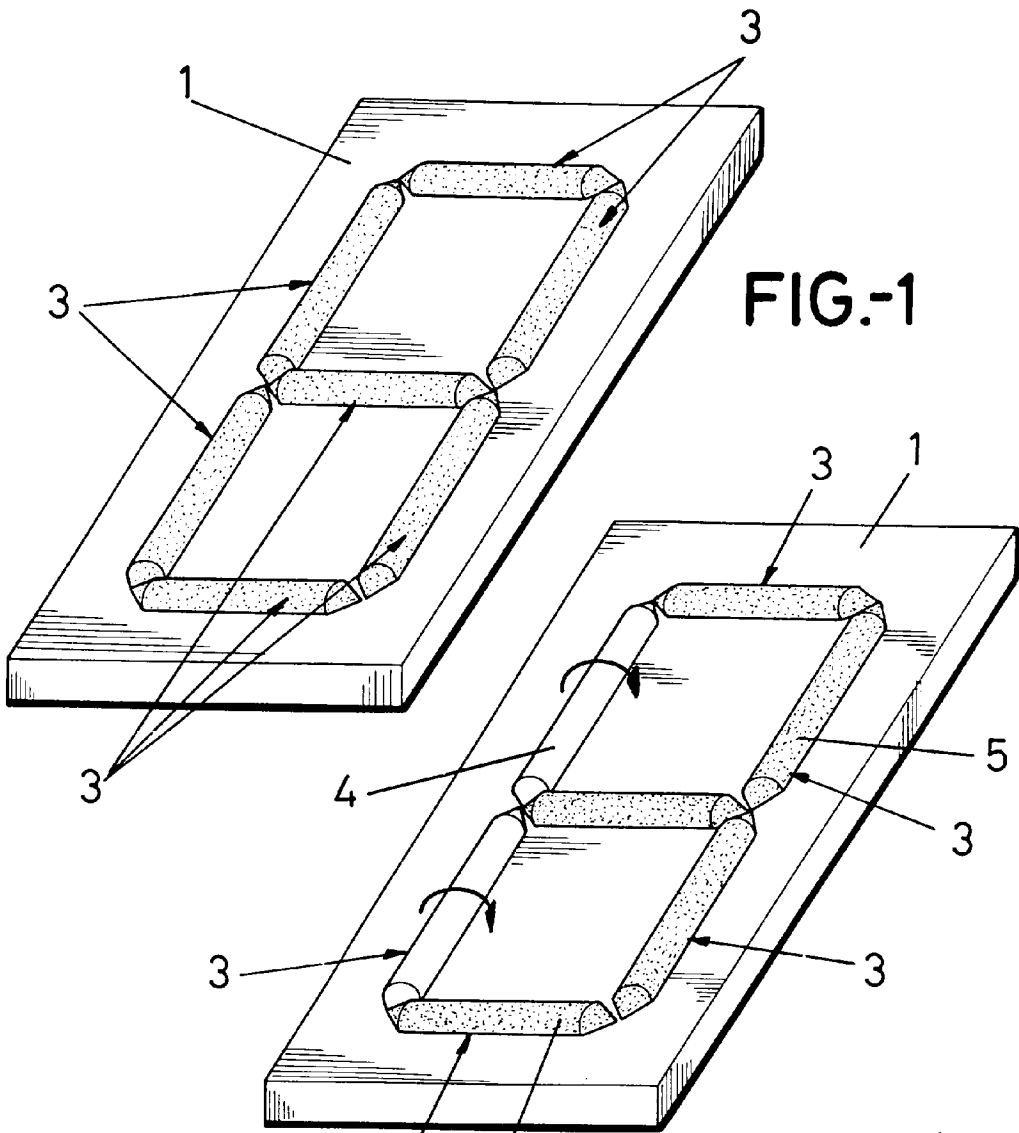
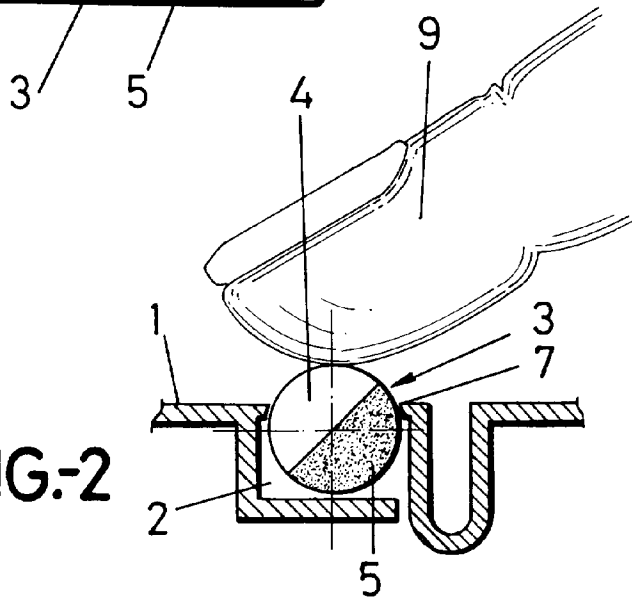

FIG-1A



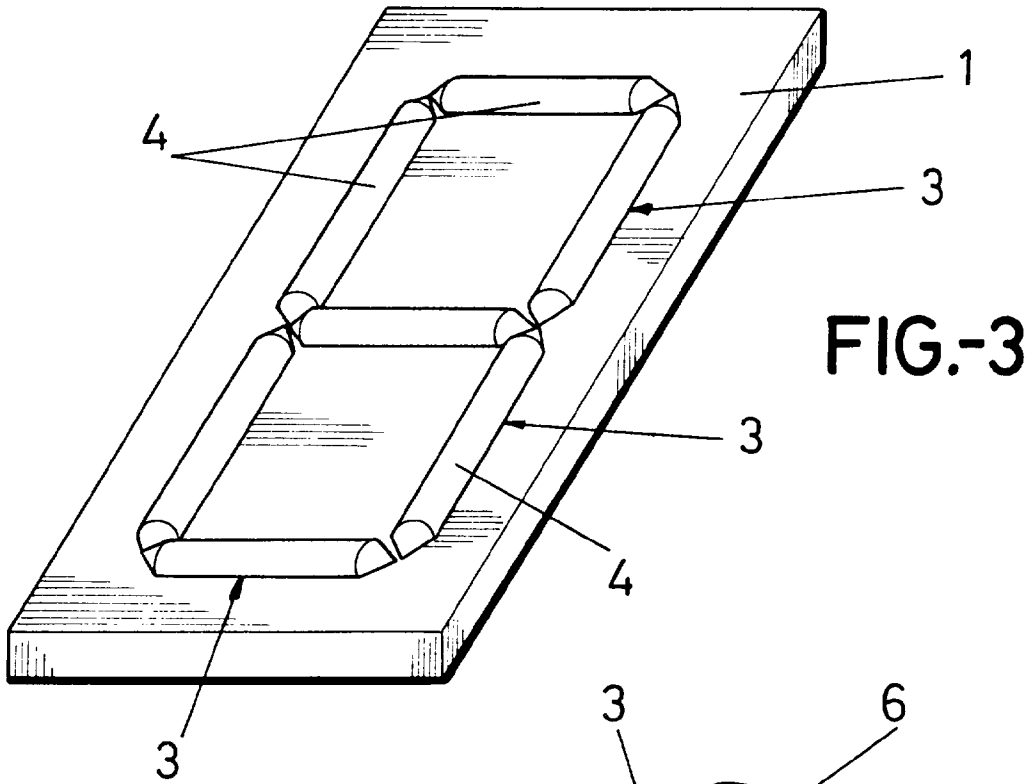

FIG.-3

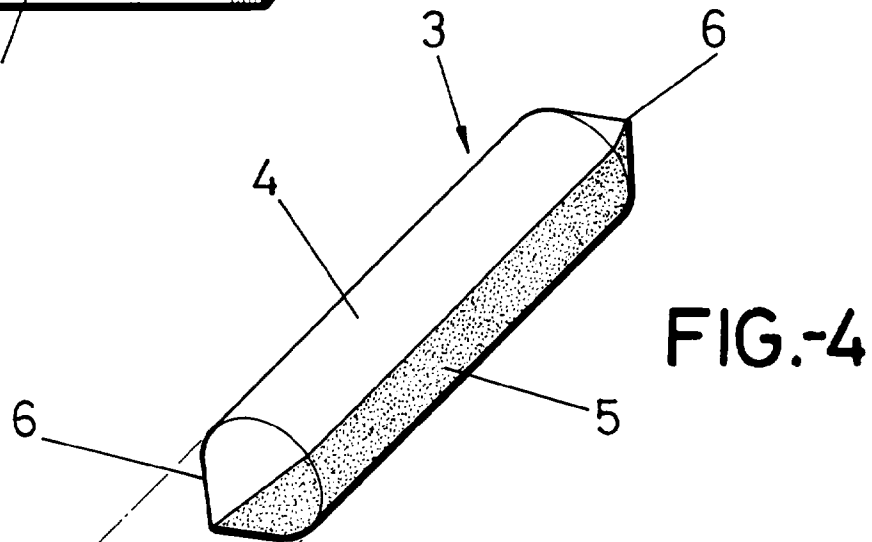

FIG.-4

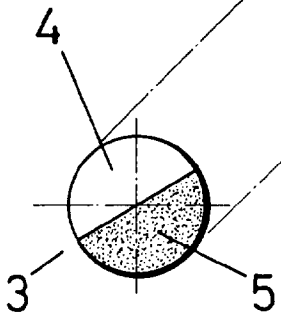

FIG.-1A

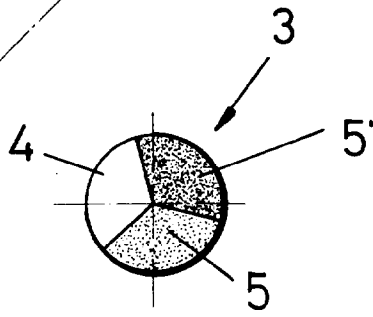

FIG.-4B

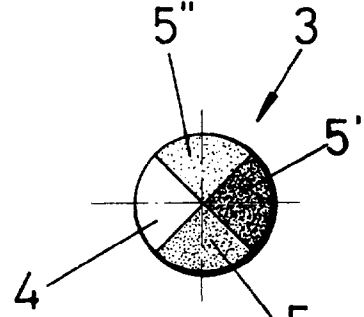

FIG.-4C

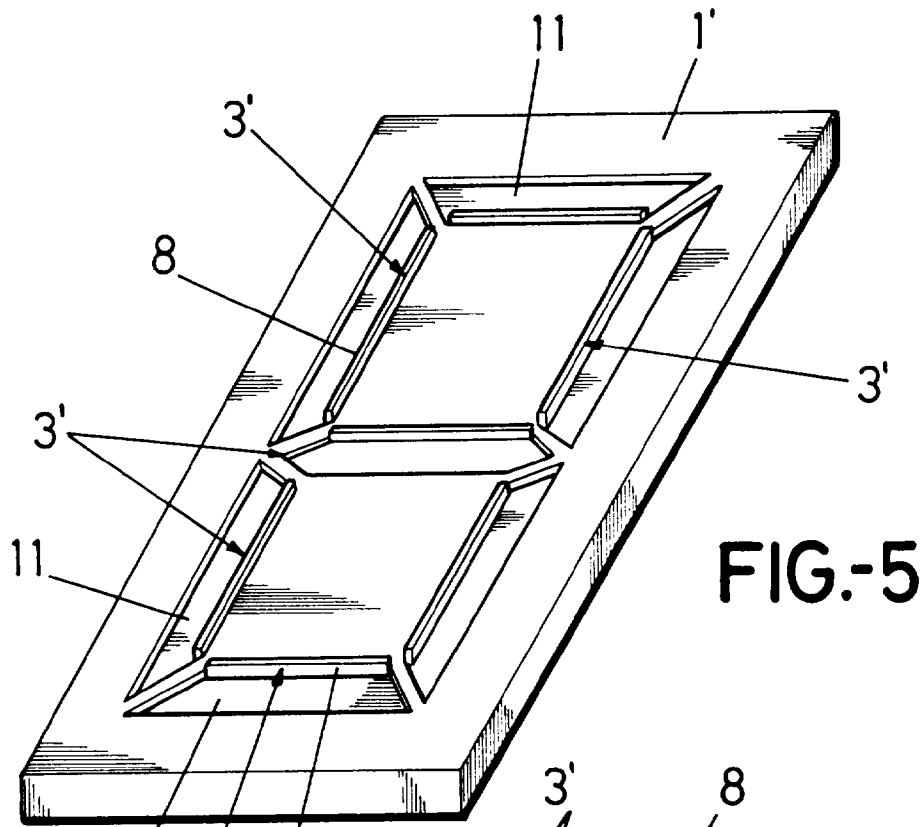

FIG-5

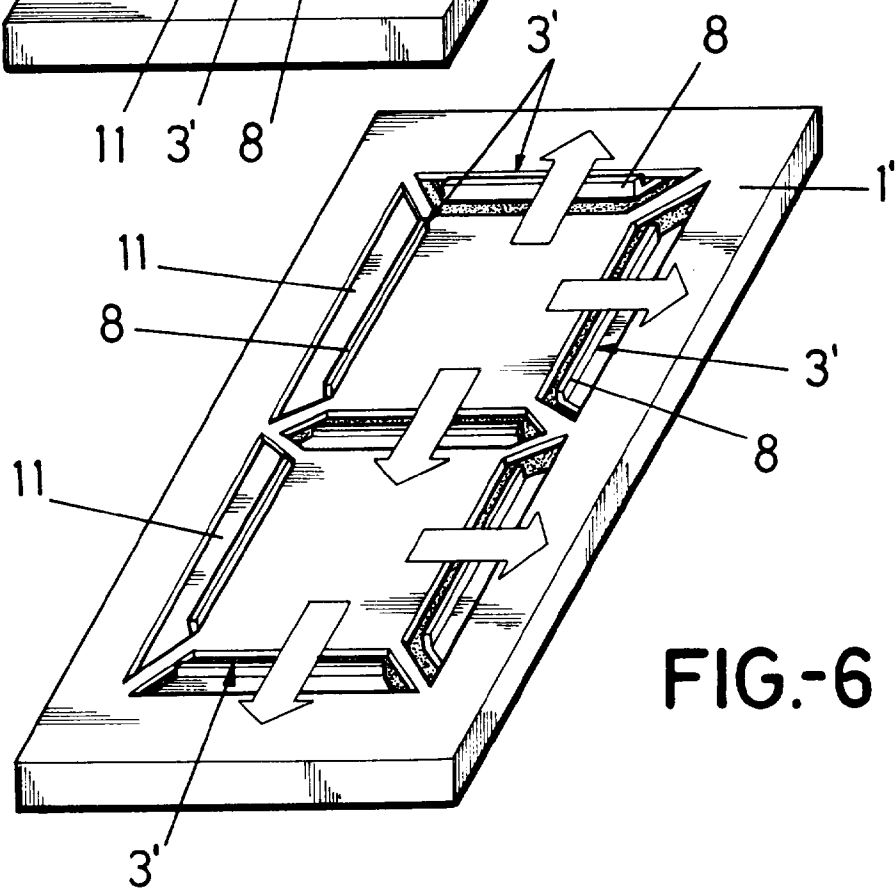
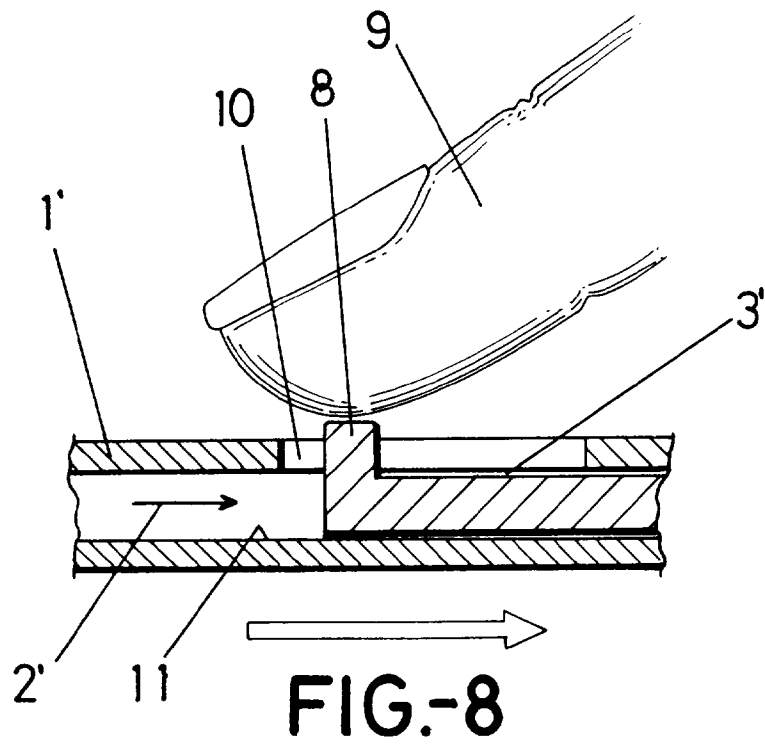
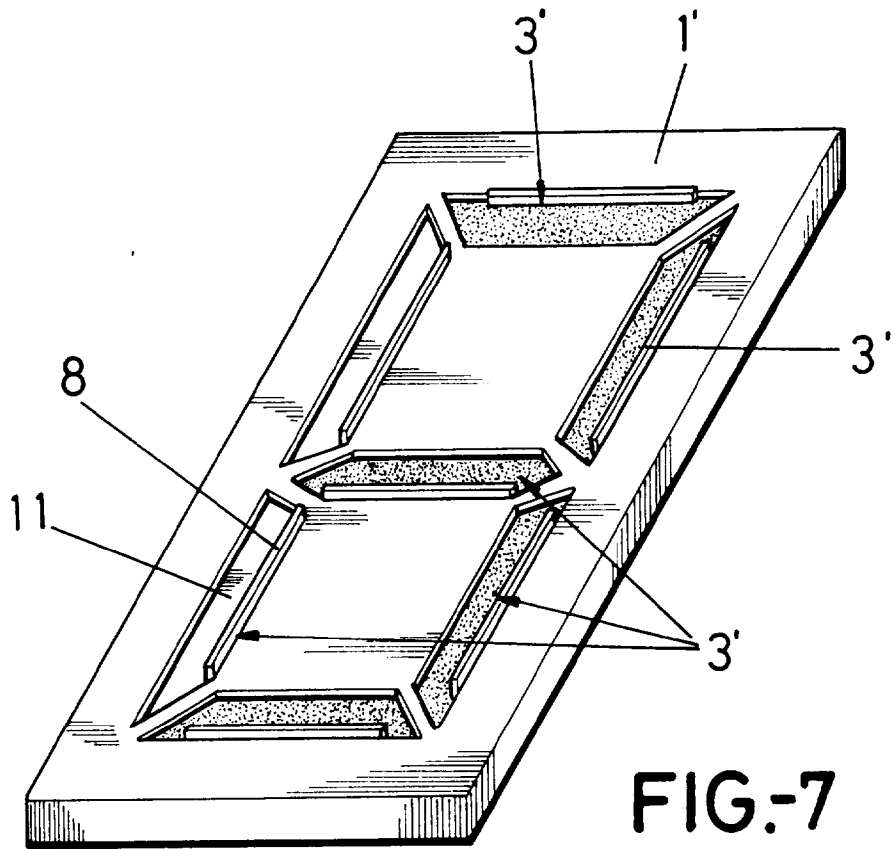

FIG-6





European Patent
Office

EUROPEAN SEARCH REPORT

Application Number
EP 96 50 0109

DOCUMENTS CONSIDERED TO BE RELEVANT			
Category	Citation of document with indication, where appropriate, of relevant passages	Relevant to claim	CLASSIFICATION OF THE APPLICATION (Int.Cl.6)
X	DE-A-31 43 412 (IDEEE DESIGN GMBH) * page 6, line 11 - page 7, line 14; figures 1-3 *	1,2,5, 7-15	G09F9/37
X	EP-A-0 031 033 (TAMBURINI) * page 4, line 1 - page 6, line 15; figures 1-8 *	1,2,5, 7-15	
X	GB-A-2 015 799 (BEATTIE) * page 1, line 36 - page 2, line 21; figures 1-4 *	1,3,4, 12-14	
X	EP-A-0 482 885 (KHOURY) * column 1, line 46 - column 2, line 46; figures 1-3 *	1,2,7,8, 12-15	
			TECHNICAL FIELDS SEARCHED (Int.Cl.6)
			G09F
The present search report has been drawn up for all claims			
Place of search BERLIN		Date of completion of the search 21 November 1996	Examiner Taylor, P
CATEGORY OF CITED DOCUMENTS		T : theory or principle underlying the invention E : earlier patent document, but published on, or after the filing date D : document cited in the application L : document cited for other reasons & : member of the same patent family, corresponding document	
X : particularly relevant if taken alone Y : particularly relevant if combined with another document of the same category A : technological background O : non-written disclosure P : intermediate document			

EPO FORM 1503 03.82 (P04CO1)