



(19) **United States**

(12) **Patent Application Publication**
Shapiro

(10) **Pub. No.: US 2004/0115323 A1**

(43) **Pub. Date: Jun. 17, 2004**

(54) **SYSTEM FOR PACKAGING, STORING & TRANSPORTING AGRICULTURAL PRODUCE**

(52) **U.S. Cl. 426/393**

(76) **Inventor: Ariel Shapiro, Herzliya (IL)**

(57) **ABSTRACT**

Correspondence Address:
Ladas & Parry
26 West 61st Street
New York, NY 10023 (US)

A system and method for packing agricultural produce including functionality for: providing a container having at least one communications aperture formed in a wall thereof; providing at least one flexible controlled permeability bag within the container; providing at least one bag aperture in the at least one flexible controlled permeability bag in general registration with the at least one communications aperture; sealing the produce inside the at least one flexible controlled permeability bag within the container, while leaving the at least one bag aperture and the at least one communications aperture open; providing atmosphere treatment within the at least one bag via the at least one bag aperture and the at least one communications aperture; and sealing at least one of the at least one bag aperture and the at least one communications aperture.

(21) **Appl. No.: 10/466,704**

(22) **PCT Filed: Jan. 17, 2002**

(86) **PCT No.: PCT/IL02/00048**

(30) **Foreign Application Priority Data**

Jan. 19, 2001 (US)..... 09765794

Publication Classification

(51) **Int. Cl.⁷ A23B 4/00**

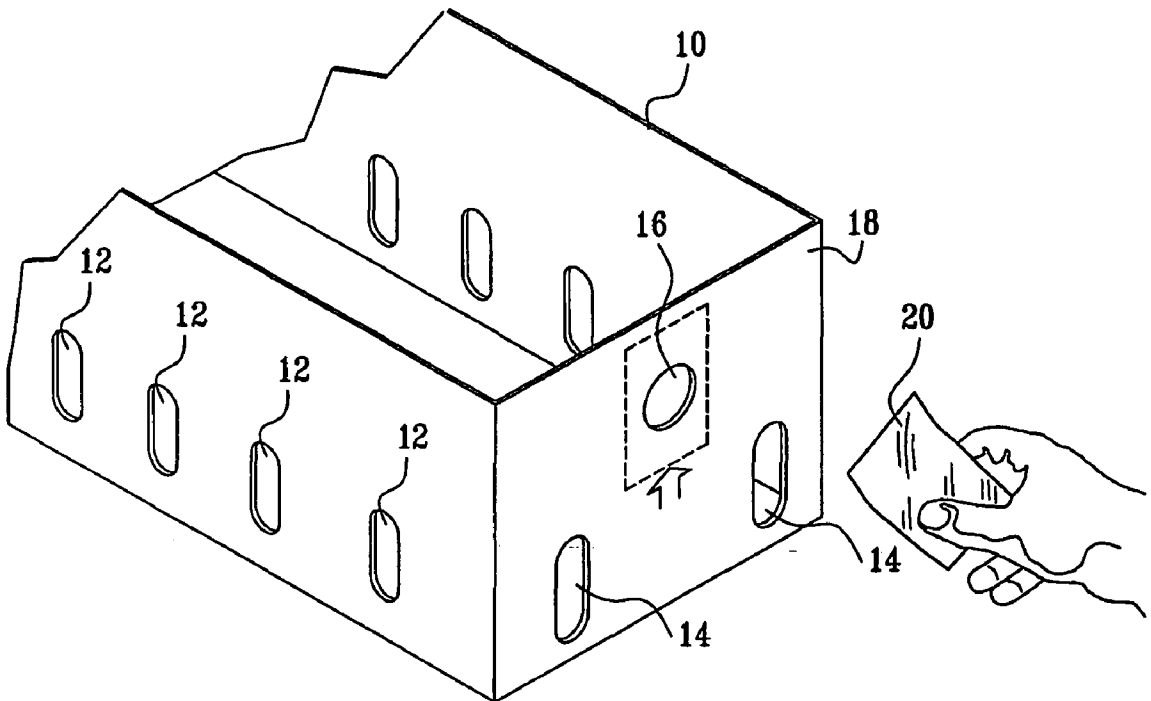

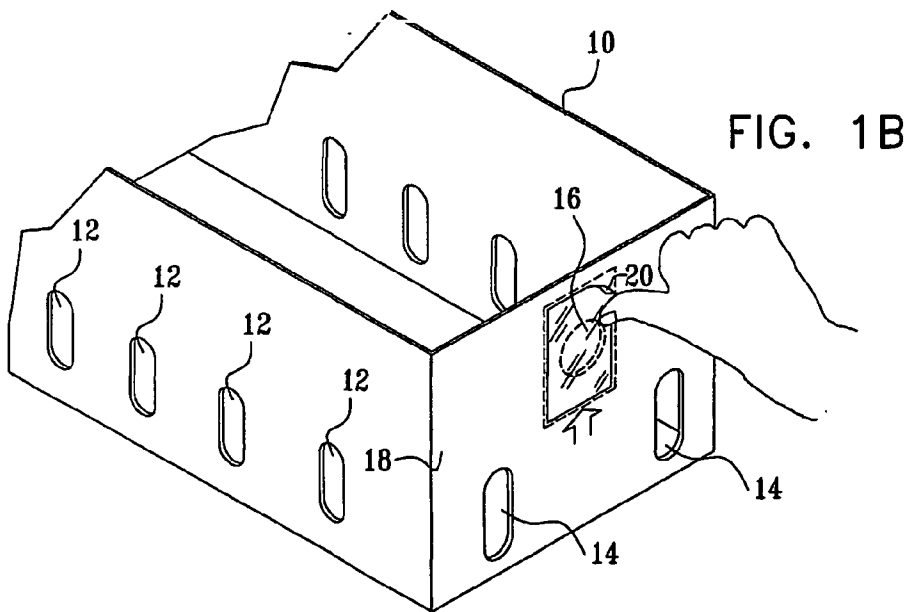
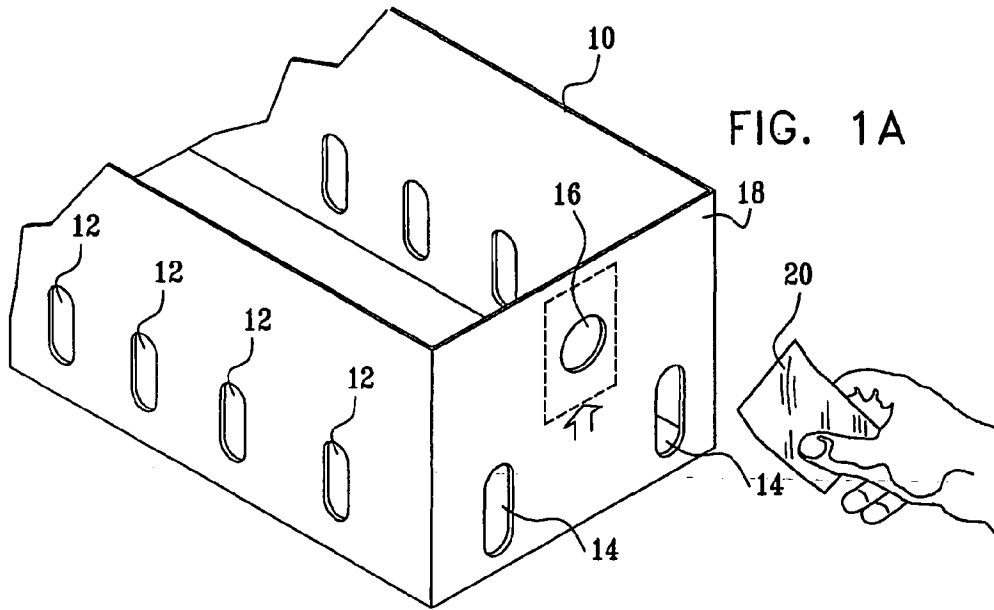

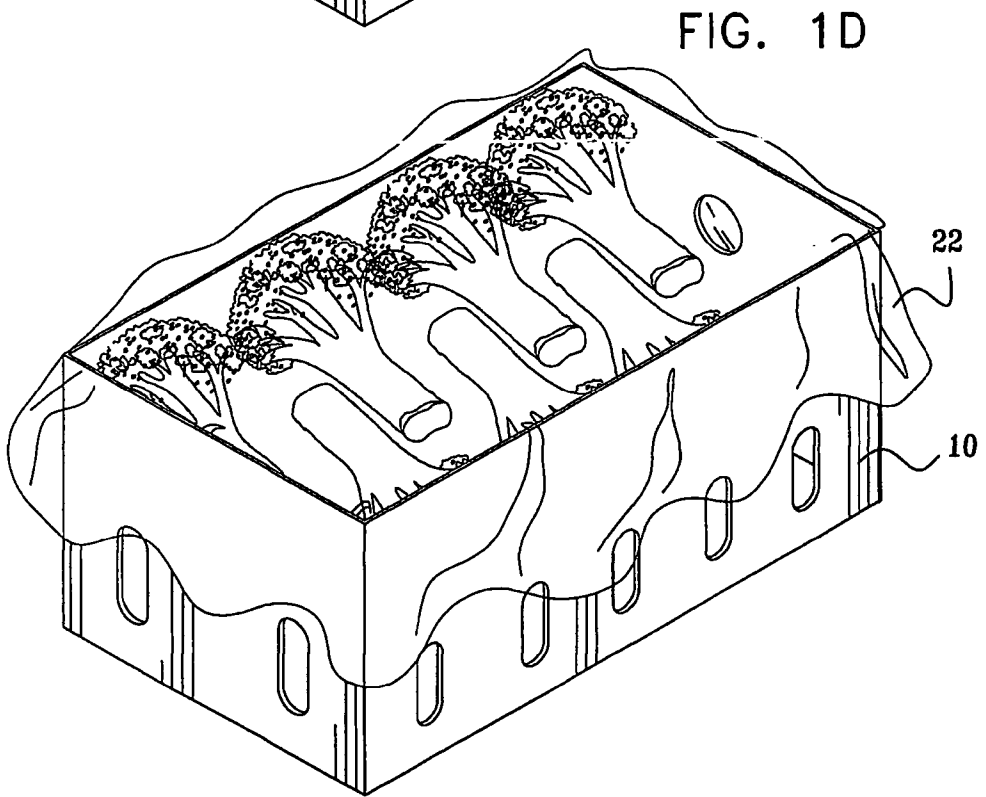
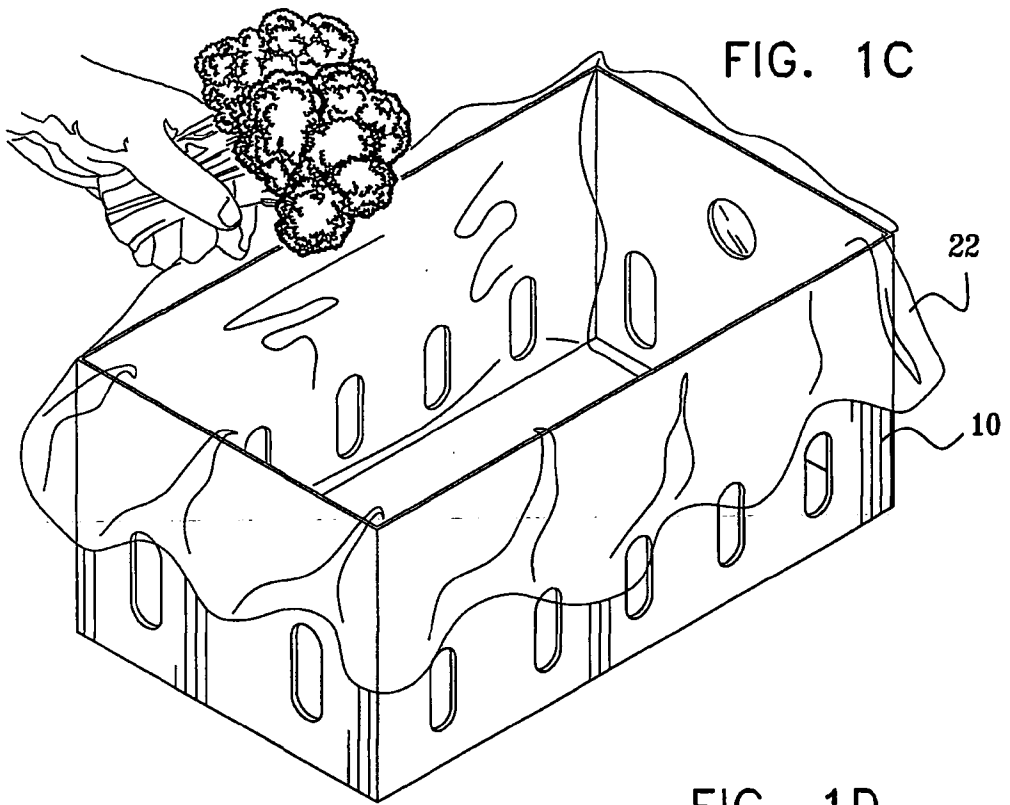

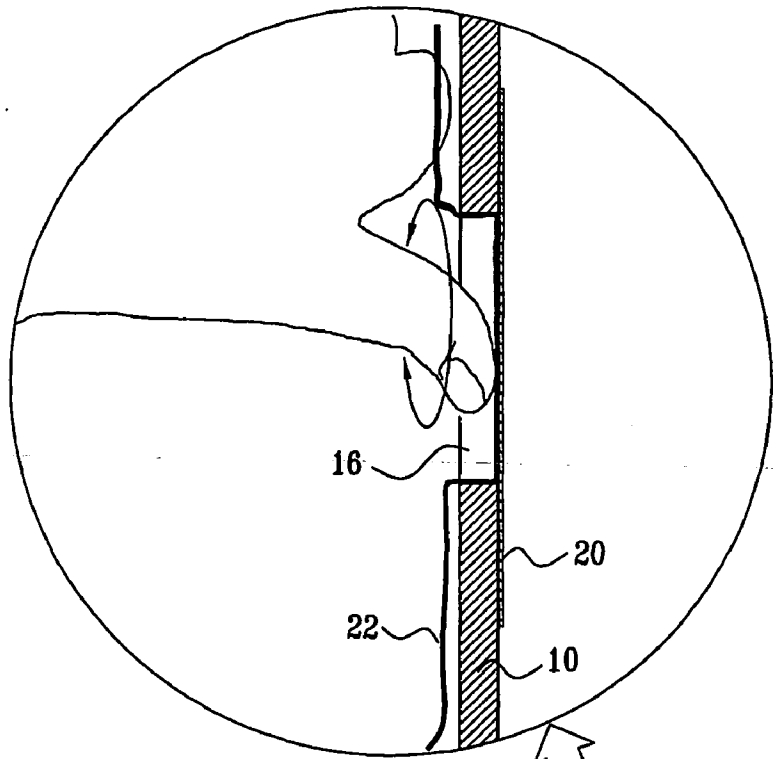
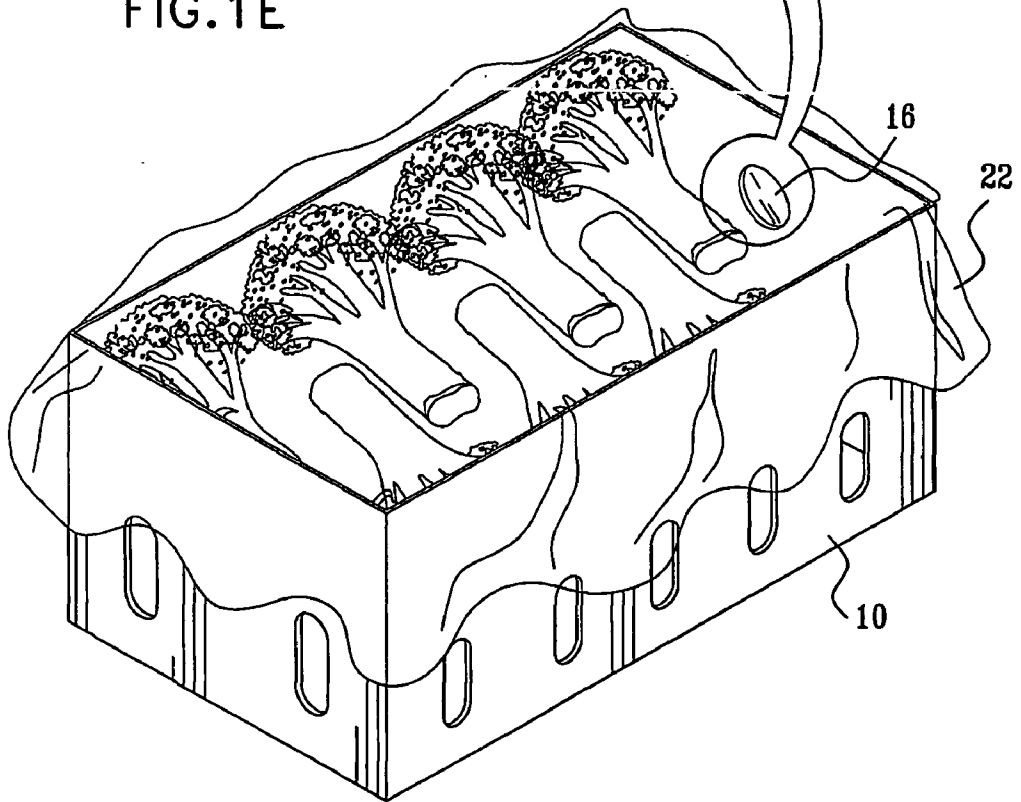
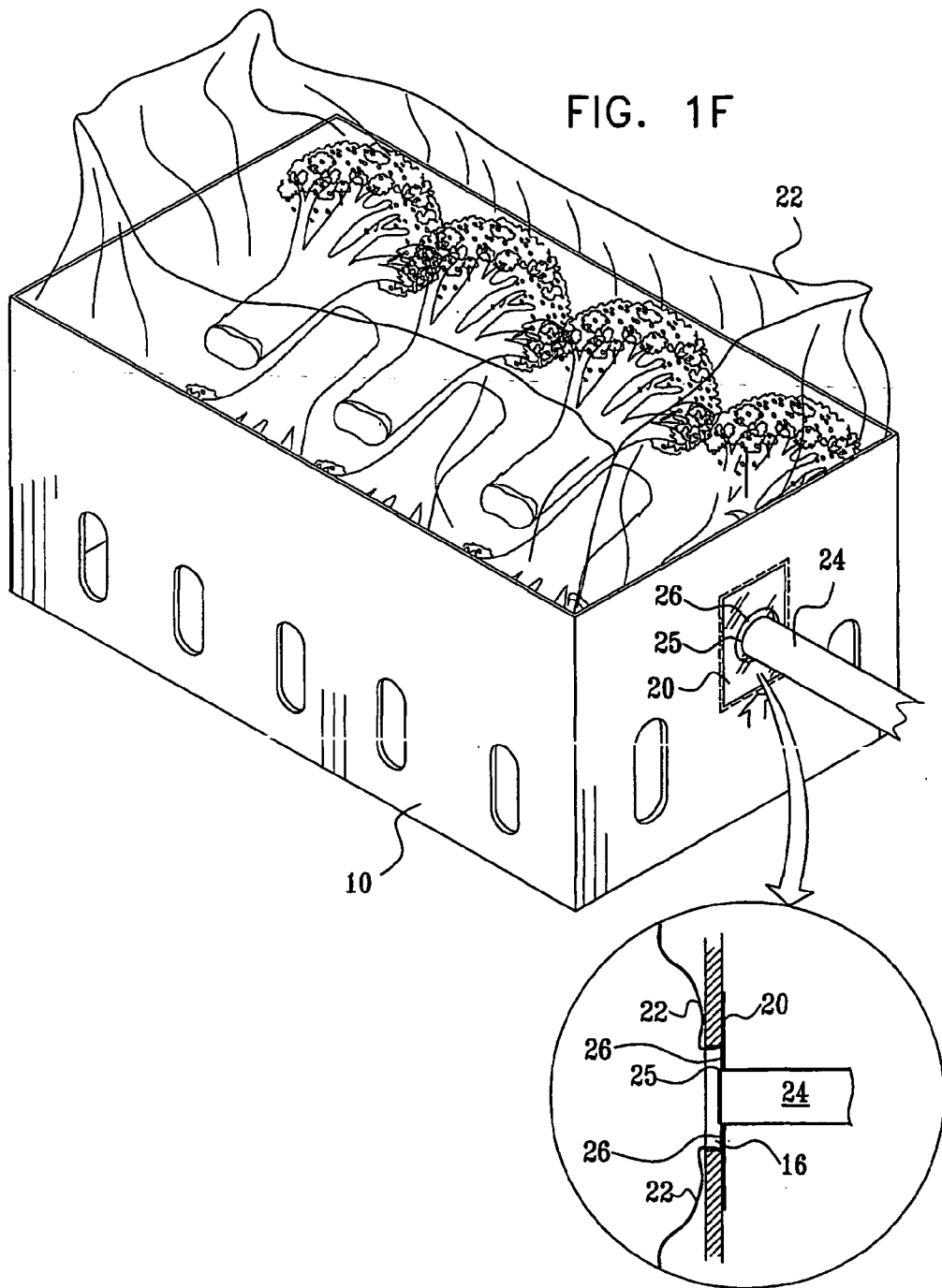

FIG. 1E





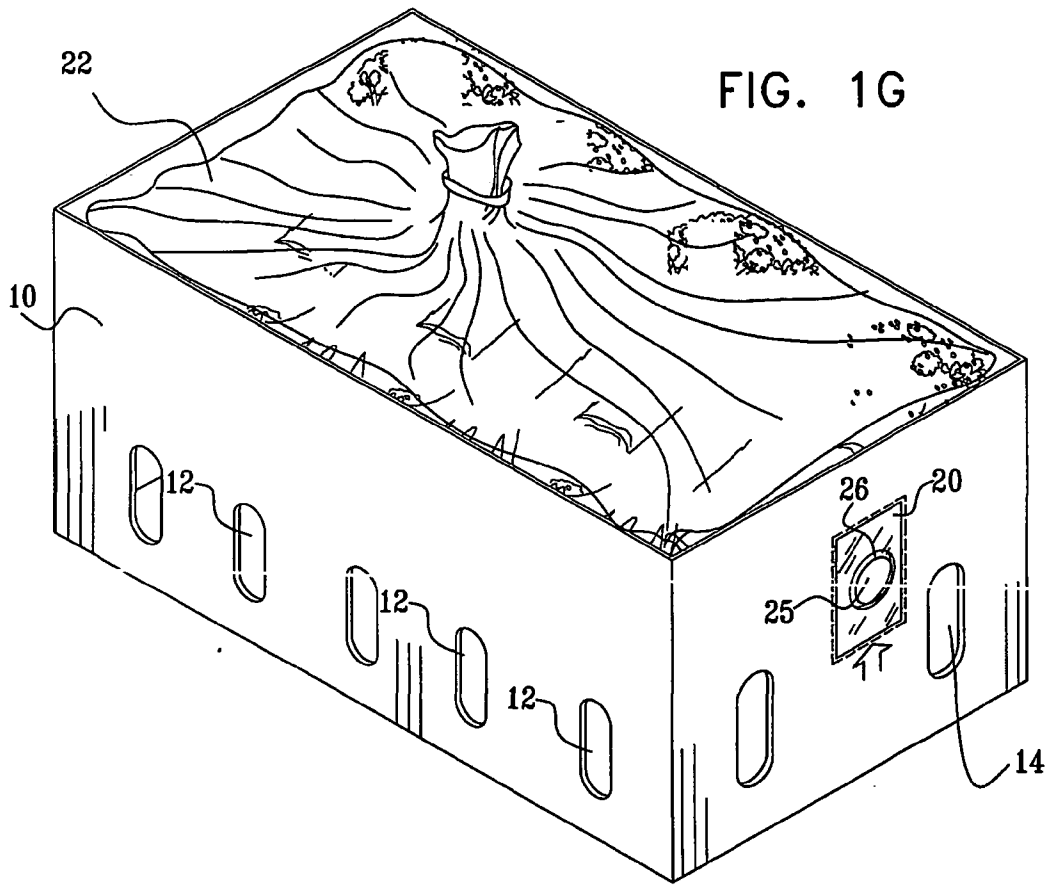

FIG. 2A

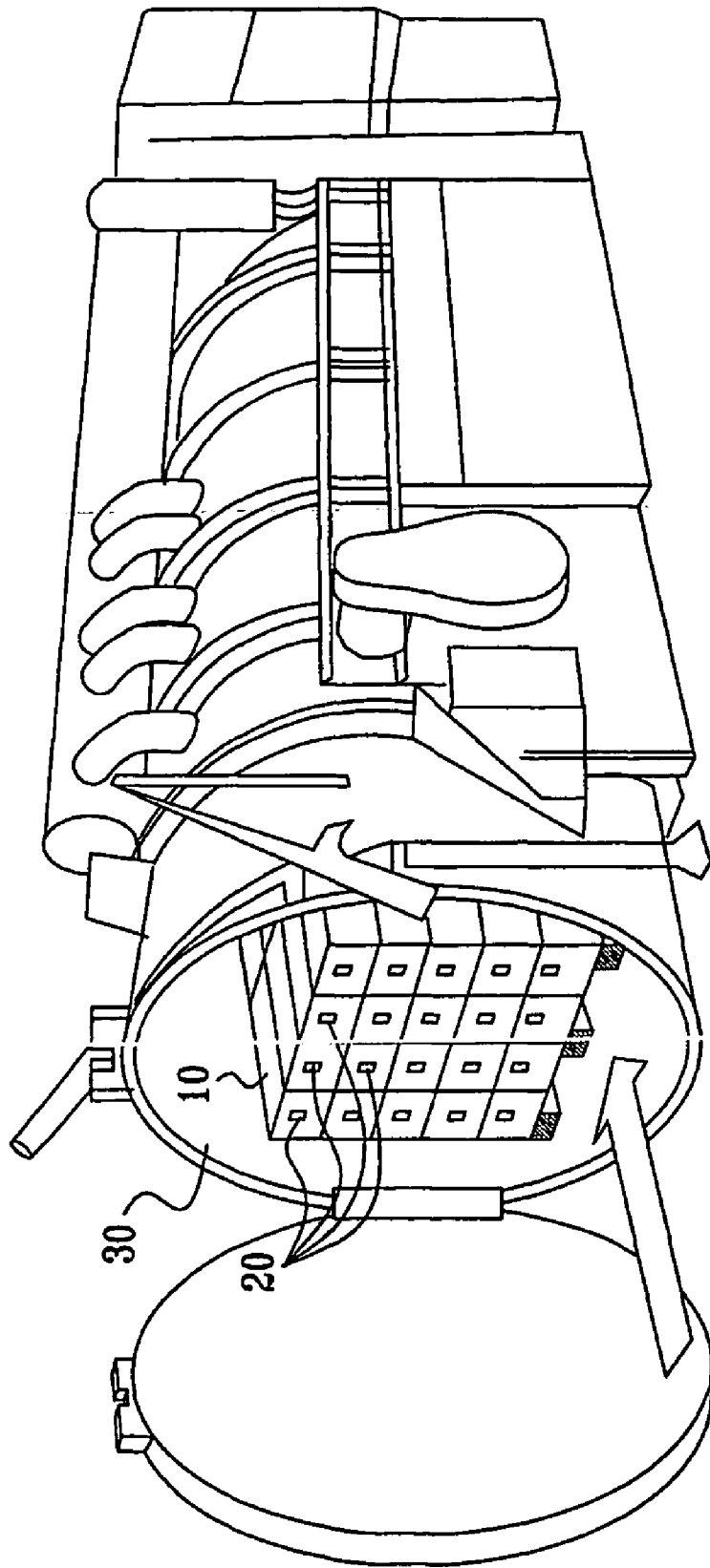
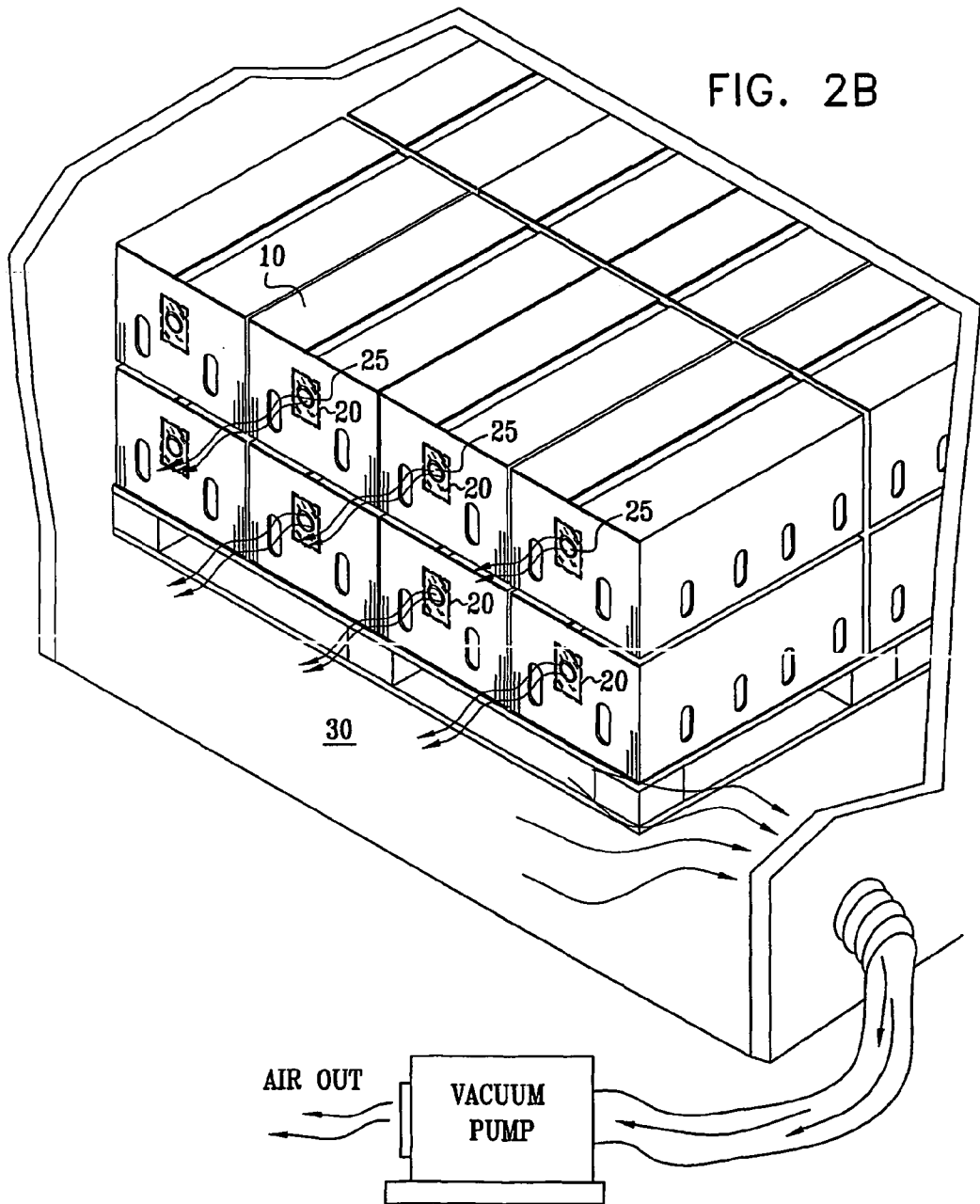
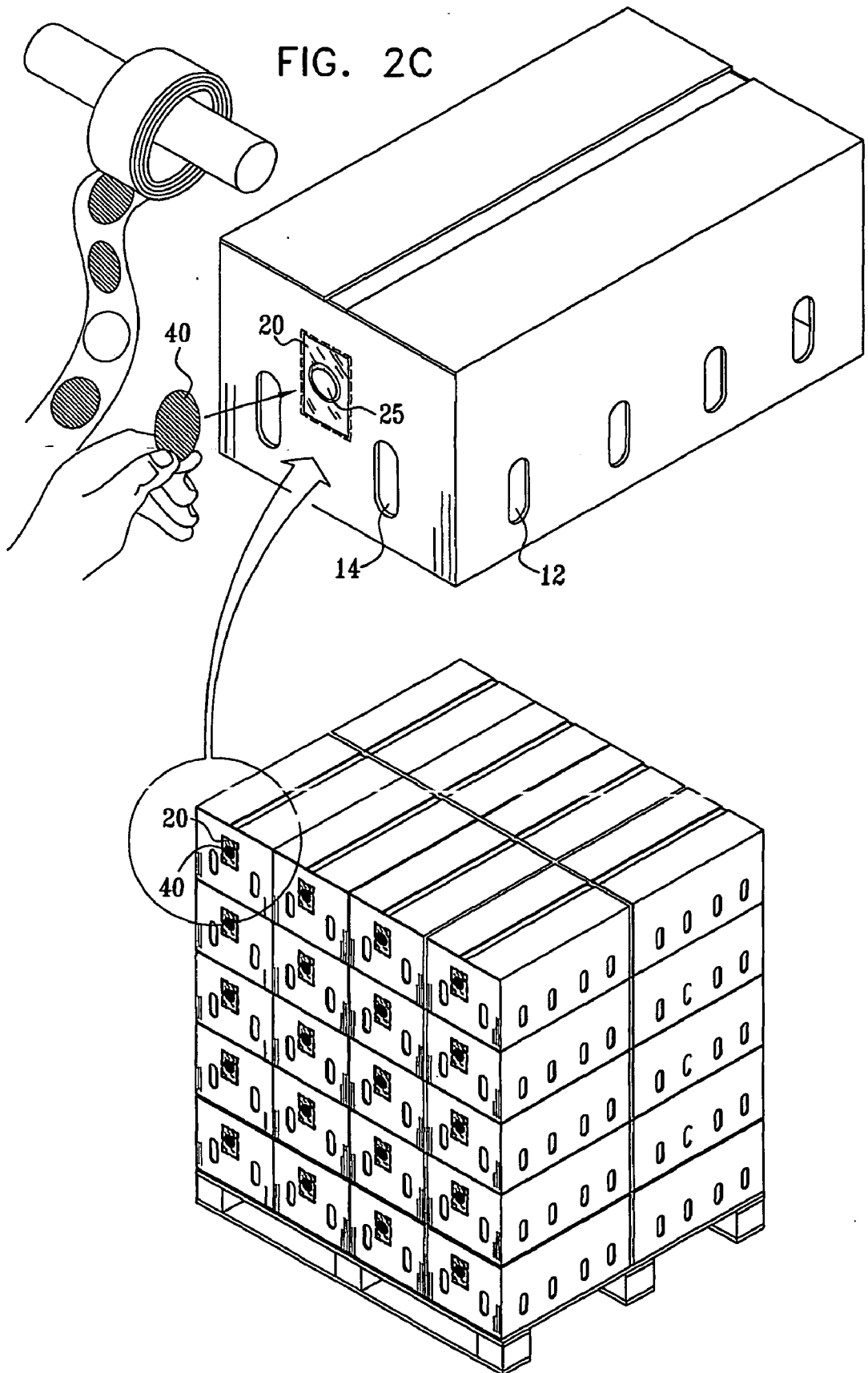

FIG. 2B





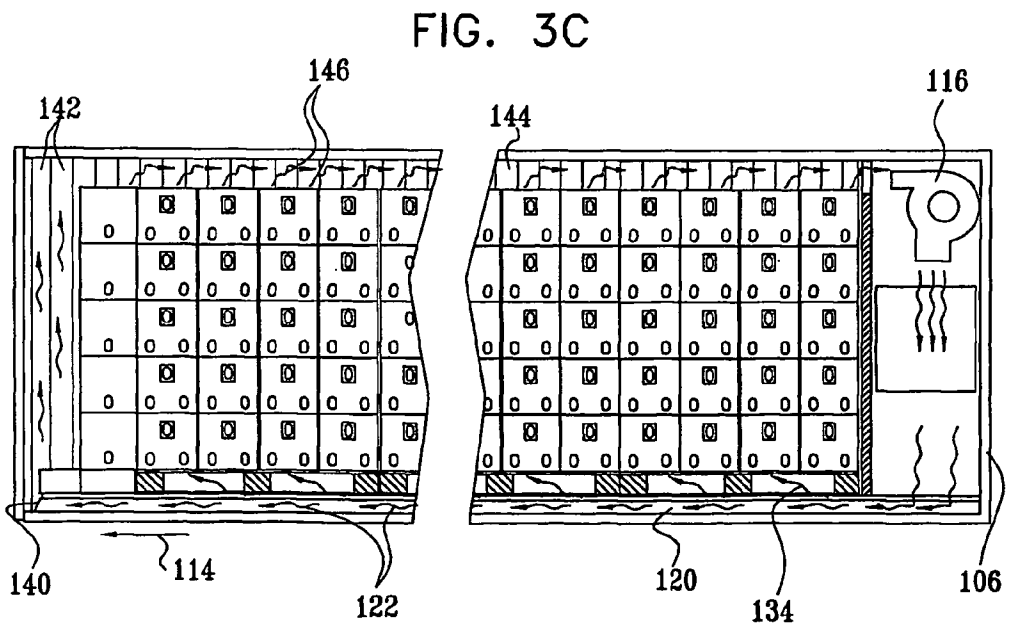
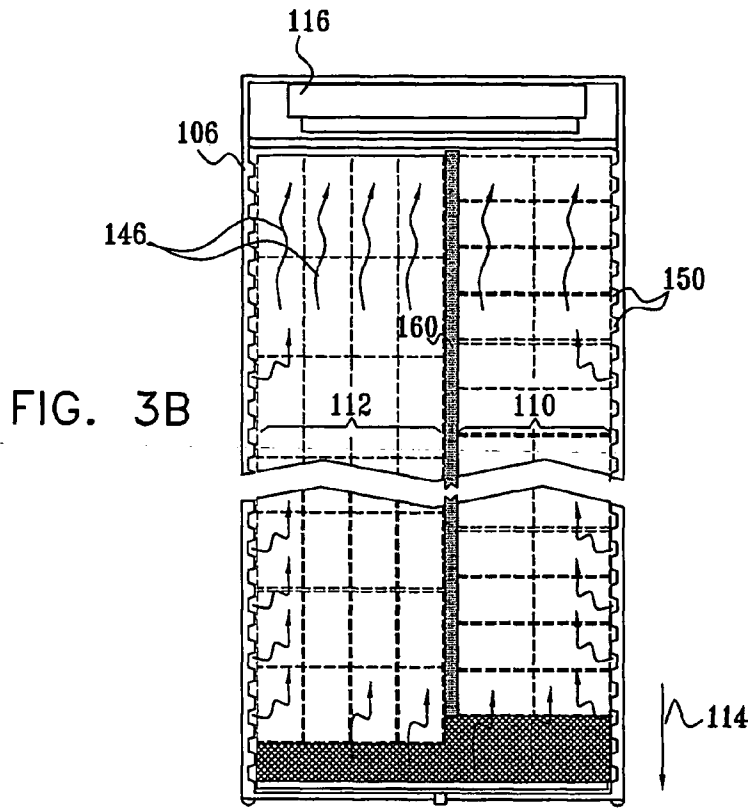
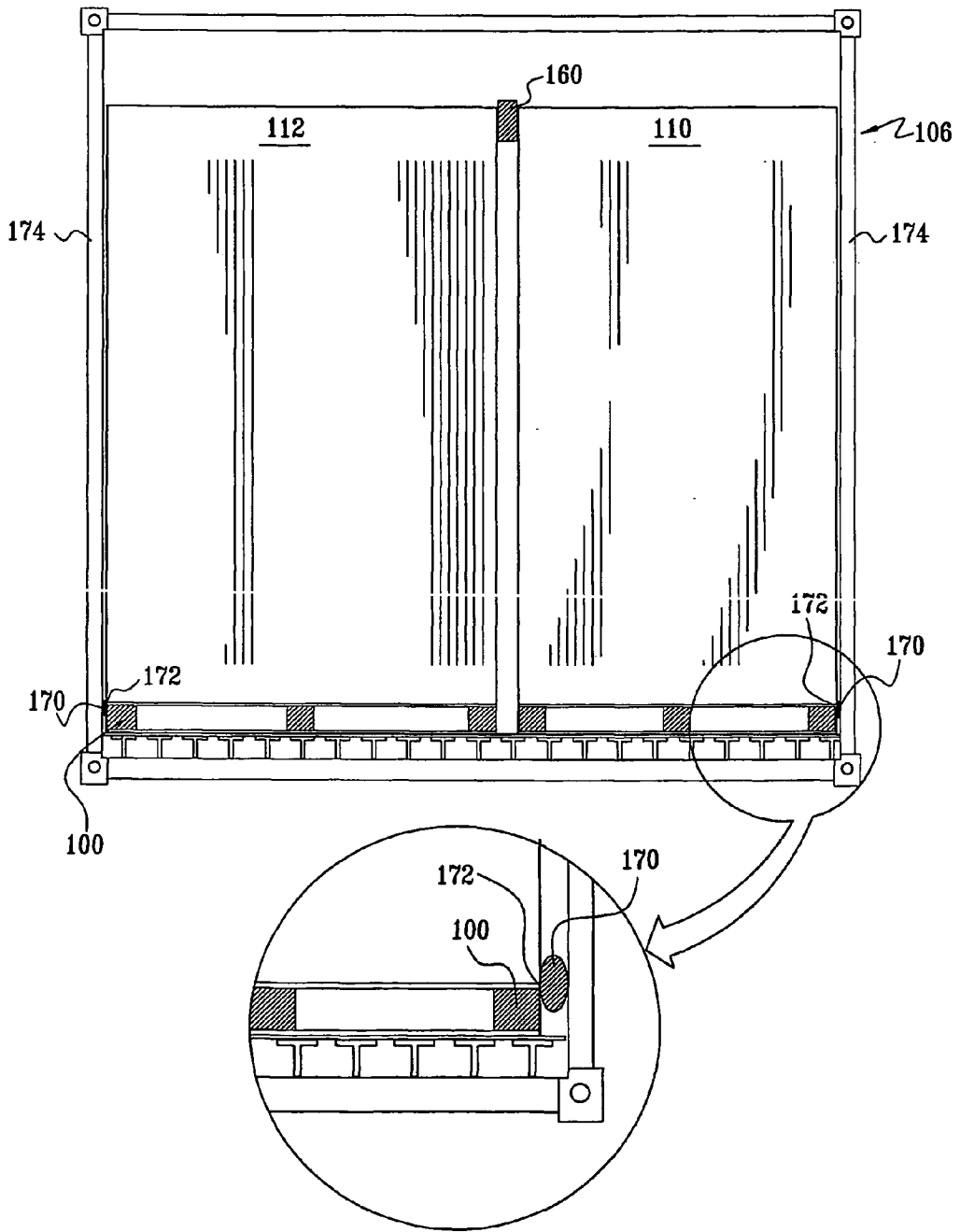
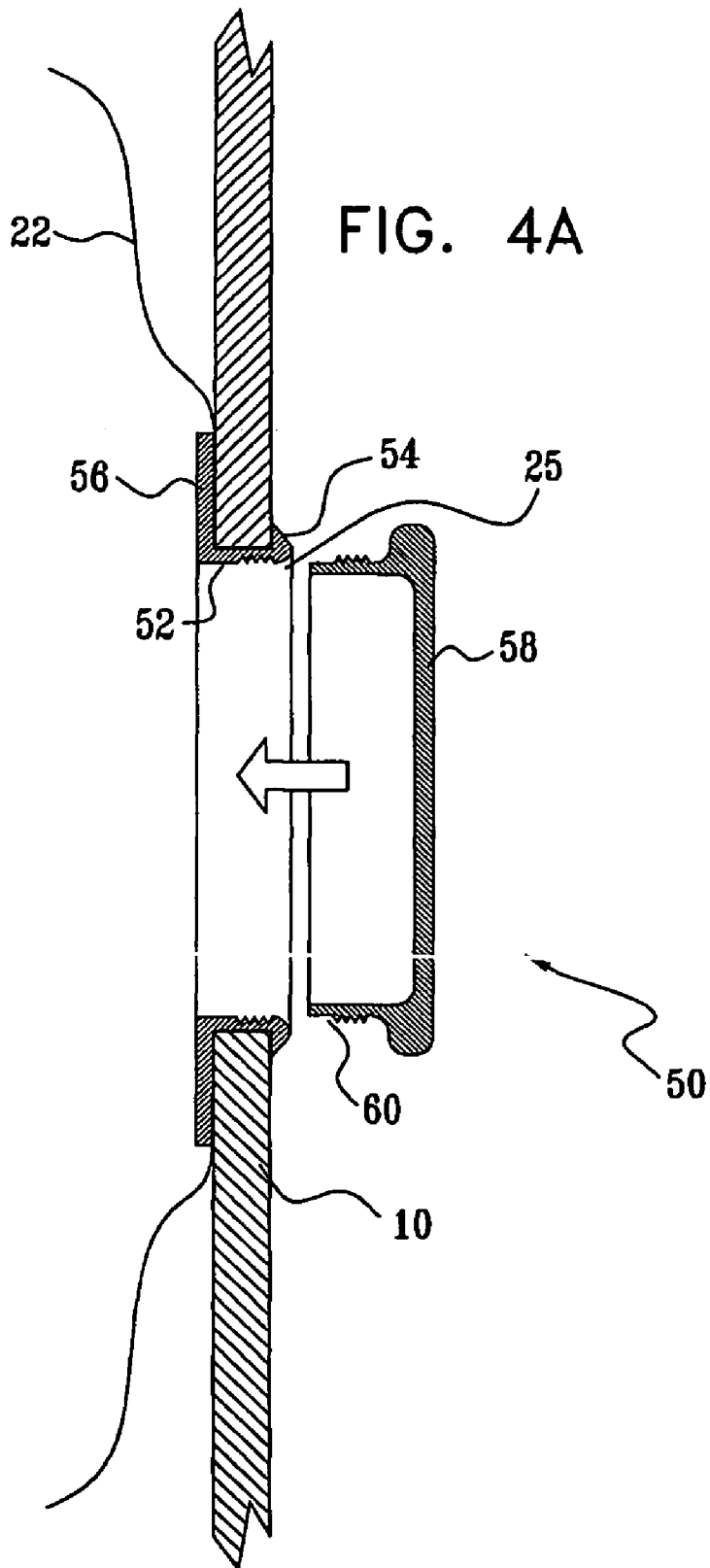
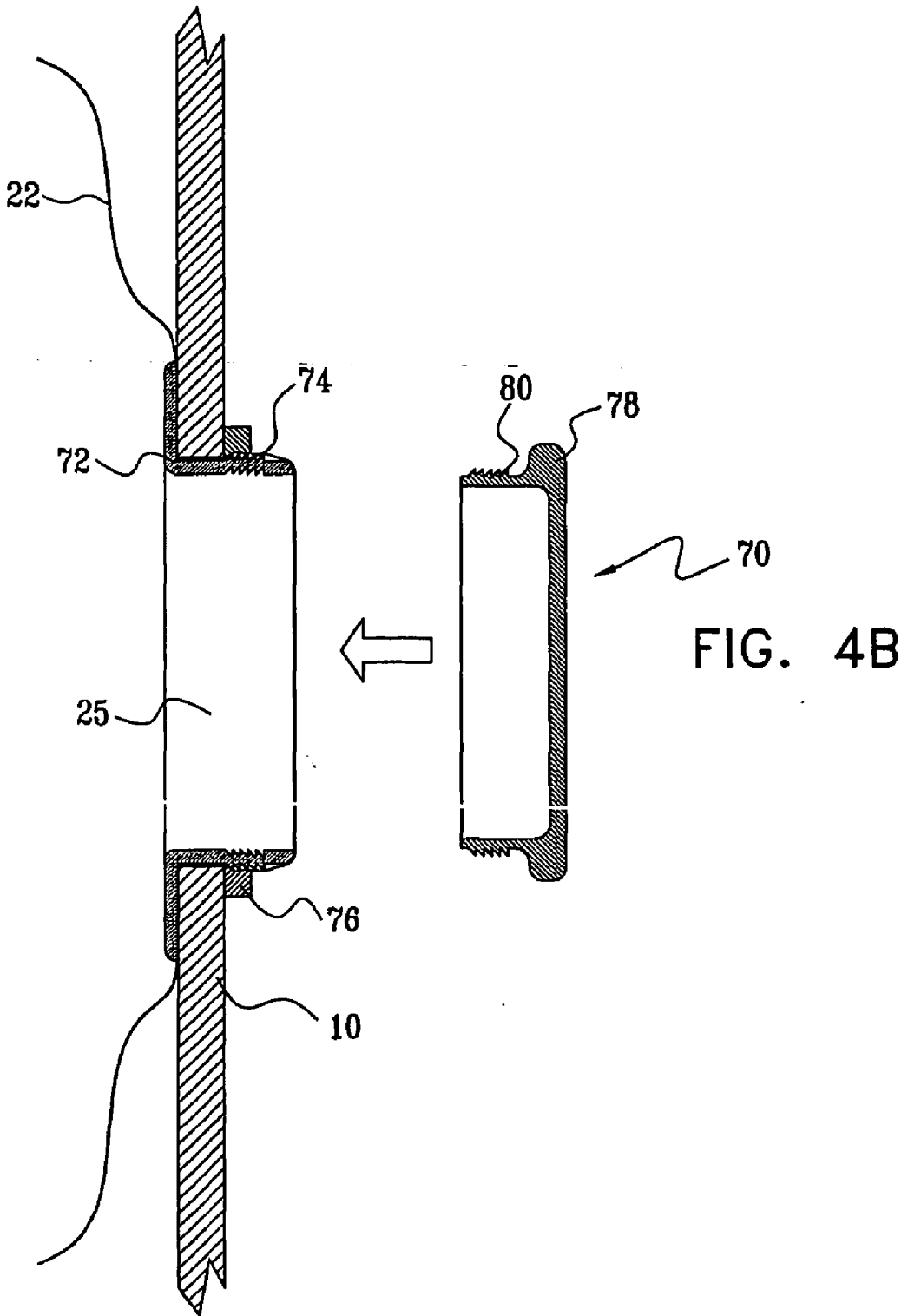

FIG. 3D







SYSTEM FOR PACKAGING, STORING & TRANSPORTING AGRICULTURAL PRODUCE

REFERENCE TO CO-PENDING APPLICATION

[0001] Applicants hereby claim priority of U.S. patent application Ser. No. 09/765,794, filed Jan. 19, 2001, entitled "A System For Packaging, Storing and Transporting Agricultural Produce".

FIELD OF THE INVENTION

[0002] The present invention relates to methodologies and systems for packaging, storing and transporting agricultural produce generally.

BACKGROUND OF THE INVENTION

[0003] There are known various techniques and systems for packaging, storing and transporting agricultural produce. The following US patents are believed to represent the state of the art: U.S. Pat. Nos. 5,421,138; 4,535,586; 4,981,007; 4,899,517. The known conventional techniques have significant limitations and disadvantages.

SUMMARY OF THE INVENTION

[0004] The present invention seeks to provide improved methodologies and systems for packaging, storing and transporting agricultural produce, which result in significant efficiencies and cost savings, without sacrificing product quality.

[0005] In the present specification and claims, the following terms are used: "bag" which relates to a container for agricultural produce in which a "Modified Atmosphere" condition is established by controlling the amounts and relationships of the appropriate gas components, which are required for extending the storage and shelf life of the agricultural product, for example agricultural produce, flowers and bulbs. "vapor" relates to liquids in the form of a gas or a gas with free floating water droplets, as for example, in condensation.

[0006] "carton" relates to containers or boxes constructed from materials such as plastic, wood or metal, for storing agricultural products.

[0007] "adhesive" relates to a sealing element for a venting closure system, by using such devices as a latch, cap-locking system or an adhesive sticker.

[0008] There is thus provided in accordance with a preferred embodiment of the present invention a method for packing agricultural produce including the steps of:

[0009] providing a container having at least one communications aperture formed in a wall thereof;

[0010] providing at least one flexible controlled permeability bag within the container;

[0011] providing at least one bag aperture in the at least one flexible controlled permeability bag in general registration with the at least one communications aperture;

[0012] sealing the produce inside the at least one flexible controlled permeability bag within the container, while leaving the at least one bag aperture and the at least one communications aperture open;

[0013] providing atmosphere treatment within the at least one bag via the at least one bag aperture and the at least one communications aperture; and

[0014] sealing at least one of the at least one bag aperture and the at least one communications aperture.

[0015] There is also provided in accordance with a preferred embodiment of the present invention, a system for packing agricultural produce including:

[0016] at least one container having at least one communications aperture formed in a wall thereof;

[0017] at least one flexible controlled permeability bag within the container, the at least one bag having an aperture in general registration with the at least one communications aperture and being adapted for containing the produce inside the at least one flexible controlled permeability bag within the container, while leaving the at least one bag aperture and the at least one communications aperture open;

[0018] treatment functionality, operative for providing atmosphere treatment within the at least one bag via the at least one bag aperture and the at least one communications aperture; and

[0019] sealing functionality for sealing at least one of the at least one bag aperture and the at least one communications aperture.

[0020] According to a preferred embodiment of the present invention, the atmosphere treatment includes vacuum cooling.

[0021] Additionally or alternatively, the atmosphere treatment includes at least one of fumigation or other gas treatment, such as ripening treatment.

[0022] Preferably, the at least one communications aperture formed in a wall thereof is formed in a sealing layer adhered to a wall of the carton.

[0023] In accordance with a preferred embodiment of the present invention, the flexible controlled vapor and gas selective permeability bag includes a gas impermeable bag, preferably a gas permeable bag having selected permeability characteristics adapted to a given type of produce.

[0024] Preferably, the methodology of providing at least one bag aperture in the flexible controlled permeability bag in general registration with the at least one communications aperture includes:

[0025] inserting the bag into the container;

[0026] at least partially filling the bag with the produce;

[0027] adhering the bag to the container adjacent the at least one communications aperture; and

[0028] aperturing the bag generally in registration with the at least one communications aperture.

[0029] Where the at least one communications aperture formed in a wall thereof is formed in a sealing layer adhered to a wall of the carton, the functionality of providing at least

one bag aperture in the flexible controlled permeability bag in general registration with the at least one communications aperture includes:

- [0030] inserting the bag into the container;
- [0031] at least partially filling the bag with the produce;
- [0032] adhering the bag to the container adjacent the at least one communications aperture; and
- [0033] aperturing the bag and the sealing layer in a single operation.

[0034] Preferably, the sealing at least one of the at least one bag aperture and the at least one communications aperture includes attaching an adhesive sticker or a cap over the at least one communications aperture from the outside of the container.

[0035] There is also provided in accordance with a preferred embodiment of the present invention a box suitable for packing agricultural produce and including at least one sealable localized atmosphere communication aperture formed in a wall thereof.

[0036] Preferably, the carton also includes a plurality of ventilation apertures formed in at least one wall thereof.

[0037] In accordance with a preferred embodiment of the present invention, the carton also includes a gas impervious layer arranged for sealing engagement with the at least one sealable localized atmosphere communication aperture.

[0038] Preferably, the box includes an interiorly disposed bag, which is preferably a modified atmosphere bag.

[0039] Preferably, the sealing layer is an adhesive-coated plastic sticker and the bag is adhered to the adhesive-coated plastic sticker. In accordance with a preferred embodiment of the present invention, the bag and the adhesive-coated plastic sticker are both apertured adjacent the sealable localized atmosphere communication aperture, thereby to provide a fluid communication pathway between the interior of the bag and the exterior of the carton. A further gas impervious sealing layer may be employed for subsequently sealingly engaging the adhesive-coated plastic sticker, thereby sealing the interior of the bag from the exterior of the carton.

[0040] Additionally in accordance with a preferred embodiment of the present invention, there is provided a method for loading a refrigerated container having a refrigeration unit producing a flow of forced air and a flow of return air under negative pressure in order to provide maximum loading and cooling efficiency, the method including:

- [0041] loading palletized ventilated cartons having ventilating apertures formed in walls thereof into a refrigerated shipping container in a manner such that there is defined a central plenum between rows of loaded pallets; and
- [0042] selectively blocking air passages inside the container such that the forced air flow is directed principally through the plenum and through interstices between ones of the ventilated containers and thus generally horizontally through the ventilating apertures.

[0043] There is additionally provided in accordance with a preferred embodiment of the present invention, a loaded refrigerated container having a refrigeration unit producing

a flow of forced air and a flow of return air under negative pressure in order to provide maximum loading and cooling efficiency, the loaded container also including:

- [0044] palletized ventilated cartons having ventilating apertures formed in walls thereof positioned in the refrigerated shipping container in a manner such that there is defined a central plenum between rows of loaded pallets and wherein
- [0045] air passages inside the container are selectively blocked, such that the forced air flow is directed principally through the plenum, through interstices between ones of the ventilated containers and thus generally horizontally through the ventilating apertures.

[0046] In accordance with a preferred embodiment of the present invention, a forced air flow from the refrigeration unit is supplied along channels formed in a floor of the container and extending parallel to a longitudinal axis thereof; at least a portion of the forced air output rises through spaces between adjacent floor elements in the floor of the shipping container, except where physically blocked and relatively unimpeded from a channel underlying the plenum; and at least a portion of the forced air output rises relatively unimpeded from open ends of the channels at a back end of the container into back plenum defined rearwardly of the rows of pallets

BRIEF DESCRIPTION OF THE DRAWINGS

[0047] The present invention will be understood and appreciated more fully from the following detailed description, taken in conjunction with the drawings in which:

[0048] FIGS. 1A-1G are simplified pictorial illustrations of seven initial stages in packaging produce in accordance with a preferred embodiment of the present invention;

[0049] FIGS. 2A-2C are simplified pictorial illustrations of three stages in treating produce packaged in accordance with the embodiment of FIGS. 1A-1G;

[0050] FIGS. 3A-3C are simplified pictorial illustrations of a methodology for loading a refrigerated container to provide maximum loading and cooling efficiency;

[0051] FIG. 3D is a simplified cross-sectional view, taken along lines IIID-IIID in FIG. 3A, showing the location of a blocking element, in accordance with another preferred embodiment of the invention.

[0052] FIG. 4A is a simplified illustration of a sealing element for packaging produce, in accordance with a preferred embodiment of the present invention; and

[0053] FIG. 4B is a simplified illustration of another type of sealing element for packaging produce, in accordance with another preferred embodiment of the invention;

DETAILED DESCRIPTION OF PREFERRED EMBODIMENTS

[0054] Reference is made to FIGS. 1A-1G, which are simplified pictorial illustrations of seven initial stages in packaging produce in accordance with a preferred embodiment of the present invention.

[0055] As seen in FIG. 1A, a packing carton 10 is provided, preferably having side apertures 12 and end apertures 14 as well as at least one sealable localized atmosphere communication aperture 16, preferably formed in an end 18

of carton **10**, near the top thereof. In accordance with a preferred embodiment of the invention, packing carton **10** need not be liquid impervious, such as a waxed container, and may thus be a relatively inexpensive uncoated and unwaxed cardboard box.

[0056] In accordance with a preferred embodiment of the invention, as shown in **FIG. 1B**, the sealable localized atmosphere communication aperture **16** preferably is sealed by attaching thereover a gas impervious sealing layer **20**, typically a self adhesive-coated plastic sticker. Sealing of aperture **16** may take place at any suitable time or location. Typically it is carried out during manufacture of the carton. Normally it is carried out prior to filling of the carton.

[0057] **FIG. 1C** shows insertion of a flexible bag **22**, such as a plastic bag, as a liner within carton **10**. The bag **22** is preferably a modified atmosphere bag, such as that described in assignee's U.S. patent application Ser. No. 08/918,584 to Moira M. Nir et al, assigned to StePac L. A., Ltd., Tefen Industrial Park, Tefen Western Galilee, Israel, the disclosure of which is hereby incorporated by reference. The bag **22**, and thus the carton **10**, is then filled with produce, as seen in **FIG. 1D**.

[0058] As seen in **FIG. 1E**, subsequent to or concurrently with filling the bag **22** with produce and prior to sealing of bag **22**, the portion of the bag **22** which lies adjacent aperture **16**, when the carton is filled with produce, is adhered to sealing layer **20**.

[0059] In the illustrated preferred embodiment of the present invention, where sealing layer **20** is an adhesive-coated plastic sticker, the adherence of bag **22** thereto may be achieved by manually pressing a suitable area of the bag **22** onto an adhesive-coated inside facing surface of sealing layer **20**, as shown in **FIG. 1E**.

[0060] It is appreciated that if sealing layer **20** is adhered to carton **10** during manufacture of the carton or at any stage prior to filling of the carton with produce, the adhesive-coated surface thereof which overlies aperture **16** must be protected, as by a removable release layer (not shown), which can be readily removed prior to the stage shown in **FIG. 1E**, preferably following the stage shown in **FIG. 1C**, so as to avoid inadvertent, undesired adherence between the layer **20** and a location on the bag **22** which is not the desired location.

[0061] Following adherence of the bag **22** to sealing layer **20**, or any equivalent adherence of the bag **22** to the carton **10** in the region of aperture **16**, the bag **22** and sealing layer **20** are apertured at aperture **16**, thereby defining an atmosphere communication pathway therethrough. One example of this functionality is illustrated in **FIG. 1F**, wherein a heated, preferably generally cylindrical aperturing element **24**, is inserted via aperture **16**, thus defining an aperture **25** through sealing layer **20** and the bag **22**. The aperture **25** is surrounded by an annular zone **26** of the sealing layer **20**. The bag **22** is sealed to sealing layer **20** at annular zone **26**.

[0062] It is appreciated that there may exist a large variety of techniques for defining the aperture **25** in the sealing layer **20** and the bag **22** in registration with aperture **16**. While it is believed that the technique described hereinabove with reference to **FIGS. 1A-1F** is preferred, the scope present invention need not be limited thereto.

[0063] Following completion of the stage shown in **FIG. 1F**, the bag **22** is sealed, as shown in **FIG. 1G**, and the carton **10** is closed.

[0064] Reference is now made to **FIGS. 2A-2C**, which are simplified pictorial illustrations of three stages in treating produce packaged in accordance with the embodiment of **FIGS. 1A-1G**.

[0065] As seen in **FIG. 2A**, the filled cartons **10**, each having an open aperture communicating with the interior of bag **22**, are preferably palletized and inserted into a treatment chamber **30**, such as a vacuum cooling chamber, a fumigation chamber, a gas treatment chamber or a chamber providing multiple functions, such as vacuum cooling and gas treatment. The arrangement of the cartons **10** within treatment chamber **30** is such that apertures **16** and thus the interiors of bags **22** within cartons **10** are all in fluid communication with the interior of treatment chamber **30**. In such a way, the contents of the bags **22** within cartons **10** are exposed to the environment of the interior of the treatment chamber **30**, as seen in **FIG. 2B** for a vacuum cooling application.

[0066] Following vacuum cooling and/or other treatment as shown in **FIGS. 2A and 2B**, but without requiring repalletization, the apertures **16** are preferably sealed by attaching a gas impermeable layer **40** onto the outside of the carton **10**, preferably over layer **20** as shown in **FIG. 2C**. This seals the interior of the bag **22** from the outside atmosphere, thereby enabling maintenance of a modified atmosphere within bag **22**.

[0067] Reference is now made to **FIGS. 3A-3C**, which are simplified pictorial illustrations of a methodology for loading a refrigerated container to provide maximum loading and cooling efficiency. As seen in **FIGS. 3A-3C**, pallets **100**, having loaded thereon ventilated cartons **102**, having ventilating apertures **104** formed in walls thereof, are loaded into a container **106** in a manner such that there is defined a central plenum **108** between two rows of loaded pallets **100**.

[0068] In a preferred embodiment of the invention, the interior width of the refrigerated container **106** is approximately 2.3 meters, the interior length of the container is approximately 11.6 meters and the pallets preferably have dimensions of 1 meter by 1.2 meters. The pallets **100** are preferably arranged in touching engagement with each other to define rows **110** and **112**, as seen in **FIGS. 3A and 3B**. Additionally, the pallets **110** and **112** are in touching engagement with the side walls of the container **106** (**FIGS. 3A and 3B**). The pallets in row **110** being arranged to have their relatively smaller dimension parallel to the longitudinal axis **114** of the container **106**, and the pallets in row **112** being arranged to have their relatively greater dimension parallel to the longitudinal axis **114** of the container **106** (**FIGS. 3A and 3B**).

[0069] Forced air output from a refrigeration unit **116** is supplied along channels **120** (**FIGS. 3A and 3C**) formed in a floor **130** of the container **106** and extending parallel to longitudinal axis **114** thereof, as illustrated by arrows **122**. This forced air rises through spaces **124** between adjacent floor elements **126** in the floor of the container **106**, except where physically blocked.

[0070] Thus, it may be appreciated that a major portion of the forced air rises relatively unimpeded from the channels

120, underlying the rows 110 and 112, through plenum 108 via elongate longitudinal openings 124 interconnecting channels 120 with plenum 108, as indicated by arrows 134.

[0071] Forced air also rises relatively unimpeded from the open ends 140 of channels 120 at the back end of the container into a plenum 142 defined rearwardly of rows 110 and 112 of pallets 110. Plenums 108 and 142 communicate with a plenum 144 at the top of the container above palletized cartons 102, and which serves as an air return plenum communicating with the refrigeration unit 116, as indicated by arrows 146. Typically air in air return plenum 144 is sucked into the refrigeration unit 116 under negative pressure.

[0072] Forced air also rises from various channels 120 via spaces 124 in a somewhat impeded manner via the interstices between adjacent palletized cartons 102 and eventually reaches air return plenum 144.

[0073] Additionally forced air rises alongside outer facing surfaces of palletized cartons 102 in vertical channels 150 typically formed by corrugations in the walls of the container 106 and reaches air return plenum 144. This flow preferably is not allowed to extend directly from channels 120 but rather is a negative pressure flow which draws cooled air via the interstices between cartons 102.

[0074] It is a particular feature of the present invention that generally horizontal air movement is provided through the ventilation openings 104 in the cartons 102 for efficient cooling of the contents thereof. This is true both in the atmosphere treatment described hereinabove with reference to FIGS. 2A-2C and in the refrigerated container loading and cooling arrangements described herein with reference to FIGS. 3A-3C. In the embodiment shown in FIGS. 3A-3C, the horizontal air movement is provided by suitable arrangement of the palletized cartons as described hereinabove and the definition of a plenum between rows of palletized cartons. Both the arrangement of the cartons on the pallets and the arrangement of the pallets in the container are important in this regard.

[0075] The various forced air flows described hereinabove cause air to penetrate through ventilating apertures 104 in palletized cartons 102 and thus to communicate with the interior of the cartons 102. In an embodiment where the cartons 102 contain a sealed bag therewithin, such as that shown in FIGS. 2A-2C, the exterior of the sealed bags is exposed to cooled air, for providing suitable cooling of the interior of the bags.

[0076] In accordance with a preferred embodiment of the present invention, spaces 124 which do not underlie pallets 100 are preferably blocked, as by provision of a flexible self-retaining blocking element, such as a closed cell sponge 160. Similarly, the end of plenum 108 is blocked as by provision of a sponge 160 and the exposed edges of the most rearward positioned pallets 100 in rows 110 and 112 are similarly blocked by sponges 160. This blocking and the above-described arrangement of pallets in the container 106 provides enhanced contact between air flows and the interiors of cartons 102 via apertures 104.

[0077] Reference is now made to FIG. 3D, which is a cross-sectional view of the container 106 and the pallets 100, taken along lines IIII-IIIID in FIG. 3A. In FIG. 3D it is seen that blocking elements 170 are attached to side walls 172 of

the upper deck of the pallet 100. On inserting the pallet 100 into the container 106, the blocking elements 170 form tight seals between the pallets 100 and side walls 174 of the container 106. The blocking elements 170 prevent the escape of the cooling air around the sides of the container 106 and ensures that the cooling air flows through the plenum 108 and the vertical channels 150 in order to provide efficient cooling to the produce contained within the cartons 102, as described hereinabove.

[0078] It is appreciated that the blocking elements 170 are preferably constructed of resilient material so as to provide adequate sealing between the carton rows 110 and 112 and the side walls 174 of the container 106, as illustrated in FIG. 3D.

[0079] Reference is now made to FIG. 4A, which shows a sealing element 50 for packaging produce in the carton 10, in accordance with a preferred embodiment of the present invention. The sealing element 50 comprises a sealing device 52, preferably in the shape of a ring. The sealing device 52 typically comprises locking elements 54 and 56 for sealing the bag 22 to the carton 10, as shown in FIG. 4A. A plug member 58 with sealing member 60, is pushed into the aperture 25, as illustrated in FIG. 4A, to seal the inside of the carton 10 from the outside environment.

[0080] Reference is now made to FIG. 4B, which shows another type of sealing element 70 for packaging produce in the carton 10, in accordance with another preferred embodiment of the invention. The sealing element 70 comprises a clasp 72, with a screw head 74, which is inserted into the aperture 25. A ring 76 is screwed onto the clasp 72 thus sealing the bag 22 to the carton 10, as shown in FIG. 4B. A cover member 78 with a sealing member 80 is pushed into the aperture 25, thereby sealing the inside of the carton 10 from the outside environment.

[0081] It is appreciated that the shapes of the sealing elements described hereinabove are constructed so as to conform to the shape and dimensions of the carton 10.

[0082] It is also appreciated that the embodiments described hereinabove, for sealing the bag 22 to the carton 10, are suitable for any type of receptacle, such as corrugated carton, plastic boxes or any type of agricultural storage container, which is used for packaging agricultural produce, as is known in the art.

[0083] It will be appreciated by persons skilled in the art that the present invention is not limited by what has been particularly shown and described hereinabove. Rather the scope of the present invention includes both combinations and subcombinations of the various features described hereinabove as well as variations and modifications which would occur to persons skilled in the art upon reading the specification and which are not in the prior art.

1. A method for packing agricultural produce comprising the steps of:

providing a container having at least one communications aperture formed in a wall thereof;

providing at least one flexible controlled permeability bag within said container;

- providing at least one bag aperture in said at least one flexible controlled permeability bag in general registration with said at least one communications aperture;
- sealing said produce inside said at least one flexible controlled permeability bag within said container, while leaving said at least one bag aperture and said at least one communications aperture open;
- providing atmosphere treatment within said at least one bag via said at least one bag aperture and said at least one communications aperture; and
- sealing at least one of said at least one bag aperture and said at least one communications aperture.
- 2.** A method for packing agricultural produce according to claim 1 and wherein said atmosphere treatment comprises vacuum cooling.
- 3.** A method for packing agricultural produce according to claim 1 or claim 2 and wherein said atmosphere treatment comprises fumigation.
- 4.** A method for packing agricultural produce according to any of the preceding claims and wherein said atmosphere treatment comprises gas treatment.
- 5.** A method for packing agricultural produce according to any of the preceding claims and wherein said at least one communications aperture formed in a wall thereof is formed in a sealing layer adhered to a wall of said container.
- 6.** A method for packing agricultural produce according to any of the preceding claims and wherein said flexible controlled vapor selective permeability bag comprises a gas impermeable bag.
- 7.** A method for packing agricultural produce according to any of claims 1 to 5 and wherein said flexible controlled vapor selective permeability bag comprises a gas permeable bag having selected permeability characteristics adapted to a given type of produce.
- 8.** A method for packing agricultural produce according to any of the preceding claims and wherein said providing at least one bag aperture in said flexible controlled permeability bag in general registration with said at least one communications aperture comprises:
- inserting said bag into said container;
 - at least partially filling said bag with said produce;
 - adhering said bag to said container adjacent said at least one communications aperture; and
 - aperturing said bag generally in registration with said at least one communications aperture.
- 9.** A method for packing agricultural produce according to claim 5 and wherein said providing at least one bag aperture in said flexible controlled permeability bag in general registration with said at least one communications aperture comprises:
- inserting said bag into said container;
 - at least partially filling said bag with said produce;
 - adhering said bag to said container adjacent said at least one communications aperture; and
 - aperturing said bag and said sealing layer in a single operation.
- 10.** A method for packing agricultural produce according to any of the preceding claims and wherein said sealing at least one of said at least one bag aperture and said at least one communications aperture comprises attaching an adhesive sticker over said at least one communications aperture from the outside of said container.
- 11.** A method for packing agricultural produce according to any of claims 1 to 5 or claim 8 and wherein said flexible controlled gas selective permeability bag comprises a gas impermeable bag.
- 12.** A method for packing agricultural produce according to any of claims 1 to 5 or claim 8 and wherein said flexible controlled gas selective permeability bag permeability bag comprises having selected permeability characteristics adapted to a given type of produce.
- 13.** A method for packing agricultural produce according to any of the preceding claims and wherein said sealing at least one of said at least one bag aperture and said at least one communications aperture comprises attaching a cap over said at least one communications aperture from the outside of said container.
- 14.** A carton suitable for packing agricultural produce and comprising at least one sealable localized atmosphere communication aperture formed in a wall thereof.
- 15.** A carton according to claim 14 and also comprising a plurality of ventilation apertures formed in at least one wall thereof.
- 16.** A carton according to claim 14 or claim 15 and also comprising a gas impervious layer arranged for sealing engagement with said at least one sealable localized atmosphere communication aperture.
- 17.** A carton according to claim 16 and also comprising an interiorly disposed bag.
- 18.** A carton according to claim 17 and wherein said bag is a modified atmosphere bag.
- 19.** A carton according to claim 16 and wherein said sealing layer is an adhesive-coated plastic sticker.
- 20.** A carton according to claims 17 and 19 and wherein said bag is adhered to said adhesive-coated plastic sticker.
- 21.** A carton according to claim 20 and wherein said bag and said adhesive-coated sticker are both apertured adjacent said sealable localized atmosphere communication aperture, thereby to provide a fluid communication pathway between the interior of the bag and the exterior of the carton.
- 22.** A carton according to claim 21 and also comprising a further gas impervious sealing layer sealably engaging said adhesive-coated sticker, thereby sealing the interior of the bag from the exterior of the carton.
- 23.** A carton according to claim 17 and claim 18 and wherein said bag is filled with agricultural produce.
- 24.** A carton according to claim 16 and wherein said sticker comprises selective permeability properties.
- 25.** A carton according to claim 19 and wherein said sticker comprises selective permeability properties.
- 26.** A carton according to claim 20 and wherein said sticker comprises selective permeability properties.
- 27.** A system for packing agricultural produce comprising:
- at least one container having at least one communications aperture formed in a wall thereof;
 - at least one flexible controlled permeability bag within said container, said at least one bag having an aperture in general registration with said at least one communications aperture and being adapted for containing said produce inside said at least one flexible controlled permeability bag within said container, while leaving

said at least one bag aperture and said at least one communications aperture open;

treatment functionality, operative for providing atmosphere treatment within said at least one bag via said at least one bag aperture and said at least one communications aperture; and

sealing functionality for sealing at least one of said at least one bag aperture and said at least one communications aperture.

28. A system for packing agricultural produce according to claim 27 and wherein said atmosphere treatment comprises vacuum cooling.

29. A system for packing agricultural produce according to claim 27 or claim 28 and wherein said atmosphere treatment comprises fumigation.

30. A system for packing agricultural produce according to any of claims 27 to 29 and wherein said atmosphere treatment comprises gas treatment.

31. A system for packing agricultural produce according to any of claims 27 to 30 and wherein said at least one communications aperture formed in a wall thereof is formed in a sealing layer adhered to a wall of said container.

32. A system for packing agricultural produce according to any of claims 27 to 31 and wherein said flexible controlled permeability bag comprises a modified atmosphere bag.

33. A system for packing agricultural produce according to any of claims 27 to 32 and wherein said flexible controlled permeability bag comprises a gas permeable bag having selected permeability characteristics adapted to a given type of produce.

34. A system for packing agricultural produce according to any of claims 27 to 33 and wherein said at least one bag aperture is formed in said flexible controlled permeability bag in general registration with said at least one communications aperture by the following functionality:

inserting said bag into said container;

at least partially filling said bag with said produce;

adhering said bag to said container adjacent said at least one communications aperture; and

aperturing said bag generally in registration with said at least one communications aperture.

35. A system for packing agricultural produce according to any of claims 27 to 34 and wherein said sealing at least one of said at least one bag aperture and said at least one communications aperture is effected by the following functionality:

attachment of an adhesive sticker over said at least one communications aperture from the outside of said container.

36. A method for loading a refrigerated container having a refrigeration unit producing a flow of forced air and a flow of return air under negative pressure in order to provide maximum loading and cooling efficiency, the method comprising:

loading palletized ventilated cartons having ventilating apertures formed in walls thereof into a refrigerated shipping container in a manner such that there is defined a central plenum between rows of loaded pallets; and

selectively blocking air passages inside said container such that said forced air flow is directed principally through said plenum and through interstices between ones of said ventilated containers and thus generally horizontally through said ventilating apertures.

37. A method according to claim 36 and wherein:

a forced air flow from said refrigeration unit is supplied along channels formed in a floor of the container and extending parallel to a longitudinal axis thereof;

at least a portion of said forced air output rises through spaces between adjacent floor elements in the floor of the shipping container, except where physically blocked and relatively unimpeded from a channel underlying said plenum; and

at least a portion of said forced air output rises relatively unimpeded from open ends of said channels at a back end of the container into back plenum defined rearwardly of said rows of pallets

38. A loaded refrigerated container having a refrigeration unit producing a flow of forced air and a flow of return air under negative pressure in order to provide maximum loading and cooling efficiency, the loaded container also comprising:

palletized ventilated cartons having ventilating apertures formed in walls thereof positioned in said refrigerated shipping container in a manner such that there is defined a central plenum between rows of loaded pallets and wherein

air passages inside said container are selectively blocked, such that said forced air flow is directed principally through said plenum, through interstices between ones of said ventilated containers and thus generally horizontally through said ventilating apertures.

39. A loaded refrigerated container according to claim 38 and wherein:

a forced air flow from said refrigeration unit is supplied along channels formed in a floor of the container and extending parallel to a longitudinal axis thereof;

at least a portion of said forced air output rises through spaces between adjacent floor elements in the floor of the shipping container, except where physically blocked and relatively unimpeded from a channel underlying said plenum; and

at least a portion of said forced air output rises relatively unimpeded from open ends of said channels at a back end of the container into back plenum defined rearwardly of said rows of pallets

* * * * *