

No. 673,291.

Patented Apr. 30, 1901.

F. L. SANDOZ.
APPLIANCE FOR EXPRESS CAR DOORS.

(Application filed May 5, 1900.)

(No Model.)

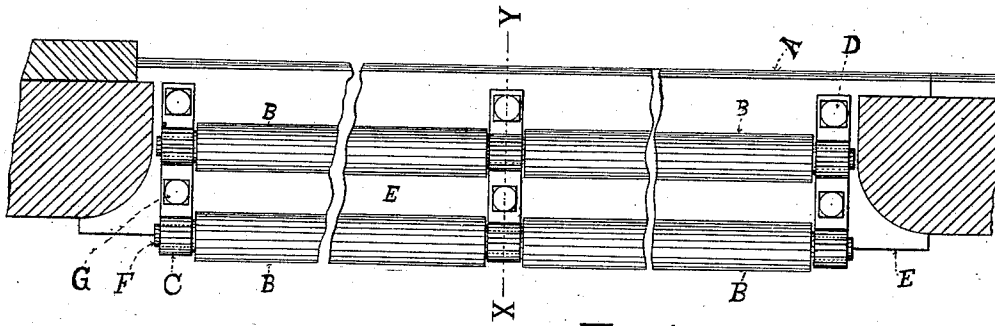

Fig. 1.

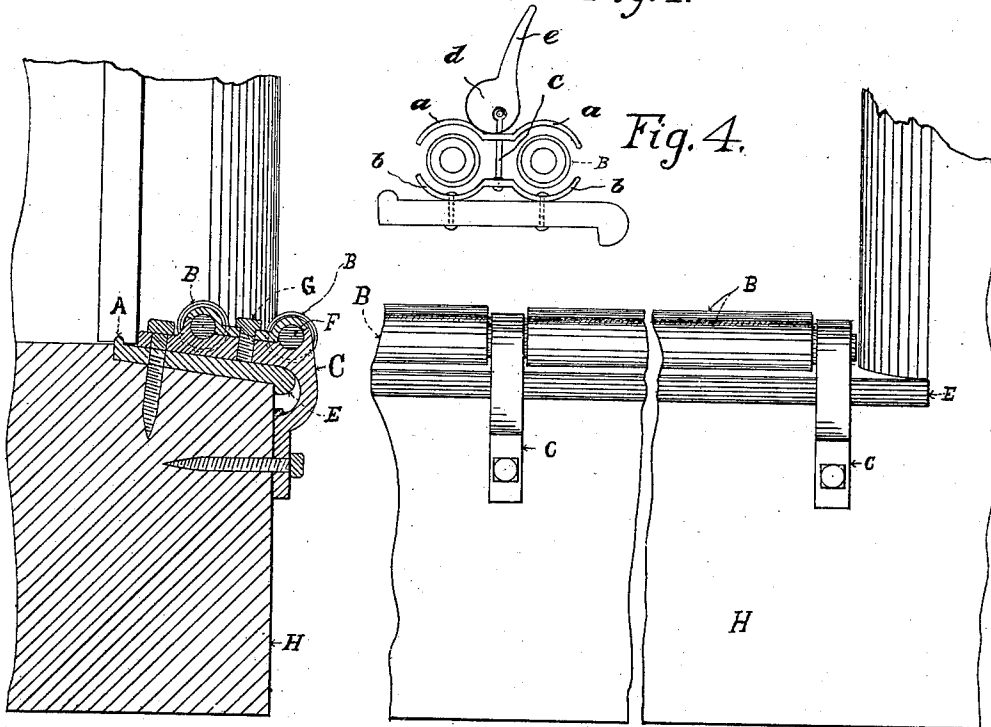

Fig. 2.

Fig. 3.

WITNESSES
F. L. Sandoz
F. L. Sandoz

F. L. Sandoz
INVENTOR.

UNITED STATES PATENT OFFICE.

FREDERICK L. SANDOZ, OF OPELOUSAS, LOUISIANA.

APPLIANCE FOR EXPRESS-CAR DOORS.

SPECIFICATION forming part of Letters Patent No. 673,291, dated April 30, 1901.

Application filed May 5, 1900. Serial No. 15,635. (No model.)

To all whom it may concern:

Be it known that I, FREDERICK LANDON SANDOZ, a citizen of the United States, residing at Opelousas, in the parish of St. Landry and State of Louisiana, have invented a new and useful Appliance for Express-Car Doors, of which the following is a specification.

My invention relates to an appliance for express-car doors for the purpose of loading and unloading and lessening the damage to fragile packages.

The appliance is fastened to the car-door sill by bolts passing through castings having journals or boxes supporting rollers covered with rubber or any other substance of a similar nature having a cushion-like structure. The boxes or journals are so constructed as to allow of the rollers being easily removed, and the appliance is furnished with a clamp or brake to prevent the rollers from turning when not in use. The roller can be in one length or in several lengths across the car-door, each set having separate boxes and clamps or brakes. I attain these objects by the mechanism illustrated in the accompanying drawings, in which—

Figure 1 is a top view or plan. Fig. 2 is a vertical section through the appliance, taken at X Y on Fig. 1. Fig. 3 is an elevation of a part of the appliance looking toward the car. Fig. 4 is a view showing one method of clamping the rollers and is referred to herein as a "brake" or "clamp."

Similar letters refer to similar parts throughout the several views.

The rollers B, Figs. 1 and 3, are journaled into the castings or boxes C, as shown at F, Fig. 2. The castings or boxes C are bolted to the top of the door-sill E and at the sides of the car H. The bolts G hold the top or cover of the boxes and facilitate the removal

of the rollers. The rollers B are covered with a yielding substance, preferably rubber, to break the shock or fall of a body falling on it in loading and unloading an express-car, for which purpose the appliance is intended.

In Fig. 4 is shown a clamping device attached to the door-sill at either end. Said clamp consists of pairs of curved arms *a*, *b*, arranged one above the other, having passing through the central portions thereof a rod *c*, which projects above the arms *a* and is provided with a bearing to which is pivoted a cam *d*, having an operating-lever *e*. Interposed between the arms *a* and *b* are the rollers B. When it is desired to prevent the rollers from revolving when not in use, the enlarged portion of the cam is pressed down on the central portions of the arms *a*, which brings the curved portions thereof in contact with the surfaces of the rollers, whereby they are clamped to the said arms *a*.

What I claim as my invention, and desire to secure by Letters Patent, is—

In a device of the character described, the combination with the door-sill of an express-car, having secured thereto bearing-boxes, with rollers journaled therein, said rollers, being covered with elastic material, of a clamping device, having the rollers, interposed between the arms thereof, whereby the said clamp is adapted to prevent said rollers from rotating, substantially as specified.

In witness whereof I have hereunto set my hand, on this 28th day of the month of April, A. D. 1900, in the presence of the two subscribing witnesses.

F. L. SANDOZ.

Witnesses:

G. A. SANDOZ,
CHAS. J. ROBIN.