

(19) World Intellectual Property Organization
International Bureau



(43) International Publication Date
28 June 2001 (28.06.2001)

PCT

(10) International Publication Number
WO 01/47027 A1

- (51) International Patent Classification⁷: H01L 29/78, 29/10
Adrianus, W.; Prof. Holstlaan 6, NL-5656 AA Eindhoven (NL).
- (21) International Application Number: PCT/EP00/12255
(74) Agent: HOUBIERS, Ernest, E., M., G.; Internationaal Octrooibureau B.V., Prof Holstlaan 6, NL-5656 AA Eindhoven (NL).
- (22) International Filing Date: 5 December 2000 (05.12.2000)
- (25) Filing Language: English
(81) Designated States (*national*): JP, KR.
- (26) Publication Language: English
(84) Designated States (*regional*): European patent (AT, BE, CH, CY, DE, DK, ES, FI, FR, GB, GR, IE, IT, LU, MC, NL, PT, SE, TR).
- (30) Priority Data:
99204405.7 20 December 1999 (20.12.1999) EP
Published:
— With international search report.
— Before the expiration of the time limit for amending the claims and to be republished in the event of receipt of amendments.
- (71) Applicant: KONINKLIJKE PHILIPS ELECTRONICS N.V. [NL/NL]; Groenewoudseweg 1, NL-5621 BA Eindhoven (NL).

(72) Inventors: MEEUWSEN, Constantinus, P.; Prof. Holstlaan 6, NL-5656 AA Eindhoven (NL). LUDI KHUIZE,
For two-letter codes and other abbreviations, refer to the "Guidance Notes on Codes and Abbreviations" appearing at the beginning of each regular issue of the PCT Gazette.

(54) Title: SEMICONDUCTOR DEVICE

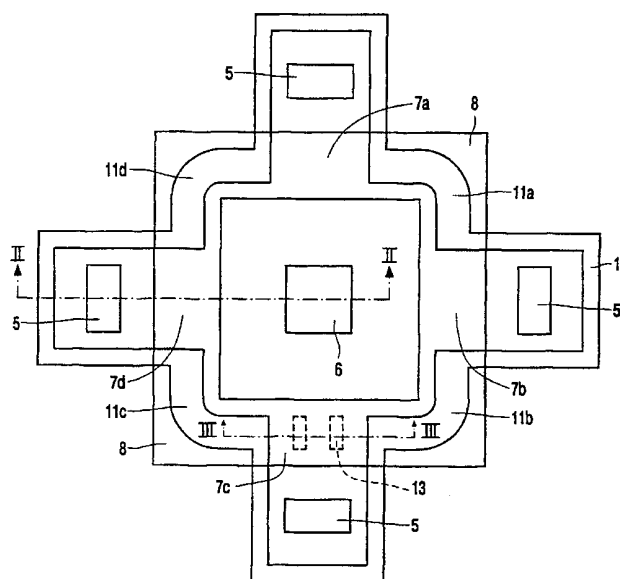

(57) Abstract: The invention relates to a high-voltage deep depletion transistor, provided in a semiconductor body (1) having a substrate (2) of a first conductivity type, for example the p-type, and a surface layer (3) of the opposite conductivity type, for example the n-type for an n-channel transistor. To prevent formation of inversion layers below the gate, the channel is subdivided into a plurality of sub-channel regions (7a, 7b, 7c, 7d) mutually separated by p-type regions (11a, 11b, 11c, 11d) which serve to remove generated holes. The p-type regions extend across the whole thickness of the channel and are contacted via the substrate. Each sub-channel region may be subdivided further by intermediate p-type regions (13) to improve the removal of holes.

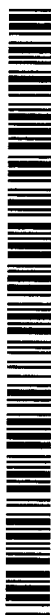

WO 01/47027 A1

Semiconductor device

The invention relates to a semiconductor device with a MOS transistor of the depletion type comprising a semiconductor body with a substrate of a first conductivity type provided with a layer of the opposed, the second conductivity type adjoining a surface of said semiconductor body, in which layer a source zone of the second conductivity type, a drain
5 zone of the second conductivity type, and an interposed channel region of the second conductivity type are defined, while a gate electrode is provided above the channel region, electrically insulated therefrom by an insulating layer, and the semiconductor body is further provided with a zone of the first conductivity type which forms a pn junction with the channel region and which adjoins the surface for the removal of minority charge carriers
10 from the channel region. Such a device is known inter alia from the patent document US-A 4,868,620.

Such transistors, often referred to as deep depletion MOST, may be used to advantage in high-voltage circuits, for example for deriving a lower voltage from the high supply voltage while connected as a source follower, which lower voltage may be used as a
15 supply voltage for a low-voltage portion which is often present in an integrated high-voltage circuit.

In the semiconductor device known from the US patent cited above, the semiconductor layer adjoining the surface is formed by an n-type epitaxial silicon layer provided on a p-type silicon substrate. An island is defined in the epitaxial layer by deep p-
20 type insulation zones, in which island the source and drain are formed as strongly doped n-type zones, separated from one another by an n-type channel region with a lower doping level and an adjoining drift region. A gate electrode, separated from the channel by an oxide layer, is provided above the channel layer.

The current between source and drain in such a transistor is controlled by
25 means of a depletion region which is induced in the channel by the voltage at the gate. At higher voltages, the operation may be hampered by the generation of minority charge carriers (holes in the case of an n-channel transistor), which form an inversion layer below the gate and screen off the latter from the channel, so that it is no longer possible inter alia to bring the transistor into the pinch state. To prevent an inversion occurring below the gate, the patent

document US-A 4,868,620 proposes the provision of a discharge for minority charge carriers in the form of a p-type surface zone. A suitable low voltage is applied to this zone via an electrical connection such that holes are removed across the blocked pn junction. To prevent punch-through between this discharge zone and the subjacent p-type substrate, a strongly doped n-type buried layer is provided below the zone between the epitaxial layer and the substrate, screening off the substrate from the epitaxial layer locally.

The zone forming a discharge for minority charge carriers in this known transistor is provided in the current path between source and drain and accordingly influences various electrical properties of the transistor to a non-negligible degree, for example its resistance, which is undesirable from a viewpoint of design technology. In addition, the construction of the transistor requires the availability of an epitaxial layer because of the presence of a buried layer, which means that it is not or hardly possible to provide the semiconductor layer, for example, in the form of an implanted layer.

The invention has for its object inter alia to provide a semiconductor device of the kind described in the opening paragraph in which the transistor is provided with a charge removal facility for minority carriers which is not situated in the current path between source and drain. The invention further has for its object to provide a transistor with a construction which allows of a higher flexibility in the manufacturing process than does the known transistor.

According to the invention, a semiconductor device of the kind mentioned in the opening paragraph is for this purpose characterized in that the channel region comprises two or more sub-regions which are mutually separated by said surface zone of the first conductivity type, which surface zone extends from the surface transversely across the thickness of the layer of the second conductivity type up to the substrate of the first conductivity type. The current path between source and drain in this device does not run below the removal facility for minority charge carriers, but instead next to this zone or between two zones in the case of several discharge zones distributed over the width of the channel, so that the resistance of the channel is substantially defined by the channel width. Since the removal zone for minority charge carriers is connected to the substrate of the same conductivity type, it is not necessary to provide the removal zone with a connection to the surface of the semiconductor body, but the minority charge carriers can be discharged via the substrate. In addition, it is not necessary to form a buried screening zone between the removal zone for minority charge carriers and the substrate, so that the semiconductor layer may be formed not only by epitaxy but also by means of ion implantation.

An embodiment which has the advantage that the pinch voltage is defined by the vertical depletion region induced by the insulated gate and not by the lateral depletion region induced by the surface zone is characterized in that the sub-regions of the channel region have a width which is greater than the thickness of the channel region and in comparison with said thickness is so great that the transistor is pinched by the depletion region induced by the gate.

Although alternative designs may also be used to advantage, special advantages are obtained in embodiments wherein a subdivided channel region and a subdivided surface zone of the first conductivity type in conjunction form a closed structure around the drain (or the source), as seen at the surface, while the source (or the drain) zone is situated outside this closed structure. A preferred embodiment of such a device is characterized in that the channel region, seen in plan view, has the shape of a polygon in which that portion of the semiconductor layer which is enclosed by the polygon comprises the drain and that portion of the semiconductor layer which is situated outside the polygon comprises the source, while a number of surface zones of the first conductivity type are present for the removal of minority charge carriers, which surface zones are present at the corners of the polygon, and the sub-regions of the channel region are situated at the lateral sides of the polygon. Preferably, the polygon is formed by a regular polygon, for example a square. A further embodiment is characterized in that the lateral sides of the polygon are each provided with at least one further surface zone of the first conductivity type which extends transversely across the thickness of the semiconductor layer for the purpose of removal of minority charge carriers.

These and other aspects of the invention will be explained in more detail below with reference to an embodiment. In the drawing:

Fig. 1 is a plan view of a semiconductor device according to the invention;

Fig. 2 is a cross-sectional view of this device taken on the line II-II in Fig. 1;

Fig. 3 is a cross-sectional view of this device taken on the line III-III in Fig. 1;

and

Fig. 4 is a cross-sectional view of a further embodiment of a semiconductor device according to the invention.

It is noted that the drawing is diagrammatic only and not true to scale. It is also noted that the drawing only shows an MOS transistor, but it will be obvious without further

explanation that a large number of other circuit elements may be provided in the same semiconductor body in addition to the transistor shown here, which elements are not shown in the drawing and are not discussed in any detail further below because they have a construction which is usual and known per se.

5 The device comprises a semiconductor body 1 which is made of silicon in the present example but which may obviously also be made of some other suitable semiconductor material. The body 1 comprises a substrate 2 of a first conductivity type, in this example the p-type, with a resistivity of, for example, 100 Ω .cm. An n-type epitaxial silicon layer 3 with a thickness of, for example 10 μ m and a doping of 1.5×10^{15} atoms per
10 cm^3 is provided on the substrate. Instead of this epitaxial layer, an epitaxial layer having a lower doping level may be used, in which the doping is locally enhanced by means of an n-well implantation. A buried layer 4 of the p-type is provided between the epitaxial layer 3 and the substrate 2. This layer is not always necessary, but it offers advantages at very high voltages because the presence of the buried layer 4 leads to a better distribution of the electric
15 field, which is favorable for the breakdown voltage of the transistor. The transistor comprises a source and a drain which are formed by strongly doped n-type surface zones 5 and 6 provided in the epitaxial layer. The zones 5 and 6 are provided with contacts in a usual manner, which contacts are depicted diagrammatically only in Fig. 2. A channel region 7 formed by a portion of the epitaxial layer 3 lies between the source and the drain. The
20 conduction through the channel 7 is controlled by (apart from the substrate voltage) the voltage applied to the gate electrode 8, said gate voltage inducing a depletion region in the channel 7 whereby the channel can be fully pinched. Such a transistor is often referred to as "deep depletion transistor" in the literature. The gate 8 is electrically insulated from the channel region 7 by a gate dielectric 9 which in this example is formed by a layer of silicon
25 oxide with a thickness of approximately 0.8 μ m. A drift region 10 lies between the drain 6 and the channel 7 and is formed by a portion of the epitaxial layer 3. The length of the drift region is determined by the maximum voltage applied to the drain 6. In a specific embodiment in which this voltage was 700 V, the length of the drift region was approximately 70 μ m. When such a high voltage is applied, with a comparatively low voltage
30 at gate 8, it is possible that an inversion layer of holes is formed below the gate at the boundary between the channel 7 and the oxide layer 9, in the location having the lowest potential. This inversion layer may prevent the channel below the gate from being pinched, and may thus prevent a correct functioning of the transistor. The formation of the inversion layer can be prevented in that a p-type zone 11 adjoining the surface of the semiconductor

body is provided in the n-type epitaxial layer 3, as proposed in the cited US patent US-A 4,868,620, and, according to the invention, which forms a pn junction 12 next to the channel region 7, see Fig. 3. The application of a reverse bias voltage across the pn junction 12 causes the holes generated in or adjacent the channel region to be removed. According to the invention, the channel region 7 comprises a number of sub-regions, referenced 7a, 7b, 7c, and 7d in Fig. 1, which are mutually separated by interposed regions of said p-type surface zone 11. The sub-zones of the surface zone 11 are referenced 11a, 11b, 11c, and 11d in that order in Fig. 1. The zones 11a, 11b, 11c, and 11d extend transversely across the thickness up to the p-type substrate and thus at the same time insulate the sub-channels 7a, 7b, 7c, and 7d from portions of the epitaxial layer situated outside the transistor. Since the sub-zones 11a, 11b, etc. are conductively connected to the substrate 2, it is not necessary to provide these zones with separate contacts. During operation, the holes can be removed through the sub-zones 11a, 11b, etc. and through the substrate 2, where usually the lowest voltage is applied. The width of each sub-channel 7a, 7b, etc. is preferably chosen such that a laterally directed electric field is present across the entire or at least substantially the entire width of the sub-channels below the gate, which field drives the holes to the zones 11. At the doping concentration chosen for the epitaxial layer 3, it is found to be advantageous to choose the widths of the sub-channels 7a, 7b, etc. to be not greater than approximately 50 μm . Great widths are possible with the use of additional sub-zones 13 which may be provided in the sub-channels 7a, 7b, etc. Such zones 13 are shown in Fig. 1 and Fig. 3 with broken lines for illustration (only in sub-channel 7c to keep the drawing simple, but they should obviously also be provided in the other sub-channels having the same width as channel 7c). The zones 13 also extend transversely across the thickness of the layer 3 up to the substrate 2.

Since the transistor channel is composed of a number of sub-channels which are laterally bounded by hole-removal zones, the current from the source to the drain is conducted not below but between said zones, so that transistor parameters such as the resistance or the pinch voltage are not or only to a minor degree influenced by the presence of the hole-removal zones. The transistor is for this purpose constructed in a special layout of polygonal shape, in this example a regular quadrangle, defined by the p-type zones 11a, 11b, etc. The drain 6 is situated in the central portion of the epitaxial layer 3 surrounded by the quadrangle. The source is situated outside the quadrangle. The p-type zones 11 are situated at the corner points of the quadrangle, the sub-regions 7a, 7b, 7c, and 7d lie on the lateral sides of the quadrangle. The zones 11 also extend around the source zones 5 so as to insulate the

source 5 electrically from the rest of the circuit, thus defining an electrically insulated island within which the entire transistor is situated.

In the example described here, the layer 3 is formed by an epitaxial layer, which renders it possible to provide a buried layer 4 locally between the epitaxial layer 3 and the substrate 2. This layer has the same conductivity type as the substrate 2, but a higher doping level. The breakdown voltage of the transistor can be increased by means of the layer 4, as is known, owing to a better distribution of the potential lines. The transistor may be manufactured by methods other than epitaxy, as illustrated in Fig. 4, in those cases in which such a buried layer is not necessary. This Figure shows a modification of the device of the first embodiment in a cross-section corresponding to the cross-section shown in Fig. 3. The layout of the transistor of Fig. 4 is presumed to be identical to that of Fig. 1. The embodiment of Fig. 4 differs from the preceding embodiment mainly in that the semiconductor body is almost entirely of the p-type, and the n-type layer in which the source, the drain, the channel region, and the drift region are formed is obtained through masked implantation of, for example, phosphorus or arsenic ions. Fig. 4 shows the sub-channel 7c which in its turn is subdivided into three sub-regions which are mutually separated by the hole-removal p-type regions 13. The regions 13 are formed by portions of the p-type semiconductor body which were not redoped during the n-implantation or by an additional p-type implantation, as are the p-type regions 11c and 11d which laterally bound the sub-channel 7c.

20

It will be obvious that the invention is not limited to the examples given here but that many more variations are possible to those skilled in the art within the scope of the invention. Thus, for example, designs other than quadrangles or other regular polygons may be used for the transistor. It is possible, for example, to build up the transistor from a number of parallel sub-channels which are separated from one another by p-type zones for the removal of the holes. Alternatively, sub-channels may be provided, for example, at the corner points of the polygon. The invention may be applied to p-channel transistors instead of n-channel transistors, in which case the channel is formed by a p-type region, the minority charge carriers are electrons, and the electron-removal zones are n-type zones.

25

CLAIMS:

1. A semiconductor device with a MOS transistor of the depletion type comprising a semiconductor body with a substrate of a first conductivity type provided with a layer of the opposed, the second conductivity type adjoining a surface of said semiconductor body, in which layer a source zone of the second conductivity type, a drain zone of the second conductivity type, and an interposed channel region of the second conductivity type are defined, while a gate electrode is provided above the channel region, electrically insulated therefrom by an insulating layer, and the semiconductor body is further provided with a zone of the first conductivity type which forms a pn junction with the channel region and which adjoins the surface for the removal of minority charge carriers from the channel region, characterized in that the channel region comprises two or more sub-regions which are mutually separated by said surface zone of the first conductivity type, which surface zone extends from the surface transversely across the thickness of the layer of the second conductivity type up to the substrate of the first conductivity type.
2. A semiconductor device as claimed in claim 1, characterized in that the sub-regions of the channel region have a width which is greater than the thickness of the channel region and in comparison with said thickness is so great that the transistor is pinched by the depletion region induced by the gate.
3. A semiconductor device as claimed in claim 1 or 2, characterized in that the channel region, seen in plan view, has the shape of a polygon in which that portion of the semiconductor layer which is enclosed by the polygon comprises the drain and that portion of the semiconductor layer which is situated outside the polygon comprises the source, while a number of surface zones of the first conductivity type are present for the removal of minority charge carriers, which surface zones are present at the corners of the polygon, and the sub-regions of the channel region are situated at the lateral sides of the polygon.
4. A semiconductor device as claimed in claim 3, characterized in that the polygon is a regular polygon.

5. A semiconductor device as claimed in claim 3 or 4, characterized in that the lateral sides of the polygon are each provided with at least one further surface zone of the first conductivity type which extends transversely across the thickness of the semiconductor layer for the purpose of removal of minority charge carriers.

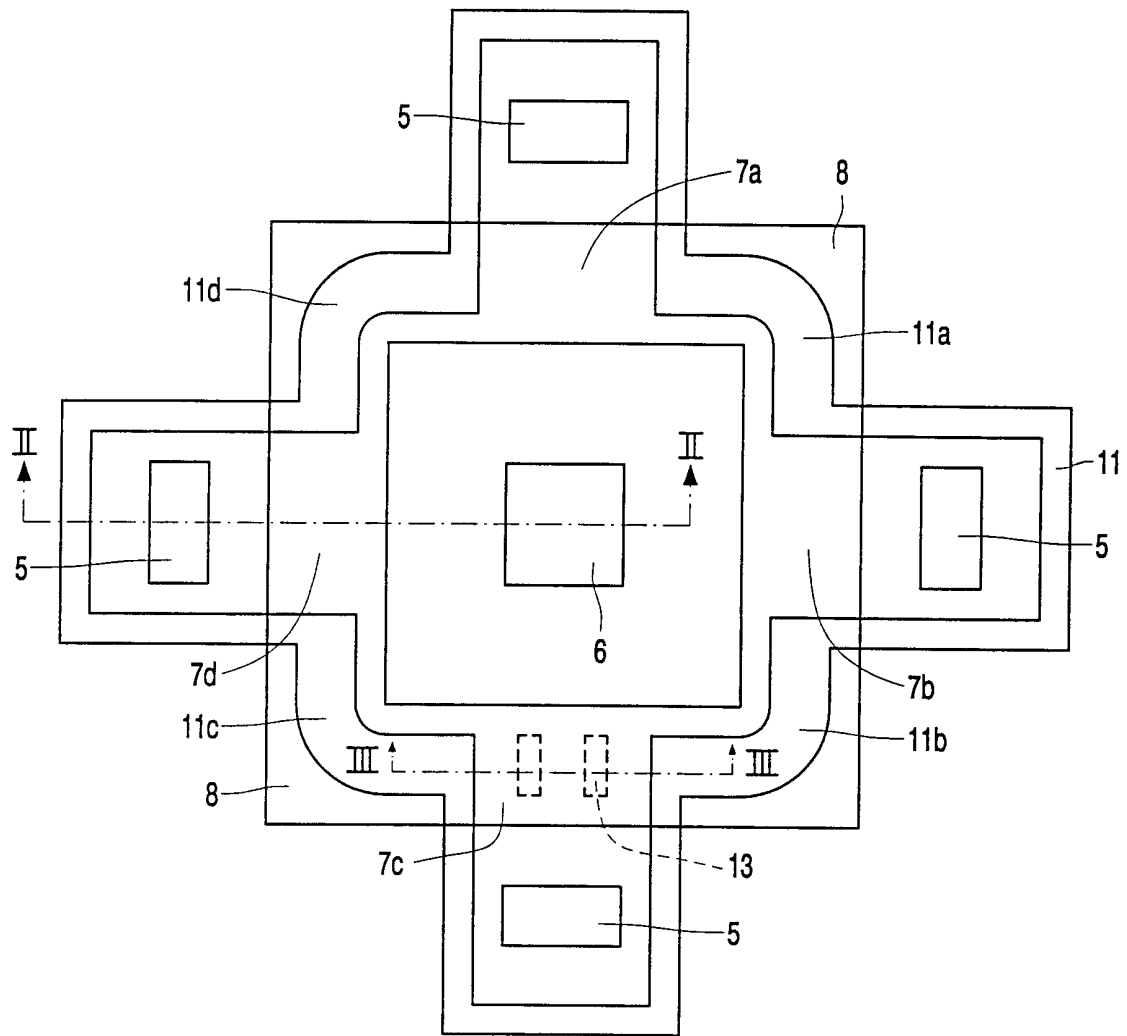

FIG. 1

2/2

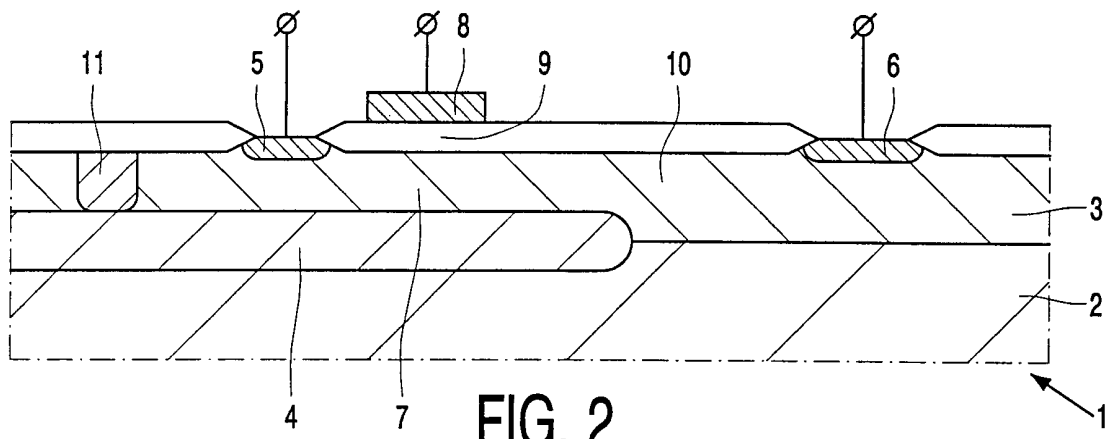

FIG. 2

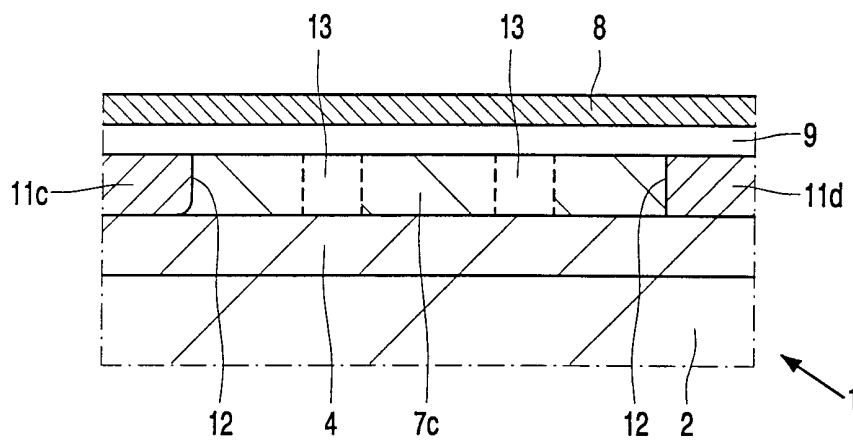

FIG. 3

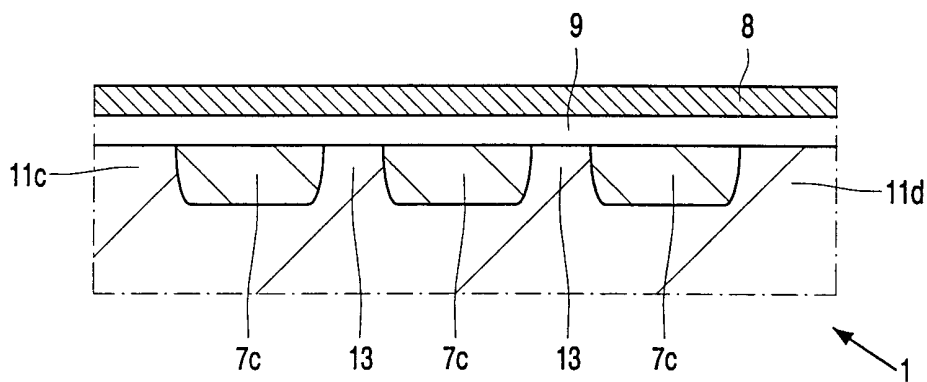

FIG. 4

INTERNATIONAL SEARCH REPORT

International Application No
PCT/EP 00/12255

A. CLASSIFICATION OF SUBJECT MATTER IPC 7 H01L29/78 H01L29/10				
According to International Patent Classification (IPC) or to both national classification and IPC				
B. FIELDS SEARCHED				
Minimum documentation searched (classification system followed by classification symbols) IPC 7 H01L				
Documentation searched other than minimum documentation to the extent that such documents are included in the fields searched				
Electronic data base consulted during the international search (name of data base and, where practical, search terms used) EPO-Internal				
C. DOCUMENTS CONSIDERED TO BE RELEVANT				
Category °	Citation of document, with indication, where appropriate, of the relevant passages	Relevant to claim No.		
X	PATENT ABSTRACTS OF JAPAN vol. 009, no. 295 (E-360), 21 November 1985 (1985-11-21) - & JP 60 134468 A (HITACHI SEISAKUSHO KK), 17 July 1985 (1985-07-17) abstract; figures 1,7 ---	1		
A	US 4 868 620 A (ADLER MICHAEL S ET AL) 19 September 1989 (1989-09-19) cited in the application abstract column 3, line 67 -column 4, line 10; figure 2 ---	1		
A	EP 0 841 702 A (SGS THOMSON MICROELECTRONICS) 13 May 1998 (1998-05-13) figures 8,9 -----	1,3,4		
<input type="checkbox"/> Further documents are listed in the continuation of box C. <input checked="" type="checkbox"/> Patent family members are listed in annex.				
° Special categories of cited documents :				
<table style="width: 100%; border: none;"> <tr> <td style="width: 50%; border: none; vertical-align: top;"> *A* document defining the general state of the art which is not considered to be of particular relevance *E* earlier document but published on or after the international filing date *L* document which may throw doubts on priority claim(s) or which is cited to establish the publication date of another citation or other special reason (as specified) *O* document referring to an oral disclosure, use, exhibition or other means *P* document published prior to the international filing date but later than the priority date claimed </td> <td style="width: 50%; border: none; vertical-align: top;"> *T* later document published after the international filing date or priority date and not in conflict with the application but cited to understand the principle or theory underlying the invention *X* document of particular relevance; the claimed invention cannot be considered novel or cannot be considered to involve an inventive step when the document is taken alone *Y* document of particular relevance; the claimed invention cannot be considered to involve an inventive step when the document is combined with one or more other such documents, such combination being obvious to a person skilled in the art. *&* document member of the same patent family </td> </tr> </table>			*A* document defining the general state of the art which is not considered to be of particular relevance *E* earlier document but published on or after the international filing date *L* document which may throw doubts on priority claim(s) or which is cited to establish the publication date of another citation or other special reason (as specified) *O* document referring to an oral disclosure, use, exhibition or other means *P* document published prior to the international filing date but later than the priority date claimed	*T* later document published after the international filing date or priority date and not in conflict with the application but cited to understand the principle or theory underlying the invention *X* document of particular relevance; the claimed invention cannot be considered novel or cannot be considered to involve an inventive step when the document is taken alone *Y* document of particular relevance; the claimed invention cannot be considered to involve an inventive step when the document is combined with one or more other such documents, such combination being obvious to a person skilled in the art. *&* document member of the same patent family
A document defining the general state of the art which is not considered to be of particular relevance *E* earlier document but published on or after the international filing date *L* document which may throw doubts on priority claim(s) or which is cited to establish the publication date of another citation or other special reason (as specified) *O* document referring to an oral disclosure, use, exhibition or other means *P* document published prior to the international filing date but later than the priority date claimed	*T* later document published after the international filing date or priority date and not in conflict with the application but cited to understand the principle or theory underlying the invention *X* document of particular relevance; the claimed invention cannot be considered novel or cannot be considered to involve an inventive step when the document is taken alone *Y* document of particular relevance; the claimed invention cannot be considered to involve an inventive step when the document is combined with one or more other such documents, such combination being obvious to a person skilled in the art. *&* document member of the same patent family			
Date of the actual completion of the international search <p style="text-align: center; font-weight: bold;">8 May 2001</p>	Date of mailing of the international search report <p style="text-align: center; font-weight: bold;">15/05/2001</p>			
Name and mailing address of the ISA European Patent Office, P.B. 5818 Patentlaan 2 NL - 2280 HV Rijswijk Tel. (+31-70) 340-2040, Tx. 31 651 epo nl, Fax: (+31-70) 340-3016	Authorized officer <p style="text-align: center; font-weight: bold;">Nesso, S</p>			

INTERNATIONAL SEARCH REPORT

Information on patent family members

International Application No

PCT/EP 00/12255

Patent document cited in search report	Publication date	Patent family member(s)	Publication date
JP 60134468 A	17-07-1985	NONE	
US 4868620 A	19-09-1989	NONE	
EP 0841702 A	13-05-1998	US 6043532 A JP 10233508 A	28-03-2000 02-09-1998