

(19) World Intellectual Property Organization
International Bureau



(43) International Publication Date
18 December 2003 (18.12.2003)

PCT

(10) International Publication Number
WO 03/104736 A1

(51) International Patent Classification⁷: F28F 1/42, B21C 37/20

(21) International Application Number: PCT/US03/18304

(22) International Filing Date: 10 June 2003 (10.06.2003)

(25) Filing Language: English

(26) Publication Language: English

(30) Priority Data: 60/387,328 10 June 2002 (10.06.2002) US

(71) Applicant (for all designated States except US): WOLVERINE TUBE, INC. [US/US]; 200 Clinton Avenue, Suite 1000, Huntsville, AL 35801 (US).

(72) Inventors; and

(75) Inventors/Applicants (for US only): THORS, Petur [US/US]; 4222 Willow Bend Road SE, Decatur, AL 35603 (US). ZOUBKOV, Nikolai [RU/RU]; Novoyarsenski Pr. 32-1-161, Moscow (RU).

(74) Agents: PRATT, John, S. et al.; Kilpatrick Stockton LLP, Suite 2800, 1100 Peachtree Street, Atlanta, GA 30309 (US).

(81) Designated States (national): AE, AG, AL, AM, AT, AU, AZ, BA, BB, BG, BR, BY, BZ, CA, CH, CN, CO, CR, CU, CZ, DE, DK, DM, DZ, EC, EE, ES, FI, GB, GD, GE, GH, GM, HR, HU, ID, IL, IN, IS, JP, KE, KG, KP, KR, KZ, LC, LK, LR, LS, LT, LU, LV, MA, MD, MG, MK, MN, MW, MX, MZ, NI, NO, NZ, OM, PH, PL, PT, RO, RU, SC, SD, SE, SG, SK, SL, TJ, TM, TN, TR, TT, TZ, UA, UG, US, UZ, VC, VN, YU, ZA, ZM, ZW.

(84) Designated States (regional): ARIPO patent (GH, GM, KE, LS, MW, MZ, SD, SL, SZ, TZ, UG, ZM, ZW), Eurasian patent (AM, AZ, BY, KG, KZ, MD, RU, TJ, TM), European patent (AT, BE, BG, CH, CY, CZ, DE, DK, EE, ES, FI, FR, GB, GR, HU, IE, IT, LU, MC, NL, PT, RO, SE, SI, SK, TR), OAPI patent (BF, BJ, CF, CG, CI, CM, GA, GN, GQ, GW, ML, MR, NE, SN, TD, TG).

Published:

- with international search report
- before the expiration of the time limit for amending the claims and to be republished in the event of receipt of amendments

For two-letter codes and other abbreviations, refer to the "Guidance Notes on Codes and Abbreviations" appearing at the beginning of each regular issue of the PCT Gazette.

(54) Title: HEAT TRANSFER TUBE AND METHOD OF AND TOOL FOR MANUFACTURING THE SAME

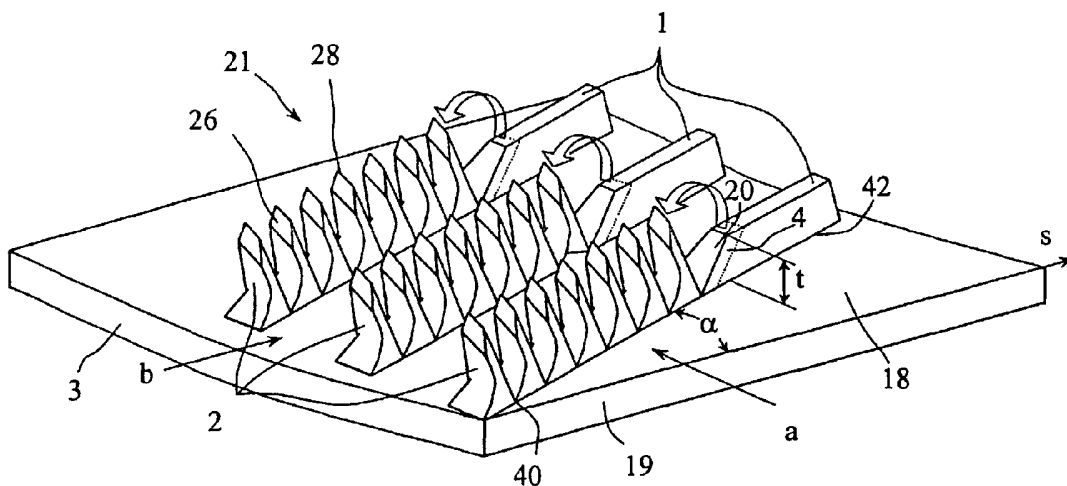

(57) Abstract: The inner surface of a heat transfer tube is enhanced with a plurality of protrusions (2) that create additional paths for fluid flow within the tube and thereby enhance turbulence of heat transfer mediums flowing within the tube. This increases fluid mixing to reduce the boundary layer build-up of the fluid medium close to the inner surface of the tube, such build-up increasing the resistance and thereby impeding heat transfer. The protrusions (2) also provide extra surface area for additional heat exchange. The method of this invention includes using a tool, which can easily be added to existing manufacturing equipment, having a cutting edge to cut through ridges on the inner surface of the tube to create ridge layers and a lifting edge to lift the ridge layers to form the protrusions (2). In this way, the protrusions (2) are formed without removal of metal from the inner surface of the tube, thereby eliminating debris which can damage the equipment in which the tubes are used.



WO 03/104736 A1

HEAT TRANSFER TUBE AND METHOD OF AND TOOL FOR MANUFACTURING THE SAME

5

Field of the Invention

This invention relates to a heat transfer tube having protrusions on the inner surface of the tube and a method of and tool for forming the protrusions on the inner surface of the tube.

Background of the Invention

10

This invention relates to a heat transfer tube having an enhanced inner surface to facilitate heat transfer from one side of the tube to the other. Heat transfer tubes are commonly used in equipment, such as, for example, flooded evaporators, falling film evaporators, spray evaporators, absorption chillers, condensers, direct expansion coolers, and single phase coolers and heaters, used in the refrigeration, chemical, petrochemical, and food-processing industries. A variety of heat transfer mediums may be used in these applications, including, but not limited to, pure water, a water glycol mixture, any type of refrigerant (such as R-22, R-134a, R-123, etc.), ammonia, petrochemical fluids, and other mixtures.

15

An ideal heat transfer tube would allow heat to flow completely uninhibited from the interior of the tube to the exterior of the tube and vice versa. However, such free flow of heat across the tube is generally thwarted by the resistance to heat transfer. The overall resistance of the tube to heat transfer is calculated by adding the individual resistances from the outside to the inside of the tube or vice versa. To improve the heat transfer efficiency of the tube, tube manufacturers have striven to uncover ways to reduce the overall resistance of the tube. One such way is to enhance the outer surface of the tube, such as by forming fins on the outer surface. As a result of recent advances in enhancing

25

the outer tube surface (see, e.g., U.S. Patent Nos. 5,697,430 and 5,996,686), only a small part of the overall tube resistance is attributable to the outside of the tube. For example, a typical evaporator tube used in a flooded chiller with an enhanced outer surface but smooth inner surface typically has a 10:1 inner resistance:outer resistance ratio. Ideally, one wants to obtain an inside to outside resistance ratio of 1:1. It becomes all the more important, therefore, to develop enhancements to the inner surface of the tube that will significantly reduce the tube side resistance and improve overall heat transfer performance of the tube.

It is known to provide heat transfer tubes with alternating grooves and ridges on their inner surfaces. The grooves and ridges cooperate to enhance turbulence of fluid heat transfer mediums, such as water, delivered within the tube. This turbulence increases the fluid mixing close to the inner tube surface to reduce or virtually eliminate the boundary layer build-up of the fluid medium close to the inner surface of the tube. The boundary layer thermal resistance significantly detracts from heat transfer performance by increasing the heat transfer resistance of the tube. The grooves and ridges also provide extra surface area for additional heat exchange. This basic premise is taught in U.S. Patent No. 3,847,212 to Withers, Jr. et al.

The pattern, shapes and sizes of the grooves and ridges on the inner tube surface may be changed to further increase heat exchange performance. To that end, tube manufacturers have gone to great expense to experiment with alternative designs, including those disclosed in U.S. Patent No. 5,791,405 to Takima et al., U.S. Patent Nos. 5,332,034 and 5,458,191 to Chiang et al., and U.S. Patent No. 5,975,196 to Gaffaney et al.

In general, however, enhancing the inner surface of the tube has proven much more difficult than the outer surface. Moreover, the majority of enhancements on both the outer and inner surface of tubes are formed by molding and shaping the surfaces. Enhancements have been formed, however, by cutting the tube surfaces.

5 Japanese Patent Application 09108759 discloses a tool for centering blades that cut a continuous spiral groove directly on the inner surface of a tube. Similarly, Japanese Patent Application 10281676 discloses a tube expanding plug equipped with cutting tools that cut a continuous spiral slot and upstanding fin on the inner surface of a tube. U.S. Patent No. 3,753,364 discloses forming a continuous groove along the inner surface of a
10 tube using a cutting tool that cuts into the inner tube surface and folds the material upwardly to form the continuous groove.

While all of these inner surface tube designs aim to improve the heat transfer performance of the tube, there remains a need in the industry to continue to improve upon tube designs by modifying existing and creating new designs that enhance heat transfer
15 performance. Additionally, a need also exists to create designs and patterns that can be transferred onto the tubes more quickly and cost-effectively. As described hereinbelow, applicants have developed new geometries for heat transfer tubes as well as tools to form these geometries, and, as a result, have significantly improved heat transfer performance.

Summary of the Invention

20 This invention provides an improved heat transfer tube surface and a method of formation thereof that can be used to enhance heat transfer performance of tubes used in at least all of the above-referenced applications (i.e., flooded evaporators, falling film evaporators, spray evaporators, absorption chillers, condensers, direct expansion coolers, and single phase coolers and heaters, used in the refrigeration, chemical, petrochemical,

and food-processing industries). The inner surface of the tube is enhanced with a plurality of protrusions that significantly reduce tube side resistance and improve overall heat transfer performance. The protrusions create additional paths for fluid flow within the tube and thereby enhance turbulence of heat transfer mediums flowing within the tube. This increases fluid mixing to reduce the boundary layer build-up of the fluid medium close to the inner surface of the tube, such build-up increasing the resistance and thereby impeding heat transfer. The protrusions also provide extra surface area for additional heat exchange. Formation of the protrusions in accordance with this invention can result in the formation of up to five times more surface area along the inner surface of the tube than with simple ridges. Tests show that the performance of tubes having the protrusions of this invention is significantly enhanced.

The method of this invention includes using a tool, which can easily be added to existing manufacturing equipment, having a cutting edge to cut through ridges on the inner surface of the tube to create ridge layers and a lifting edge to lift the ridge layers to form the protrusions. In this way, the protrusions are formed without removal of metal from the inner surface of the tube, thereby eliminating debris which can damage the equipment in which the tubes are used. The protrusions on the inner surface of the tube can be formed in the same or a different operation as formation of the ridges.

Tubes formed in accordance with this application may be suitable in any number of applications, including, for example, applications for use in the HVAC, refrigeration, chemical, petrochemical, and food-processing industries. The physical geometries of the protrusions may be changed to tailor the tube to a particular application and fluid medium.

It is an object of this invention to provide improved heat transfer tubes.

It is another object of this invention to provide an improved heat transfer tube having protrusions on its inner surface.

It is yet another object of this invention to provide a method of forming an improved heat transfer tube having protrusions on its inner surface.

5 It is a further object of this invention to provide an innovative tool for forming improved heat transfer tubes.

It is a still further object of this invention to provide a tool for forming protrusions on the inner surface of heat transfer tubes.

10 These and other features, objects and advantages of this invention will become apparent by reading the following detailed description of preferred embodiments, taken in conjunction with the drawings.

Brief Description of the Drawings

FIG. 1a is a fragmentary perspective view of the partially-formed inner surface of one embodiment of a tube of this invention.

15 FIG. 1b is a side elevation view of the tube shown in FIG.1a in the direction of arrow a.

FIG. 1c is a side elevation view similar to FIG. 1b except that the protrusions protrude from the inner surface of the tube in a direction that is not perpendicular to tube axis s.

20 FIG. 1d is a front elevation view of the tube shown in FIG. 1a in the direction of arrow b.

FIG. 1e is a top plan view of the tube shown in FIG.1a.

FIG. 2 is a photomicrograph of an inner surface of one embodiment of a tube of this invention.

FIG. 3 is a photomicrograph of an inner surface of an alternative embodiment of a tube of this invention.

FIG. 4 is a side elevation view of one embodiment of the manufacturing equipment that can be used to produce tubes in accordance with this invention.

5 FIG. 5 is a perspective view of the equipment of FIG. 4.

FIG. 6a is a perspective view of one embodiment of the tool of this invention.

FIG. 6b is a side elevation view of the tool shown in FIG. 6a.

FIG. 6c is a bottom plan view of the tool of FIG. 6b.

FIG. 6d is a top plan view of the tool of FIG. 6b.

10 FIG. 7a is a perspective view of an alternative embodiment of the tool of this invention.

FIG. 7b is a side elevation view of the tool shown in FIG. 7a.

FIG. 7c is a bottom plan view of the tool of FIG. 7b.

FIG. 7d is a top plan view of the tool of FIG. 7b.

15 FIG. 8a is a fragmentary perspective view of the partially-formed inner surface of an alternative embodiment of a tube of this invention where the depth of the cut through the ridges is less than the helical ridge height.

FIG. 8b is a fragmentary perspective view of the partially-formed inner surface of an alternative embodiment of a tube of this invention where the depth of the cut through
20 the ridges is greater than the helical ridge height.

FIG. 9a is a fragmentary top plan view of the inner surface of another embodiment of a tube in accordance with this invention.

FIG. 9b is an elevation view of the tube shown in FIG. 9a in the direction of arrow
22.

FIG. 10a is a fragmentary view of an inner surface of a tube of this invention, showing the tool approaching the ridge in direction g for cutting a protrusion from the ridge in direction g.

FIG. 10b is a fragmentary view of an alternative inner surface of a tube of this invention, showing the tool approaching the ridge in direction g for cutting a protrusion from the ridge in direction g.

FIG. 11a is a schematic of the inner surface of a tube in accordance with this invention showing the angular orientation between the ridges and grooves, whereby the ridges and grooves are opposite hand helix.

FIG. 11b is a schematic of the inner surface of a tube in accordance with this invention showing the angular orientation between the ridges and grooves, whereby the ridges and grooves are same hand helix.

FIG. 12 is a bar graph comparing the tube-side heat transfer coefficients of various tubes of the prior art and of tubes in accordance with this invention.

FIG. 13 is bar graph comparing the overall heat transfer coefficients of various tubes of the prior art and of tubes in accordance with this invention.

Detailed Description of the Drawings

FIGS. 1a-e show the partially-formed inner surface 18 of one embodiment of the tube 21 of this invention. Inner surface 18 includes a plurality of protrusions 2.

Protrusions 2 are formed from ridges 1 formed on inner surface 18. Ridges 1 are first formed on inner surface 18. The ridges 1 are then cut to create ridge layers 4, which are subsequently lifted up to form protrusions 2 (best seen in FIGS. 1a and 1b). This cutting and lifting can be, but does not have to be, accomplished using tool 13, shown in FIGS. 6a-d and 7a-d and described below.

It should be understood that a tube in accordance with this invention is generally useful in, but not limited to, any application where heat needs to be transferred from one side of the tube to the other side of the tube, such as in single-phase and multi-phase (both pure liquids or gases or liquid/gas mixtures) evaporators and condensers. While the following discussion provides desirable dimensions for a tube of this invention, the tubes of this invention are in no way intended to be limited to those dimensions. Rather, the desirable geometries of the tube, including protrusions 2, will depend on many factors, not the least important of which are the properties of the fluid flowing through the tube. One skilled in the art would understand how to alter the geometry of the inner surface of the tube, including the geometry of ridges 1 and protrusion 2, to maximize the heat transfer of the tube used in various applications and with various fluids.

Ridges 1 are formed on inner surface 18 at a helix angle α to the axis s of the tube (see FIGS. 1a and 1e). Helix angle α may be any angle between 0° - 90° , but preferably does not exceed 70° . One skilled in the art will readily understand that the preferred helix angle α will often depend, at least in part, on the fluid medium used. The height e_r of ridges 1 should generally be greater the more viscous the liquid flowing through tube 21. For example, a height e_r of greater than zero (preferably, but not necessarily, at least 0.001 inches) up to 25% of the inside diameter of the tube (D_i) will generally be desirable in a tube sample used with a water/glycol mixture for low temperature applications. For purposes of this application, D_i is the inside diameter of tube 21 measured from inner surface 18 of tube 21. The axial pitch $P_{a,r}$ of ridges 1 depends on many factors, including helix angle α , the number of ridges 1 formed on inner surface 18 of tube 21, and the inside diameter D_i of tube 21. While any pitch $P_{a,r}$ may be used, the ratio of $P_{a,r}/e_r$ is preferably at least 0.002, and the ratio of e_r/D_i is preferably between approximately 0.001-

0.25. Again, however, one skilled in the art will readily understand that these preferred ratio values will often depend, at least in part, on the fluid medium used and operating conditions (e.g., the temperature of the fluid medium).

Ridge layers 4 are cut at an angle θ to axis s that is preferably between
5 approximately 20° - 50° , inclusive, and more preferably around 30° . The axial pitch $P_{a,p}$ of protrusions 2 may be any value greater than zero and generally will depend on, among other factors, the relative revolutions per minute between the tool (discussed below) and the tube during manufacture, the relative axial feed rate between the tool and the tube during manufacture, and the number of tips provided on the tool used to form the
10 protrusions during manufacture. While the resulting protrusions 2 can have any thickness S_p , the thickness S_p is preferably approximately 20-100% of pitch $P_{a,p}$. The height e_p of protrusions 2 is dependent on the cutting depth t (as seen in FIGS. 1b, 8a, and 8b) and angle θ at which the ridge layers 4 are cut. The height e_p of protrusions 2 is preferably a value at least as great as the cutting depth t up to three times the cutting depth t . It is
15 preferable, but not necessary, to form ridges 1 at a height e_r and set the cutting angle θ at a value that will result in the height e_p of protrusions 2 being at least approximately double the height e_r of ridges 1. Thus, the ratio of e_p/D_i is preferably between approximately 0.002-0.5 (i.e., e_p/D_i is double the preferred range of the ratio e_r/D_i of approximately 0.001-0.25).

20 FIGS. 1a and 1b show cutting depth t equal to the height e_r of ridges 1 so that the base 40 of protrusion 2 is located on the inner surface 18 of tube 21. The cutting depth t need not be equal to the ridge height e_r , however. Rather, the ridges 1 can be cut only partially through ridges 1 (see FIG. 8a) or beyond the height of ridges 1 and into tube wall 3 (see FIG. 8b). In FIG. 8a, the ridges 1 are not cut through their entire height e_r so that

the base 40 of protrusions 2 is positioned further from the inner surface 18 of tube 21 than the base 42 of ridges 1, which is located on the inner surface 18. In contrast, FIG. 8b illustrates a cutting depth t of beyond the ridge height e_r , so that at least one wall of the protrusions 2 extends into tube wall 3, beyond the inner surface 18 and ridge base 42.

5 When ridge layers 4 are lifted, grooves 20 are formed between adjacent protrusions 2. Ridge layers 4 are cut and lifted so that grooves 20 are oriented on inner surface 18 at an angle τ to the axis s of tube 21 (see FIGS. 1e, 11a, and 11b), which is preferably, but does not have to be, between approximately 80° - 100° .

 The shape of protrusions 2 is dependent on the shape of ridges 1 and the
10 orientation of ridges 1 relative to the direction of movement of tool 13. In the embodiment of FIGS. 1a-e, protrusions 2 have four side surfaces 25, a sloped top surface 26 (which helps decrease resistance to heat transfer), and a substantially pointed tip 28. The protrusions 2 of this invention are in no way intended to be limited to this illustrated embodiment, however, but rather can be formed in any shape. Moreover, protrusions 2 in
15 tube 21 need not all be the same shape or have the same geometry.

 Whether the orientation of protrusions 2 is straight (see FIG. 10a) or bent or
twisted (see FIG. 10b) depends on the angle β formed between ridges 1 and the direction
of movement g of tool 13. If angle β is less than 90° , protrusions 2 will have a relatively
straight orientation, such as is shown in FIG. 10a. If angle β is more than 90° , protrusions
20 2 will have a more bent and/or twisted orientation, such as, for example, is shown in FIG.
10b.

 During manufacture of tube 21, tool 13 may be used to cut through ridges 1 and lift the resulting ridge layers 4 to form protrusions 2. Other devices and methods for forming protrusions 2 may be used, however. Tool 13 can be made from any material

having the structural integrity to withstand metal cutting (e.g. steel, carbide, ceramic, etc.), but is preferably made of a carbide. The embodiments of the tool 13 shown in FIGS. 6a-d and 7a-d generally have a tool axis q , two base walls 30, 32 and one or more side walls 34. Aperture 16 is located through the tool 13. Tips 12 are formed on side walls 34 of tool 13. Note, however, that the tips can be mounted or formed on any structure that can support the tips in the desired orientation relative to the tube 21 and such structure is not limited to that disclosed in FIGS. 6a-d and 7a-d. Moreover, the tips may be retractable within their supporting structure so that the number of tips used in the cutting process can easily be varied.

FIGS. 6a-d illustrate one embodiment of tool 13 having a single tip 12. FIGS. 7a-d illustrate an alternative embodiment of tool 13 having four tips 12. One skilled in the art will understand that tool 13 may be equipped with any number of tips 12 depending on the desired pitch $P_{a,p}$ of protrusions 2. Moreover, the geometry of each tip need not be the same for tips on a single tool 13. Rather, tips 12 having different geometries to form protrusions having different shapes, orientations, and other geometries may be provided on tool 13.

Each tip 12 is formed by the intersection of planes A, B, and C. The intersection of planes A and B form cutting edge 14 that cuts through ridges 1 to form ridge layers 4. Plane B is oriented at an angle φ relative to a plane perpendicular to the tool axis q (see FIG. 6b). Angle φ is defined as $90^\circ - \theta$. Thus, angle φ is preferably between approximately 40° - 70° to allow cutting edge 14 to slice through ridges 1 at the desirable angle θ between approximately 20° - 50° .

The intersection of planes A and C form lifting edge 15 that lifts ridge layers 4 upwardly to form protrusions 2. Angle φ_i , defined by plane C and a plane perpendicular

to tool axis q , determines the angle of inclination ω (the angle between a plane perpendicular to the longitudinal axis s of tube 21 and the longitudinal axis of protrusions 2 (see FIG. 1c)) at which protrusions 2 are lifted by lifting edge 15. Angle $\varphi_1 = \text{angle } \omega$, and thus angle φ_1 on tool 13 can be adjusted to directly impact the angle of inclination ω of protrusions 2. The angle of inclination ω (and angle φ_1) is preferably the absolute value of any angle between approximately -45° to 45° relative to the plane perpendicular to the longitudinal axis s of tube 21. In this way, protrusions can be aligned with the plane perpendicular to the longitudinal axis s of tube 21 (see FIG. 1b) or incline to the left and right relative to the plane perpendicular to the longitudinal axis s of tube 21 (see FIG. 1c). Moreover, the tips 12 can be formed to have different geometries (i.e., angle φ_1 may be different on different tips), and thus the protrusions 2 within tube 21 may incline at different angles (or not at all) and in different directions relative to the plane perpendicular to the longitudinal axis s of tube 21.

While preferred ranges of values for the physical dimensions of protrusions 2 have been identified, one skilled in the art will recognize that the physical dimensions of tool 13 may be modified to impact the physical dimensions of resulting protrusions 2. For example, the depth t that cutting edge 14 cuts into ridges 1 and angle φ affect the height e_p of protrusions 2. Therefore, the height e_p of protrusions 2 may be adjusted using the expression

$$e_p = t / \sin(90 - \varphi)$$

or, given that $\varphi = 90 - \theta$,

$$e_p = t / \sin(\theta)$$

Where:

t is the cutting depth;

ϕ is the angle between plane B and a plane perpendicular to tool axis q; and

5 θ is the angle at which the ridge layers 4 are cut relative to the longitudinal axis s of the tube 21.

Thickness S_p of protrusions 2 depends on pitch $P_{a,p}$ of protrusions 2 and angle ϕ .

Therefore, thickness S_p can be adjusted using the expression

10
$$S_p = P_{a,p} \cdot \sin(90 - \phi)$$

or, given that $\phi = 90 - \theta$,

$$S_p = P_{a,p} \cdot \sin(\theta)$$

Where:

15 $P_{a,p}$ is the axial pitch of protrusions 2;

ϕ is the angle between plane B and a plane perpendicular to tool axis q; and

20 θ is the angle at which the ridge layers 4 are cut relative to the longitudinal axis s of the tube 21.

FIGS. 4 and 5 illustrate one possible manufacturing set-up for enhancing the surfaces of tube 21. These figures are in no way intended to limit the process by which tubes in accordance with this invention are manufactured, but rather any tube manufacturing process using any suitable equipment or configuration of equipment may be used. The tubes of this invention may be made from a variety of materials possessing suitable physical properties including structural integrity, malleability, and plasticity, such as, for example, copper and copper alloys, aluminum and aluminum alloys, brass, titanium, steel, and stainless steel. FIGS. 4 and 5 illustrate three arbors 10 operating on tube 21 to enhance the outer surface of tube 21. Note that one of the arbors 10 has been omitted from FIG. 4. Each arbor 10 includes a tool set-up having finning disks 7 which

30

radially extrude from one to multiple start outside fins 6 having axial pitch $P_{a,o}$. The tool set-up may include additional disks, such as notching or flattening disks, to further enhance the outer surface of tube 21. Moreover, while only three arbors 10 are shown, fewer or more arbors may be used depending on the desired outer surface enhancements.

5 Note, however, that depending on the tube application, enhancements need not be provided on the outer surface of tube 21 at all.

In one example of a way to enhance inner surface 18 of tube 21, a mandrel shaft 11 onto which mandrel 9 is rotatably mounted extends into tube 21. Tool 13 is mounted onto shaft 11 through aperture 16. Bolt 24 secures tool 13 in place. Tool 13 is preferably
10 locked in rotation with shaft 11 by any suitable means. FIGS. 6d and 7d illustrate a key groove 17 that may be provided on tool 13 to interlock with a protrusion on shaft 11 (not shown) to fix tool 13 in place relative to shaft 11.

In operation, tube 21 generally rotates as it moves through the manufacturing process. Tube wall 3 moves between mandrel 9 and finning disks 7, which exert pressure
15 on tube wall 3. Under pressure, the metal of tube wall 3 flows into the grooves between the finning disks 7 to form fins 6 on the exterior surface of tube 21.

The mirror image of a desired inner surface pattern is provided on mandrel 9 so that mandrel 9 will form inner surface 18 of tube 21 with the desired pattern as tube 21 engages mandrel 9. A desirable inner surface pattern includes ridges 1, as shown in
20 FIGS. 1a and 4. After formation of ridges 1 on inner surface 18 of tube 21, tube 21 encounters tool 13 positioned adjacent and downstream mandrel 9. As explained previously, the cutting edge(s) 14 of tool 13 cuts through ridges 1 to form ridge layers 4. Lifting edge(s) 15 of tool 13 then lift ridge layers 4 to form protrusions 2.

When protrusions 2 are formed simultaneously with outside finning and tool 13 is fixed (i.e., not rotating or moving axially), tube 21 automatically rotates and has an axial movement. In this instance, the axial pitch of protrusions $P_{a,p}$ is governed by the following formula:

$$5 \quad P_{a,p} = \frac{P_{a,o} \cdot Z_o}{Z_i}$$

Where:

$P_{a,o}$ is the axial pitch of outside fins 6;

10 Z_o is the number of fin starts on the outer diameter of tube 21;
and

Z_i is the number of tips 12 on tool 13.

15 To obtain a specific protrusion axial pitch $P_{a,p}$, tool 13 can also be rotated. Both tube 21 and tool 13 can rotate in the same direction or, alternatively, both tube 21 and tool 13 can rotate, but in opposite directions. To obtain a predetermined axial protrusion pitch $P_{a,p}$, the necessary rotation (in revolutions per minute (RPM)) of the tool 13 can be calculated using the following formula:

$$20 \quad RPM_{tool} = \frac{RPM_{tube} (P_{a,o} \cdot Z_o - P_{a,p} \cdot Z_i)}{Z_i \cdot P_{a,p}}$$

Where:

RPM_{tube} is the frequency of rotation of tube 21;

$P_{a,o}$ is the axial pitch of outer fins 6;

Z_o is the number of fin starts on the outer diameter of tube 21;

25 $P_{a,p}$ is the desirable axial pitch of protrusions 2; and

Z_i is the number of tips 12 on tool 13.

If the result of this calculation is negative, then tool 13 should rotate in the same direction of tube 21 to obtain the desired pitch $P_{a,p}$. Alternatively, if the result of this calculation is positive, then tool 13 should rotate in the opposite direction of tube 21 to obtain the desired pitch $P_{a,p}$.

5 Note that while formation of protrusions 2 is shown in the same operation as formation of ridges 1, protrusions 2 may be produced in a separate operation from finning using a tube with pre-formed inner ridges 1. This would generally require an assembly to rotate tool 13 or tube 21 and to move tool 13 or tube 21 along the tube axis. Moreover, a support is preferably provided to center tool 13 relative to the inner tube surface 18.

10 In this case, the axial pitch $P_{a,p}$ of protrusions 2 is governed by the following formula:

$$P_{a,p} = X_a / (\text{RPM} \cdot Z_i)$$

Where:

X_a is the relative axial speed between tube 21 and tool 13 (distance/time);

15 RMP is the relative frequency of rotation between tool 13 and tube 21;

$P_{a,p}$ is the desirable axial pitch of protrusions 2; and

Z_i is the number of tips 12 on tool 13.

This formula is suitable when (1) the tube moves only axially (i.e., does not rotate) and the tool only rotates (i.e., does not move axially); (2) the tube only rotates and the
20 tool moves only axially; (3) the tool rotates and moves axially but the tube is both rotationally and axially fixed; (4) the tube rotates and moves axially but the tool is both rotationally and axially fixed; and (5) any combination of the above.

With the inner tube surface of this invention, additional paths for fluid flow are created (between protrusions 2 through grooves 20) to optimize heat transfer and pressure

drop. FIG. 9a illustrates these additional paths 22 for fluid travel through tube 21. These paths 22 are in addition to fluid flow paths 23 created between ridges 1. These additional paths 22 have a helix angle α_1 relative to the tube axis s. Angle α_1 is the angle between protrusions 2 formed from adjacent ridges 1. FIG. 9b clearly shows these additional paths 22 formed between protrusions 2. Helix angle α_1 , and thus orientation of paths 22 through tube 21, can be adjusted by adjusting pitch $P_{a,p}$ of protrusions 2 using the following expression

$$P_{a,p} = \frac{P_{a,r} \cdot \tan(\alpha) \cdot \pi D_i}{\pi D_i \cdot (\tan(\alpha) + \tan(\alpha_1)) \pm P_{a,r} \cdot \tan(\alpha) \cdot \tan(\alpha_1) \cdot Z_i}$$

Where:

- 10 $P_{a,r}$ is the axial pitch of ridges 1;
 α is the angle of ridges 1 to tube axis s;
 α_1 is the desirable helix angle between protrusions 2;
 Z_i is the number of tips 12 on tool 13; and
 D_i is the inside diameter of tube 21 measured from inner surface 18 of tube
 15 21.

If ridge helix angle α and angle τ of grooves 20 are both either right hand or left hand helix (see FIG. 11b), then the "[-]" should be used in the above expression.

Alternatively, if ridge helix angle α and angle τ of grooves 20 are opposite hand helix (see FIG. 11a), then the "[+]" should be used in the above expression.

20 Tubes made in accordance with this invention outperform existing tubes. FIGS. 12 and 13 graphically illustrate the enhanced performance of two examples of such tubes (boiling tubes Tube No. 25 and Tube No. 14) by demonstrating the differences in the

enhancement factors between these tubes. The enhancement factor is the factor by which the heat transfer coefficients (both tube-side (see FIG. 12) and overall (see FIG. 13)) of these new tubes (Tube No. 25 and Tube No. 14) increase over existing tubes (Turbo-B[®], Turbo-BII[®], and Turbo B-III[®]). Again, however, Tube Nos. 25 and 14 are merely
 5 examples of tubes in accordance with this invention. Other types of tubes made in accordance with this invention outperform existing tubes in a variety of applications.

The physical characteristics of the Turbo-B[®], Turbo-BII[®], and Turbo B-III[®] tubes are described in Tables 1 and 2 of U.S. Patent No. 5,697,430 to Thors, et al. Turbo-B[®] is referenced as Tube II; Turbo-BII[®] is referenced as Tube III; and Turbo B-III[®] is
 10 referenced as Tube IV_H. The outside surfaces of Tube No. 25 and Tube No. 14 are identical to that of Turbo B-III[®]. The inside surfaces of Tube No. 25 and Tube No. 14 are in accordance with this invention and include the following physical characteristics:

Table 1. Tube and Ridge Dimensions

	Tube No. 25	Tube No. 14
15 Outside Diameter of Tube (inches)	0.750	0.750
Inside Diameter of Tube D _i (inches)	0.645	0.650
Number of Inner Ridges	85	34
Helix Angle α of Inner Ridges (degrees)	20	49
20 Inner Ridge Height e _r (inches)	0.0085	0.016
Inner Ridge Axial Pitch P _{a,r} (inches)	0.065	0.052
P _{a,r} /e _r	7.65	3.25
e _r /D _i	0.0132	0.025

25

Table 2. Protrusion Dimensions

	Tube No. 25	Tube No. 14
Protrusion Height e_p (inches)	0.014	0.030
Protrusion Axial Pitch $P_{a,p}$ (inches)	0.0167	0.0144
Protrusion Thickness S_p (inches)	0.0083	0.007
Depth of Cut into Ridge t (inches)	0.007	0.015

Moreover, the tool used to form the protrusions on Tube Nos. 25 and 14 had the following characteristics:

Table 3. Tool Dimensions

	Tube No. 25	Tube No. 14
Number of Cutting Tips Z_i	3	1
Angle ϕ (degrees)	60°	60°
Angle ω (degrees)	2°	2°
Angle τ (degrees)	89.5°	89.6°
Angle β (degrees)	69.5°	40.6°
Number of Outside Diameter Fin Starts	3	N/A
Tool Revolution per Minute	0	1014
Tube Revolution per Minute	1924	0
X_a (inches/minute)	96.2	14.7

FIG. 12 shows that the tube-side heat transfer coefficient of Tube No. 14 is approximately 1.8 times and Tube No. 25 is approximately 1.3 times that of Turbo B-III[®], which is currently the most popular tube used in evaporator applications and shown as a

baseline in FIGS. 12 and 13. Similarly, FIG. 13 shows that the overall heat transfer coefficient of Tube No. 25 is approximately 1.25 times and Tube No. 14 is approximately 1.5 times that of Turbo B-III[®].

The foregoing is provided for purposes of illustrating, explaining, and describing
5 embodiments of this invention. Further modifications and adaptations to these
embodiments will be apparent to those skilled in the art and may be made without
departing from the scope or spirit of the invention.

We claim:

1. A tube comprising an inner surface, an outer surface, and a longitudinal axis, wherein the inner surface comprises at least one protrusion cut at a cutting depth from a ridge formed along the inner surface of the tube.
5
2. The tube of claim 1, wherein the ridge is formed along the inner surface at a ridge angle relative to the longitudinal axis between approximately 0° and 90°.
3. The tube of claim 2, wherein the angle is preferably no more than 70°.
- 10 4. The tube of claim 1, wherein the tube has an inside diameter and the ridge has a height of no more than 25% of the inside diameter.
5. The tube of claim 1, wherein the ridge has a height of at least 0.001 inches.
- 15 6. The tube of claim 1, wherein the tube has an inside diameter and the ridge has a height, wherein the ratio of the ridge height to inside diameter is at least 0.001.
7. The tube of claim 1, further comprising a plurality of ridges, wherein the ridges
20 have an axial pitch and a height and the ratio of the ridge axial pitch to ridge height is at least 0.002.
8. The tube of claim 1, wherein the at least one protrusion has a height that is a value no more than three times the cutting depth.
- 25 9. The tube of claim 8, wherein the at least one protrusion has a height that is a value at least as great as the cutting depth.
10. The tube of claim 1, wherein the tube has an inside diameter and the at least one
30 protrusion has a height, wherein the ratio of the protrusion height to tube inside diameter is between approximately 0.002 and 0.5.
11. The tube of claim 1, wherein the at least one protrusion comprises at least three side surfaces and a top surface.

12. The tube of claim 11, wherein the top surface is sloped.
13. The tube of claim 1, wherein the at least one protrusion has a substantially pointed
5 tip.
14. The tube of claim 1, wherein the at least one protrusion extends from the inner surface in a direction substantially perpendicular to the longitudinal axis.
- 10 15. The tube of claim 1, wherein the at least one protrusion protrudes from the inner surface in a direction that is not substantially perpendicular to the longitudinal axis.
16. The tube of claim 1, wherein the at least one protrusion comprises a plurality of protrusions, at least one of the plurality of protrusions extending from the inner surface in
15 a direction substantially perpendicular to the longitudinal axis and at least one of the plurality of protrusions extending from the inner surface in a direction that is not substantially perpendicular to the longitudinal axis.
17. The tube of claim 1, wherein the ridge comprises a ridge base and the at least one
20 protrusion comprises at least one wall that extends into the inner surface of the tube beyond the ridge base.
18. The tube of claim 1, wherein the at least one protrusion comprises a protrusion base located on the inner surface of the tube.
- 25 19. The tube of claim 1, wherein the ridge comprises a ridge base and the at least one protrusion comprises a protrusion base, wherein the protrusion base is located a distance further from the inner surface of the tube than the ridge base.
- 30 20. The tube of claim 1, wherein the at least one protrusion comprises a plurality of protrusions and the tube further comprises grooves formed between the plurality of protrusions at an angle between approximately 80° and 100° relative to the longitudinal axis of the tube.

21. The tube of claim 1, wherein the at least one protrusion comprises a plurality of protrusions having a pitch and each protrusion having a thickness, wherein the protrusion thickness is between approximately 20% and 100% of the protrusion pitch.
- 5 22. A tool for cutting the inner surface of a tube comprising a tool axis and at least one tip formed by the intersection of at least a first plane, a second plane, and a third plane and having a cutting edge and a lifting edge.
- 10 23. The tool of claim 22, wherein the tool comprises at least one of carbide, steel, and ceramic.
24. The tool of claim 22, wherein the cutting edge is formed by the intersection of the first plane and the second plane.
- 15 25. The tool of claim 24, wherein the second plane is oriented at an angle between approximately 40° and 70° relative to a plane perpendicular to the tool axis.
- 20 26. The tool of claim 22, wherein the lifting edge is formed by the intersection of the first plane and the third plane.
27. The tool of claim 26, wherein the third plane is oriented at an angle relative to a plane perpendicular to the tool axis.
28. The tool of claim 27, wherein the angle is zero.
- 25 29. The tool of claim 27, wherein the angle is not zero.
30. The tool of claim 29, wherein the angle is no more than approximately 45°.
- 30 31. The tool of claim 22, wherein the at least one tip comprises more than one tip.
32. The tool of claim 25, wherein the at least one tip comprises at least two tips and the angle of the second plane relative to the plane perpendicular to the tool axis of at least two of the at least two tips is not equal.

33. The tool of claim 27, wherein the at least one tip comprises at least two tips and the angle of the third plane relative to the plane perpendicular to the tool axis of at least two of the at least two tips is not equal.

5

34. A method of manufacturing a tube having a longitudinal axis comprising:
a. cutting through at least one ridge formed along an inner surface of the tube to a cutting depth and at an angle relative to the longitudinal axis to form ridge layers; and
b. lifting the ridge layers to form protrusions having a protrusion height,
10 protrusion thickness, and protrusion pitch.

35. The method of claim 34, wherein the at least one ridge is cut through at an angle between approximately 20° and 50° relative to the longitudinal axis of the tube.

15 36. The method of claim 35, wherein the at least one ridge is cut through at an angle approximately 30° relative to the longitudinal axis of the tube.

37. The method of claim 34, wherein the at least one ridge has a ridge height and the cutting depth approximately equals the ridge height.

20

38. The method of claim 34, wherein the at least one ridge has a ridge height and the cutting depth is less than the ridge height.

25 39. The method of claim 34, wherein the at least one ridge has a ridge height and the cutting depth is greater than the ridge height.

40. The method of claim 34, wherein lifting the ridge layers to form protrusions comprises lifting the ridge layers so that at least one of the protrusions extends from the inner surface in a direction substantially perpendicular to the longitudinal axis.

30

41. The method of claim 34, wherein lifting the ridge layers to form protrusions comprises lifting the ridge layers so that at least one of the protrusions extends from the inner surface in a direction that is not substantially perpendicular to the longitudinal axis.

42. The method of claim 34, wherein lifting the ridge layers to form protrusions comprises lifting the ridge layers so that at least one of the protrusions extends from the inner surface in a direction substantially perpendicular to the longitudinal axis and at least one of the protrusions extends from the inner surface in a direction that is not substantially perpendicular to the longitudinal axis.
43. The method of claim 34, further comprising forming the at least one ridge on the inner surface of the tube.
44. The method of claim 43, wherein the ridge is formed along the inner surface at an angle between approximately 0° and 90° relative to the longitudinal axis of the tube.
45. The method of claim 34, further comprising forming fins on an outer surface of the tube.
46. The method of claim 34, wherein the cutting and lifting is performed using a tool comprising a tool axis and at least one tip formed by the intersection of at least a first plane, a second plane, and a third plane and having a cutting edge and a lifting edge.
47. The method of claim 46, wherein the cutting edge is formed by the intersection of the first plane and the second plane.
48. The tool of claim 47, wherein the second plane is oriented at an angle between approximately 40° and 70° relative to a plane perpendicular to the tool axis.
49. The method of claim 46, wherein the lifting edge is formed by the intersection of the first plane and the third plane.
50. The method of claim 49, wherein the third plane is oriented at an angle relative to a plane perpendicular to the tool axis and the protrusions are oriented at an angle relative to a plane perpendicular to the longitudinal axis of the tube.
51. The method of claim 50, wherein the angle of the third plane is approximately equal to the angle of the protrusions.

52. The method of claim 50, wherein the angle of the third plane and the angle of the protrusions are no more than 45°.

53. The method of claim 46, further comprising predetermining the protrusion height
5 (e_p) using $e_p = t / \sin(90 - \varphi)$ or $e_p = t / \sin(\theta)$, where:

t is the cutting depth;

10 φ is the angle between the second plane and a plane perpendicular to the tool axis; and

θ is the angle through which the at least one ridge layer is cut relative to the longitudinal axis of the tube.

15 54. The method of claim 46, further comprising predetermining the protrusion thickness (S_p) using $S_p = P_{a,p} \cdot \sin(90^\circ - \varphi)$ or $S_p = P_{a,p} \cdot \sin(\theta)$, where:

$P_{a,p}$ is the protrusion pitch;

20 φ is the angle between the second plane and a plane perpendicular to the tool axis; and

θ is the angle through which the at least one ridge layer is cut relative to the longitudinal axis of the tube.

25 55. A method of enhancing the inner surface of a tube, comprising:

a. mounting a tool onto a shaft, the tool comprising a tool axis and at least one tip formed by the intersection of at least a first plane, a second plane, and a third plane and having a cutting edge and a lifting edge;

b. positioning the tool in the tube;

30 c. causing relative rotation and relative axial movement between the tube and the tool to cut at least partially though at least one ridge formed along the surface of the tube to form ridge layers and lift the ridge layers to form protrusions.

56. The method of claim 55, wherein the tube rotates and moves axially and the tool
35 neither rotates nor moves axially.

57. The method of claim 55, wherein the tool rotates and moves axially and the tube neither rotates nor moves axially.
58. The method of claim 55, wherein the tube rotates in a direction and the tool rotates
5 in the direction of the tube.
59. The method of claim 55, wherein the tube rotates in a direction and the tool rotates in a direction opposite the rotational direction of the tube.
- 10 60. The method of claim 55, wherein the tube moves axially and the tool rotates.
61. The method of claim 55, wherein the tube rotates and the tool moves axially.
62. The method of claim 55, further comprising mounting a mandrel on the shaft to
15 form the at least one ridge on the inner surface of the tube.
63. The method of claim 55, further comprising rotating the shaft, wherein the tool further comprises a locking means to lock the tool in rotation with the shaft.
- 20 64. The method of claim 63, wherein the locking means comprises a groove and the shaft comprises a protrusion that mates with the groove.
65. An evaporator comprising at least one tube of claim 1.
- 25 66. A condenser comprising at least one tube of claim 1.
67. A heat exchanger comprising at least one tube of claim 1.

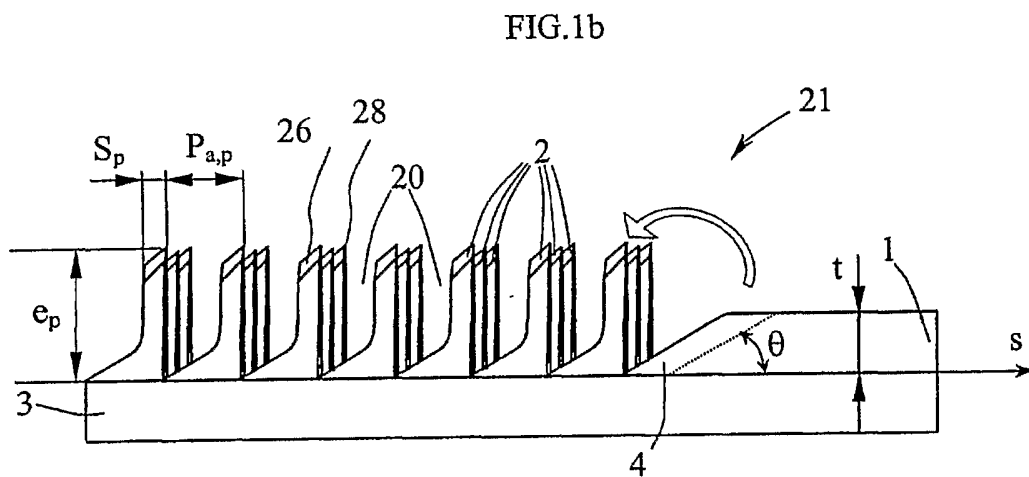
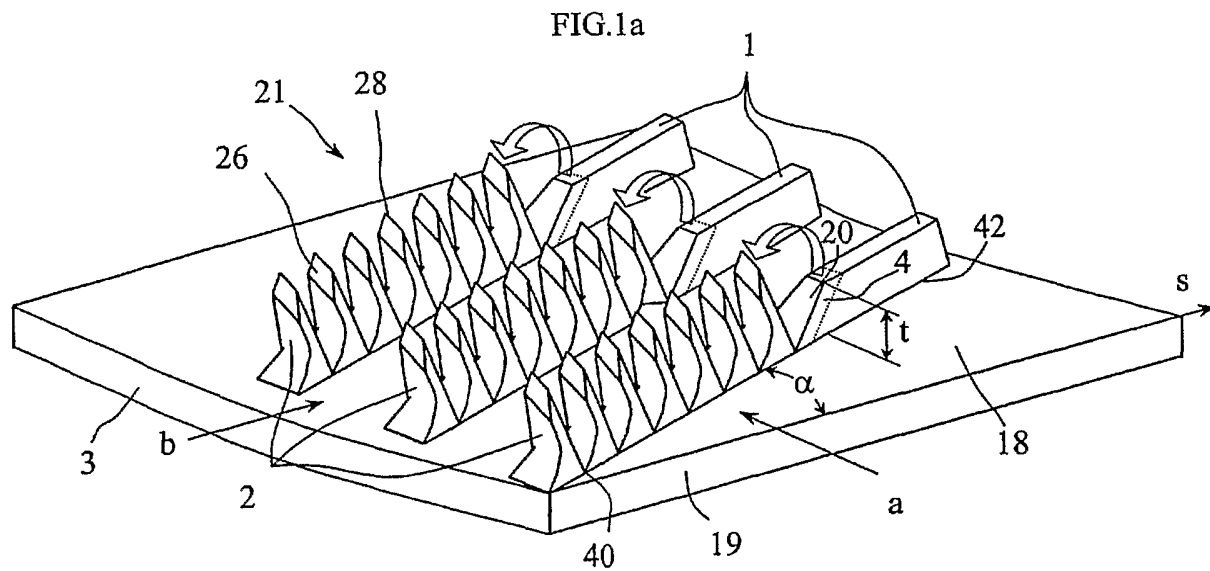

2/12
FIG.1c

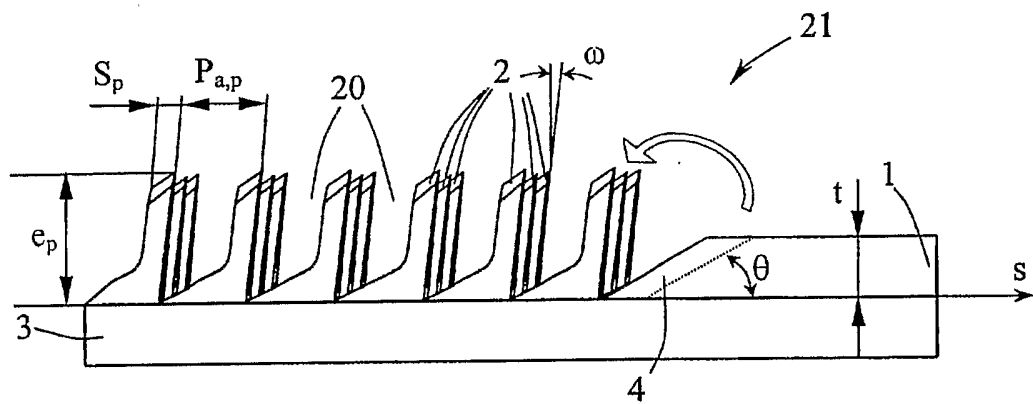
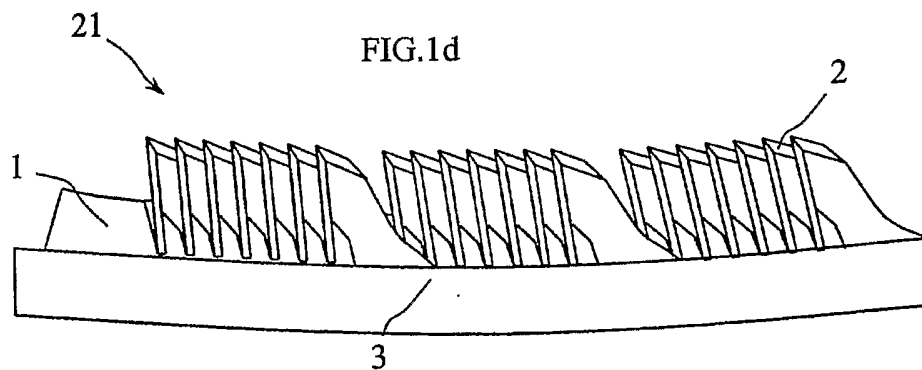
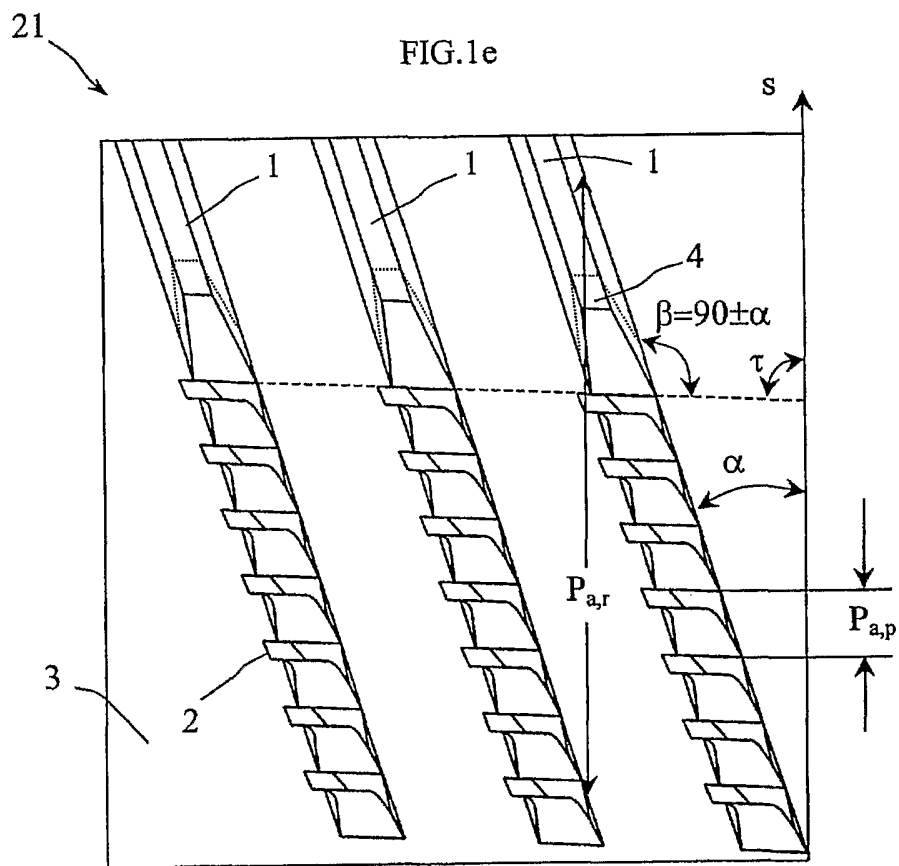

FIG.1d



3/12

FIG.1e



4/12

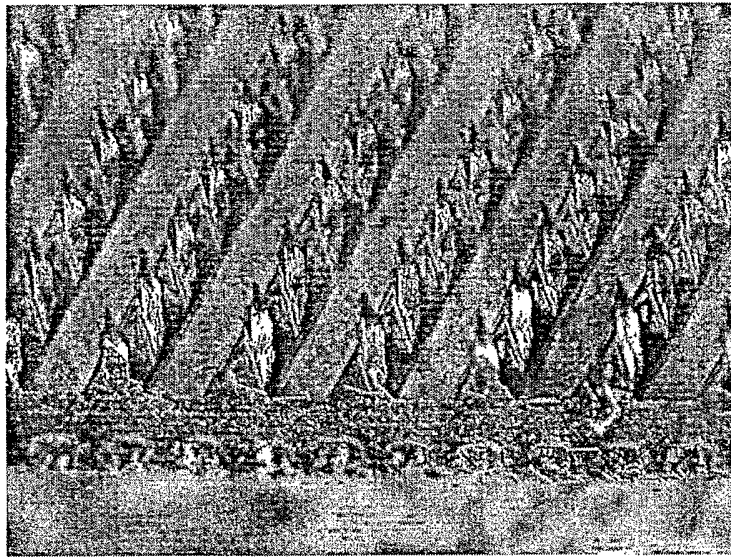

FIG.2

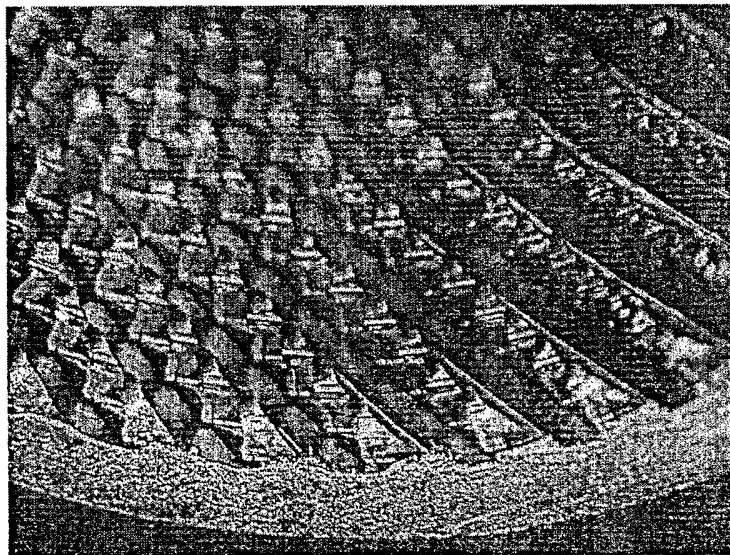

FIG.3

FIG.4

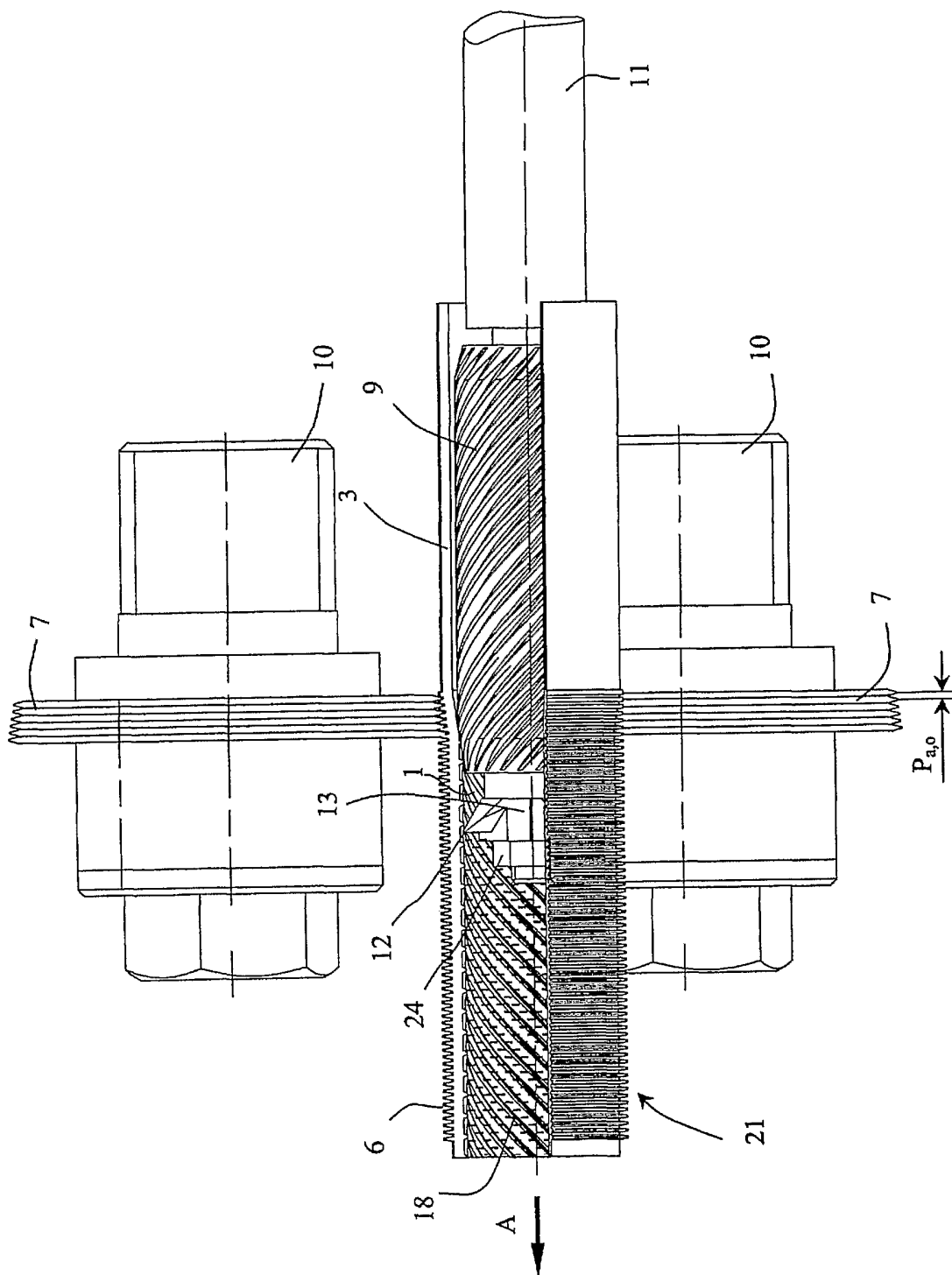
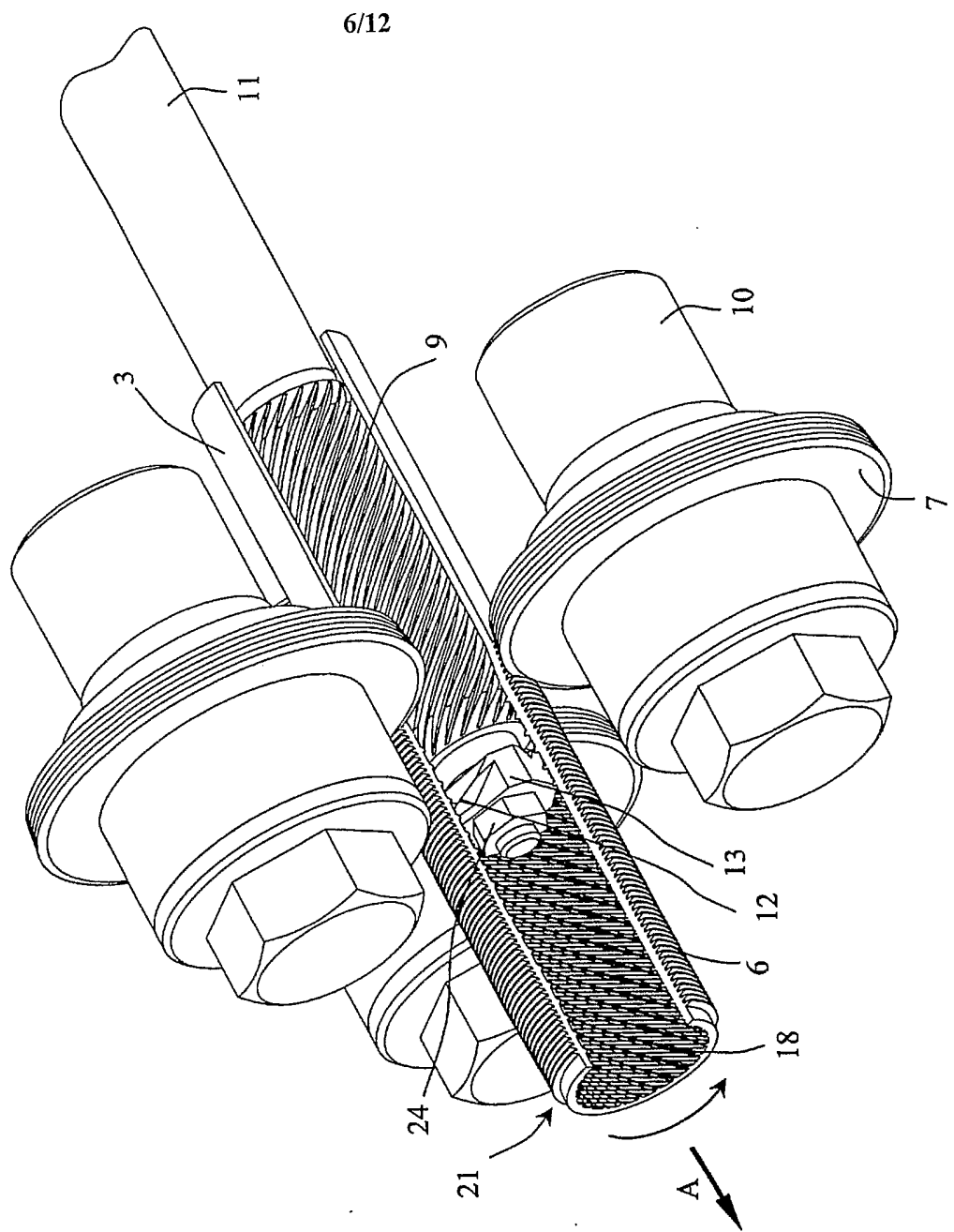

FIG.5



7/12
FIG.6a

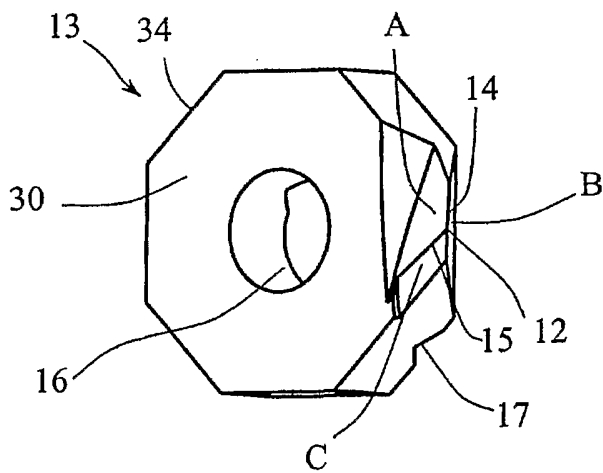

FIG.6b

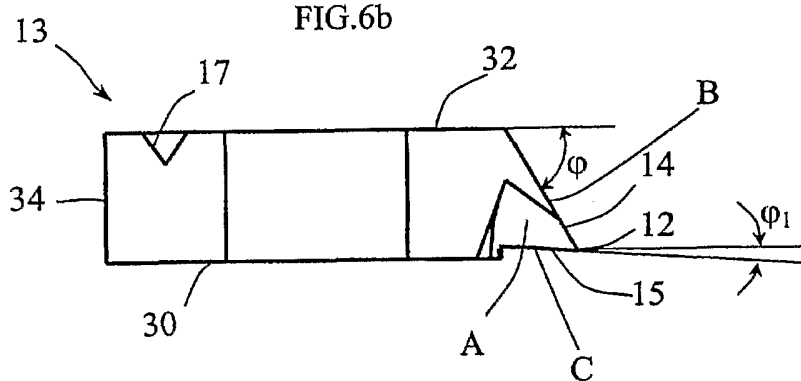

FIG.6c

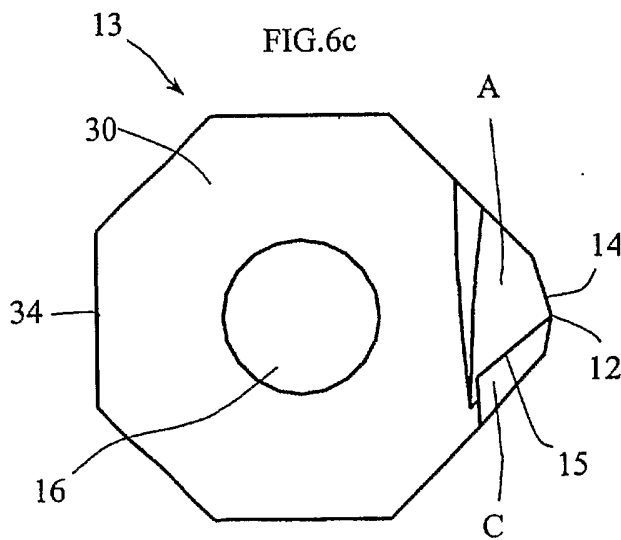
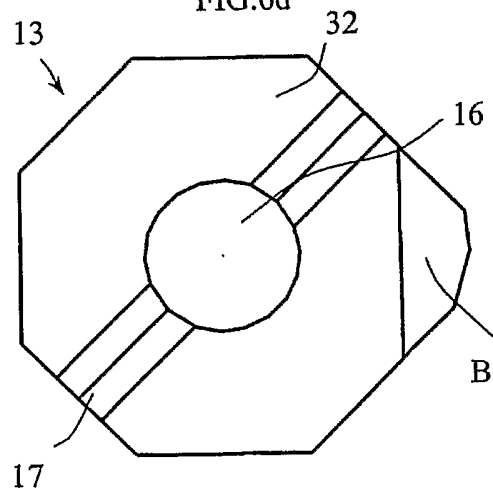

FIG.6d



8/12 FIG.7a

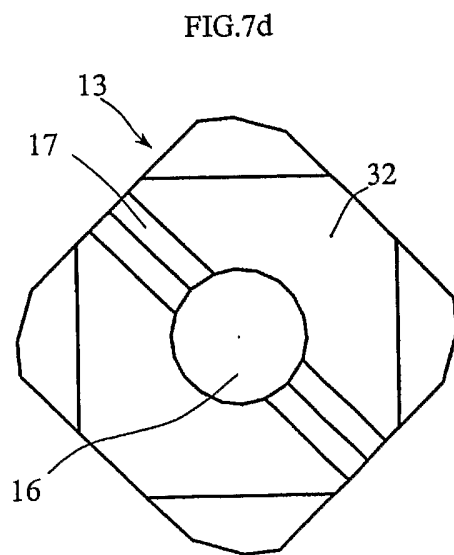
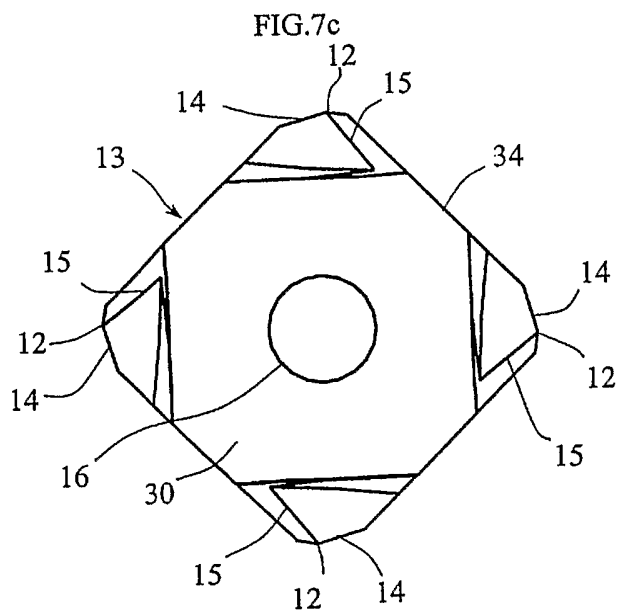
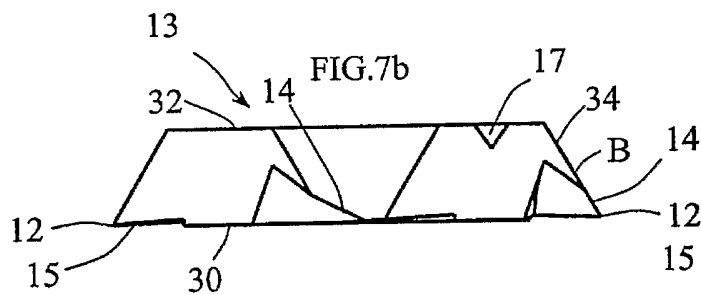
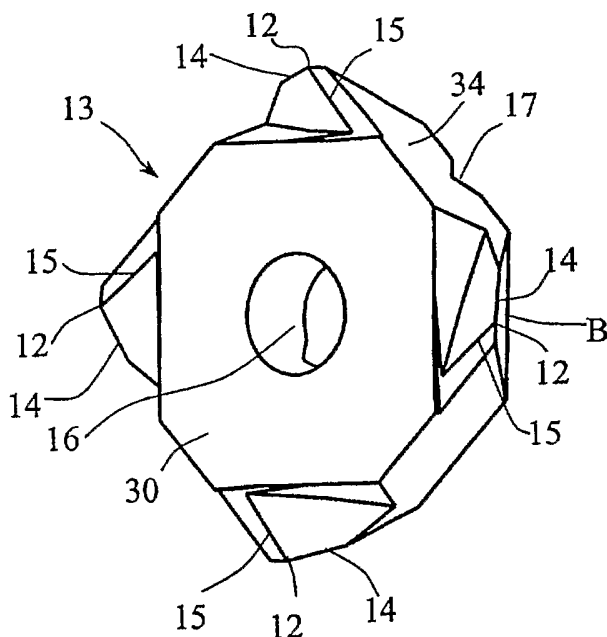

Fig.8a

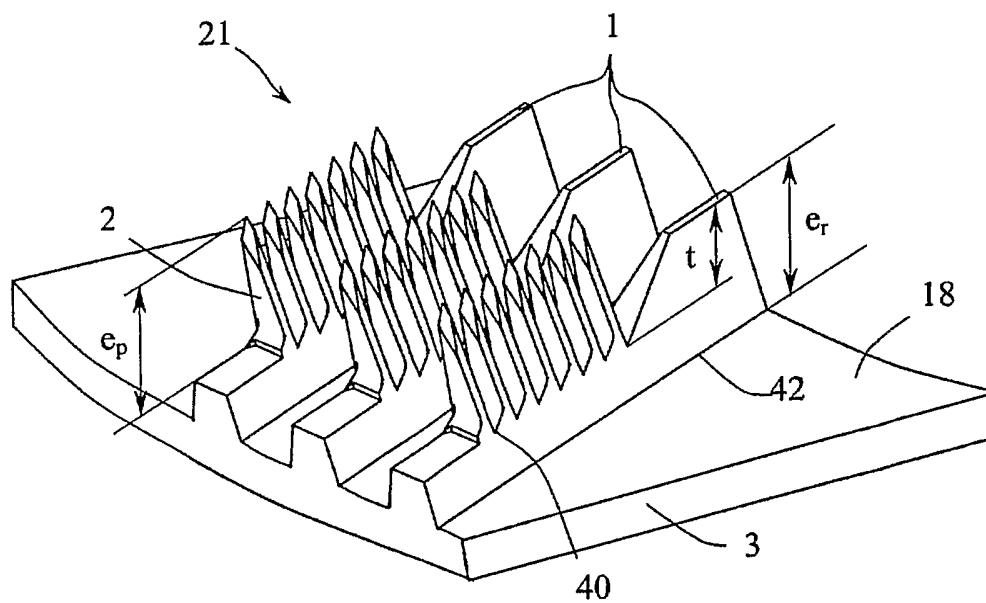

FIG. 8b

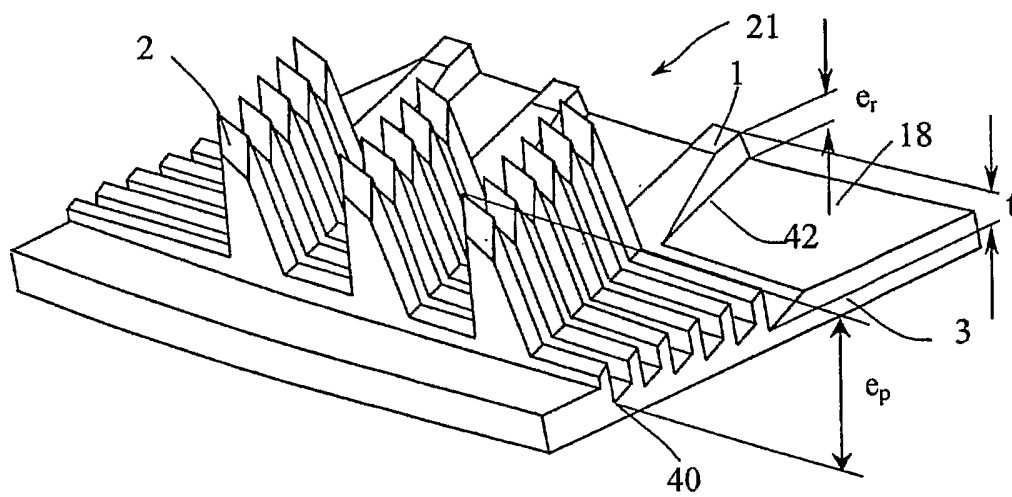

FIG.9a

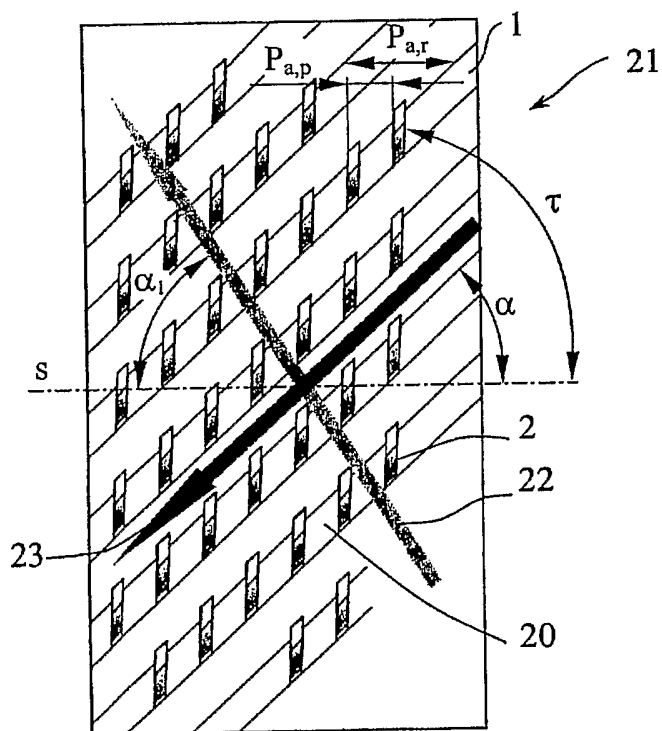

FIG.9b

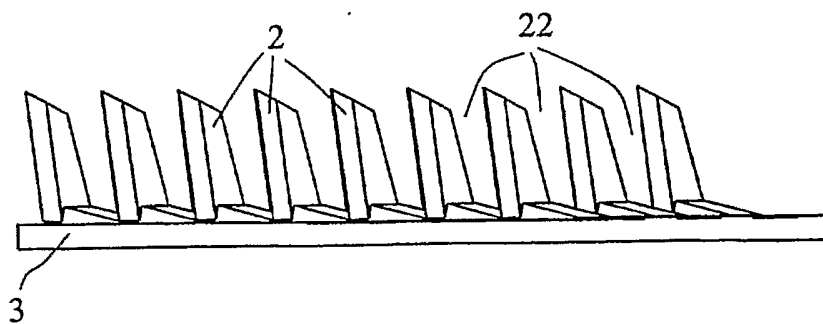

FIG.10a

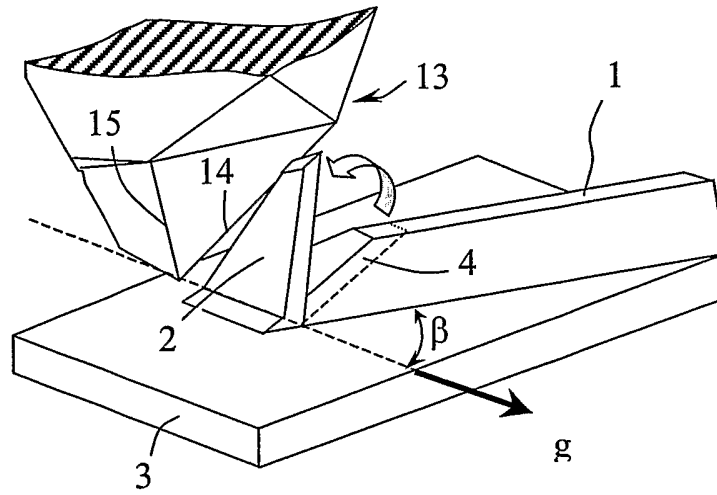
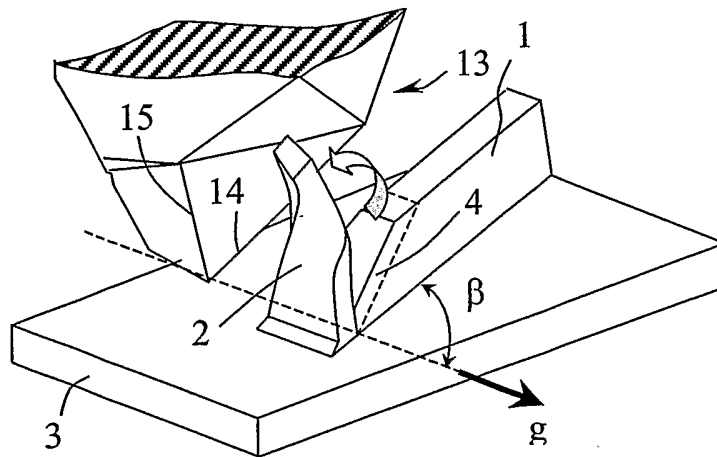
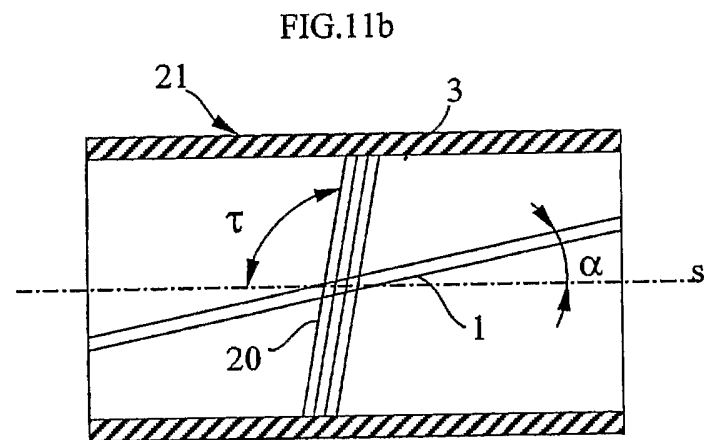
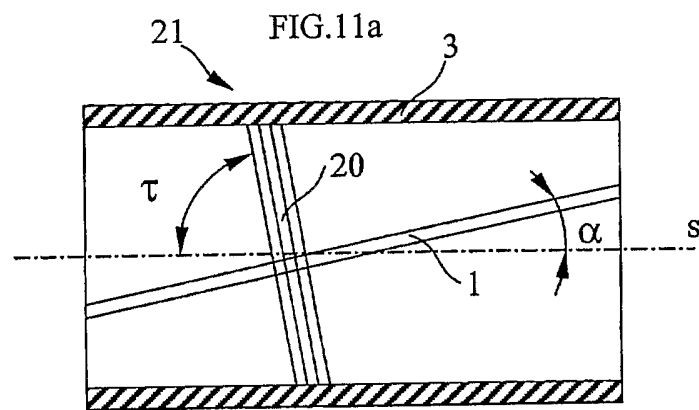

FIG.10 b





INTERNATIONAL SEARCH REPORT

International Application No

PCT/US 03/18304

A. CLASSIFICATION OF SUBJECT MATTER
 IPC 7 F28F1/42 B21C37/20

According to International Patent Classification (IPC) or to both national classification and IPC

B. FIELDS SEARCHED

Minimum documentation searched (classification system followed by classification symbols)

IPC 7 F28F B21C

Documentation searched other than minimum documentation to the extent that such documents are included in the fields searched

Electronic data base consulted during the international search (name of data base and, where practical, search terms used)

EPO-Internal, PAJ

C. DOCUMENTS CONSIDERED TO BE RELEVANT

Category °	Citation of document, with indication, where appropriate, of the relevant passages	Relevant to claim No.
X	US 6 026 892 A (KIM PYUNG GON ET AL) 22 February 2000 (2000-02-22) column 4, line 20 -column 6, line 2; figures	1-11, 14, 18-21
X	PATENT ABSTRACTS OF JAPAN vol. 012, no. 109 (M-682), 8 April 1988 (1988-04-08) -& JP 62 237295 A (KOBE STEEL LTD), 17 October 1987 (1987-10-17)	1, 2, 13, 14, 19
A	abstract; figures	22, 34, 55
X	PATENT ABSTRACTS OF JAPAN vol. 1998, no. 12, 31 October 1998 (1998-10-31) -& JP 10 197184 A (HITACHI LTD), 31 July 1998 (1998-07-31)	1, 11, 14, 19
A	abstract; figures	22, 34, 55
	-/--	

Further documents are listed in the continuation of box C.

Patent family members are listed in annex.

° Special categories of cited documents :

- *A* document defining the general state of the art which is not considered to be of particular relevance
- *E* earlier document but published on or after the international filing date
- *L* document which may throw doubts on priority claim(s) or which is cited to establish the publication date of another citation or other special reason (as specified)
- *O* document referring to an oral disclosure, use, exhibition or other means
- *P* document published prior to the international filing date but later than the priority date claimed

- *T* later document published after the international filing date or priority date and not in conflict with the application but cited to understand the principle or theory underlying the invention
- *X* document of particular relevance; the claimed invention cannot be considered novel or cannot be considered to involve an inventive step when the document is taken alone
- *Y* document of particular relevance; the claimed invention cannot be considered to involve an inventive step when the document is combined with one or more other such documents, such combination being obvious to a person skilled in the art.
- *&* document member of the same patent family

Date of the actual completion of the international search

10 October 2003

Date of mailing of the international search report

16/10/2003

Name and mailing address of the ISA

European Patent Office, P.B. 5818 Patentlaan 2
 NL - 2280 HV Rijswijk
 Tel. (+31-70) 340-2040, Tx. 31 651 epo nl,
 Fax: (+31-70) 340-3016

Authorized officer

Mootz, F

INTERNATIONAL SEARCH REPORT

International Application No

PCT/US 03/18304

C.(Continuation) DOCUMENTS CONSIDERED TO BE RELEVANT

Category °	Citation of document, with indication, where appropriate, of the relevant passages	Relevant to claim No.
A	EP 0 865 838 A (CARRIER CORP) 23 September 1998 (1998-09-23) claims; figures ----	1-56
A	US 3 202 212 A (KRITZER RICHARD W) 24 August 1965 (1965-08-24) the whole document ----	1-21
A	FR 2 268 580 A (Q DOT CORP) 21 November 1975 (1975-11-21) page 2, line 16 -page 5, line 33; figures -----	1, 22, 34, 55

INTERNATIONAL SEARCH REPORT
on patent family members

International Application No
PCT/US 03/18304

Patent document cited in search report		Publication date	Patent family member(s)	Publication date
US 6026892	A	22-02-2000	KR 245383 B1	02-03-2000
			JP 3049692 B2	05-06-2000
			JP 10103887 A	24-04-1998

JP 62237295	A	17-10-1987	NONE	

JP 10197184	A	31-07-1998	JP 3331518 B2	07-10-2002

EP 0865838	A	23-09-1998	US 5933953 A	10-08-1999
			AU 722999 B2	17-08-2000
			AU 5842698 A	17-09-1998
			CA 2230213 C	06-05-2003
			CN 1193722 A	23-09-1998
			EP 0865838 A1	23-09-1998
			ES 2174408 T3	01-11-2002
			JP 2945649 B2	06-09-1999
			JP 10263734 A	06-10-1998

US 3202212	A	24-08-1965	NONE	

FR 2268580	A	21-11-1975	FR 2268580 A1	21-11-1975
