

No. 606,733.

Patented July 5, 1898.

A. G. NOACK & L. S. GROSSMAN.
HYDRAULIC AIR COMPRESSOR.

(No Model.)

(Application filed Dec. 24, 1896.)

2 Sheets—Sheet 1.

-FIG. I-

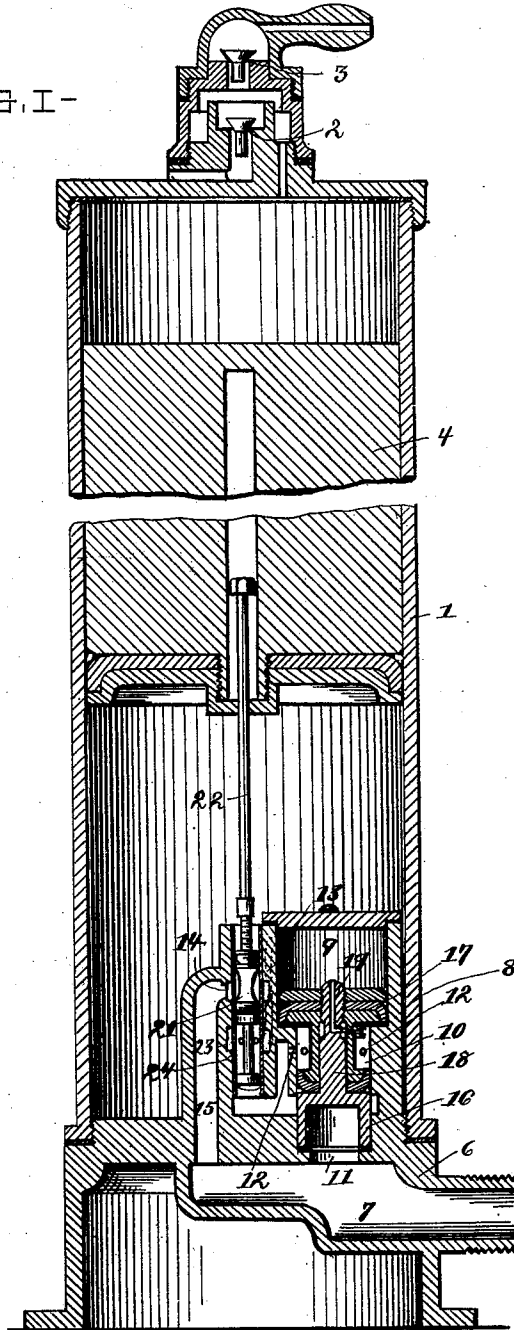

WITNESSES:

Philip E. Knowlton
C. L. Stocker

INVENTORS:

A. G. Noack & L. S. Grossman,
BY
H. M. Fecher
ATTORNEY.

No. 606,733.

Patented July 5, 1898.

A. G. NOACK & L. S. GROSSMAN.
HYDRAULIC AIR COMPRESSOR.

(No Model.)

(Application filed Dec. 24, 1896.)

2 Sheets—Sheet 2.

- FIG. II -

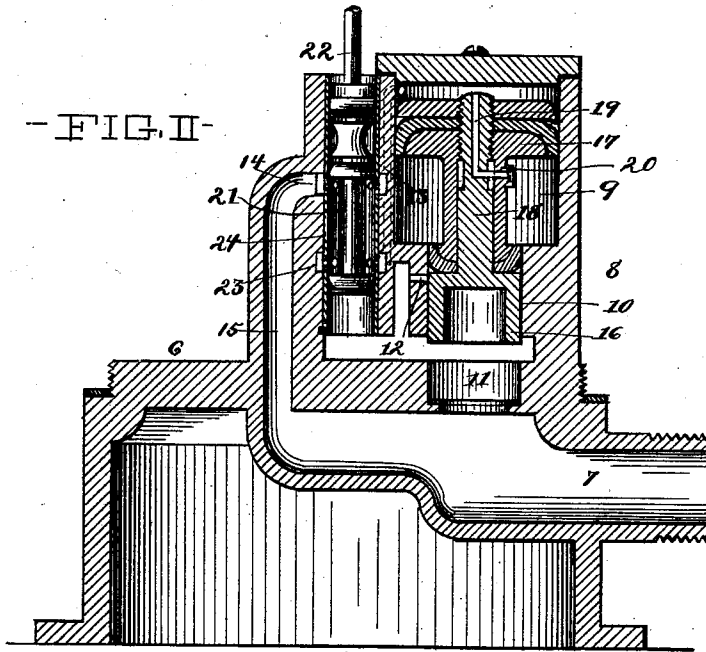

- FIG. III -

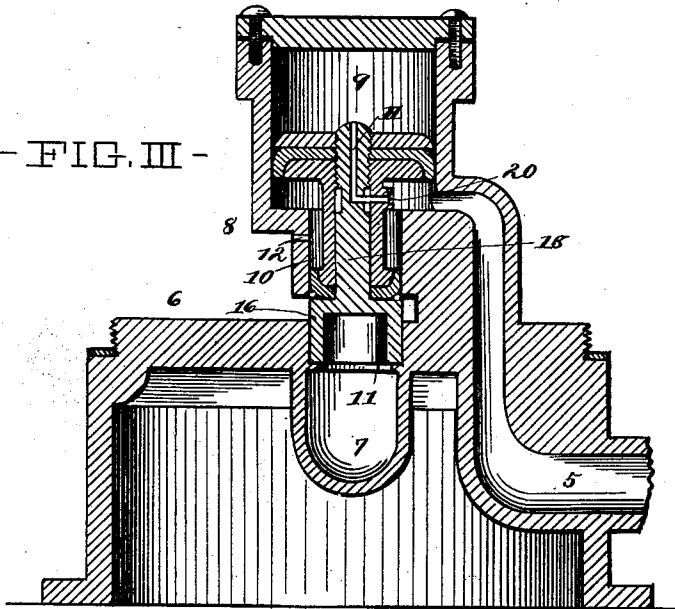

WITNESSES:

Philip E. Knowlton
C. L. Stocker

INVENTORS:

A. G. Noack & L. S. Grossman,

BY

H. J. Lecher
ATTORNEY.

UNITED STATES PATENT OFFICE.

ADOLPH G. NOACK AND LORENZ S. GROSSMAN, OF CLEVELAND, OHIO, ASSIGNORS, BY MESNE ASSIGNMENTS, TO CLEMENT L. V. EVANS, TRUSTEE, OF THE BERNER-MAYER COMPANY, OF SAME PLACE.

HYDRAULIC AIR-COMPRESSOR.

SPECIFICATION forming part of Letters Patent No. 606,733, dated July 5, 1898.

Application filed December 24, 1896. Serial No. 616,840. (No model.)

To all whom it may concern:

Be it known that we, ADOLPH G. NOACK and LORENZ S. GROSSMAN, citizens of the United States, and residents of Cleveland, county of Cuyahoga, and State of Ohio, have invented certain new and useful Improvements in Hydraulic Air-Compressors, of which the following is a specification, the principle of the invention being herein explained and the best mode in which we have contemplated applying that principle, so as to distinguish it from other inventions.

The annexed drawings and the following description set forth in detail one mechanical form embodying the invention, such detail construction being but one of various mechanical forms in which the principle of the invention may be used.

In said annexed drawings, Figure I represents an axial section of our improved air-compressor, the valves being illustrated as in position to admit water into the cylinder and the piston being illustrated as near the upper end of its upstroke; Fig. II, an axial section of the valve mechanism, illustrating the valves in position to exhaust water from the cylinder; and Fig. III, a section taken at right angles to the sections illustrated in Figs. I and II of the valve mechanism and illustrating the main controlling-valve in position to admit water into the lower end of the cylinder.

The air-compressor has a cylinder 1, the top of which has an air-inlet valve 2 and an air-outlet valve 3 and has a weighted piston 4, fitted to reciprocate within it. A water-inlet 5 enters through the base 6 of the compressor and a water-outlet 7 is provided through the base. A main controlling-valve casing 8 is provided at the bottom of the air and water cylinder, being preferably formed upon the base of the cylinder, and said casing has a large actuating-piston chamber 9 at its upper end and a small main controlling-valve chamber 10 at its lower end. The two chambers are axially aligned and open one into the other. The lower open end of the valve-chamber registers with and is placed a slight distance above a water-outlet port 11, and the water-inlet passage enters the casing at the jun-

tion between the piston-chamber and the valve-chamber. The valve-chamber has a circumferential row of perforations 12, which form a port through which the inlet-water may enter the lower end of the cylinder. Water may waste out of the bottom of the cylinder through the opening and port formed below the end of the valve-chamber. The upper end of the actuating-piston chamber communicates with an annular port 23 in a primary-valve chamber 24 through a passage 13. An annular port 14 is formed above said last-mentioned port in the primary-valve chamber, and said port 14 communicates with the water-outlet through a passage 15. A cylindrical main controlling-valve 16 has play in the valve-chamber and may have seat upon the water-outlet port, when the valve will also close the opening at the lower end of the valve-chamber. The valve is connected to an actuating-piston 17, which reciprocates in the piston-chamber by means of a stem 18, which stem is formed with a bore 19, extending through the piston and through a strainer-nipple 20 in the side of the stem. Said bore thus furnishes constant communication between the inlet-water against the under side of the actuating-piston and the space above said piston; but said bore is of less diameter and capacity than the passage between the piston-chamber and the primary-valve chamber, so that water may more quickly be emptied out of the upper end of the piston-chamber than it can enter through the bore of the piston. The ends of the primary-valve chamber are open to the interior of the air and water cylinder, and a three-piston valve 21 slides in said primary-valve chamber. The upper and lower pistons of this valve are simply packings, and the middle piston of the valve cuts off or opens communication between the port 23 and port 14 when the primary valve is depressed or raised. A rod 22 forms a slip-joint connection between the weighted piston in the air and water cylinder and the primary valve, and said rod has stops at its upper and lower end, so that the valve may be raised or lowered as the piston arrives at the upper or lower end of its stroke.

In practice, when the valves are in the posi-

tions illustrated in Fig. I the main controlling-valve closes the outlet and has uncovered the distributing-port into the cylinder, so that the inlet-water can pass into the cylinder and force the weighted piston upward. The primary valve is in such position that exhaust from the upper end of the piston-chamber is closed off, and the feed-water passing from the inlet through the strainer-nipple and the bore of the stem will equalize the pressure from below against the piston and will admit of the pressure from above against the valve, forcing the latter and the piston down. When the weighted piston arrives to the uppermost end of its stroke, the stop upon the upper end of the valve-rod will be engaged and the rod and valve will be raised. This shifting of the primary valve will make communication to the waste from the upper end of the piston-chamber, so that the excess pressure from below will raise the piston and valve and will uncover the outlet-port and cut communication between the water-inlet and the distributing-port. The water in the cylinder beneath the weighted piston will waste out through the outlet-port and passage and the weighted piston will be lowered. The up-stroke of the piston compresses air and forces it out through the air-outlet valve and nipple, and the downward stroke of the weighted piston will draw in air through the air-inlet valve and again fill the cylinder above the weighted piston. As the ends of the primary-valve chamber are open to the interior of the cylinder the primary valve is at all times balanced and will remain in the position given to it by the ascending or descending weighted piston.

Other modes of applying the principle of our invention may be employed for the mode

herein explained. Change may therefore be made as regards the mechanism thus disclosed, provided the principles of construction set forth respectively in the following claim are employed.

We therefore particularly point out and distinctly claim as our invention—

In a hydraulic air-compressor, the combination of an air-and-water chamber having air inlet and outlet at its top and water inlet and outlet at its bottom, a main controlling-valve controlling the water inlet and outlet for the chamber and having an actuating-piston connected to it by a stem formed with a water-passage through it and the top of the piston, a piston-chamber for said piston and having inlet for the actuating-water at one end and a water-outlet at the other end, a primary-valve chamber open at both ends and having a waste-port near its upper end and a port near its lower end communicating with the outlet from the actuating-piston chamber, and a primary valve having means for raising it and lowering it at the extreme upper and lower water-level in the air-and-water chamber and provided with a packing-piston at its upper end, a distributing-piston playing at both sides of the waste-port, and a packing-piston at its lower end permanently below the port communicating with the outlet from the actuating-piston chamber, substantially as set forth.

In testimony that we claim the foregoing to be our invention we have hereunto set our hands this 12th day of October, A. D. 1896.

ADOLPH G. NOACK.
LORENZ S. GROSSMAN.

Witnesses:

WM. SECHER,
E. I. BROWN.