

(No Model.)

2 Sheets—Sheet 1.

S. ROEBUCK.
WINDOW SCREEN.

No. 416,806.

Patented Dec. 10, 1889.

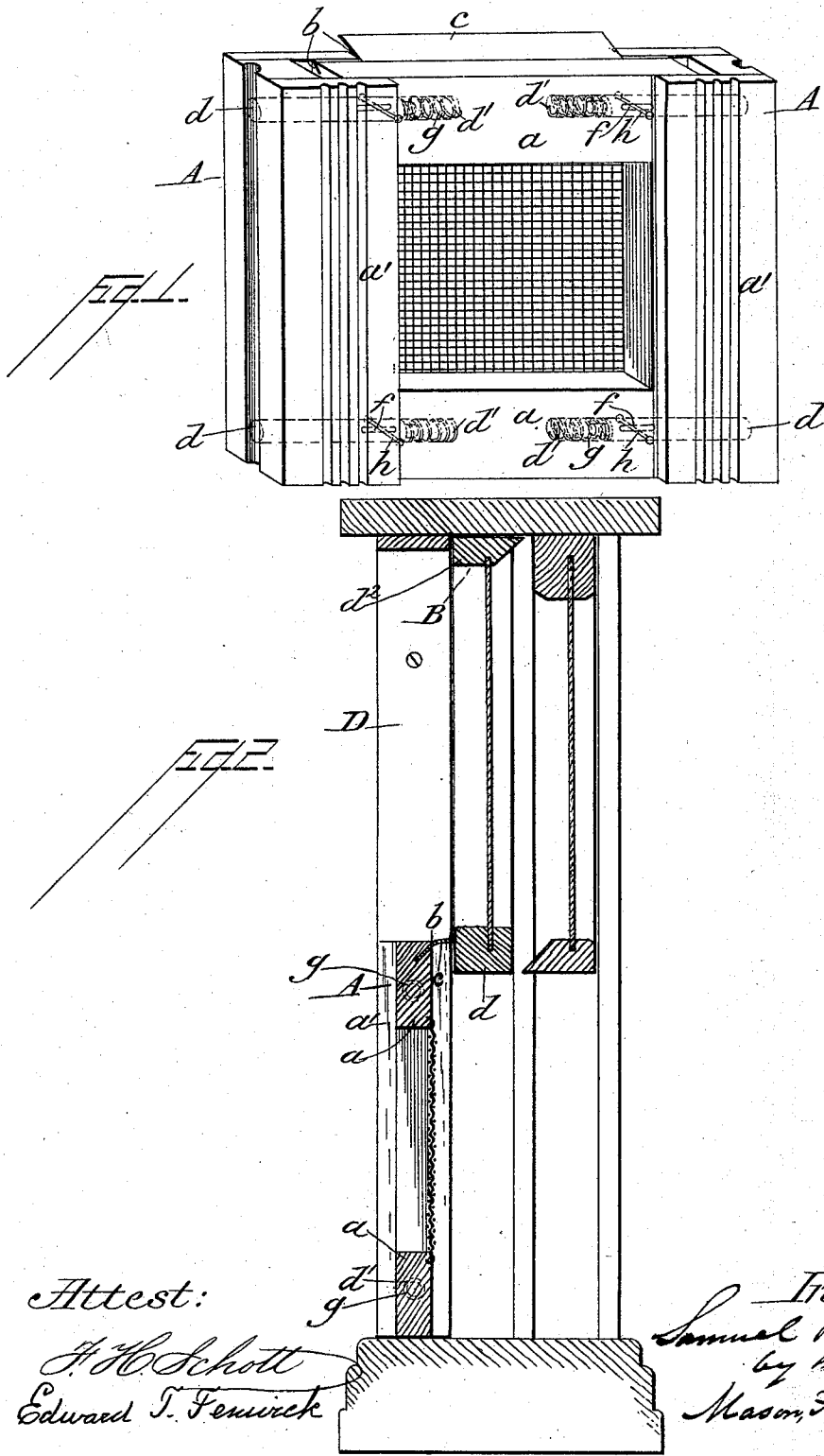

Attest:

H. H. Schott
Edward T. Fenwick

Inventor
Samuel Roebuck
by his attys
Mason, Fenwick & Hamme

(No Model.)

2 Sheets—Sheet 2.

S. ROEBUCK.
WINDOW SCREEN.

No. 416,806.

Patented Dec. 10, 1889.

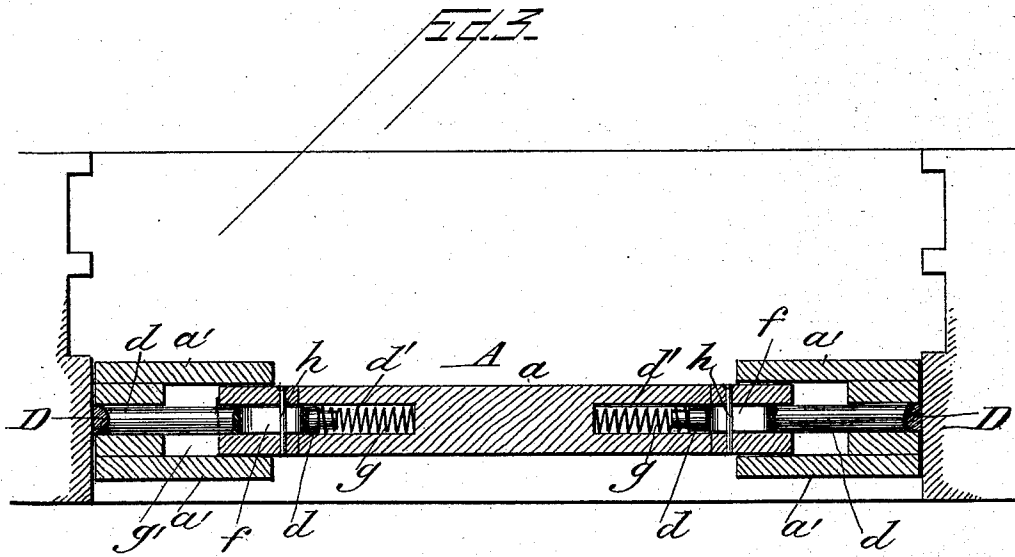

Attest:

J. H. Schott
Edward J. Fenwick

Inventor:
Samuel Roebuck
by his attys
Mason, Fenwick and Lawrence

UNITED STATES PATENT OFFICE.

SAMUEL ROEBUCK, OF NEW YORK, N. Y.

WINDOW-SCREEN.

SPECIFICATION forming part of Letters Patent No. 416,806, dated December 10, 1889.

Application filed April 19, 1889. Serial No. 307,657. (No model.)

To all whom it may concern:

Be it known that I, SAMUEL ROEBUCK, a citizen of the United States, residing at the city of New York, in the county of New York and State of New York, have invented certain new and useful Improvements in Window-Screens; and I do hereby declare the following to be a full, clear, and exact description of the invention, such as will enable others skilled in the art to which it appertains to make and use the same, reference being had to the accompanying drawings, forming a part of this my specification of said invention.

My invention consists, first, in a novel manner of applying a flexible strip at the top of the screen-frame proper, so as to close against the entrance of insects the crevice between the lower cross-rail of the lower sash and the upper cross-piece of the screen-frame proper and the side expansion portions of the screen, and in a novel manner of applying the expanding-springs, the guide, and the expansion-limitation devices.

In the accompanying drawings, Figure 1 is a perspective view of my improved window-screen detached from the window. Fig. 2 is a vertical section of the same in the window, and Fig. 3 is a horizontal section.

The window-screen A as represented is capable of expansion and contraction for adaptation to different-sized windows, and in this respect does not differ materially from those now in use. At the rear corner of the upper cross-piece of the screen-frame proper *a* a diagonal kerf *b* is formed, and into this kerf a strip of india-rubber cloth or other suitable flexible material C is inserted, so that when bent over at nearly a right angle to the face of the screen it will impinge against the front surface of the bottom cross-piece *d* of the window-sash B or slightly overhang the same whenever said sash is raised or opened, and also will impinge against the front surface of the top cross-piece *d*² when said sash is down or closed. The flexible strip is preferably reduced in width at its ends, though not necessarily, and these narrowed portions are secured in that portion of the kerf *b* which is in the vertical sides of the screen-frame proper *a*, so that their upper edges are just about flush with the top surface of said side pieces.

By having the strip flexible and constructed

and arranged as described and shown it is practicable to bend the wider portion of the rubber strip, so that its top surface will be just about flush with the upper surface of the top cross-piece of said screen-frame proper *a*. The strip by being flexible can be made to fit close against the sash without inconvenience from binding, and also will accommodate itself to the window-sash, and thus it always insures a closed joint against the entrance of flies and other insects between the screen-frame and the window-sash along the space between the vertical edges of the two side pieces of the screen-frame proper *a* when the lower sash is raised so that its lower rail is up to the flexible strip. As usual, the expansion portions *a'* *a'* of the screen A are grooved and made thicker than the screen-frame proper *a* at their outer edges, where they are solid, while they are grooved from said solid edges inward for about two-thirds of their width, so as to overlap the screen-frame proper *a* and be capable of sliding inward under the flexible rubber strip C to the extent required in fitting the screen A within different-sized window-frames, as shown.

In the normally-expanded condition of the window-screen the expansion portions may or may not reach closely up to the ends of the wider portion of the flexible strip C; but when the screen is put into use and thereby contracted to fit a window-screen of less width than the screen these expansion portions must extend close up to said ends or pass under said wider portion of the flexible strip. The expansion portions serve for closing the crevice between the screen A and the sash lateral to or beyond the ends of the flexible strip, and thus a complete exclusion of insects is accomplished when the sash is raised so that its lower rail is up to the flexible strip.

In the solid uprights of each of the expansion portions *a'* two horizontal guide-pins *d* are fastened permanently, and in the screen-frame proper *a* horizontal socket-holes *d'* for the reception of these pins are bored, and at the inner terminus of these socket-holes spiral springs *g* are set, and against said springs the inner ends of the pins bear, as shown. Through the pins slots *f* are cut, and through these slots limitation-stops *h* are passed, said stops being fastened in the screen-frame proper *a*,

and serving both for connecting the expansion portions *a' a'* to said frame proper *a* and limiting the movement of the expansion portions.

5 The screen *A* is applied, as usual, to a window-frame by means of portable half-round strips *D*, furnished with the screen and screwed to the inner side surfaces or bead-strips of said window-frame.

10 By my invention of flexible strip simplicity and cheapness are secured and a means provided whereby flies and other insects can be effectually excluded, as said strip adapts itself to window-sashes which may not have their inner surfaces parallel with the vertical
15 faces of the screen *A*.

What I claim as my invention is—

1. In a window-screen, in combination, the screen frame proper *a*, the grooved expansion portions *a' a'*, and the flexible strip *c*, applied
20 to the upper rear edge of said screen-frame proper, so that the said expansion portions

may slide in under it, substantially as described.

2. In a window-screen, in combination, the screen-frame proper *a*, having kerf *b*, the
25 grooved expansion portions *a' a'*, and the flexible strip *c*, reduced in width at its ends and inserted into the said kerf at the upper rear edge of the said screen-frame, so that the expansion portions may slide in under it, and
30 that the space formed by raising the window-sash shall be closed against insects by the joint action of the strip and the rear bearing parts of said expansion portions, substantially as described.

35 In testimony whereof I hereunto affix my signature in presence of two witnesses.

SAMUEL ROEBUCK.

Witnesses:

THEO. F. BOURNE,
JOHN M. SPEER.