

(19) World Intellectual Property Organization
International Bureau



(43) International Publication Date
31 December 2008 (31.12.2008)

PCT

(10) International Publication Number
WO 2009/001033 A1

- (51) International Patent Classification: **F02B 19/08** (2006.01)
- (21) International Application Number: PCT/GB2008/002060
- (22) International Filing Date: 16 June 2008 (16.06.2008)
- (25) Filing Language: English
- (26) Publication Language: English
- (30) Priority Data: 0712185.8 23 June 2007 (23.06.2007) GB
- (71) Applicant (for all designated States except US): **MUSI ENGINES LIMITED** [GB/GB]; 139 Baginton Road, Coventry CV3 6FY (GB).
- (72) Inventor; and
- (75) Inventor/Applicant (for US only): **MERRITT, Dan** [GB/GB]; 139 Baginton Road, Coventry CV3 3FY (GB).
- (74) Agent: **GEE, Steven, William**; D.W. & S.W. GEE, 1 South Lynn Gardens, London Road, Shipston on Stour CV36 4ER (GB).
- (81) Designated States (unless otherwise indicated, for every kind of national protection available): AE, AG, AL, AM, AO, AT, AU, AZ, BA, BB, BG, BH, BR, BW, BY, BZ, CA, CH, CN, CO, CR, CU, CZ, DE, DK, DM, DO, DZ, EC, EE, EG, ES, FI, GB, GD, GE, GH, GM, GT, HN, HR, HU, ID, IL, IN, IS, JP, KE, KG, KM, KN, KP, KR, KZ, LA, LC, LK, LR, LS, LT, LU, LY, MA, MD, ME, MG, MK, MN, MW, MX, MY, MZ, NA, NG, NI, NO, NZ, OM, PG, PH, PL, PT, RO, RS, RU, SC, SD, SE, SG, SK, SL, SM, SV, SY, TJ, TM, TN, TR, TT, TZ, UA, UG, US, UZ, VC, VN, ZA, ZM, ZW.
- (84) Designated States (unless otherwise indicated, for every kind of regional protection available): ARIPO (BW, GH, GM, KE, LS, MW, MZ, NA, SD, SL, SZ, TZ, UG, ZM, ZW), Eurasian (AM, AZ, BY, KG, KZ, MD, RU, TJ, TM), European (AT, BE, BG, CH, CY, CZ, DE, DK, EE, ES, FI, FR, GB, GR, HR, HU, IE, IS, IT, LT, LU, LV, MC, MT, NL,

[Continued on next page]

(54) Title: INTERNAL COMBUSTION ENGINE

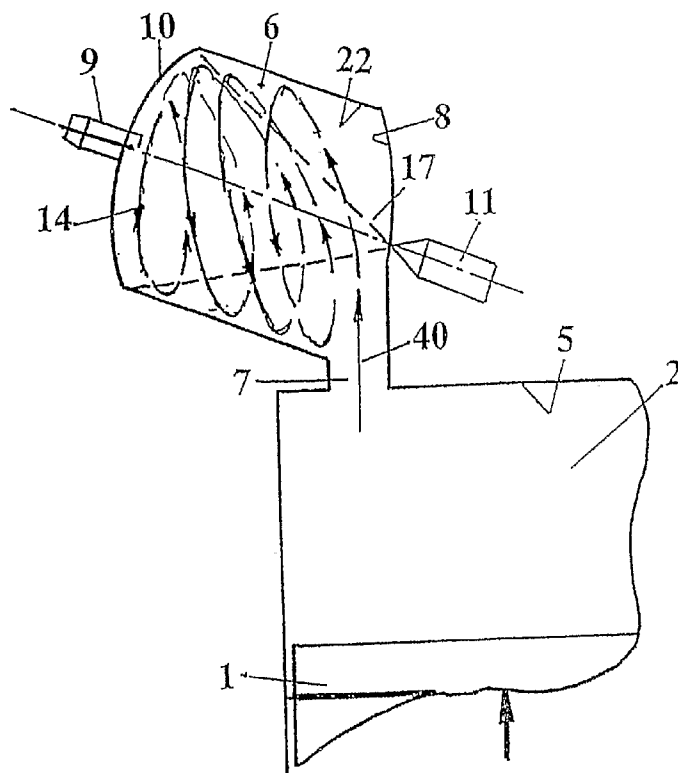

FIGURE 1

(57) Abstract: A reciprocating internal combustion engine. The present invention improves the spark ignition facility used by the engine inventions described in patent publications WO2005/052335 and WO2007/080366 by providing a device to ensure reliable spark ignition by protecting the spark plug from malfunction by sooting.

WO 2009/001033 A1



NO, PL, PT, RO, SE, SI, SK, TR), OAPI (BF, BJ, CF, CG,
CI, CM, GA, GN, GQ, GW, ML, MR, NE, SN, TD, TG).

— *before the expiration of the time limit for amending the
claims and to be republished in the event of receipt of
amendments*

Published:

— *with international search report*

INTERNAL COMBUSTION ENGINE

This invention relates to spark ignited reciprocating internal combustion engines capable of operating over a large part or all of their functioning range without restricting its air
5 intake at part load.

This invention describes the detailed design of the location of the spark plug used in such engines which are described in the international patent publication numbers WO2005/052335 and WO2007/080366 .

10

Accordingly this invention provides an internal combustion engine comprising;

a piston reciprocating in a cylinder;

air inlet means communicating with the cylinder;

exhaust means communicating with the cylinder;

15 an indirect combustion chamber communicating with the cylinder comprising a near end and a far end in relation to the piston;

transfer orifice communicating with the cylinder and the combustion chamber at its near end; means to promote air movement within the combustion chamber in helical swirl

20 motion having tangential velocity component around the combustion chamber and an axial velocity component along the combustion chamber, the axial velocity component being

directed away from the near end and towards the far end;

at least one fuel injector communicating with the combustion chamber;

a controller to control the fuel injection process and spark ignition event;

spark ignition means communicating with the combustion chamber at its far end;

25 characterised in that the far end of the combustion chamber has a substantially concentric protrusion into the chamber facing the near end which forms an annular groove with the periphery of the combustion chamber, the protrusion containing a hole for a spark plug which communicates with the said groove through an aperture allowing the spark to be exposed to the air fuel mixture rotating in the said groove to enable direct spark ignition of
30 the mixture.

The invention is further described herein by way of example with reference to accompanying schematic diagrams which are not drawn to scale and are presented for illustration purposes only.

5 Figure-1 illustrates a combustion chamber design as part of an engine described in international patent publications WO2005/052335 and WO2007/080366. (Figure 1 shows a transfer orifice 7 which is inclined to the axis of the combustion chamber as in patent publication WO2005/052335 but the present invention is equally applicable to an engine where the transfer orifice is perpendicular to the axis of the combustion chamber as
10 described in patent publication WO2007/080366);.and

Figure-2 illustrates a partial section of the combustion chamber along its axis.

In the arrangement of Figure-1 the piston 1 moves upwardly as drawn in cylinder 2 during
15 the compression stroke. The combustion chamber 6 shown in this embodiment is cylindrical and communicates with cylinder 2 through transfer orifice 7. The fuel injector 11 delivers fuel across the air jet 40 towards the far end of the combustion chamber 10 where spark plug 9 is situated. The diagram also illustrates a streamline 14 rotating around the periphery 22 of the combustion chamber in helical swirl motion. Transfer orifice 7
20 enters the combustion chamber adjacent to its periphery in order to impart swirl to the air moving in the chamber and an inclined helical ramp situated at the near end of the chamber 8 (not shown) imparts a longitudinal velocity component to the air entering the chamber to promote helical swirl motion. Cylinder 2 communicates with inlet and exhaust valves (not shown) in known fashion.

25

Controlling the timing of the start of fuel injection ensures that some of the fuel spray cone
17 reaches the far end of the combustion chamber 10 during the early part of the compression stroke before it is fully absorbed into the air jet 40 entering the combustion chamber through transfer orifice 7 because the magnitude of the air jet velocity and the air
30 density are smaller at the start of the compression stroke and increase substantially towards the end of the compression stroke. When this fuel reaches the far end 10 at the earlier part of the compression stroke it may be deposited on the wall there but it soon vaporises when the helical swirl air flow arrives at the far end with sufficient magnitude.

This ensures that the spark plug 9, situated near the far end can be supplied with an ignitable air fuel mixture irrespective of the distribution of fuel nearer the near end 8 of the combustion chamber.

5 A difficult practical problem associated with the invention of patent publications WO2005/052335 and WO2007/080366 is the need to avoid wetting the spark plug with liquid fuel during the early part of the fuel injection process. Fuel injector 11 points directly at the spark plug 9 at the far end 10 making this unavoidable. After such wetting the spark plug electrodes soon become covered with carbon soot which conducts
10 electricity and extinguishes the spark.

Attempts were made to solve this problem by using an ignition pot, a device well known to engine designers. These allowed the engine to function but proved unsatisfactory in practice. Ignition pots are small cavities of a fixed volume, which contain the electrodes
15 end of the spark plug and communicate with the combustion chamber through a hole. When applied to the engine inventions described in publications WO2005/052335 and WO2007/080366, the communication hole was situated on the far end face of the combustion chamber 10 and was machined inclined to the axis of the combustion chamber to stop direct entry of fuel spray through this communication hole.

20

The principle of the ignition pot is to allow gas, in this case air fuel mixture, to be compressed into the ignition pot cavity during the compression stroke. After ignition the burning gases emerge from the ignition pot cavity under pressure as a plasma or a flaming
25 jet igniting the mixture outside. The problems encountered when used with the above engine invention was the inability of the ignition pot to ensure ignition in every engine cycle, resulting in misfires, possibly because of failure to remove from the ignition pot products of combustion of an earlier cycle.

Figure 2 illustrates the device invented to solve this problem. It is self evident that unless
30 reliable spark ignition can be achieved with an engine according to the inventions described in patent publications WO2005/052335 and WO2007/080366 such engines cannot function reliably.

In Figure 2 the end cap 212 is attached to the far end of the combustion chamber 6 by bolts (not shown), but the end cap can be made integral with the combustion chamber if desired.

5 The end cap contains a screw threaded hole shown as 9A with a screw thread which secures the spark plug (not shown). The spark plug hole is shown eccentric to the axis of the combustion chamber to allow close proximity to the periphery. The end cap shown contains a cylindrical protrusion 209 which is substantially concentric with the combustion chamber and which projects into the combustion chamber over a short
10 distance; it is shown with a bevelled free end as a preferred embodiment.

The protrusion forms an annular groove 210 with the periphery of the combustion chamber. It has been found that the radial width of this annular groove is important for the operation of the device as it contains the swirling air fuel mixture which, during the
15 compression stroke, is concentrated around the periphery of the chamber 22, under the influence of centrifugal force. The radial width of the annular groove will depend on the intensity of the helical swirl flow chosen by the designer to influence the speed of combustion and needs to be optimised for a given engine geometry.

20 Facing the annular groove in one location is a slot 211 communicating between the spark plug electrodes and the groove 210. The spark plug electrodes are placed substantially opposite the slot. The slot can be made with a substantial length around the periphery of 209, for example four times its height, but is preferably placed around the thinnest wall between the eccentric spark plug hole 9A and annular groove 210, provided that
25 incandescence is avoided. Spark plug hole 9A is placed in an eccentric position to the protrusion 209 in order to reduce the thickness of the wall around the slot 211.

The present invention prevents liquid fuel from being directly deposited on the spark plug electrodes since the slot 211 is, in this embodiment, placed on a wall parallel with the axis
30 of the combustion chamber. It also allows a generous opening between the spark plug electrodes and the rest of the combustion chamber to minimise the amount of products of combustion remain around the spark plug after ignition to upset the ignition of subsequent

cycles. The spark plug electrodes can have a direct line of sight with the air fuel mixture rotating in annular groove 210.

The present invention is crucially important since it allows the engine to operate reliably
5 without spark malfunction. It is not an obvious solution to a man skilled in the art but is a result of substantial research and development on an engine test bed, it has been found to work extremely well.

CLAIMS

- 1 An internal combustion engine comprising
a piston reciprocating in a cylinder;
- 5 air inlet means communicating with the cylinder;
exhaust means communicating with the cylinder;
an indirect combustion chamber communicating with the cylinder comprising a
near end and a far end in relation to the piston;
a transfer orifice communicating with the cylinder and the combustion chamber at
10 its near end;
means to promote air movement within the combustion chamber in helical swirl
motion having tangential velocity component around the combustion chamber and
an axial velocity component along the combustion chamber, the axial velocity
component being directed away from the near end and towards the far end;
- 15 at least one fuel injector communicating with the combustion chamber;
a controller to control the fuel injection process and spark ignition event;
spark ignition means communicating with the combustion chamber at its far end;
characterised in that the far end of the combustion chamber has a substantially
concentric protrusion into the chamber facing the near end which forms an annular
20 groove with the periphery of the combustion chamber the protrusion contains a
hole for a spark plug which communicates with the said groove through an
aperture allowing the spark to be exposed to the air fuel mixture rotating in the
said groove to enable direct spark ignition of the mixture.
- 25 2. An engine according to claim 1 wherein the aperture is in the form of a slot.
3. An engine according to claim 1 wherein the protrusion is cylindrical.
4. An engine according to claim 1 and claim 3 wherein the protrusion has a bevelled
30 edge at its free end.
5. An engine according to claim 1 wherein a fuel injector delivers fuel towards the
far end of the combustion chamber.

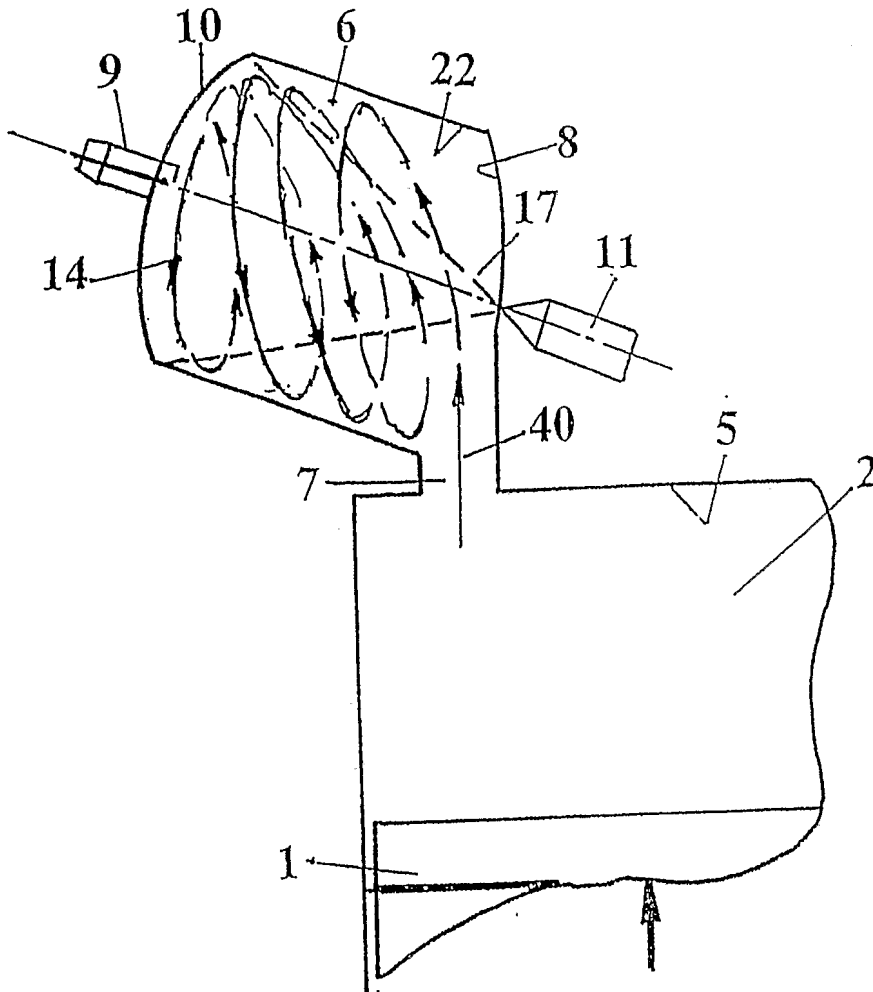

FIGURE 1

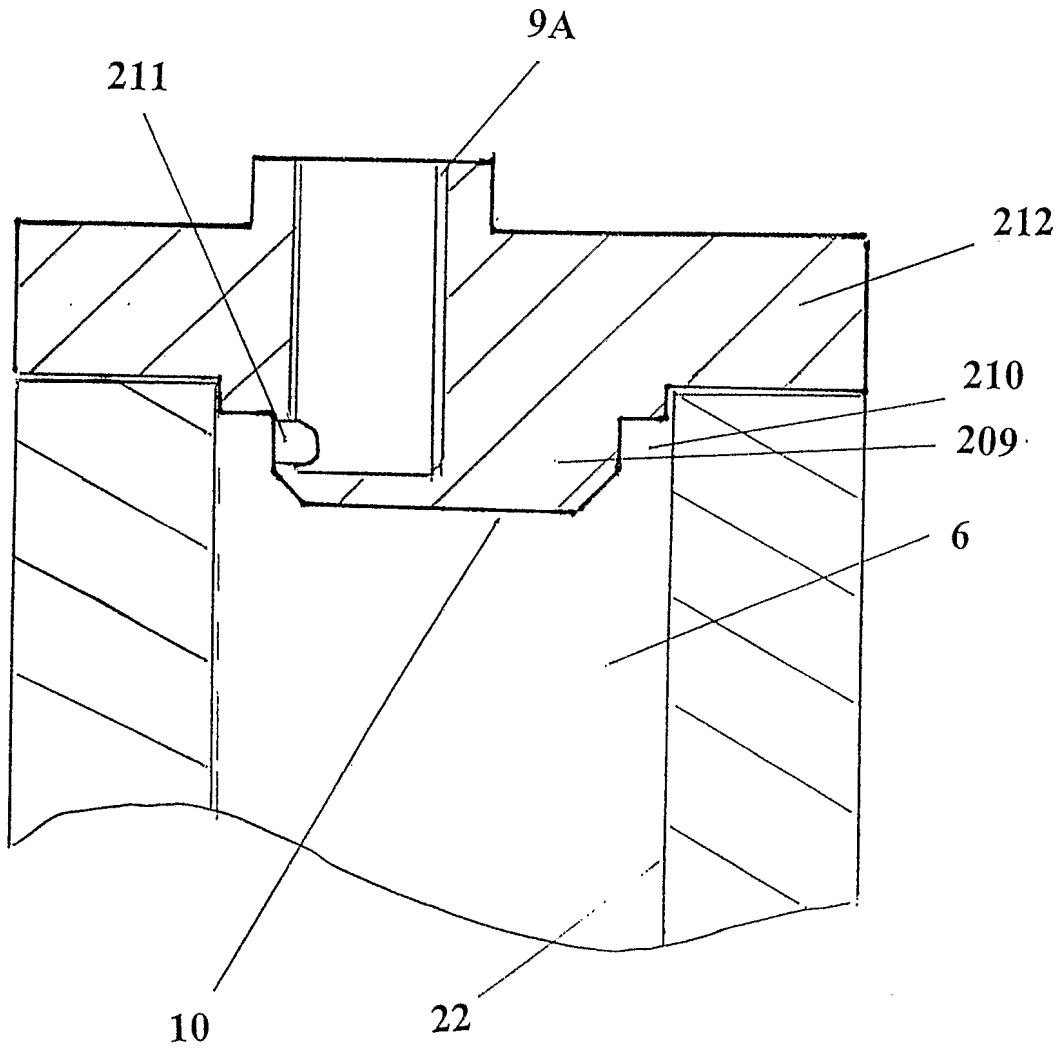

FIGURE 2

INTERNATIONAL SEARCH REPORT

International application No
PCT/GB2008/002060

A. CLASSIFICATION OF SUBJECT MATTER INV. F02B19/08		
According to International Patent Classification (IPC) or to both national classification and IPC		
B. FIELDS SEARCHED		
Minimum documentation searched (classification system followed by classification symbols) F02B		
Documentation searched other than minimum documentation to the extent that such documents are included in the fields searched		
Electronic data base consulted during the international search (name of data base and, where practical, search terms used) EPO-Internal		
C. DOCUMENTS CONSIDERED TO BE RELEVANT		
Category*	Citation of document, with indication, where appropriate, of the relevant passages	Relevant to claim No.
A	US 2007/051338 A1 (MERRITT DAN [GB]) 8 March 2007 (2007-03-08) the whole document	1-5
A	US 4 124 000 A (GENSLAK STANLEY L) 7 November 1978 (1978-11-07) the whole document	1
A	US 4 248 192 A (LAMPARD ROBERT D) 3 February 1981 (1981-02-03) the whole document	1
<input type="checkbox"/> Further documents are listed in the continuation of Box C. <input checked="" type="checkbox"/> See patent family annex.		
* Special categories of cited documents :		
A document defining the general state of the art which is not considered to be of particular relevance *E* earlier document but published on or after the international filing date *L* document which may throw doubts on priority claim(s) or which is cited to establish the publication date of another citation or other special reason (as specified) *O* document referring to an oral disclosure, use, exhibition or other means *P* document published prior to the international filing date but later than the priority date claimed	*T* later document published after the international filing date or priority date and not in conflict with the application but cited to understand the principle or theory underlying the invention *X* document of particular relevance; the claimed invention cannot be considered novel or cannot be considered to involve an inventive step when the document is taken alone *Y* document of particular relevance; the claimed invention cannot be considered to involve an inventive step when the document is combined with one or more other such documents, such combination being obvious to a person skilled in the art. *&* document member of the same patent family	
Date of the actual completion of the international search	Date of mailing of the international search report	
23 October 2008	30/10/2008	
Name and mailing address of the ISA/ European Patent Office, P.B. 5818 Patentlaan 2 NL - 2280 HV Rijswijk Tel. (+31-70) 340-2040, Fax: (+31-70) 340-3016	Authorized officer Van Zoest, Peter	

INTERNATIONAL SEARCH REPORT

International application No

PCT/GB2008/002060

Patent document cited in search report	Publication date	Patent family member(s)	Publication date
US 2007051338	A1	08-03-2007	NONE
US 4124000	A	07-11-1978	NONE
US 4248192	A	03-02-1981	NONE