

W. AVERY.
 MACHINE FOR TURNING AND NICKING THE HEADS OF SCREWS.
 948,492.

APPLICATION FILED FEB. 27, 1909.

Patented Feb. 8, 1910.
 8 SHEETS—SHEET 1.

FIG. 1.

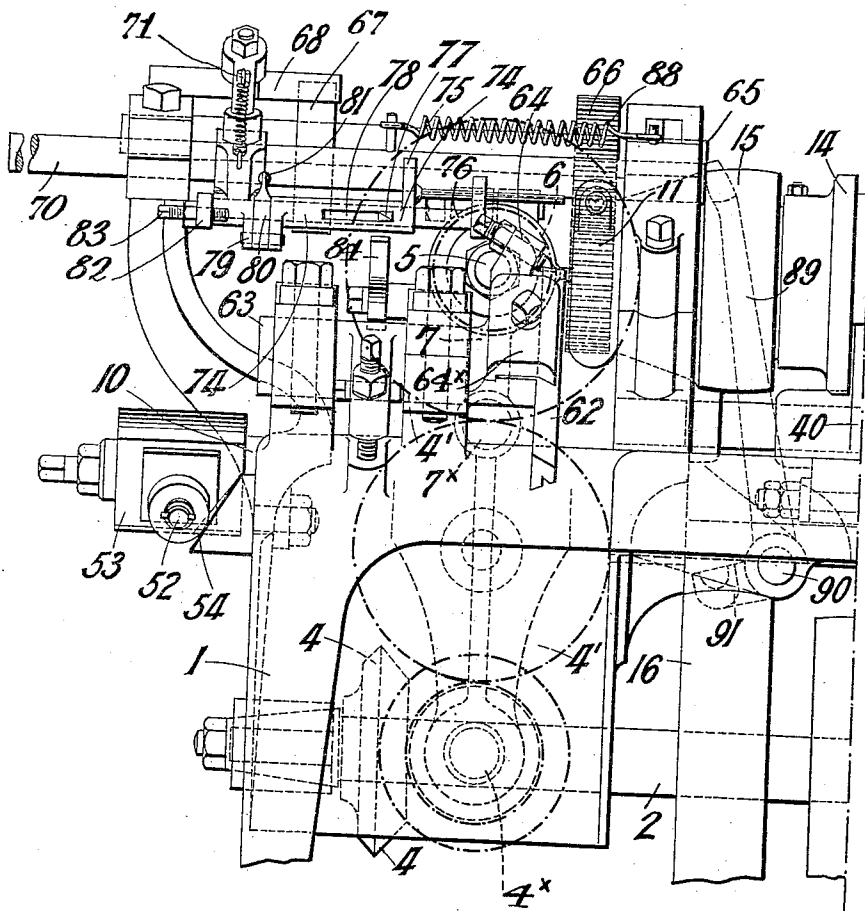

Witnesses:

G. E. Gayette
M. E. Smooh

Inventor:

William Avery
 by his attorney
R. L. Quinn

W. AVERY.
 MACHINE FOR TURNING AND NICKING THE HEADS OF SCREWS.
 APPLICATION FILED FEB. 27, 1909.

948,492. Patented Feb. 8, 1910.
8 SHEETS—SHEET 2.

Fig. 1. Continued.

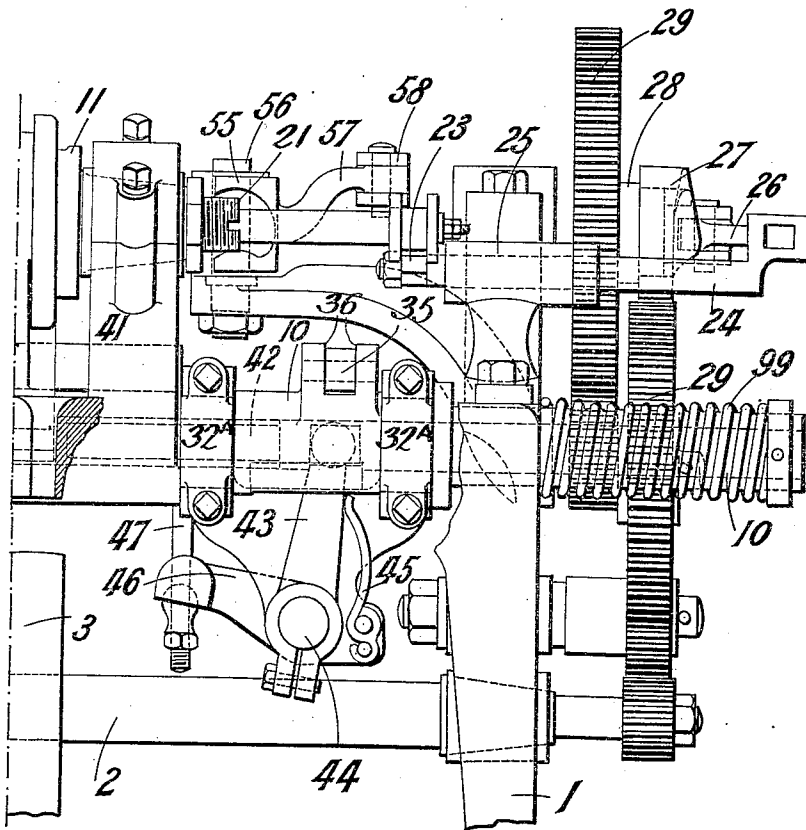

Witnesses:
Geo. C. Gannett
M. E. Smoot

Inventor:
William Avery
by his attorney
R. L. Ewin

FIG. 2.

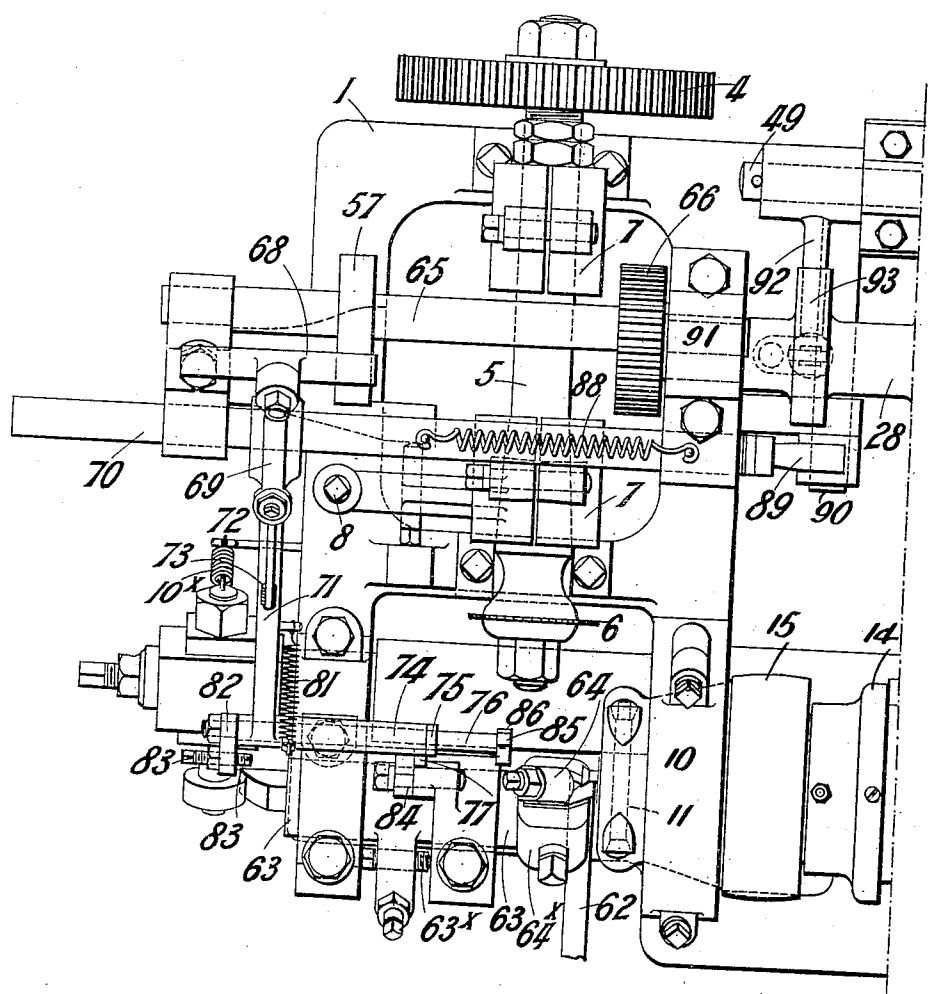

Witnesses:
G. E. Clauette
M. E. Smoot

Inventor:
 William Avery
 by his attorney
R. L. Quinn

FIG. 2. Continued.

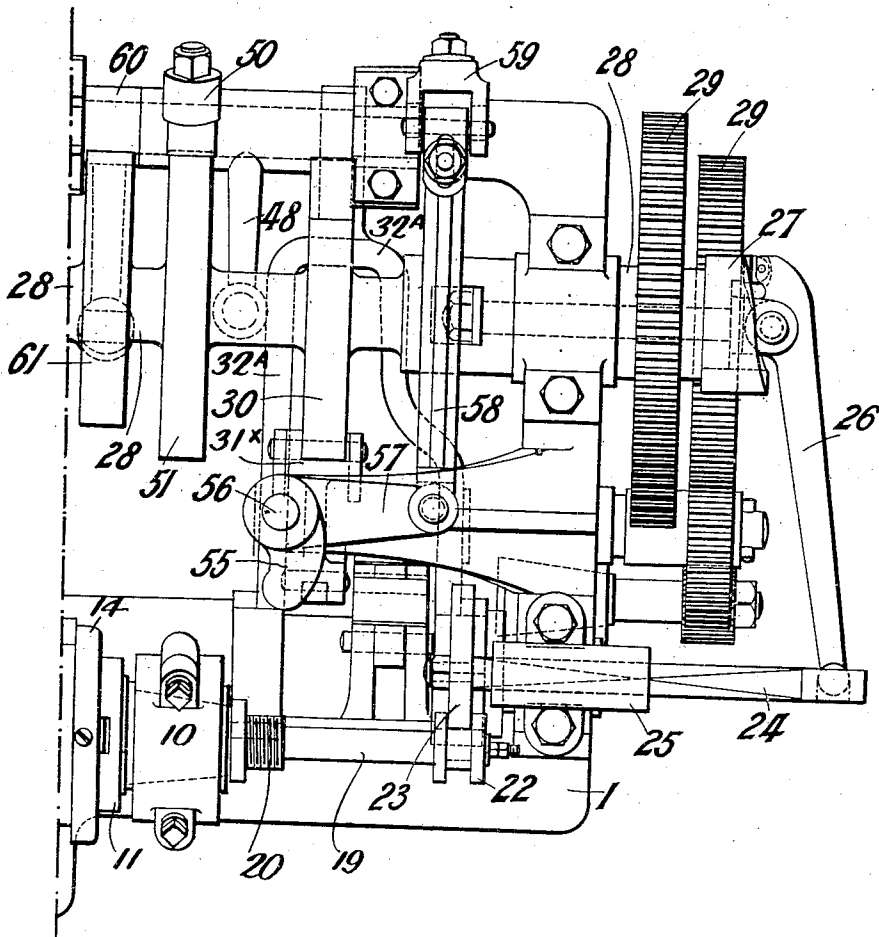

Witnesses:

J. C. Clauett
M. D. Smoot

Inventor:

William Avery
 by his attorney
R. L. Swin

W. AVERY.
MACHINE FOR TURNING AND NICKING THE HEADS OF SCREWS.
APPLICATION FILED FEB. 27, 1909.

948,492. Patented Feb. 8, 1910.
8 SHEETS—SHEET 5.

FIG. 3.

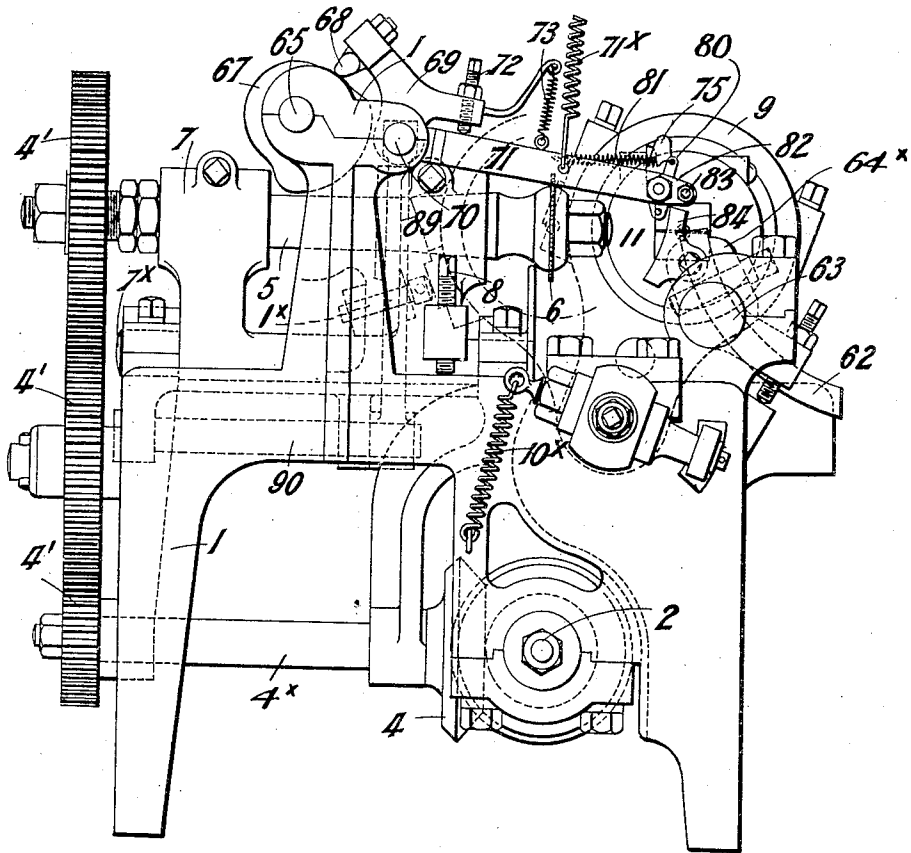

Witnesses:

J. C. Laute
M. E. Smoot

Inventor:

William Avery
by his attorney
R. L. Ewin

W. AVERY.
MACHINE FOR TURNING AND NICKING THE HEADS OF SCREWS.
APPLICATION FILED FEB. 27, 1909.

948,492.

Patented Feb. 8, 1910.
8 SHEETS—SHEET 6.

FIG. 4.

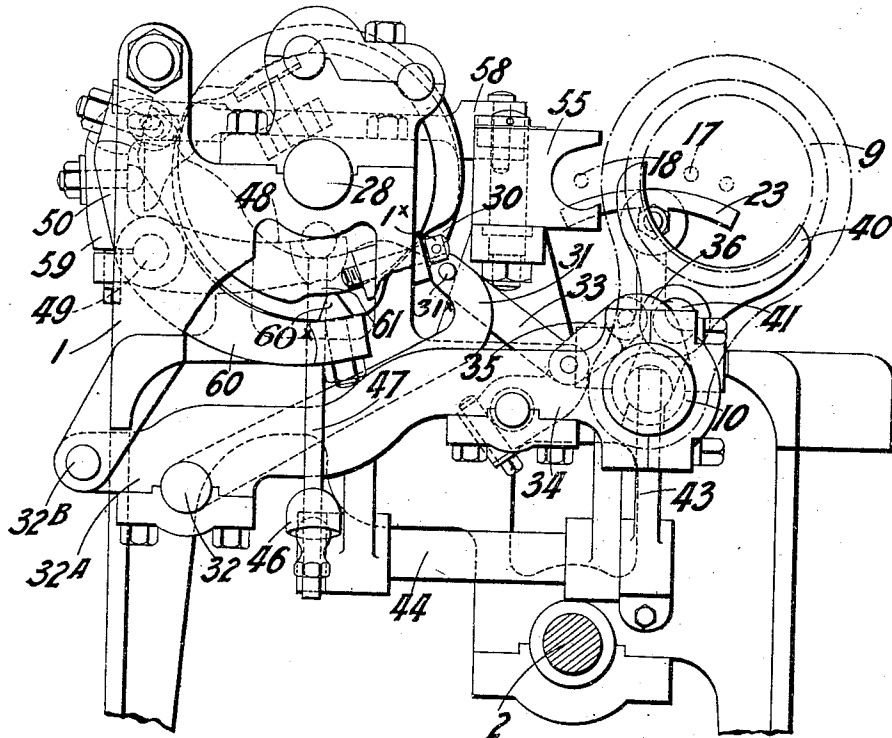

Witnesses:
J. C. Clavett
M. E. Smoot.

Inventor:
William Avery
by his attorney
W. L. Ewin.

W. AVERY.

MACHINE FOR TURNING AND NICKING THE HEADS OF SCREWS.

APPLICATION FILED FEB. 27, 1909.

948,492.

Patented Feb. 8, 1910.

8 SHEETS—SHEET 7.

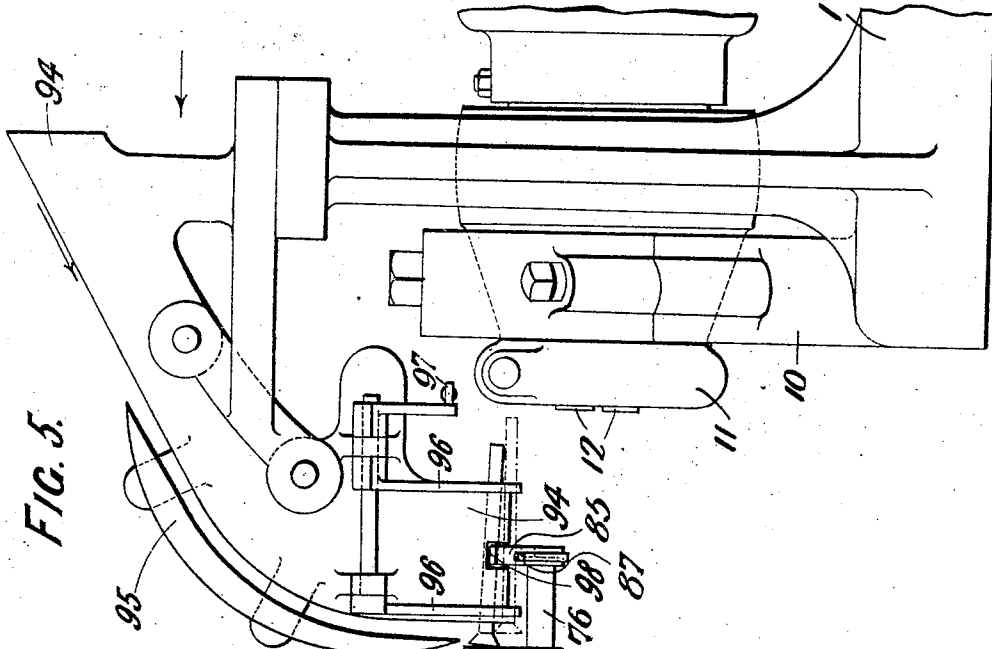

FIG. 5.

FIG. 7.

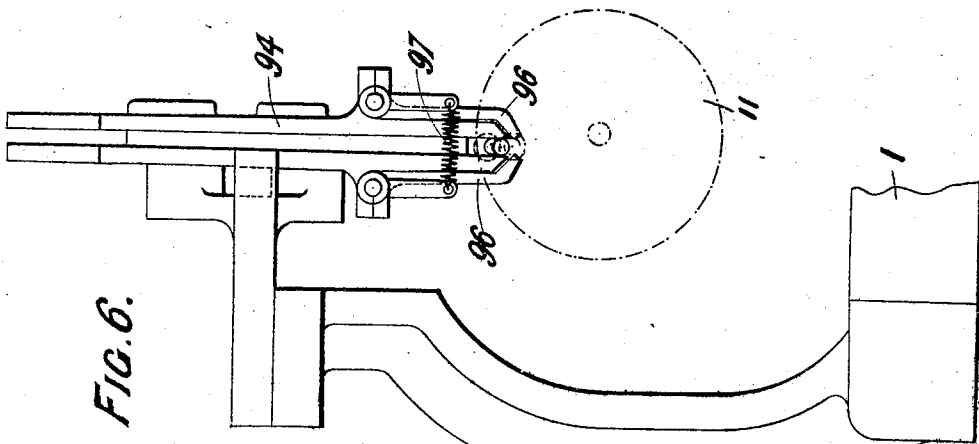
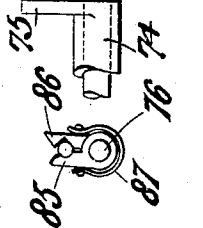

FIG. 6.

Witnesses:

W. E. Clauette
M. E. Smart.

Inventor:

William Avery
by his attorney
R. L. Ewin.

W. AVERY.
 MACHINE FOR TURNING AND NICKING THE HEADS OF SCREWS.

948,492.

APPLICATION FILED FEB. 27, 1909.

Patented Feb. 8, 1910.

8 SHEETS—SHEET 8.

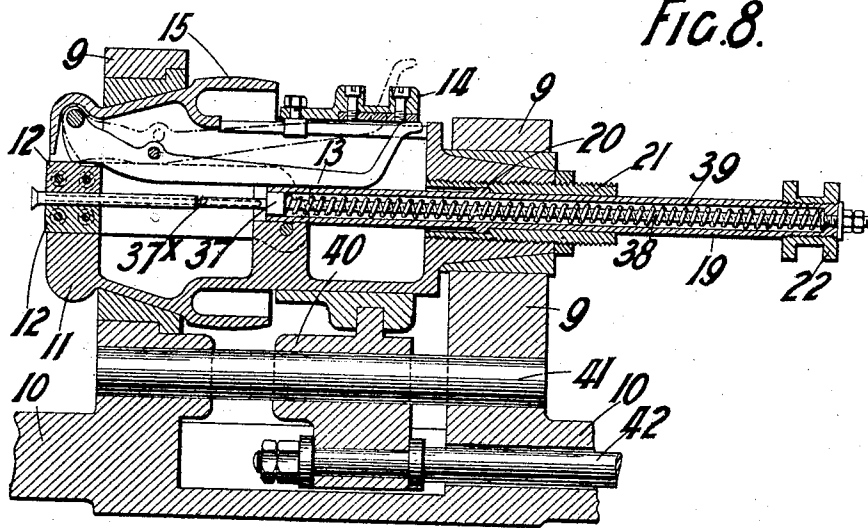

FIG. 8.

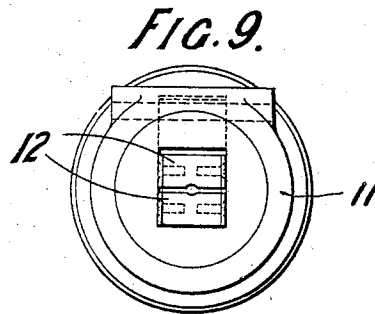

FIG. 9.

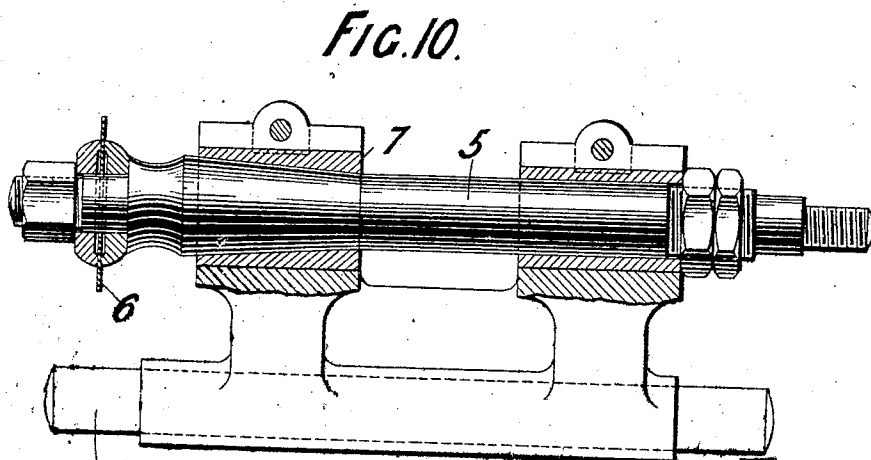

FIG. 10.

7x Witnesses:
J. C. Quast
M. C. Smoot.

Inventor:
William Avery
 by his attorney
D. L. Swin.

UNITED STATES PATENT OFFICE.

WILLIAM AVERY, OF RICHMOND, ENGLAND.

MACHINE FOR TURNING AND NICKING THE HEADS OF SCREWS.

948,492.

Specification of Letters Patent.

Patented Feb. 8, 1910.

Application filed February 27, 1909. Serial No. 480,450.

To all whom it may concern:

Be it known that I, WILLIAM AVERY, a subject of the King of Great Britain, residing at Richmond, in the county of Surrey, England, engineer, have invented certain new and useful Improvements in Machines for Turning and Nicking the Heads of Screws, and of which the following is a specification.

The improved machine which is the subject of the present invention, is supplied with screw blanks, each of which has a cylindrical portion, upon which the screw-thread is to be formed, and each blank is already formed with a head, the blanks dealt with specially in this specification, having heads of the form common with wood screws, that is, each head has a flat face and a coned under part which conjoins the cylindrical stem. The office of the machine is to automatically take such a blank from a feed rail, to turn up the face and the underside of the head by a primary turning operation, to then form the nick or groove diametrically across the face of the head of the blank, and then to finish the head, by subjecting that head to a secondary turning operation, by which any fraise or bur is removed which may have been formed during the nicking process. The machine, therefore, according to this invention, is constructed with certain automatically-acting mechanisms, which co-act with each other, and these mechanisms comprise a feeding device, whereby the screw blanks are taken singly from a guide rail by fingers carried by an arm and are inserted thereby into gripping jaws carried by a spindle supported in bearings upon a rocking frame, the latter frame being at the time in a midway or first position. The jaws are then closed to grip the blank, and the feeding fingers are moved away to gather another blank, and the rocking frame is rocked over to a second position to carry the screw head against a stationary turning tool. As the frame arrives in that position in which the head of the blank is held against the stationary turning tool, the spindle carrying the gripping jaws is given a revolving motion, while the rocking frame is advanced sufficiently, in a plane at right angles to that in which it is rocked to advance the face of the head of the blank against the turning tool, and thus the primary turning operation is carried out upon the screw head. The rocking frame is then rocked over, in an

opposite direction to its first movement but beyond its first position, the jaw-carrying spindle meanwhile automatically ceasing to revolve, and the motion of the rocking frame is stopped when the axis of the blank is brought opposite to a revolving saw carried in stationary bearings, and then the rocking frame receives a forward motion of translation, carrying the spindle with it, which spindle is now stationary, and bringing the head of the blank against the saw to effect the nicking of the head, after which the rocking frame has a retrograde motion of translation in order to draw the head of the blank away from the saw, the nick having been effected. The rocking frame is then again rocked over to its second position in order to again bring the head of the blank in contact with the stationary turning tool; and while the head of the blank is in contact therewith, the jaw-carrying spindle is revolved, and at the same time the rocking frame has a slight end-way motion of translation given to it, and by this means the face of the head of the blank is turned sufficiently to finish that head, and remove any bur or fraise which may have been produced during the nicking operation. Then the rocking frame is returned to its original or first position, the jaw-carrying spindle ceasing its revolution, and the blank is then in a condition in which it is to be discharged, that is, the operations—which it has been the office of this machine to carry out—have been effected.

In order to discharge the blank, a sliding plunger is located within the jaw-carrying spindle, which can act—by means of a spring—with resilient pressure against the rear end of the cylindrical portion of the blank held by the gripping jaws, and during the operations which have been before broadly stated, the spring of such a plunger has been brought into compression. When, therefore, the rocking frame again arrives in its first position ready to deliver the screw blank, this act will be immediately effected by the spring-pressed plunger as soon as the gripping jaws (carried by the spindle) are released.

The gripping jaws being so released at this time, the blank is shot out, and then the feeding fingers—which have already gathered another blank from the guide rail, and which have held that blank in a position to be out of the way of the operations which

have been described—now rise and deliver the blank into the jaws of the spindle, pushing the said blank nearly up to its head therein, and then the feeding fingers retire, and the jaws grip the blank, and the course of operations which have been described are again repeated.

Referring to the accompanying drawings:—Figure 1 is an elevation of the machine. Fig. 2 is a plan view of same. Fig. 3 is a left-hand end view, confined to some of the parts, and Fig. 4 is a sectional view from the same end showing certain other parts of the machine hereafter described. Fig. 5 is an elevation of a guide rail by which the blanks travel to the feed apparatus, this guide rail, shown detached, not being illustrated in the previous views in order to simplify the latter, and Fig. 6 is a rear end view of the said guide rail and its parts, Fig. 7 being an end view of the feed fingers by which the blanks are taken from the guide rail. Fig. 8 shows detached and in vertical section, the spindle carrying the gripping jaws, and also illustrates the ejection mechanism therein, Fig. 9 being a front elevation of the spindle. Fig. 10 is a sectional elevation showing the nicking saw which is carried in stationary bearings.

The machine consists of a stationary framework 1, from which the various mechanisms are carried, and on that framework is mounted, in any suitable bearings, a driving shaft 2, Figs. 1 and 3, having a pulley 3 by which it receives rotary or, as it is herein termed, revolving motion. From the shaft 2, motion is communicated, by trains of wheels 4 and 4', and a transverse countershaft 4^x, Figs. 1 and 3 to the transversely extending spindle 5 (Fig. 10) of a circular saw 6 carried in bearings in a frame 7, Figs. 1, 2, 3 and 10, mounted on a rock-shaft 7^x Figs. 1 and 3, carried by the framework 1 and capable of being adjusted by a set screw 8 carried from the frame 7, and acting against the framework 1 of the machine, such set screw 8 being shown at Figs. 2 and 3.

The rocking frame 9 (Fig. 8) is carried upon a longitudinal shaft 10 (Fig. 4) mounted in suitable bearings in the framework 1 and capable of rocking and also of being given endwise sliding motions therein, and the said rocking frame 9 carries a spindle 11 comprising a hollow shell, in the forward end of which there is carried a pair of blank-holding jaws 12, Figs. 8 and 9, which will resiliently spring apart and which can be closed by a shaped lever 13 operated by the sliding of a sleeve 14. Said spindle 9 is formed with a pulley surface 15 to receive a belt (not shown) which passes over a pulley 16 (Fig. 1) on the driving shaft 2. The shafts 2 and 10 are so relatively arranged, that when the rocking frame 9 is in the position indicated at Fig.

4, the belt will be taut and the spindle 11 will be rotated, while when the rocking frame 9 is rocked over into its first position indicated by the dotted center 17, (Fig. 4) or into its third position indicated by the dotted center 18 (Fig. 4), the belt is loose and the spindle 11 is not driven. It will be clear that when the sliding sleeve 14 of the rocking frame is slid forwardly, the lever 13 will be released and allowed to assume its dotted position (Fig. 8) and permit the jaws 12 to spring open and release the blank.

Axially through the rear end of the spindle 11 is fitted a sliding tube 19, (Fig. 8) prevented from moving rearwardly by a collar 20 bearing against a screwed adjustable bush 21, and fitted at its rear end with a grooved collar 22, which is engaged by a segment 23 (Figs. 2 and 4) carried by a slide 24 of rectangular section movable in a bearing 25 from the framework 1, the said slide 24 being operated by a lever 26 (Fig. 2), which receives motion, at the proper times, from a cam 27 mounted upon a main cam shaft 28, which latter shaft 28 is driven by gearing 29 (Figs. 1 and 2) from the first motion shaft 2. The necessary rocking motions are communicated to the rocking frame 9 through the medium of a cam 30 Figs. 2 and 4 on the main cam shaft 28, which acts upon a roller 31^x (Figs. 2 and 4) carried by one end of a lever 31 (Fig. 4) capable of rocking about the axis of a shaft 32. The shaft 32 (Fig. 4) upon which the lever 31 is carried is mounted in a movable frame 32^A, Figs. 1, 2 and 4 the rear end of which is loosely carried upon a shaft 32^B, (Fig. 4) the latter being supported from the main framework 1 of the machine. The forward portion of the frame 32^A is bifurcated, which bifurcation is sufficiently illustrated at Figs. 1 and 2, and the ends of the bifurcations (Fig. 1) are formed to embrace the shaft 10 of the rocking frame 9. It is to be understood that the frame 32^A (Fig. 4) is free to have some small sliding motions of translation in the axial direction of the shaft 10 of the rocking frame 9, and the shaft 32 (Fig. 4) which is carried in bearings in this sliding frame 32^A can also share such endwise sliding motions of translation.

To the operated roller-carrying end of the lever 31 is connected one end of a pivoted link 33, (Fig. 4) the other end of which latter is pivoted to a rock lever 34 (Fig. 4) mounted to rock in the aforesaid movable frame 32^A, and the end of the lever 34 is connected by a link 35 to a snug or projection 36 Figs. 1 and 4 forming part of the shaft 10, which is the shaft carrying the rocking frame 9. It will be observed that as the cam 30 revolves, the toggle—composed of the links 33 and 35 and the lever 34—will permit the rocking frame 9 being carried from the position shown at Fig. 4

(its second position) in the direction of its third position (18 Fig. 4), this motion being effected by a helical spring 10^x (Fig. 3) connected to the rear end of the shaft 10 of the rocking frame 9 and to the framework 1; the front end of the machine and of its spindles 5 and 11 and shaft 10 being shown at the left in Figs. 1, 2, 8, and 10.

It will now be understood that the rocking frame 9 and its shaft 10 can have the necessary slight endwise sliding motions of translation which have to take place in the second position of the rocking frame for turning the head of the blank, and in the third position for advancing the blank to the saw and withdrawing it therefrom. In these sliding motions the bifurcated frame 32^A accompanies the shaft 10 of the rocking frame and the roller 31^x carried by the lever 31 is of such width that it bears upon the cam 30 throughout those endwise sliding motions of the rocking frame 9 which it shares.

Referring to Fig. 8, the sliding tube 19 contains a plunger 37 having a forward extension 37^x and a sliding rod 38 extends from the plunger 37, and has mounted upon it a helical spring 39 acting between the closed rear end of the tube 19 and the said plunger 37, the office of the plunger being to act, by its extension 37^x, upon the rear end of the blank when the sliding tube 19 is moved forwardly so that, when at the proper time, the jaws 12 release the blank, it will be shot out.

In order to give the necessary sliding motions to the sleeve 14 (Fig. 8) by which the jaws 12 are opened and closed at the proper times, the said sleeve 14 is engaged by a clutch piece 40 slidable on a rod 41 carried by the rocking frame 9, and the piece 40 is operated by a sliding rod 42 passing through a bore of the shaft 10.

The end of a lever 43 (Fig. 1) mounted on a rock-shaft 44 passes through a slot in the shaft 10 and engages in a slot in the rod 42, and this lever 43 is acted upon by a spring 45 tending to move the sleeve 14 of the rocking frame forwardly to release the jaws. A lever 46 on the rock-shaft 44 is connected, by a connecting rod 47 (Fig. 4), to one arm 48 (shown in dotted lines at Fig. 4) of a two-armed lever rocking on a spindle 49, the other arm 50 of which lever is operated by the cam 51 (Fig. 2) on the main cam shaft 28.

As aforesaid, the rocking frame 9 is given two slight endwise motions, the first when it is in its second position for advancing the blank head against the cutting tool, and the second forward sliding motion when it is in its third position in order to advance the blank to the saw. The first of these endwise sliding motions of the rocking frame is effected by the forward end of the shaft 10 (Fig. 1) projecting beyond the framework

1 and carrying a roller 52 on a longitudinally adjustable collar 53, which roller 52 bears against an inclined stationary surface 54 carried by the framework 1, so that as the rocking frame is thrown over to bring the blank head against the cutting tool, it is also drawn forwardly to effect a cut on the face of the blank head. When the rocking frame is rocked over, by the means described, to its third position indicated by the dotted center 18 (Fig. 4) the said frame 9 rests against an adjustable stop screw 1^x (Fig. 4) and the rear end of the spindle 11 of the rocking frame is received within the arms of a forked lever 55, (Fig. 4). The arms of the lever 55 act against the rocking frame 9 to give it an endwise movement, the said lever 55 being mounted on a spindle 56 (Fig. 2) carried from the framework, from which spindle an arm 57 extends, which, by a connecting rod 58, is connected to an arm 59 carried by the rock-shaft 49 (Figs. 2 and 4), which rock-shaft also carries a lever 60 (Fig. 2), the end of which carries a contact 60^x (Fig. 4) operated by a cam 61 on the main cam shaft 28.

The stationary cutter or turning tool 62, Figs. 1, 2 and 3, is carried by an adjustable tool-carrying shaft 63, (Fig. 3) carried in bearings in the framework and adjustable toward or away from the end of the spindle 11 by an adjusting screw 63^x, (Fig. 2) while the forward adjustment of the cutter 62 is regulated by the conical end of a set screw 64 (Figs. 1 and 2) the tool being held to the carrying shaft 63 by a clamp 64^x. The cutter 62 is normally stationary, and the blank is brought up to it on two occasions, firstly in order to effect the primary turning operation, and secondly to effect the secondary turning operation for removing the bur or fraise after nicking.

The rocking frame 9 (both after effecting the turning operations upon the head of the blank, and also after effecting the nicking of the head) is returned to its normal position by means of a helical spring 99 (Fig. 1) of suitable strength, mounted upon an extension of the shaft 10 beyond the framework and acting between the said framework and a collar on the end of the said shaft 10, which spring 99 thus serves to bring and hold the shaft 10 to its normal rearward position, after it has been moved forwardly for effecting the turning of the head of the blank and also after the nicking of the said head. As has been before explained, the blank to be operated upon is mechanically fed into the gripping jaws 12. This operation is effected by the mechanism which will now be described.

Mounted in bearings in the framework is a counter-shaft 65 Figs. 1, 2 and 3 receiving rotary motion by means of gearing 66 (Figs. 1 and 2) from the front end of the

cam shaft 28, and carrying a cam 67 which acts upon a bar 68 carried by a rocking member 69 mounted upon a sliding shaft 70 also carried in bearings in the framework 1. The shaft 70 also carries an arm 71 (Fig. 3) held up against an adjustment screw 72 on the member 69 by a spring 73, so that the angle of the arm 71 can be adjusted relatively to the rocking member 69, while the bar 68 permits of the shaft 70 being given endwise motion, and at the same time of the cam 67 acting upon that bar 68 during the period of the said endwise motion of the shaft 70, the member 69 and the arm 71. The arm 71 is normally drawn upward and supported by means of a spring 71^x Fig. 3, attached to the arm 71 and to some stationary point above it, and thereby the rocking member 69 is retained with its bar 68 in contact with the cam 67, while the arm 71 can be rocked by the action of that cam, freely. The free end of the arm 71 carries a sleeve 74 (Figs. 2 and 5) having at its forward end an upstanding lug 75 and through the sleeve 74 there passes a rod 76 having a projection 77 (Figs. 1 and 2) capable of sliding in a slot 78 (Fig. 1) in the sleeve 74 so that the rod 76 can slide in the sleeve 74, but cannot rotate therein. Pivoted to lugs 79 on the sleeve 74 (see Fig. 1) is a brake arm 80 which acts through a slotted part of the sleeve 74 upon the sliding rod 76, being held thereto by a spring 81 (Figs. 1 to 3) connected at one end to the brake arm 80, and at its other end to a pin projecting from the arm 71, and thereby the sliding rod 76 is retained by the friction of the brake arm 80 in whatever position it may have been placed. At one end of the sliding rod 76 is carried by an arm 82, Figs. 1 to 3, an adjustable stop screw 83 which at times is brought into contact with one face of a curved stationary stop 84 (Figs. 2 and 3) while the stud 77 on the rod 76 is brought into contact at times with the opposite face of the stationary stop 84, see Fig. 2. The rear end of the rod 76 carries a fixed finger 85 (Figs. 2, 5 and 7) which co-acts with a pivoted finger 86, also on the rod 76, the finger 86 being held up to the finger 85 by a delicate spring 87.

The sliding shaft 70, Figs. 1 to 3, upon which the arm 71 turns is drawn in a direction to feed the blank—seized by the fingers 85 and 86—into the gripping jaws of the spindle 11 by means of a helical spring 88 (Figs. 1 and 2). The said shaft 70 is mechanically moved in opposition to the spring 88 at the proper times by means of a lever 89 shown by dotted lines at Figs. 1 and 3, which lever is mounted upon a rock-shaft 90, which latter has an arm 91 Figs. 1 and 2 which is connected by a connecting rod, not shown in the drawings to a rock

lever 92 (Fig. 2) loosely mounted on the shaft 49, and the free end of the rock lever 92 is held up to a cam 93 (Fig. 2) mounted on the main cam shaft 28, being so held up through the medium of the aforesaid spring 88.

The blanks are fed singly in between two bars composing a guide rail 94, Figs. 5 and 6, the said blanks hanging by their heads, and sliding down the inclined guide rail by gravity, and being guided by a guide piece 95, Fig. 5 as they pass around a curve in the guide rail 94, until they arrive at the base of the guide rail 94 in a nearly horizontal position. The blanks are prevented from falling out at the end of the guide rail 94 by means of pivoted fingers 96 (Figs. 5 and 6) held together by a spring 97 as shown in Fig. 6, and the lower ends of the bars composing the guide rail 94 are slotted at 98.

It will now be understood that the cam 67, Figs. 1 to 3 permits the arm 71 to be raised by the spring 71^x (Fig. 3) to bring the fingers 85, 86 Figs. 5 and 7 into the position shown at Fig. 5, in which the fingers will have become opened by their inclined ends (Fig. 7) contacting with the lowermost blank and afterward closing around it until the shank of the blank is in the position shown at Fig. 7; and then it lowers the arm 71, the latter carrying the blank gripped in the feeding fingers, the arm 71 coming to rest in a position in which that blank is held below the center of the gripping jaws 12 of the spindle 11. Then when a finished blank has been shot out of the gripping jaws, the arm 71 is raised by the interaction of said spring 71^x and cam 67 until the axis of the blank is co-axial with the open jaws 12 of the spindle 11, and then the spring 88 (Fig. 2) is permitted to act by the cam 93 to slide the shaft 70 in the direction of the jaw carrying spindle. The arm 71 which follows this movement carries with it the rod 76 carrying the feed fingers, and inserts the shank of the blank into the gripping jaws, until the set screw 83 on the arm 82 contacts with the curved stationary stop piece 84, and then the projecting arm 75 on the sleeve 74 completes the insertion of the blank into the gripping jaws. The arm 71 is then lowered by the cam 67 so that the feeding fingers pass away from the blank, and is also drawn away from the jaws of the spindle 11 by the cam 93, and in this motion the stud 77 (Fig. 2) on the rod 76 contacts with the opposing face of the stationary curved stop piece 84, and returns the rod 76 to its normal position, relatively to the sleeve 74 (see Fig. 2) and then the feed fingers 85, 86 are again raised to seize the next blank.

The relative speeds of the various moving parts are so arranged, and the shapes of the

cams by which the motions are produced are so designed as can readily be done by those acquainted with the art, that the action of the machine is such as will now be described.

The feed fingers 85, 86 rise up to the base of the guide rail 94, as shown at Fig. 5, into position to seize a blank in the manner which has been stated, and at this moment the spindle 11 carrying the jaws 12 is not revolving, its center being situated at the position indicated at 18 (Fig. 4) in which the axis of the blank already held by the gripping jaws 12 is directly opposite the plane of the saw 6; the spindle is then moved forward toward the saw by the lever 55 (Fig. 2) acting against the rear end of the spindle 11 and so forcing the latter forwardly along with the rocking-frame 9, and the shaft 10. The saw 6 thus cuts the nick in the face of the blank head held in the jaws 12. At the same time the spring 39 (Fig. 8) is being compressed by the forcing forward of the sliding tube 19, through the medium of the segment 23 (Fig. 4) carried by the sliding bar 24, and operated by the slide lever 26 and ejection cam 27 (Fig. 2). As soon as the blank has been seized by the fingers 85, 86 the spindle 11, with its rocking-frame 9, is drawn back from the saw, by the spring 99, Fig. 1 and the rocking-frame 9 is thrown over to its second position, that is to the dotted position at Fig. 4 in order to effect the secondary turning operation to remove the bur on the head of the blank, and it is during this rock-over motion of the frame 9 that the belt becomes tightened owing to the relative positions of the shafts 2 and 10, and accordingly the spindle is revolved, and the blank carried thereby, while so revolving is subjected to the action of the stationary turning tool 62. While the head of the blank is being thus finished, and the rocking-frame is being given a slight forward movement (by means of the stationary incline 54, Fig. 1) co-acting with the roller 52 carried at the end of the shaft 10) the feed fingers 85, 86 (carrying a blank which is to be operated upon) are being lowered, that is, brought down to a position below the axis of the spindle 11 of the rocking frame 9. The rocking frame 9 is then rocked over into its ejection and blank-receiving position indicated by the dotted center 17 (Fig. 4) and upon reaching this position the gripping jaws 12 are released by the movement of the sliding sleeve 14 (Fig. 8) and the spring 39 which has been placed in compression during the other movements of the rocking-frame is then free to act upon the plunger 37, 37* and the finished blank is shot out of the gripping jaws into some convenient receptacle. Directly this takes place, the feed fingers 85, 86 immediately rise to such a position, that

the shank of the blank they carry is co-axial with the spindle 11, and the arm 71 carries the fingers 85, 86 toward the spindle, so that the shank of the blank is inserted in the gripping jaws 12. Upon this movement of the fingers ceasing, by the contact of the adjustable stop screw 83 with the forward face of the curved stationary stop 84, the upstanding lug 75 on the sleeve 74 acts against the face of the blank head and pushes the blank into the gripping jaws nearly up to its head as shown at Fig. 8, whereby, when the blank is gripped by the jaws, there is no necessity for any back die to steady it while being turned nor any occasion for any further holding grip while being nicked. The gripping jaws 12 of the spindle 11 are then closed by the sliding sleeve 14, and the feed fingers are drawn away from the jaw-carrying spindle 11, and are caused to rise preparatory to taking another blank from the guide rail 94. The rocking frame 9 is then thrown over into its second position, that is, into the position shown by dotted lines at Fig. 4, which carries the head of the blank against the stationary turning tool 62 in order to effect the primary turning operation, and in this position, as has been explained, the driving belt becomes automatically tensioned and is thus brought into action for revolving the spindle 11, and the rocking frame, with its spindle, is moved slightly forward by the roller 52 acting on the incline 54. When the turning operation is completed the rocking frame 9 moves over to its third position, being during this movement drawn back in the direction of the axis of the shaft 10 by the spring 99. In the third position the blank head is opposite the saw, and the operations which have been described are thus repeated.

What I claim as my invention and desire to secure by patent is:—

1. In a machine for automatically turning, nicking and again turning the heads of screw blanks: the combination with a frame work, a circular nicking saw, means for driving said saw, a stationary turning tool and means for carrying this tool from the frame work, of a rocking frame, a shaft at right angles to the axis of said saw to carry said rocking frame, a jaw-carrying spindle parallel with said shaft carried by said rocking frame, means for rocking said frame into three angular positions, means for feeding a blank into said jaws when said frame is in its first position, means for giving endwise motion to said frame when in its second position to bring the head of the blank into contact with said stationary turning tool, means for revolving said jaw-carrying spindle in said second position to turn the head of said blank, means for giving said rocking frame endwise motion in

its third angular position to carry said blank head against said saw to effect the nicking thereof, and means for releasing and ejecting the finished blank when the rocking frame is again in its first position.

2. In a machine for automatically turning, nicking and again turning the heads of screw blanks: the combination with a frame work, bearings in said frame work, a shaft capable of rocking and endwise motions in said bearings, a frame carried by said shaft, a jaw-carrying spindle carried by said frame, means for rocking said frame into three angular positions, means for revolving said jaw-carrying spindle in the second angular position of said frame, means for closing and opening the jaws carried by said spindle, feed mechanism to insert the shank of a blank into said jaws and means for expelling said blank from said jaws upon the completion of the operations while said rocking frame is in its first angular position, and means for giving endwise motions to said frame in its second angular position, of a stationary turning tool adapted to turn the head of the screw blank in said second angular position of the rocking frame, means for carrying said turning tool from said frame work and for adjusting the tool and means for nicking the head of the blank in said third angular position of the rocking frame.

3. In a machine for automatically turning, nicking and again turning the heads of screw blanks: the combination with a frame work, bearings in said frame work, a shaft capable of rocking and endwise motions in said bearings, a frame carried by said shaft, a jaw-carrying spindle carried by said frame, means for rocking said frame into three angular positions, means for revolving said jaw-carrying spindle in the second angular position of said frame, means for closing and opening the jaws carried by said spindle, feed mechanism to insert the shank of a blank into said jaws and means for expelling said blank from said jaws upon the completion of the operations while said rocking frame is in its first angular position, and means for giving endwise motions to said frame in its third angular position, of a shaft extending at right angles to the axis of said rocking frame, bearings to carry said shaft, a circular nicking saw carried by said shaft, means for adjusting the same parallel with said axis, and means for turning the head of the blank in the second angular position of said rocking frame before and after the nicking operation.

4. In a machine for automatically turning, nicking and again turning the heads of screw blanks: the combination with a frame work, a circular nicking saw, means for driving said saw, a stationary turning tool

and means for carrying said tool from the frame work, of a rocking frame, a shaft extending at right angles to the axis of said saw to carry said rocking frame, means for rocking said frame into three angular positions, a hollow spindle parallel with said shaft carried by said rocking frame, gripping jaws carried by said spindle, a spring to open said jaws, a sliding sleeve on said spindle and a shaped lever within the spindle to close said jaws, means for sliding said sleeve, means for feeding the shank of a blank between said gripping jaws and for ejecting said blank upon the completion of the operations in the first angular position of said rocking frame, means for giving endwise motion to said rocking frame in its second angular position to carry the blank head against said turning tool and in its third position to bring said blank head against said saw to form the nick therein, and means for revolving the spindle in said second position only.

5. In a machine for automatically turning, nicking and again turning the heads of screw blanks: the combination with a frame work, a rocking frame, a shaft carrying said rocking frame, and a jaw carrying spindle parallel with said shaft carried by said rocking frame, of a movable frame, a shaft parallel with the shaft of said rocking frame at the opposite side of the machine, this shaft having bearings in said frame work and slidably supporting one end of said movable frame, said movable frame having eyes at its opposite end to embrace said shaft of the rocking frame, toggle levers connecting said rocking frame with said movable frame, a pivoted arm carried by said movable frame, a roller carried by the free end of said arm, a cam shaft, means for driving this shaft, a cam thereon to act on said roller, and a link connecting said arm with said toggle levers to rock said rocking frame thereby into three angular positions, successively, means for feeding the blank to be operated upon into said jaws when said frame is in its first angular position, means for turning and again turning the head of the blank when said rocking frame is in its second angular position, means for nicking the blank head when the rocking frame is in its third angular position and means for releasing and ejecting the turned and nicked blank when the said rocking frame is again in its first position.

6. In a machine for automatically turning, nicking and again turning the heads of screw blanks: the combination with a hollow jaw-carrying spindle and means for closing and opening the gripping jaws carried by said spindle, of a tube located axially in and carried by said spindle and capable of endwise sliding motions therein, a stop to limit the rearward endwise motion of said tube in said spindle, a circular grooved collar fixed on the

rear end of said sliding tube, a slide, bearings in the frame work to carry said slide, a lever to communicate endwise movements to said slide, a cam to operate said lever, a segmental arm carried by said slide to engage the groove of the collar on said sliding tube, a plunger in said sliding tube to act against the end of the screw blank inserted in said jaws, a stem on said plunger, and a spring on said plunger stem to act between said plunger and the end of said sliding tube, whereby said spring is compressed by the forward sliding motion given to said tube and said plunger is caused to eject said blank when the latter is released by said jaws.

7. In a machine for automatically turning, nicking and again turning the heads of screw blanks: the combination with a frame work, a circular nicking saw, means for driving said saw, a stationary turning tool, means for carrying this tool from the frame work, a rocking frame, an endwise movable shaft extending at right angles to the axis of said saw to carry said rocking frame, a jaw-carrying spindle carried by said rocking frame, means for rocking said frame into successive angular positions, and means for revolving said spindle when said rocking frame is in its head-turning position, of an incline on the frame work, a collar adjustably mounted on the forward end of the shaft of the rocking frame, a roller carried by said collar to interact with said incline to advance said rocking frame when in said head-turning position to bring the head of the revolving blank into contact with the stationary turning tool; a forked lever, a spindle on the frame work on which said lever is pivoted and a cam by which said lever is rocked at proper times; said forked lever being arranged to interact with the rear end of the rocking frame upon its arrival at its nicking position to move said frame endwise to bring the blank head against said saw to effect the nicking thereof, and a spring on said shaft of the rocking frame to return said frame after each of such forward endwise movements.

8. In a machine for automatically turning, nicking and again turning the heads of screw blanks: the combination with a jaw-carrying spindle and means for opening and closing its gripping jaws, of mechanism for feeding headed blanks successively into said gripping jaws, including a two-part lever, a shaft to carry said lever, bearings to carry said shaft permitting the same to have rocking and endwise movements, a sleeve carried at the end of one arm of said two-part lever, a rod adapted to slide in said sleeve in a direction parallel to the axis of said jaw-carrying spindle, a spring to slide the shaft carrying said two-part lever in the direction of said jaw-carrying spindle, means for sliding said shaft in the reverse direction at proper times, a brake-arm on said sleeve of said two-part lever to retain said sliding rod therein in any position, a fixed finger and a pivoted finger at the rear end of said sliding rod, a spring to hold said pivoted finger in contact with said fixed finger, a feed chute having a slotted end through which chute the blanks to be operated upon are passed, spring fingers pivoted to said chute to temporarily retain the lower blank within said slotted end, said fingers on said sliding rod passing into the slot of said chute to receive said lower blank, a stop piece on the frame work of the machine, an adjustable stop screw at the front end of said sliding rod to contact with said stop piece upon the feed traverse of said feed to draw back said sliding rod in said sleeve, a lug on the rear end of said sleeve to contact with the blank head to force the blank into said jaws, and a stud on said sliding rod to contact with said stop piece on the retrograde movement of said sleeve to relocate said sliding rod in said sleeve preparatory to its being rocked to take another blank, substantially as set forth.

In witness whereof I have hereunto set my hand in the presence of two witnesses.

WILLIAM AVERY.

Witnesses:

THOMAS W. ROGERS,
WILLIAM A. MARSHALL.