



(51) International Patent Classification:

A24B 15/16 (2006.01) A61M 15/00 (2006.01)
A24F 47/00 (2006.01) A61M 15/06 (2006.01)
A61M 11/04 (2006.01)

(21) International Application Number:

PCT/US2018/042194

(22) International Filing Date:

14 July 2018 (14.07.2018)

(25) Filing Language:

English

(26) Publication Language:

English

(30) Priority Data:

15/653,398 18 July 2017 (18.07.2017) US

(63) Related by continuation (CON) or continuation-in-part (CIP) to earlier application:

US 15/653,398 (CON)
Filed on 18 July 2017 (18.07.2017)

(72) Inventor; and

(71) Applicant: WHITE, Jackie, L. [US/US]; 4843 River Haven Road, Pffafstown, NC 27040 (US).

(74) Agent: DREMANN, Christopher, C.; Christopher C. Dre-
mann, P.C., 18 Mallard Court, Granite Falls, NC 28630
(US).

(81) Designated States (unless otherwise indicated, for every
kind of national protection available): AE, AG, AL, AM,
AO, AT, AU, AZ, BA, BB, BG, BH, BN, BR, BW, BY, BZ,
CA, CH, CL, CN, CO, CR, CU, CZ, DE, DJ, DK, DM, DO,
DZ, EC, EE, EG, ES, FI, GB, GD, GE, GH, GM, GT, HN,
HR, HU, ID, IL, IN, IR, IS, JO, JP, KE, KG, KH, KN, KP,
KR, KW, KZ, LA, LC, LK, LR, LS, LU, LY, MA, MD, ME,
MG, MK, MN, MW, MX, MY, MZ, NA, NG, NI, NO, NZ,
OM, PA, PE, PG, PH, PL, PT, QA, RO, RS, RU, RW, SA,
SC, SD, SE, SG, SK, SL, SM, ST, SV, SY, TH, TJ, TM, TN,
TR, TT, TZ, UA, UG, US, UZ, VC, VN, ZA, ZM, ZW.

(84) Designated States (unless otherwise indicated, for every
kind of regional protection available): ARIPO (BW, GH,
GM, KE, LR, LS, MW, MZ, NA, RW, SD, SL, ST, SZ, TZ,
UG, ZM, ZW), Eurasian (AM, AZ, BY, KG, KZ, RU, TJ,
TM), European (AL, AT, BE, BG, CH, CY, CZ, DE, DK,
EE, ES, FI, FR, GB, GR, HR, HU, IE, IS, IT, LT, LU, LV,
MC, MK, MT, NL, NO, PL, PT, RO, RS, SE, SI, SK, SM,
TR), OAPI (BF, BJ, CF, CG, CI, CM, GA, GN, GQ, GW,
KM, ML, MR, NE, SN, TD, TG).

(54) Title: PELLET SUBSTRATES FOR VAPORIZING AND DELIVERING AN AEROSOL

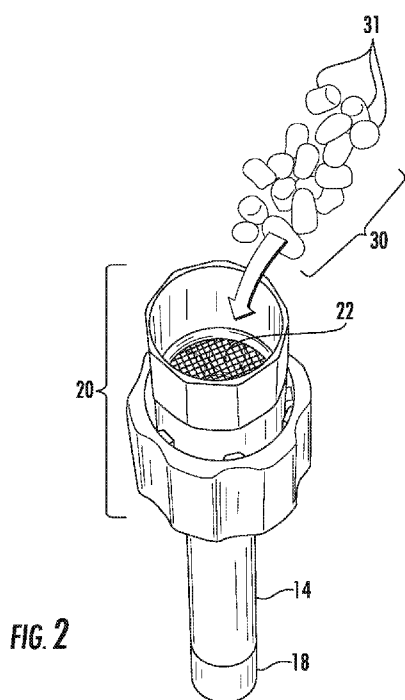

(57) Abstract: Pellet substrates configured for use with a vapor delivery device to vaporize and deliver an aerosol to a user include porous, substantially inert activated carbon and activated alumina pellets that have generally spherical, semi-spherical and/or rounded shapes. The pellet substrates are formed by mixing the pellets together with a liquid solution of an aerosol former admixed with flavoring and/or nicotine, tobacco powder, or tobacco extract such that the liquid solution is absorbed into and/or adsorbed onto the porous structure of the pellets with or without the addition of heat. The pellets may be coated with an inert dry powder, such as calcium carbonate, to better adhere the liquid solution to the porous surfaces of the pellets. Alternatively, or in addition, the pellets may be coated with a mixture of a food grade cellulose gum, such as sodium carboxymethylcellulose (NaCMC), and distilled water to reduce fracturing, cracking, chipping and dusting of the pellet substrates.



Declarations under Rule 4.17:

— *of inventorship (Rule 4.17(iv))*

Published:

— *with international search report (Art. 21(3))*

PELLET SUBSTRATES FOR VAPORIZING AND DELIVERING AN AEROSOL

CROSS-REFERENCE TO RELATED APPLICATION

[0001] This International application claims the benefit of priority to United States Application No. 15/653,398 filed on July 18, 2017, the entire disclosure of which is incorporated herein by reference.

FIELD OF THE INVENTION

[0002] The present invention relates to substrates useful for vaporizing and delivering an aerosol to a user. In exemplary embodiments, the invention is a substrate in the form of a pellet for use with a device configured to vaporize and deliver an aerosol to a patient or a smoker. In exemplary embodiments, the invention is a porous, inert substrate in the form of a pellet adsorbed with an aerosol former and flavoring and/or nicotine, finely-ground tobacco powder, or tobacco extract for use with a “heat not burn” type vaporizer to deliver a combustion-free aerosol to a smoker.

BACKGROUND OF THE INVENTION

[0003] The adverse health risks associated with smoking cigarettes are well known. It is estimated that at least seventy percent (70%) of smokers today desire to reduce the number of cigarettes they smoke, or to quit smoking altogether. Despite the known risks, only about six percent (6%) of smokers report that they were able to quit smoking entirely. The low rate of success is believed to be due to the highly addictive nature of the nicotine present in the tobacco of conventional cigarettes. Nicotine gum and nicotine patches are available for the delivery of nicotine without the harmful carcinogenic by-products of tobacco combustion. Nicotine gum and nicotine patches, however, have proven to be less successful as means for smoking cessation due to their failure to satisfy the hand-to-mouth and inhalation urges of a habitual smoker. In the past few years, nicotine delivery devices in the form of combustion-free electronic cigarettes, also referred to as “smokeless cigarettes,” “e-cigarettes,” and “digital vapor cigarettes,” as well as vape pens and vaporizers have been developed and introduced to the public. These devices operate on the “heat-not-burn” principle, and thus, are believed to eliminate the harmful carcinogenic by-products of tobacco combustion.

[0004] Popular brands of electronic cigarettes include BLU ECIGS® offered by Lorillard Technologies, Inc. of Greensboro, North Carolina, USA, VUSE® offered by Reynolds Innovations, Inc. of Winston-Salem, North Carolina, USA, MARK 10™ offered by Phillip Morris, Inc. of Richmond, Virginia, USA, and NJOY® offered by NJOY, Inc. of Scottsdale, Arizona, USA. Popular brands of vape pens and vaporizers (collectively “vaporizers”) include FIREFLY® offered by Firefly Company of San Francisco, California, USA, Matrix offered by Mig Vapor of Pompano Beach, Florida, USA, PAX® offered by PAX Labs, Inc. of San Francisco, California, USA, V2Pro offered by VMR Products, LLC of Miami, Florida, USA, HAZE® V3 offered by Haze Industries, Inc. of Atlanta Georgia, USA, Ploom™ and Ploom TECH™ offered by Japan Tobacco Inc. of Tokyo, Japan, and the Iolite® WISPR® offered by Ogelsby & Butler of Carlow, Ireland.

[0005] Each of the aforementioned commercially available electronic cigarettes and vaporizers replicates the hand-to-mouth and inhalation experiences of a traditional tobacco cigarette desired by smokers. Electronic cigarettes and vaporizers can also satisfy a smoker’s craving for addictive nicotine without exposing the smoker to the carcinogenic by-products produced by the combustion of tobacco, and without exposing by-standers to harmful second-hand smoke. As a result, electronic cigarettes and vaporizers are credited with providing a healthier nicotine delivery option to smokers, as well as a healthy environment for by-standers, by at least significantly reducing, and potentially eliminating, the harmful effects of the carcinogens present in the tobacco smoke that would otherwise be produced and dispersed by the combustion of tobacco with a conventional tobacco cigarette.

[0006] Conventional tobacco cigarettes are made of a combustible material that is ignited with a flame to cause the tobacco to burn. Burning tobacco releases an aerosol tobacco smoke containing nicotine that is inhaled by the smoker to deliver the nicotine to the lungs. Electronic cigarettes, on the other hand, heat a liquid, commonly referred to as “e-liquid,” containing an aerosol former, such as glycerin, vegetable glycerin and/or propylene glycol, admixed with flavoring and/or nicotine. The heat causes the e-liquid to produce an aerosol, commonly referred to as a “vapor” or “vape,” that is inhaled by the smoker to deliver the flavoring and/or nicotine to the lungs. Most of the current electronic cigarettes include a battery energy source, an atomizer and a hollow, re-fillable or expendable cartridge that contains the e-liquid. Due to the frequency required to re-fill or replace the cartridge, an advanced type of electronic cigarette has been developed that combines the atomizer and the

e-liquid cartridge into a single “cartomizer” electrically connected to the battery that allows for a greater period of time between re-fill or replacement.

[0007] The vaporization process is initiated by the smoker inhaling on a mouthpiece, or alternatively, by the smoker depressing a manual switch that activates the atomizer or cartomizer. The atomizer heats the e-liquid to cause the aerosol former to produce an inhalable aerosol containing the flavoring and/or nicotine. The aerosol is inhaled through the mouthpiece of the device to deliver the flavoring and/or nicotine to the lungs of the smoker. The smoker then exhales the residual aerosol vapor absent the harmful carcinogenic by-products of tobacco combustion. Vaporizers operate similarly to electronic cigarettes with the exception that most vaporizers utilize dry tobacco material as the substrate to be heated to release the aerosol containing nicotine that is vaporized and delivered to the smoker. Vaporizers are also commonly used with other dry plant (e.g., herb) material as the substrate, for example coffee, tea and marijuana.

[0008] Despite the reduced health risks, there remain certain disadvantages with the electronic cigarette devices that are currently available. For example, the e-liquid typically contains a volatile solution of propylene glycol, vegetable glycerin (VG), glycerin and/or polyethylene glycol 400 (PEG400) admixed with concentrated flavoring and/or a highly variable concentration of nicotine. Certain e-liquid solutions have been found to still contain known cancer-causing agents, referred to as tobacco-specific nitrosamines (TSNAs), as well as tobacco-specific impurities, such as anabasine, myosmine, and β -nicotine. In fact, a recent study by the Food and Drug Administration (FDA) detected diethylene glycol, a poisonous and hygroscopic liquid commonly used in anti-freeze solutions, in a commercial e-liquid and measurable levels of nicotine in another commercial e-liquid that claimed to be nicotine-free.

[0009] These findings are particularly disturbing since the cartridges and cartomizers of electronic cigarettes that contain the e-liquid are inherently susceptible to leakage and/or breakage as a result of their small size and relative fragility. As a result, there exists a danger that a cartridge or cartomizer could leak or break, and thereby cause a user to directly inhale a harmful dosage of the e-liquid solution prior to vaporization. It is also possible for the e-liquid solution leaking from the cartridge or cartomizer to damage the electronics and/or corrode the battery of the vaporizer. Furthermore, the glycerin and/or propylene glycol aerosol former in the e-liquid is combustible, and thus, could ignite and cause a fire if the e-liquid solution comes into contact with an ignition source.

[0010] Certain disadvantages likewise exist with the vaporizers that are currently available. As previously mentioned, vaporizers typically utilize a dry plant material as the substrate that is heated to form the vapor to be delivered to the user in the form of an aerosol. The dry plant material is placed into a combination heating and aerosolizing (vaporizing) chamber, commonly referred to as the “oven.” For the best results, it is essential that the dry plant material is finely ground and contains very little moisture, preferably less than about fifteen percent (15%). Accordingly, additional equipment, namely a fine particle grinder and a dryer are needed for optimal vaping. Furthermore, vaporizers that operate on the principle of conduction heating produce better vapor when a finely ground dry plant material is more tightly packed into the oven. Conversely, vaporizers that operate on the principle of convection heating produce better vapor when the unground dry plant material is more loosely packed into the oven. Regardless, the processes of grinding, drying and/or packing the dry plant material into the oven of the vaporizer, as well as subsequently removing the dry plant material residue and cleaning the oven, can be difficult, time consuming and variable, thereby making a consistently enjoyable vaping experience less likely.

[0011] Accordingly, an improved substrate for use with a vapor delivery device configured for vaporizing and delivering an aerosol to a patient or a smoker is needed. Furthermore, a substrate for vaporizing and delivering an aerosol is needed that is safe, relatively easy and convenient to use. In particular, a substrate for vaporizing and delivering an aerosol containing aerosol former and flavoring and/or nicotine, finely-ground tobacco powder, or tobacco extract is desired that overcomes the problems, deficiencies and disadvantages of the electronic cigarettes and vaporizers that are currently available. Specifically, a porous, inert substrate for vaporizing and delivering an aerosol to a smoker is needed that eliminates the known risks of producing harmful carcinogenic by-products, inhaling an e-liquid solution, and damaging the battery or electronics of the vapor delivery device or potentially causing a fire in the event of an e-liquid leak. Such a substrate should also not require the use of additional equipment or excessive time to prepare the substrate in the vapor delivery device or to subsequently clean the vapor delivery device so as to create a consistently enjoyable vaping experience.

[0012] As used herein, the term “aerosol” means a colloidal system of solid and/or liquid particles dispersed and suspended in a gas, such as smoke or fog. The term “aerosol” is intended to include vapors, gases, fine particle suspensions, and the like, both visible and

invisible. As so defined, the term "aerosol" specifically includes any pharmacologically or physiologically active agents and any desired additive, such as an aerosol former, flavoring, nicotine and/or an extract, irrespective of whether the mixture produces a visible aerosol. In exemplary embodiments of the invention shown and described herein, the aerosol is generated by a heat source acting upon a substrate adsorbed with an aerosol former. In specific exemplary embodiments, the aerosol former is admixed with flavoring and/or nicotine, finely-ground tobacco powder, or tobacco extract in a manner consistent with the invention. As used herein, the term "in heat-conducting relation" is intended to mean an arrangement whereby heat is transferred by conduction or convection to a thermally conductive component, such as a heat conductor or a substrate, from a heat generating source, such as a heating element. A heat-conducting relation can be achieved by locating the thermally conductive component in direct physical contact or in close proximity to the heat generating source, or alternatively, merely in fluid (e.g., air) communication with the heat generating source.

BRIEF DESCRIPTION OF THE DRAWING FIGURES

[0013] These and other features, aspects and advantages of the invention are better understood and appreciated when considered in light of the following detailed description of the invention with reference to the accompanying drawings.

[0014] FIG. 1 is an environmental perspective view showing a typical vapor delivery device suitable for use with pellet substrates for vaporizing and delivering an aerosol according to the present invention.

[0015] FIG. 2 is an environmental perspective view showing a heating and vaporizing chamber of the vapor delivery device of FIG. 1 being filled with pellet substrates for vaporizing and delivering an aerosol according to the present invention.

[0016] FIG. 3 is schematic flowchart depicting exemplary embodiments of pellet substrates for vaporizing and delivering an aerosol according to the present invention.

DETAILED DESCRIPTION OF EXEMPLARY EMBODIMENTS OF THE INVENTION

[0017] The invention will be described more fully hereinafter with reference to the accompanying drawing figures in which various exemplary embodiments are shown.

However, it is to be understood that the invention may be embodied in numerous different forms and should not be construed as limited to the exemplary embodiments set forth herein. Exemplary embodiments of the invention are provided herein so that this disclosure will both completely and accurately convey the broadest scope of the invention, as well as enable one of ordinary skill in the art to make, use and practice the invention without undue experimentation. Like reference characters in the written description and accompanying drawing figures refer to the same or similar parts, elements, assemblies, subassemblies, systems and the like of the invention.

[0018] The exemplary embodiments provided herein show and describe pellet substrates for vaporizing and delivering an aerosol to a user, such as a patient or a smoker. By way of example and not limitation such pellet substrates are usable with a vapor delivery device to vaporize and deliver an aerosol containing a therapeutic drug to a patient, or similarly, an aerosol containing flavoring and/or nicotine to a smoker. As used herein, the term “aerosol” is intended to include vapors, gases, fine suspended particles, and the like, both visible and invisible. As so defined, “aerosol” specifically includes any pharmacologically or physiologically active agents and any desired additives, such as an aerosol former, flavoring, nicotine and/or an extract, irrespective of whether they produce a visible aerosol. Ideally, the aerosol has a density consistent with cigarette smoke and a small particle size on the order of about 0.2-3.0 microns. As used herein, the term “aerosol drug” refers to a therapeutic drug in the form of an aerosol available for delivery to a patient for use in inhalation therapy. Similarly, the term “aerosol nicotine” refers to flavoring and/or nicotine in the form of an aerosol available for delivery to a smoker via a vapor delivery device, and in particular, a combustion-free “heat-not-burn” electronic cigarette, vape pen, vaporizer or the like.

[0019] The aerosol, and more specifically the aerosol drug or the aerosol nicotine, is preferably produced by an aerosol former that is activated from heat generated by a heating element and conducted by a heat conductor. In certain instances, the heat generator (or heating element) and the heat conductor may be one and the same component. A vapor delivery device suitable for use with pellet substrates for vaporizing and delivering an aerosol according to the present invention provides a portable, effective, convenient, safe and simple to use means for reliably and repeatedly vaporizing and delivering a wide variety of pharmacologically or physiologically active agents to a user in the form of an aerosol. Such devices are particularly well suited and useful for vaporizing and delivering a therapeutic

drug in the form of an aerosol drug to a patient, or alternatively, flavoring and/or nicotine in the form of aerosol nicotine to a smoker.

[0020] A vapor delivery device, indicated generally by reference character **10**, for use with pellet substrates for vaporizing and delivering an aerosol according to the present invention is shown in FIG. 1. By way of example and not limitation, a suitable vapor delivery device **10** is commercially known as Iolite® WISPR® and is available from Ogelsby & Butler of Carlow, Ireland. The device **10** comprises a housing **12**, a vapor delivery chamber **14** extending outwardly from the housing **12** in the form of a generally hollow tube or stem, and an actuator **16** for activating the device between an inactive mode, a heating mode and a subsequent vapor delivery mode in a known manner. The device **10** further comprises a removable mouthpiece (not shown) that is attached to the free end **18** of the vapor delivery chamber **14** for delivering an aerosol containing flavoring and/or nicotine to a smoker. FIG. 2 shows a heating and vaporizing chamber **20** of the vapor delivery device **10**. The heating and vaporizing chamber **20** is also commonly referred to as the “oven” of the device **10**. The oven **20** is constructed so as to be in fluid (i.e., air) communication with the vapor delivery chamber **14** and is removably disposed within the housing **12** of the device **10**.

[0021] In FIG. 2, the oven **20** is shown removed from the housing **12** of the vapor delivery device **10** and in an inverted position for being filled with one or more substrates, indicated generally by reference character **30**, comprising material for smoking. Consequently, the heating and vaporizing chamber **20** additionally functions as a substrate holder for the substrates **30**. The oven **20** comprises a fine mesh screen **22** for preventing the substrates **30** from being drawn by inhalation of the user through the vapor delivery chamber **14** into the mouthpiece. The vapor delivery device **10** may further comprise a heat conductor (not shown) disposed within the housing **12** for preventing the substrates **30** from coming into direct contact with a heating element (not shown) of the device **10**. The heating element may be powered by an electric (e.g., battery) or a combustible gas (e.g., butane) power source in a known manner and as further shown and described in United States Patent No. 9,016,274 B1, the entire disclosure of which is incorporated herein by reference. Heating of the substrates **30** may occur as a result of conduction heating and/or convection heating depending on the particular type of vapor delivery device **10**.

[0022] Substrates **30** are formed of a material that conforms to the size and shape of the heating and vaporizing chamber (i.e., oven) **20** of the vapor delivery device **10**. As

previously mentioned, a device **10** suitable for use with the substrates **30** is the Iolite® WISPR® vaporizer commercially available from Ogelsby & Butler of Carlow, Ireland. Other suitable devices include the handheld Iolite® vaporizer, likewise available from Ogelsby & Butler, the PAX® and PAX 2® handheld vaporizers available from PAX Labs, Inc. of San Francisco, California, USA, the VOLCANO desktop vaporizer available from the Storz & Bickel Company of Tuttlingen, Germany, the FIREFLY® handheld vaporizer available from Firefly Company of San Francisco, California, USA, the Ploom and Ploom TECH vaporizers available from Japan Tobacco Inc. of Tokyo, Japan, and others.

[0023] Each of the aforementioned vapor delivery devices has a heating and vaporizing chamber that may be configured to receive the substrates **30**. In particular, the substrates **30** can be easily deposited, commonly referred to as “loaded,” into the heating and vaporizing chamber **20**, for example by pouring or funneling. In addition, the substrates **30** can be easily and readily removed after use without leaving an unwanted residue. In that regard, it has been determined that a substrate having a generally spherical or semi-spherical shape, or at least a generally rounded shape, is particularly advantageous for filling and emptying the heating and vaporizing chambers of most vapor delivery devices. Furthermore, a substrate having a generally spherical, semi-spherical or generally rounded shape provides additional surface area for volatilizing (vaporizing) an aerosol former from the substrate to produce an aerosol containing flavoring and/or nicotine to be delivered to the smoker. For purposes of this written description of exemplary embodiments of the invention, substrates having the aforementioned generally spherical, semi-spherical or generally rounded shapes are referred to as “pellet-shaped” or “pellet” substrates.

[0024] Substrates **30** comprise at least one, and preferably, a plurality of pellet substrates **31** formed of a porous, substantially inert substance exhibiting a relatively high capability and capacity for absorption. The pellet substrates **31** preferably have an adsorption surface area over about 200 m²/g and up to about 3000 m²/g. In the exemplary embodiments disclosed herein, the pellet substrates **31** are formed of activated carbon or activated alumina. However, any other porous, inert substance having absorption capability and capacity may be utilized. However, in an advantageous embodiment, the pellet substrates **31** are formed of granular activated carbon manufactured from high quality crushed or ground coconut husks or shells, commercially referred to as coconut granular activated carbon (“coconut GAC”) or coconut activated carbon. Suitable pellet substrates **31** include, but are not limited to coconut

granular activated carbon commercially available from Calgon Carbon Corporation of Moon Township, Pennsylvania, USA, such as coconut granular activated carbon OLC, coconut granular activated carbon OVC, and coconut activated carbon 208C. Other suitable granular activated carbon pellet substrates **31** are commercially available from Cabot Corporation of Boston, Massachusetts, USA under the trade name NORIT[®] GCN. The OLC, OLV and GCN granular activated carbon and the 208C activated carbon pellets are available in a variety of mesh sizes, and thus, surface areas. Other pellet substrates **31** comprising granular activated carbon manufactured from other substances having high absorption capability, such as charcoal, coal, coke and wood, are also suitable for use with the present invention. Suitable activated carbon substances may contain some crystalline silica. However, activated carbon and activated alumina substances suitable for use with the present invention should be essentially free of carcinogenic components or compounds. Regardless, the pellet substrates **31** are produced from a porous, substantially inert substance that is processed to have relatively small, low-volume pores so as to increase the surface area available for adsorption. As used herein, the term “adsorption” is intended to have the ordinary and customary meaning of “the adhesion of atoms, ions or molecules from a gas, liquid or dissolved solid to a surface.” Similarly, the term “absorption” is intended to have its ordinary and customary meaning of “the process or action by which one thing or substance absorbs another.”

[0025] Pellet substrates **31** according to the present invention can be formed by several different methods and may be formed from numerous different substrate materials and/or mixtures of substrate materials. Exemplary embodiments of suitable methods and suitable materials are disclosed and shown herein. However, it should be understood and appreciated equivalent methods and substrate materials, as well as others not specifically disclosed herein, are intended to be encompassed by the intended broad scope of the present invention. By way of example and not limitation, suitable materials for forming the pellet substrates **31** include granular activated carbon (GAC), coconut granular activated carbon, coconut activated carbon, charcoal, coal, coke or wood activated carbon, cellulose-based, starch-based and sugar-based substances, and powders, such as calcium carbonate, alumina, pure carbon, etc. In the particular examples provided herein, the substrate pellets **31** generally comprise activated alumina and activated carbon. As used herein, the terms “activated alumina” and “activated carbon” are intended to include any form of alumina or carbon that has been processed to have small, low-volume pores that increase the surface area available for adsorption. An example of activated carbon is charcoal that has been treated, such as by

heating, to increase its adsorptive power. Another example of activated carbon is coconut shell granulated activated charcoal (also referred to as “coconut shell activated carbon”) that has been heated in the presence of steam so as to create pores that increase its adsorption. If necessary, the pellet substrates **31** may further comprise a food gum binder to provide increased adhesion of additives, as will be described. Suitable examples of activated alumina may be made from aluminum oxide (Al_2O_3).

[0026] An exemplary embodiment of a method for forming the pellet substrates **31** comprises a first step of combining the activated alumina or activated carbon with a liquid solution comprising an aerosol former admixed with flavoring and/or nicotine, tobacco powder, or nicotine extract. In a second step, the liquid solution is allowed to be adsorbed into the pellet substrates **31** over a suitable period of time. In an optional third step, heat greater than the ambient temperature may be applied to accelerate the adsorption process without causing thermal degradation of the flavoring and/or nicotine of the liquid solution, or other adverse effects. In yet another optional fourth step, the mixture of pellet substrates **31** and liquid solution may be coated with a dry, solid coating of an inert powder, such as calcium carbonate, aluminum oxide, alumina, carbon or the like, as well as combinations thereof. The inert powder of the coating serves to promote adhesion of the liquid solution to the exposed surfaces of the pellet substrates **31**, and thereby provides a relatively smooth, dry surface on the pellet substrates **31**. As a result, the pellet substrates **31** flow with reduced friction relative to one another for easily and readily filling and removing the pellet substrates **31** from the heating and vaporizing chamber (i.e., oven) **20** of the vapor delivery device **10**.

[0027] In another exemplary embodiment of a method for forming the pellet substrates **31**, the activated alumina or activated carbon is coated with a liquid mixture comprising a low viscosity food grade cellulose gum, such as sodium carboxymethylcellulose (NaCMC) type 7LF available from Ashland Inc. of Covington, Kentucky, USA under the trade name Aqualon® CMC-7LF, and distilled water. The liquid mixture is allowed to absorb into the porous structure of the activated alumina or activated carbon and to adsorb onto the exposed surfaces of the activated alumina or activated carbon. The concentration of the liquid mixture is preferably between about 0.01% and about 5.0%. More preferably, the concentration of the liquid mixture is between about 0.01% and about 1.0%. In the particular examples provided herein, 0.2 grams of Aqualon® CMC-7LF was mixed with 100 grams of distilled water, resulting in a concentration of 0.2%. The liquid solution was applied to the exposed

surfaces of activated alumina and activated carbon granules and allowed to be absorbed into the porous structure. The remaining moisture was then removed by drying the coated pellet substrates **31** in a heated environment, such as a heat exchanger or a heat chamber, at a temperature sufficient to remove the excess moisture in a reasonable period of time without any adverse effect to the pellet substrates **31**. The temperature of the heated environment should preferably be between about 100°F and about 250°F.

[0028] The sodium carboxymethylcellulose (NaCMC) coating serves to eliminate or substantially reduce fracturing, cracking, chipping and/or dusting of the pellet substrates **31** as compared to activated alumina and activated carbon pellets that have not been coated. Surprisingly, it has been found that coating the activated carbon and activated alumina pellets with the mixture of NaCMC and distilled water does not adversely affect adsorption of the liquid solution comprising an aerosol former and at least one of a flavoring and/or nicotine, a tobacco powder, and a tobacco extract, such as an e-liquid. In fact, it has been confirmed that the coconut-based granular activated carbon (GAC) pellets with a sodium carboxymethylcellulose (NaCMC) coating typically adsorb at a ratio of 2 parts carbon to 1 part e-liquid solution, which is substantially the same as has been obtained with the uncoated activated carbon pellets. Other film-forming food grade gums, such as xanthan, guar, alginates, starches, locust beans, acacia, etc. are expected to provide the same or similar benefit. Regardless, pellet substrates **31** that have been coated with a film-forming food grade gum, and in particular NaCMC, are referred to herein as “coated” or “treated” substrates. Pellet substrates **31** that are not coated with a film-forming food grade gum, and in particular NaCMC, are referred to herein as “uncoated” or “untreated” substrates.

[0029] As previously mentioned, pellet substrates **31** according to the present invention may further comprise pharmacologically or physiologically active agents and any desired additive, such as a therapeutic drug, a flavoring, a powder, an extract or nicotine. FIG. 3 is a schematic flowchart depicting exemplary embodiments **40** of pellet substrates **31** configured for use with a vapor delivery device **10** for vaporizing and delivering an aerosol according to the present invention. As previously described, the pellet substrates **31** comprise a porous substrate **42** formed from a substantially inert material, such as activated alumina or activated carbon. The porous, inert substrate **42** is either a treated substrate **44** treated in the manner described herein with a film-forming food grade gum coating, such as NaCMC, or alternatively, is an untreated substrate **45**. Regardless, the treated substrate **44** or the

untreated substrate **45** is further mixed with a liquid solution comprising an aerosol former with flavoring and/or nicotine **46**, an aerosol former with tobacco powder **47**, or an aerosol former with tobacco extract **48**. Consequently, combination of pellet substrates **31** according to the present invention comprise at least three (3) types of treated pellet substrates (i.e., **44/46**; **44/47**; **44/48**) and at least three (3) types of untreated pellet substrates (i.e., **45/46**; **45/47**; **45/48**). Particular examples of combinations and types of pellet substrates **31** are provided herein for purposes of explanation only and not by way of limitation.

[0030] The following specific examples of pellet substrates **31** have been found to be particularly well suited for use with a vapor delivery device **10** to vaporize and deliver an aerosol to a user, such as a patient or a smoker, in the manner contemplated by the present invention using the aforementioned methods comprising the process steps of mixing, coating and/or applying, absorbing and/or adsorbing and heating. The specific examples of pellet substrates **31** have been grouped together in the following Tables 1-16 by common composition and a variable component for purposes of ready comparison.

TABLE 1

Example No.	Porous Inert Substrate	Aerosol Former +
1	20g Coconut GAC (12X30)	5g (70VG/30PG)
2	20g Coconut GAC (12X30)	10g (70VG/30PG) 1g CaCO ₃ Coating

[0031] The pellet substrates **31** of Example 1 were formed by mixing in a glass flask about 20 grams by weight of Calgon Carbon coconut granular activated carbon (GAC) OLC 12X30 mesh pellets together with about 5 grams by weight of a liquid solution containing an aerosol former consisting of about 70% vegetable glycerin (VG) and about 30% propylene glycol (PG). The mixture was then heated to a temperature of between about 150°F and about 200°F for a time greater than about 4 hours by applying flame heat to the bottom of the flask. The liquid solution was rapidly adsorbed into the coconut GAC pellets. The pellets were allowed to cool and about 300 mg of the pellet substrates **31** were loaded into a vapor delivery device **10**, namely an Iolite[®] butane heat vaporizer. The vaporizer was operated according to the manufacturer's specifications and the vaporizer delivered a substantial amount of aerosol with no appreciable off taste such that "good" taste was achieved.

[0032] The pellet substrates **31** of Example 2 were formed by mixing in a glass flask about 20 grams by weight of Calgon Carbon coconut granular activated carbon (GAC) OLC 12X30 mesh pellets together with about 10 grams by weight of a liquid solution containing an aerosol former consisting of about 70% vegetable glycerin (VG) and about 30% propylene glycol (PG). The mixture was then heated to a temperature of between about 150°F and about 200°F for about 1 hour by applying flame heat to the bottom of the flask. A residual amount of the liquid solution remained on the surface of the pellets. About 1 gram of an inert dry powder coating, namely calcium carbonate, was applied to the surface of the pellets so that the liquid solution was adsorbed into the porous pellets over time. The pellets were allowed to cool and about 600 mg of the pellet substrates **31** were loaded into a vapor delivery device **10**, namely an Iolite® butane heat vaporizer. The vaporizer was operated according to the manufacturer's specifications and very good aerosol delivery with no appreciable off taste was achieved.

[0033] The foregoing examples of pellet substrate **31** demonstrated the efficacy of a liquid solution containing an aerosol former being adsorbed into pellets manufactured from coconut granular activated carbon (GAC). The following examples of pellet substrates **31** demonstrate the use of a liquid solution comprising an e-liquid containing an aerosol former admixed with nicotine and/or flavoring that is adsorbed into coconut granular activated carbon (GAC) pellets of various mesh sizes.

TABLE 2

Example No.	Porous Inert Substrate	Aerosol Former +
3	20g Coconut GAC (12X30)	10g (70VG/30PG) Menthol Flavoring 1% Nicotine 0.5g CaCO ₃ Coating
4	20g Coconut GAC (12X30) w/ 16 Mesh Screen	10g (70VG/30PG) Menthol Flavoring 1% Nicotine
5	40g Coconut GAC (6X12)	20g (70VG/30PG) Menthol Flavoring 1% Nicotine

[0034] The pellet substrates **31** of Example 3 were formed by mixing about 20 grams by weight of Calgon Carbon coconut granular activated carbon (GAC) OLC 12X30 mesh pellets together with about 10 grams by weight of an e-liquid solution containing an aerosol former consisting of about 70% vegetable glycerin (VG) and about 30% propylene glycol admixed with menthol flavoring and about 1% nicotine. A residual amount of the e-liquid solution remained on the surface of the pellets. About 0.5 grams of an inert dry powder coating, namely calcium carbonate, was applied to the surface of the pellet substrates **31** so that the liquid solution was adsorbed into the pellet substrates over time.

[0035] The pellet substrates **31** of Example 4 were formed by mixing the remaining portion of about 20 grams by weight of Calgon Carbon coconut granular activated carbon (GAC) OLC 12X30 mesh pellets screened through a 16 mesh screen together with about 10 grams by weight of an e-liquid solution containing an aerosol former consisting of about 70% vegetable glycerin (VG) and about 30% propylene glycol admixed with menthol flavoring and about 1% nicotine. The e-liquid solution was then allowed to be adsorbed into the pellets over time.

[0036] The pellet substrates **31** of Example 5 were formed by mixing about 40 grams by weight of Calgon Carbon coconut granular activated carbon (GAC) 208C 6X12 mesh pellets together with about 20 grams by weight of an e-liquid solution containing an aerosol former consisting of about 70% vegetable glycerin (VG) and about 30% propylene glycol (PG) admixed with menthol flavoring and about 1% nicotine. The mixture was then heated at about 48°C for about 6 hours to aid adsorption of the e-liquid solution into the pellets. The pellets were allowed to cool and about 200 mg of the pellet substrates **31** were loaded into a vapor delivery device **10**, namely an Iolite[®] butane heat vaporizer. The vaporizer was operated according to the manufacturer's specifications and very good aerosol delivery with no appreciable off taste was achieved.

TABLE 3

Example No.	Porous Inert Substrate	Aerosol Former +
6	14g Coconut GAC (8X16)	6g (100PG)
7	14g Coconut GAC (8X16)	6g (70VG/30PG)
8	14g Coconut GAC (8X16)	6g (100VG)

[0037] The pellet substrates **31** of Example 6 were formed by mixing about 14 grams by weight of Cabot Corporation coconut granular activated carbon (GAC) NORIT® GCN 816G 8X16 mesh pellets together with about 6 grams by weight of a liquid solution containing an aerosol former consisting of about 100% propylene glycol (PG).

[0038] The pellet substrates **31** of Example 7 were formed by mixing about 14 grams by weight of Cabot Corporation coconut granular activated carbon (GAC) NORIT® GCN 816G 8X16 mesh pellets together with about 6 grams by weight of a liquid solution containing an aerosol former consisting of about 70% vegetable glycerin (VG) and about 30% propylene glycol (PG).

[0039] The pellet substrates **31** of Example 8 were formed by mixing about 14 grams by weight of Cabot Corporation coconut granular activated carbon (GAC) NORIT® GCN 816G 8X16 mesh pellets together with about 6 grams by weight of a liquid solution containing an aerosol former consisting of about 100% vegetable glycerin (VG).

TABLE 4

Example No.	Porous Inert Substrate	Aerosol Former +
9	30g Coconut GAC (8X16)	15g (70VG/30PG) 3% Menthol Flavoring
10	30g Coconut GAC (8X16)	15g (70VG/30PG) 3% Menthol Flavoring 0.6% Nicotine
11	30g Coconut GAC (8X16)	15g (70VG/30PG) 3% Menthol Flavoring 1.2% Nicotine
12	30g Coconut GAC (8X16)	15g (70VG/30PG) 3% Menthol Flavoring 2.4% Nicotine

[0040] The pellet substrates **31** of Example 9 were formed by mixing about 30 grams by weight of Cabot Corporation coconut granular activated carbon (GAC) NORIT® GCN 816G 8X16 mesh pellets together with about 15 grams by weight of an e-liquid solution containing

an aerosol former consisting of about 70% vegetable glycerin (VG) and about 30% propylene glycol (PG) admixed with menthol flavoring at about 3%.

[0041] The pellet substrates **31** of Example 10 were formed by mixing about 30 grams by weight of Cabot Corporation coconut granular activated carbon (GAC) NORIT[®] GCN 816G 8X16 mesh pellets together with about 15 grams by weight of an e-liquid solution containing an aerosol former consisting of about 70% vegetable glycerin (VG) and about 30% propylene glycol (PG) admixed with about 3% menthol flavoring and 0.6% nicotine.

[0042] The pellet substrates **31** of Example 11 were formed by mixing about 30 grams by weight of Cabot Corporation coconut granular activated carbon (GAC) NORIT[®] GCN 816G 8X16 mesh pellets together with about 15 grams by weight of an e-liquid solution containing an aerosol former consisting of about 70% vegetable glycerin (VG) and about 30% propylene glycol (PG) admixed with about 3% menthol flavoring and 1.2% nicotine.

[0043] The pellet substrates **31** of Example 12 were formed by mixing about 30 grams by weight of Cabot Corporation coconut granular activated carbon (GAC) NORIT[®] GCN 816G 8X16 mesh pellets together with about 15 grams by weight of an e-liquid solution containing an aerosol former consisting of about 70% vegetable glycerin (VG) and about 30% propylene glycol (PG) admixed with about 3% menthol flavoring and 2.4% nicotine.

TABLE 5

Example No.	Porous Inert Substrate	Aerosol Former +
13	30g Coconut GAC (8X16)	15g (70VG/30PG) 4% Tobacco Flavoring
14	30g Coconut GAC (8X16)	15g (70VG/30PG) 4% Tobacco Flavoring 0.6% Nicotine
15	30g Coconut GAC (8X16)	15g (70VG/30PG) 4% Tobacco Flavoring 1.2% Nicotine
16	30g Coconut GAC (8X16)	15g (70VG/30PG) 4% Tobacco Flavoring 2.4% Nicotine

[0044] The pellet substrates **31** of Example 13 were formed by mixing about 30 grams by weight of Cabot Corporation coconut granular activated carbon (GAC) NORIT[®] GCN 816G 8X16 mesh pellets together with about 15 grams by weight of an e-liquid solution containing an aerosol former consisting of about 70% vegetable glycerin (VG) and about 30% propylene glycol (PG) admixed with tobacco flavoring at about 4%.

[0045] The pellet substrates **31** of Example 14 were formed by mixing about 30 grams by weight of Cabot Corporation coconut granular activated carbon (GAC) NORIT[®] GCN 816G 8X16 mesh pellets together with about 15 grams by weight of an e-liquid solution containing an aerosol former consisting of about 70% vegetable glycerin (VG) and about 30% propylene glycol (PG) admixed with tobacco flavoring at about 4% and nicotine at about 0.6%.

[0046] The pellet substrates **31** of Example 15 were formed by mixing about 30 grams by weight of Cabot Corporation coconut granular activated carbon (GAC) NORIT[®] GCN 816G 8X16 mesh pellets together with about 15 grams by weight of an e-liquid solution containing an aerosol former consisting of about 70% vegetable glycerin (VG) and about 30% propylene glycol (PG) admixed with tobacco flavoring at about 4% and nicotine at about 1.2%.

[0047] The pellet substrates **31** of Example 16 were formed by mixing about 30 grams by weight of Cabot Corporation coconut granular activated carbon (GAC) NORIT[®] GCN 816G 8X16 mesh pellets together with about 15 grams by weight of an e-liquid solution containing an aerosol former consisting of about 70% vegetable glycerin (VG) and about 30% propylene glycol (PG) admixed with tobacco flavoring at about 4% and nicotine at about 2.4%.

TABLE 6

Example No.	Porous Inert Substrate	Aerosol Former +
17	15g Coconut GAC (8X16)	7.5g (70VG/30PG) 5% Tobacco Flavoring 1.2% Nicotine
18	15g Coconut GAC (8X16)	7.5g (70VG/30PG) 10% Tobacco Flavoring 1.2% Nicotine
19	15g Coconut GAC (8X16)	7.5g (70VG/30PG) 20% Tobacco Flavoring 1.2% Nicotine

[0048] The pellet substrates **31** of Example 17 were formed by mixing about 15 grams by weight of Cabot Corporation coconut granular activated carbon (GAC) NORIT[®] GCN 816G 8X16 mesh pellets together with about 7.5 grams by weight of an e-liquid solution containing an aerosol former consisting of about 70% vegetable glycerin (VG) and about 30% propylene glycol (PG) admixed with tobacco flavoring at about 5% and nicotine at about 1.2%.

[0049] The pellet substrates **31** of Example 18 were formed by mixing about 15 grams by weight of Cabot Corporation coconut granular activated carbon (GAC) NORIT[®] GCN 816G 8X16 mesh pellets together with about 7.5 grams by weight of an e-liquid solution containing an aerosol former consisting of about 70% vegetable glycerin (VG) and about 30% propylene glycol (PG) admixed with tobacco flavoring at about 10% and nicotine at about 1.2%.

[0050] The pellet substrates **31** of Example 19 were formed by mixing about 15 grams by weight of Cabot Corporation coconut granular activated carbon (GAC) NORIT[®] GCN 816G 8X16 mesh pellets together with about 7.5 grams by weight of an e-liquid solution containing an aerosol former consisting of about 70% vegetable glycerin (VG) and about 30% propylene glycol (PG) admixed with tobacco flavoring at about 20% and nicotine at about 1.2%.

TABLE 7

Example No.	Porous Inert Substrate	Aerosol Former +
20	15g Coconut GAC (8X16)	7.5g (70VG/30PG) 3% Menthol Flavoring 1.2% Nicotine
21	15g Coconut GAC (6X12)	7.5g (70VG/30PG) 3% Menthol Flavoring 1.2% Nicotine
22	18g Coconut GAC (12X40)	9g (70VG/30PG) 3% Menthol Flavoring 1.2% Nicotine

[0051] The pellet substrates **31** of Example 20 were formed by mixing about 15 grams by weight of Cabot Corporation NORIT[®] GCN 816G 8X16 mesh coconut shell based granular activated carbon (GAC) pellets together with about 7.5 grams by weight of an e-liquid solution containing an aerosol former consisting of about 70% vegetable glycerin (VG) and

about 30% propylene glycol (PG) admixed with menthol flavoring at about 3% and nicotine at about 1.2%.

[0052] The pellet substrates **31** of Example 21 were formed by mixing about 15 grams by weight of Cabot Corporation NORIT[®] GCN 612G 6X12 mesh coconut shell based granular activated carbon (GAC) pellets together with about 7.5 grams by weight of an e-liquid solution containing an aerosol former consisting of about 70% vegetable glycerin (VG) and about 30% propylene glycol (PG) admixed with menthol flavoring at about 3% and nicotine at about 1.2%.

[0053] The pellet substrates **31** of Example 22 were formed by mixing about 18 grams by weight of Cabot Corporation NORIT[®] GCN 1240G 12X40 mesh coconut shell based granular activated carbon (GAC) pellets together with about 9 grams by weight of an e-liquid solution containing an aerosol former consisting of about 70% vegetable glycerin (VG) and about 30% propylene glycol (PG) admixed with menthol flavoring at about 3% and nicotine at about 1.2%. The e-liquid solution was allowed to soak into the pellets for at least about 12 hours until fully adsorbed. The pellet substrates **31** were loaded into a vapor delivery device **10**, namely an Iolite[®] butane heat vaporizer. The vaporizer was operated according to the manufacturer's specifications and very good aerosol delivery with no appreciable off taste was achieved.

TABLE 8

Example No.	Porous Inert Substrate	Aerosol Former +
23	16g Coconut GAC (6X12) Mixed With / Added To: 16g Coconut GAC (6X12)	4g Menthol Crystals (70VG/30PG) Menthol Flavoring Nicotine

[0054] The substrates **30** of Example 23 were formed by mixing about 16 grams by weight of Cabot Corporation NORIT[®] GCN 612G 6X12 mesh coconut shell based granular activated carbon (GAC) pellets together with about 4 grams by weight of menthol crystals. Menthol flavoring was infused into the pellet substrates **31** by mixing the menthol crystals together

with the pellets and placing the mixture into a closed container in which the temperature was raised to between about 150°F and about 200°F over a period of time between about 2 hours and about 4 hours. Menthol from the menthol crystals completely vaporized and was adsorbed by the coconut GAC pellets. Pellet substrates **31** according to this example may be added to or mixed with pellet substrates **31** comprising an aerosol former (e.g., vegetable glycerin/propylene glycol) admixed with flavoring and/or nicotine to provide a menthol flavor boost. Likewise, other volatile aromas and/or flavoring, such as coffee, tea, cocoa, oak, hickory and the like, may be infused into granular activated carbon (GAC) based pellet substrates.

TABLE 9

Example No.	Porous Inert Substrate	Aerosol Former +
24	1360g Coconut GAC (6X12)	680g (70VG/30PG) Menthol Flavoring
25	1360g Coconut GAC (6X12)	680g (70VG/30PG) Menthol Flavoring 1.2% Nicotine
26	1360g Coconut GAC (6X12)	680g (70VG/30PG) Menthol Flavoring 1.8% Nicotine

[0055] The pellet substrates **31** of Example 24 were formed by mixing about 1360 grams by weight of Carbon Activated Corporation coconut granular activated carbon (GAC) 6X12 mesh pellets together with about 680 grams by weight of an e-liquid solution containing an aerosol former consisting of about 70% vegetable glycerin (VG) and about 30% propylene glycol (PG) admixed with menthol flavoring.

[0056] The pellet substrates **31** of Example 25 were formed by mixing about 1360 grams by weight of Carbon Activated Corporation coconut granular activated carbon (GAC) 6X12 mesh pellets together with about 680 grams by weight of an e-liquid solution containing an aerosol former consisting of about 70% vegetable glycerin (VG) and about 30% propylene glycol (PG) admixed with menthol flavoring and nicotine at about 1.2%.

[0057] The pellet substrates **31** of Example 26 were formed by mixing about 1360 grams by weight of Carbon Activated Corporation coconut granular activated carbon (GAC) 6X12 mesh pellets together with about 680 grams by weight of an e-liquid solution containing an aerosol former consisting of about 70% vegetable glycerin (VG) and about 30% propylene glycol (PG) admixed with menthol flavoring and nicotine at about 1.8%.

[0058] In each of the foregoing Examples 24-26 the pellets adsorbed all of the e-liquid solution to form dry pellet substrates **31**.

TABLE 10

Example No.	Porous Inert Substrate	Aerosol Former +
27	1360g Coconut GAC (6X12)	680g (70VG/30PG) Tobacco Flavoring
28	1360g Coconut GAC (6X12)	680g (70VG/30PG) Tobacco Flavoring 1.2% Nicotine
29	1360g Coconut GAC (6X12)	680g (70VG/30PG) Tobacco Flavoring 1.8% Nicotine

[0059] The pellet substrates **31** of Example 27 were formed by mixing about 1360 grams by weight of Carbon Activated Corporation coconut granular activated carbon (GAC) 6X12 mesh pellets together with about 680 grams by weight of an e-liquid solution containing an aerosol former consisting of about 70% vegetable glycerin (VG) and about 30% propylene glycol (PG) admixed with tobacco flavoring.

[0060] The pellet substrates **31** of Example 28 were formed by mixing about 1360 grams by weight of Carbon Activated Corporation coconut granular activated carbon (GAC) 6X12 mesh pellets together with about 680 grams by weight of an e-liquid solution containing an aerosol former consisting of about 70% vegetable glycerin (VG) and about 30% propylene glycol (PG) admixed with tobacco flavoring and nicotine at about 1.2%.

[0061] The pellet substrates **31** of Example 29 were formed by mixing about 1360 grams by weight of Carbon Activated Corporation coconut granular activated carbon (GAC) 6X12 mesh pellets together with about 680 grams by weight of an e-liquid solution containing an

aerosol former consisting of about 70% vegetable glycerin (VG) and about 30% propylene glycol (PG) admixed with tobacco flavoring and nicotine at about 1.8%.

[0062] In each of the foregoing Examples 27-29 the pellets adsorbed all of the e-liquid solution to form dry pellet substrates **31**.

TABLE 11

Example No.	Porous Inert Substrate	Aerosol Former +
30	32g Coconut GAC (6X12)	16g (70VG/30PG) 5g Tobacco Powder
31	32g Coconut GAC (6X12)	16g (70VG/30PG) 8g Tobacco Blend Powder
32	32g Coconut GAC (6X12)	16g (70VG/30PG) 11.5g Distilled Water 5g Coffee Powder

[0063] The pellet substrates **31** of Example 30 were formed by mixing about 32 grams by weight of Carbon Activated Corporation coconut granular activated carbon (GAC) 6X12 mesh pellets together with about 16 grams by weight of an e-liquid solution containing an aerosol former consisting of about 70% vegetable glycerin (VG) and about 30% propylene glycol (PG) admixed with about 5 grams by weight of tobacco powder. The tobacco powder was finely-ground to less than 20 microns, and more preferably, less than 10 microns. The pellets adsorbed all of the e-liquid solution to form dry pellet substrates **31**.

[0064] The pellet substrates **31** of Example 31 were formed by mixing about 32 grams by weight of Carbon Activated Corporation coconut granular activated carbon (GAC) 6X12 mesh pellets together with about 16 grams by weight of an e-liquid solution containing an aerosol former consisting of about 70% vegetable glycerin (VG) and about 30% propylene glycol (PG) admixed with about 8 grams by weight of tobacco blend powder. The tobacco powder was finely-ground to less than 20 microns, and more preferably, less than 10 microns. The pellets adsorbed all of the e-liquid solution to form dry pellet substrates **31**.

[0065] The pellet substrates **31** of Example 32 were formed by mixing about 32 grams by weight of Carbon Activated Corporation coconut granular activated carbon (GAC) 6X12 mesh pellets together with about 16 grams by weight of an e-liquid solution containing an

aerosol former consisting of about 70% vegetable glycerin (VG) and about 30% propylene glycol (PG) admixed with about 11.5 grams by weight of distilled water and about 5 grams by weight of coffee powder. The liquid solution was adsorbed into the pellets and the pellets were dried at a temperature of about 150°F to remove any residual moisture.

[0066] It should be noted that any dry plant (herbal) material powder, such as coffee powder, tea powder cocoa powder and marijuana powder may be substituted for the tobacco powder in the foregoing examples.

TABLE 12

Example No.	Porous Inert Substrate	Aerosol Former +
33	50g 1/16" AA (7X12)	25g (70VG/30PG) Tobacco Flavoring 1.8% Nicotine
34	55.2g 1/16" AA (7X12)	27.6g (70VG/30PG) Menthol Flavoring 1.8% Nicotine

[0067] The pellet substrates **31** of Example 33 were formed by mixing about 50 grams by weight of UOP Honeywell D-201 1/16" diameter spherical activated alumina (AA) 7X12 mesh pellets together with about 25 grams by weight of an e-liquid solution containing an aerosol former consisting of about 70% vegetable glycerin (VG) and about 30% propylene glycol (PG) admixed with tobacco flavoring and nicotine at about 1.8%.

[0068] The pellet substrates **31** of Example 34 were formed by mixing about 55.2 grams by weight of UOP Honeywell D-201 1/16" diameter spherical activated alumina (AA) 7X12 mesh pellets together with about 27.6 grams by weight of an e-liquid solution containing an aerosol former consisting of about 70% vegetable glycerin (VG) and about 30% propylene glycol (PG) admixed with menthol flavoring and nicotine at about 1.8%.

[0069] In each of the foregoing Examples 33-34 the pellets adsorbed all of the e-liquid solution to form dry pellet substrates **31**. In addition, these pellet substrates **31** delivered an excellent volume of aerosol and a satisfying flavor when used in a dry plant (herbal) material type vaporizer.

TABLE 13

Example No.	Porous Inert Substrate	Aerosol Former +
35	50g Coconut GAC (6X12)	20g Mixture: 0.2g NaCMC and 100g Distilled Water
36	50g 1/16" AA (7X12)	30g Mixture: 0.2g NaCMC and 100g Distilled Water

[0070] The pellet substrates **31** of Example 35 were formed by coating about 50 grams by weight of Carbon Activated Corporation coconut granular activated carbon (GAC) 6X12 mesh pellets with about 20 grams by weight of a mixture comprising about 0.2 grams by weight of Ashland Inc. Aqualon® sodium carboxymethylcellulose (NaCMC) type 7-LF (CMC-7LF) together with about 100 grams by weight of distilled water. The liquid solution was allowed to absorb into and adsorb onto the porous structure of the activated carbon. The remaining excess moisture was removed by drying the coated pellets in a heated environment at a temperature of about 150°F for about 24 hours.

[0071] The pellet substrates **31** of Example 36 were formed by coating about 50 grams by weight of UOP Honeywell D-201 1/16" diameter spherical activated alumina (AA) 7X12 mesh pellets with about 30 grams by weight of a mixture comprising about 0.2 grams by weight of Ashland Inc. Aqualon® sodium carboxymethylcellulose (NaCMC) type 7-LF (CMC-7LF) together with about 100 grams by weight of distilled water. The liquid solution was allowed to absorb into and adsorb onto the porous structure of the activated alumina. The remaining excess moisture was removed by drying the coated pellets in a heated environment at a temperature of about 150°F for about 24 hours.

TABLE 14

Example No.	Porous Inert Substrate	Aerosol Former +
37	20g Coconut GAC (6X12) Treated With NaCMC/H ₂ O	10g (70VG/30PG) Menthol Flavoring 1.8% Nicotine
38	20g 1/16" AA (7X12) Treated With NaCMC/H ₂ O	10g (70VG/30PG) Menthol Flavoring

		1.8% Nicotine
--	--	---------------

[0072] The pellet substrates **31** of Example 37 were formed by mixing about 20 grams by weight of Carbon Activated Corporation coconut granular activated carbon (GAC) 6X12 mesh pellets treated with the mixture of Ashland Inc. Aqualon® CMC-7LF (NaCMC) and distilled water described with reference to Example 35 and Example 36 with about 10 grams by weight of an e-liquid solution containing an aerosol former consisting of about 70% vegetable glycerin (VG) and about 30% propylene glycol (PG) admixed with menthol flavoring and nicotine at about 1.8%.

[0073] The pellet substrates **31** of Example 38 were formed by mixing about 20 grams by weight of UOP Honeywell D-201 1/16" diameter spherical activated alumina (AA) 7X12 mesh pellets treated with the mixture of Ashland Inc. Aqualon® CMC-7LF (NaCMC) and distilled water described with reference to Example 35 and Example 36 with about 10 grams by weight of an e-liquid solution containing an aerosol former consisting of about 70% vegetable glycerin (VG) and about 30% propylene glycol (PG) admixed with menthol flavoring and nicotine at about 1.8%.

TABLE 15

Example No.	Porous Inert Substrate	Aerosol Former +
39	16g Coconut GAC (6X12) Treated With NaCMC/H ₂ O	8g (70VG/30PG) 4g Tobacco Blend Powder
40	31g 1/16" AA (7X12) Treated With NaCMC/H ₂ O	15.5g (70VG/30PG) 7.8g Tobacco Blend Powder

[0074] The pellet substrates **31** of Example 39 were formed by mixing about 16 grams by weight of Carbon Activated Corporation coconut granular activated carbon (GAC) 6X12 mesh pellets treated with the mixture of Ashland Inc. Aqualon® CMC-7LF (NaCMC) and distilled water described with reference to Example 35 and Example 36 with about 8 grams by weight of an e-liquid solution containing an aerosol former consisting of about 70% vegetable glycerin (VG) and about 30% propylene glycol (PG) admixed with about 4 grams by weight of tobacco blend powder.

[0075] The pellet substrates **31** of Example 40 were formed by mixing about 31 grams by weight of UOP Honeywell D-201 1/16" diameter spherical activated alumina (AA) 7X12 mesh pellets treated with the mixture of Ashland Inc. Aqualon® CMC-7LF (NaCMC) and distilled water described with reference to Example 35 and Example 36 with about 15.5 grams by weight of an e-liquid solution containing an aerosol former consisting of about 70% vegetable glycerin (VG) and about 30% propylene glycol (PG) admixed with about 7.8 grams by weight of tobacco blend powder.

TABLE 16

Example No.	Porous Inert Substrate	Aerosol Former +
41	20g Coconut GAC (6X12)	10g Mixture: 20g (70VG/30PG) 5.5g Tobacco Extract 7.8g Flue Cured Extract
42	20g 1/16" AA (7X12)	10g Mixture: 20g (70VG/30PG) 5.5g Tobacco Extract 7.8g Flue Cured Extract

[0076] The pellet substrates **31** of Example 41 were formed by mixing about 20 grams by weight of Carbon Activated Corporation coconut granular activated carbon (GAC) 6X12 mesh pellets with about 10 grams by weight of a mixture of a liquid solution formed from about 20 grams by weight of an e-liquid solution containing an aerosol former consisting of about 70% vegetable glycerin (VG) and about 30% propylene glycol (PG) admixed with about 5.5 grams by weight of tobacco extract and 7.8 grams by weight of a Flue Cured extract.

[0077] The pellet substrates **31** of Example 42 were formed by mixing about 20 grams by weight of UOP Honeywell D-201 1/16" diameter spherical activated alumina (AA) 7X12 mesh pellets with about 10 grams by weight of a mixture of a liquid solution formed from about 20 grams by weight of an e-liquid solution containing an aerosol former consisting of about 70% vegetable glycerin (VG) and about 30% propylene glycol (PG) admixed with about 5.5 grams by weight of tobacco extract and 7.8 grams by weight of a Flue Cured extract.

[0078] It should be noted that extracts of other dry plant (herbal) material, such as coffee, tea and marijuana may be substituted for the tobacco extracts in the foregoing examples.

[0079] Substances, components, elements, materials and mixtures suited for use with the aforementioned pellet substrates according to the present invention include, but are not limited to, the following:

- a) calcium carbonate 5970 available from Specialty Minerals, Inc.;
- b) aerosol formers in solid, semisolid, or liquid form, including polyhydric alcohols and mixtures of polyhydric alcohols, such as glycerin, vegetable glycerin (VG), glycerol, polyethylene glycol (PEG400), propylene glycol, 1,3-butylene glycol, triethylene glycol, glycerol esters, such as triacetin, propylene carbonate, and mixtures thereof, as well as aliphatic esters of mono-, di-, or poly-carboxylic acids, such as methyl stearate, dimethyl dodecandioate, dimethyl tetradecandioate, and others;
- c) organic plant material, for example, tobacco, marijuana, coffee, tea, etc., in a whole, cut, chopped, ground or powder form, and plant extracts, such as a tobacco extract and marijuana extract; and
- d) filler material, for example calcium carbonate, alumina (synthetically produced aluminum oxide), activated carbon powder, graphite powder, combinations thereof, and other similar materials that will not ignite or burn at the vaporization temperatures of the aerosol agent and aerosol forming agent.

[0080] The 6X12, 8X16, 12X30 and 12X40 mesh coconut shell based granulated activated carbon (GAC) pellets as well as the 7X12 mesh 1/16" diameter spherical activated alumina (AA) pellets disclosed herein are well suited for use with certain vapor delivery devices, such as the Iolite[®] butane heat vaporizer. However, pellet substrates **31** having different mesh sizes may be better suited for use with other vapor delivery devices **10**, and in particular, vapor delivery devices powered by an electronic (e.g., battery) power source. As such, the mesh sizes of the pellet substrates **31** disclosed herein are merely exemplary and provided for purposes of explanation and illustration only.

[0081] The foregoing is a description of various exemplary embodiments of the present invention given for purposes of explanation and illustration only. Although various embodiments of vapor delivery devices **10** and pellet substrates **31** configured for use with vapor delivery devices to vaporize and deliver an aerosol to a user, such as a patient or a smoker, have been described herein with reference to the accompany drawing figures, other

embodiments of the invention may exist or become later known that perform similar functions and/or achieve similar results. All such equivalents are considered to be within the spirit and scope of the present invention, and thus, are intended to fall within a broadest reasonable interpretation of the appended claims consistent with this written description and drawings.

That which is claimed is:

1. An aerosol delivery agent for use in a vapor delivery device (10) to vaporize and deliver an aerosol to a user, comprising:
 - a porous inert substrate (42); and
 - a liquid solution comprising an aerosol former;wherein the porous inert substrate (42) adsorbs the liquid solution to form a dry pellet substrate (31) from which the aerosol is vaporized and delivered to the user.
2. The aerosol delivery agent according to claim 1, wherein the porous inert substrate (42) is activated carbon.
3. The aerosol delivery agent according to claim 2, wherein the activated carbon is derived from coconut.
4. The aerosol delivery agent according to claim 2, wherein the activated carbon is granular activated carbon.
5. The aerosol delivery agent according to claim 4, wherein the granular activated carbon has a mesh size between about 30 and about 6.
6. The aerosol delivery agent according to claim 1, wherein the porous inert substrate (42) is activated alumina.
7. The aerosol delivery agent according to claim 1, wherein the aerosol former is selected from the group consisting of glycerin, vegetable glycerin, propylene glycol and combinations thereof.
8. The aerosol delivery agent according to claim 1, wherein the porous inert substrate (42) is coated with a mixture comprising a food grade gum.
9. The aerosol delivery agent according to claim 8, wherein the food grade gum is sodium carboxymethylcellulose (NaCMC).

10. The aerosol delivery agent according to claim 8, wherein the concentration of the food grade gum in the mixture is between about 0.01% and about 5.0%.
11. The aerosol delivery agent according to claim 1, wherein the aerosol former of the liquid solution is admixed with at least one of a therapeutic drug, a menthol flavoring, a tobacco flavoring, a tobacco powder (47), a tobacco extract (48), a dry plant material and nicotine (46).
12. The aerosol delivery agent according to claim 1, wherein the dry pellet substrate (31) is coated with a mixture comprising sodium carboxymethylcellulose (NaCMC) and distilled water, and wherein the concentration of the sodium carboxymethylcellulose in the mixture is less than about 5.0%.
13. A method of forming a dry pellet substrate (31) for use with a vapor delivery device (10) to vaporize and deliver an aerosol, the method comprising:
- providing a porous inert substrate (42) having a plurality of exposed surfaces;
 - providing a liquid solution of an aerosol former and at least one of a therapeutic drug, a menthol flavoring, a tobacco flavoring, a tobacco powder (47), a tobacco extract (48), a dry plant material and nicotine (46);
 - mixing the porous inert substrate (42) and the liquid solution together;
 - allowing the liquid solution to adsorb onto the plurality of exposed surfaces of the porous inert substrate (42); and
 - allowing any excess of the liquid solution on the porous inert substrate (42) to dry.
14. The method according to claim 13, further comprising prior to mixing the porous inert substrate (42) and the liquid solution together;
- coating the porous inert substrate (42) with a mixture comprising a food grade gum wherein the concentration of the food grade gum in the mixture is less than about 5.0%; and
 - drying any excess of the mixture from the plurality of exposed surfaces of the porous inert substrate (42).
15. The method according to claim 13, wherein the porous inert substrate (42) is formed from at least one of activated alumina and granulated activated carbon derived from coconut.

1/2

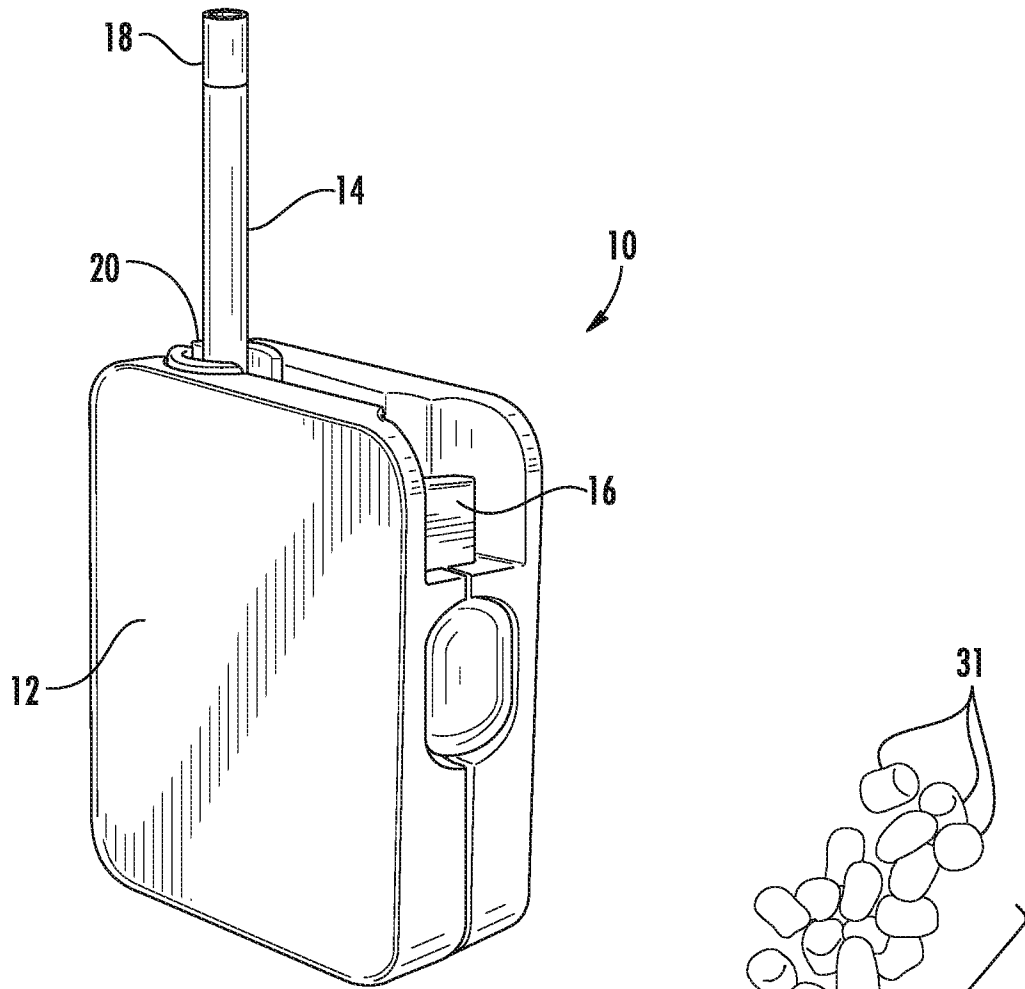

FIG. 1

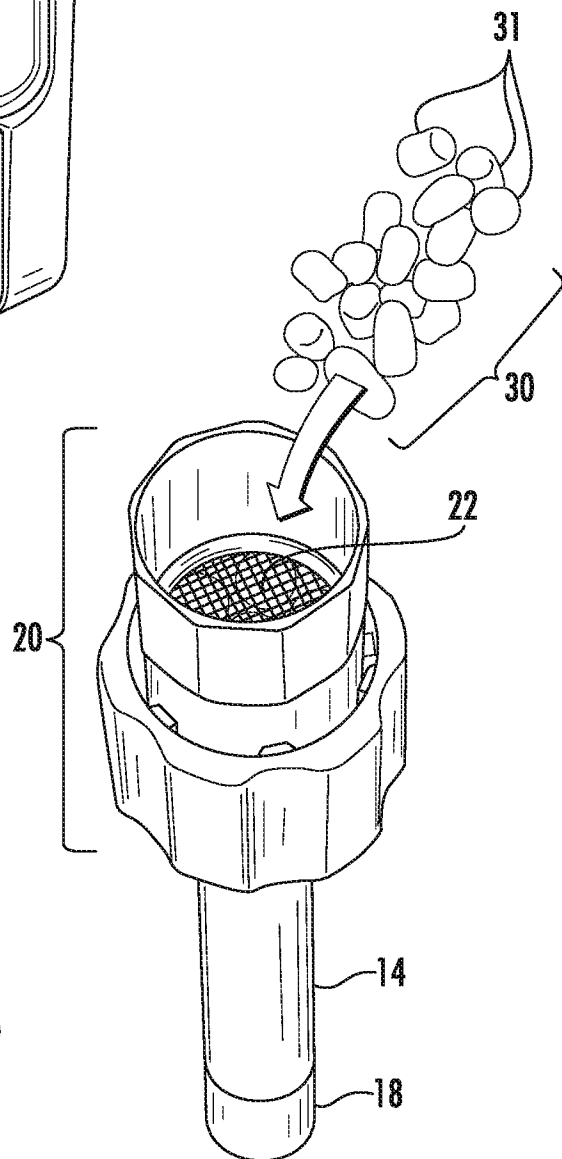

FIG. 2

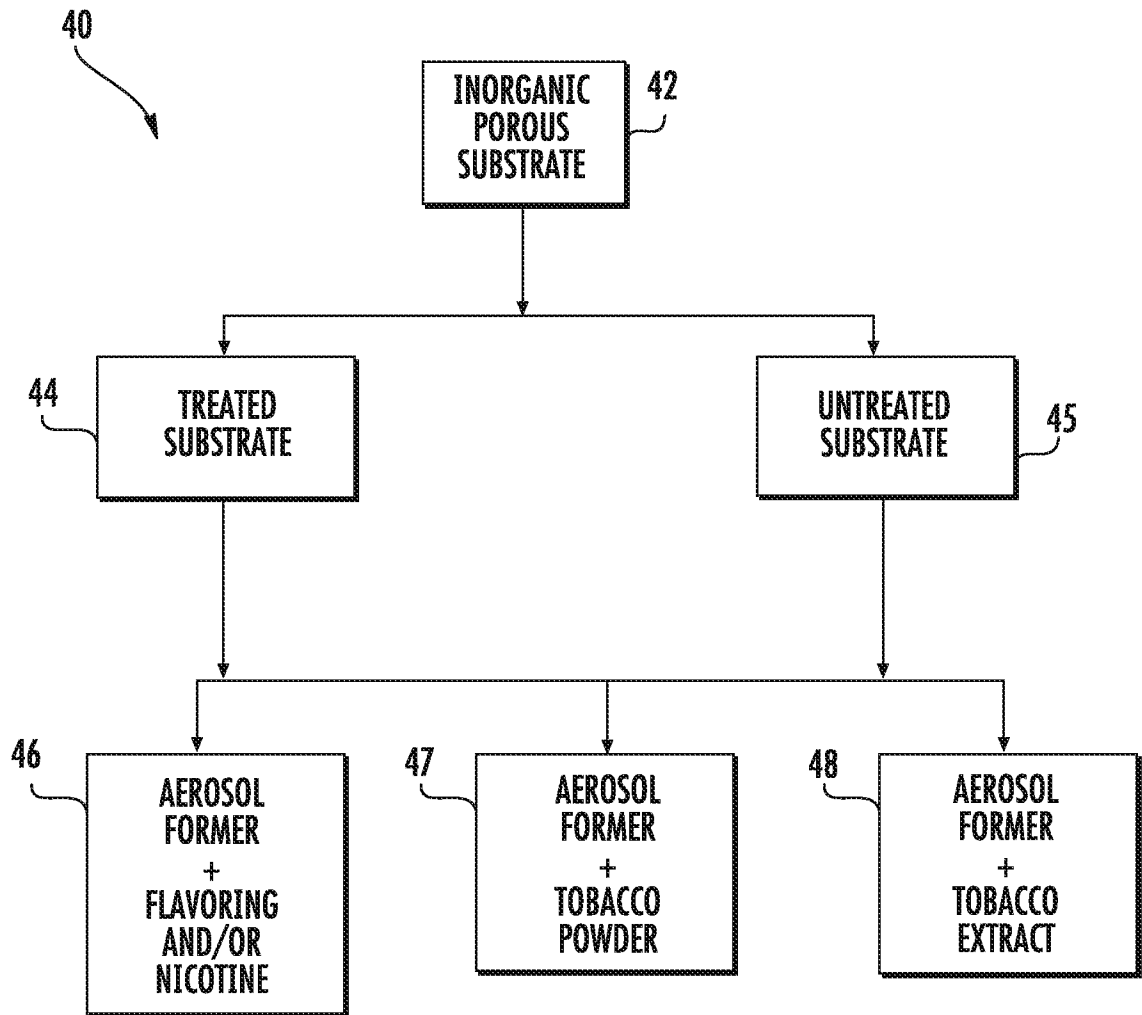

FIG. 3

INTERNATIONAL SEARCH REPORT

International application No
PCT/US2018/042194

A. CLASSIFICATION OF SUBJECT MATTER
INV. A24B15/16 A24F47/00 A61M11/04 A61M15/00 A61M15/06
ADD.

According to International Patent Classification (IPC) or to both national classification and IPC

B. FIELDS SEARCHED

Minimum documentation searched (classification system followed by classification symbols)
A24B A24F A61M A24D

Documentation searched other than minimum documentation to the extent that such documents are included in the fields searched

Electronic data base consulted during the international search (name of data base and, where practicable, search terms used)

EPO-Internal

C. DOCUMENTS CONSIDERED TO BE RELEVANT

Category*	Citation of document, with indication, where appropriate, of the relevant passages	Relevant to claim No.
X A	US 2015/101606 A1 (WHITE JACKIE L [US]) 16 April 2015 (2015-04-16) paragraph [0001] paragraph [0008] paragraph [0032] paragraph [0043] - paragraph [0044] paragraph [0047] - paragraph [0048] paragraph [0056] - paragraph [0057] figure Fig.14	1-7,11, 13,15 8-10,12, 14
X	US 2013/255702 A1 (GRIFFITH JR DAVID WILLIAM [US] ET AL) 3 October 2013 (2013-10-03) paragraph [0009] - paragraph [0016] claims 1, 6, 7, 9, 11-13, 15-23, 26, 32, 36, 40	1-15

Further documents are listed in the continuation of Box C.

See patent family annex.

* Special categories of cited documents :

"A" document defining the general state of the art which is not considered to be of particular relevance

"E" earlier application or patent but published on or after the international filing date

"L" document which may throw doubts on priority claim(s) or which is cited to establish the publication date of another citation or other special reason (as specified)

"O" document referring to an oral disclosure, use, exhibition or other means

"P" document published prior to the international filing date but later than the priority date claimed

"T" later document published after the international filing date or priority date and not in conflict with the application but cited to understand the principle or theory underlying the invention

"X" document of particular relevance; the claimed invention cannot be considered novel or cannot be considered to involve an inventive step when the document is taken alone

"Y" document of particular relevance; the claimed invention cannot be considered to involve an inventive step when the document is combined with one or more other such documents, such combination being obvious to a person skilled in the art

"&" document member of the same patent family

Date of the actual completion of the international search 21 September 2018	Date of mailing of the international search report 16/10/2018
--	--

Name and mailing address of the ISA/ European Patent Office, P.B. 5818 Patentlaan 2 NL - 2280 HV Rijswijk Tel. (+31-70) 340-2040, Fax: (+31-70) 340-3016	Authorized officer Dimoula, Kerasina
--	---

INTERNATIONAL SEARCH REPORT

International application No
PCT/US2018/042194

C(Continuation). DOCUMENTS CONSIDERED TO BE RELEVANT		
Category*	Citation of document, with indication, where appropriate, of the relevant passages	Relevant to claim No.
X A	US 4 989 619 A (CLEARMAN JACK F [US] ET AL) 5 February 1991 (1991-02-05) column 1, line 9 - line 13 column 15, line 28 - line 68 column 16, line 25 - line 38 column 16, line 52 - column 17, line 14 -----	1-7,11, 13,15 8-10,12, 14
X	US 2008/110470 A1 (ZHUANG SHUZHONG [US] ET AL) 15 May 2008 (2008-05-15) paragraph [0002] - paragraph [0006] paragraph [0017] - paragraph [0018] paragraph [0020] - paragraph [0021] paragraph [0025] - paragraph [0027] paragraph [0036] paragraph [0038]; table 1 paragraph [0039] paragraph [0043] paragraph [0047] - paragraph [0048] paragraph [0060] -----	1-15
X A	US 4 827 950 A (BANERJEE CHANDRA K [US] ET AL) 9 May 1989 (1989-05-09) column 1, line 50 - column 2, line 4 column 2, line 27 - line 33 column 2, line 50 - line 68 column 3, line 14 - line 38 column 5, line 21 - line 42 -----	1-7,11, 13,15 8-10,12, 14

INTERNATIONAL SEARCH REPORT

Information on patent family members

International application No

PCT/US2018/042194

Patent document cited in search report	Publication date	Patent family member(s)	Publication date
US 2015101606	A1	16-04-2015	NONE
US 2013255702	A1	03-10-2013	CN 104349687 A 11-02-2015 EP 2833744 A1 11-02-2015 ES 2600171 T3 07-02-2017 JP 6218803 B2 25-10-2017 JP 2015512262 A 27-04-2015 US 2013255702 A1 03-10-2013 WO 2013148810 A1 03-10-2013
US 4989619	A	05-02-1991	AU 604799 B2 03-01-1991 BG 47023 A3 16-04-1990 BR 8706670 A 19-07-1988 CA 1295203 C 04-02-1992 CN 87105964 A 22-06-1988 CZ 8708933 A3 14-04-1993 DD 264612 A5 08-02-1989 DE 3777105 D1 09-04-1992 DK 644987 A 10-06-1988 EG 18219 A 30-09-1992 EP 0271036 A2 15-06-1988 ES 2031112 T3 01-12-1992 FI 875409 A 10-06-1988 GR 3004491 T3 31-03-1993 HU 202389 B 28-03-1991 IE 60777 B1 10-08-1994 IL 84483 A 12-05-1991 JP 2919835 B2 19-07-1999 JP S63164875 A 08-07-1988 MA 21128 A1 01-07-1988 MX 163155 B 11-09-1991 NO 875104 A 10-06-1988 PH 23830 A 23-11-1989 PL 269332 A1 29-09-1988 PT 86300 A 01-01-1988 SK 893387 A3 12-04-1995 SU 1724000 A3 30-03-1992 TR 23070 A 21-02-1989 US 4989619 A 05-02-1991 YU 221287 A 30-04-1989 ZA 8708843 B 26-05-1988
US 2008110470	A1	15-05-2008	US 2008110470 A1 15-05-2008 US 2013220351 A1 29-08-2013 US 2017150750 A1 01-06-2017
US 4827950	A	09-05-1989	AU 595743 B2 05-04-1990 BR 8703737 A 29-03-1988 CA 1294122 C 14-01-1992 CN 87105240 A 10-02-1988 DD 298203 A5 13-02-1992 DK 369087 A 29-01-1988 EP 0254848 A2 03-02-1988 FI 872862 A 29-01-1988 HU 202735 B 29-04-1991 IL 82748 A 12-05-1991 JP S6335468 A 16-02-1988 MA 21042 A1 01-04-1988

INTERNATIONAL SEARCH REPORT

Information on patent family members

International application No

PCT/US2018/042194

Patent document cited in search report	Publication date	Patent family member(s)	Publication date
		PH 25345 A	13-05-1991
		PL 266885 A1	29-09-1988
		PT 85415 A	29-07-1988
		SU 1641182 A3	07-04-1991
		TR 23220 A	23-06-1989
		US 4827950 A	09-05-1989
		YU 127687 A	31-12-1988
		YU 150088 A	28-02-1990
		ZA 8704063 B	19-01-1988
<hr/>			