

(Specimens.)

J. FEIRABEND.
WADDING.

No. 468,480.

Patented Feb. 9, 1892.

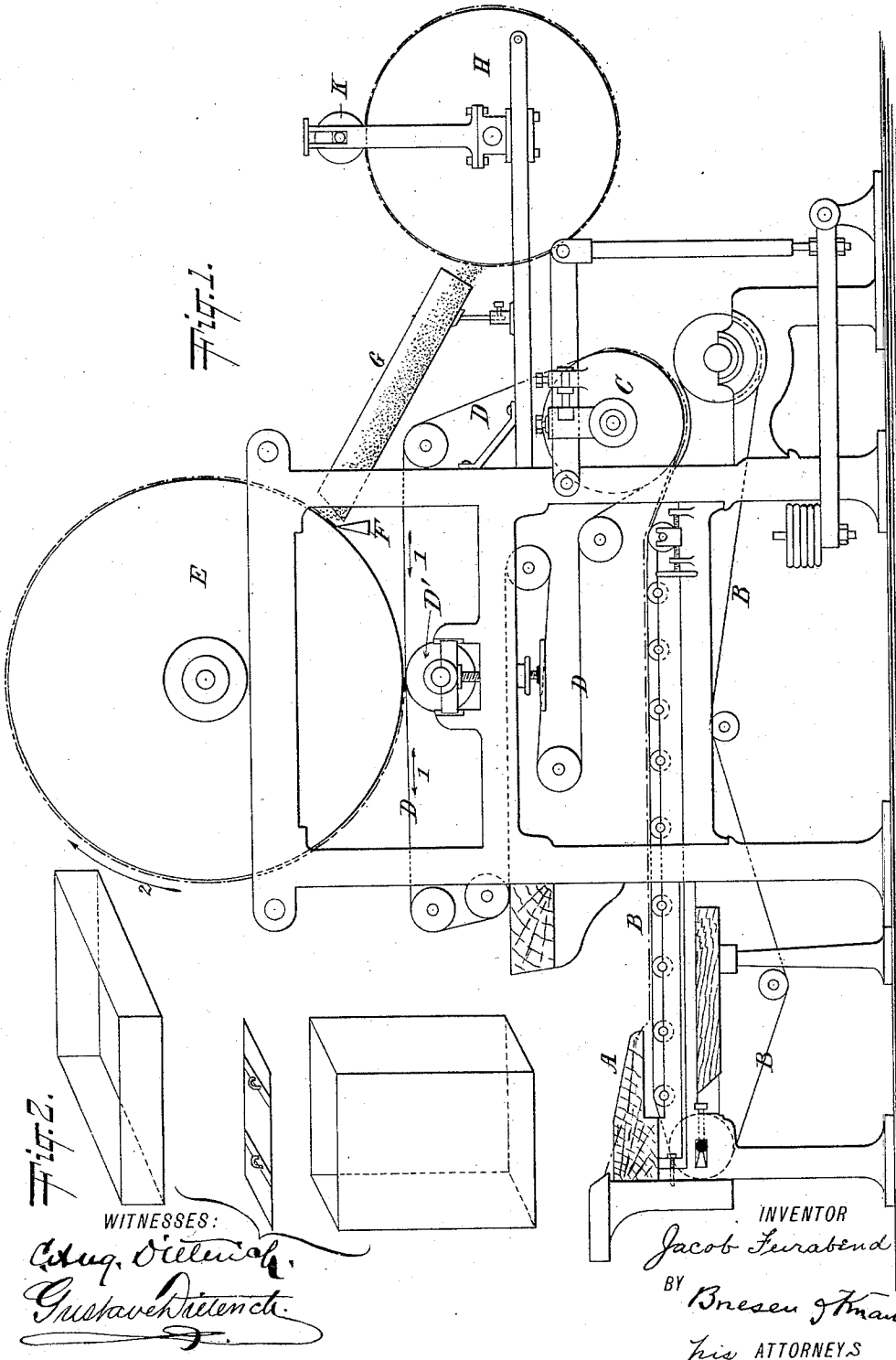

UNITED STATES PATENT OFFICE.

JACOB FEIRABEND, OF NIEDERHAUSEN, GERMANY.

WADDING.

SPECIFICATION forming part of Letters Patent No. 468,480, dated February 9, 1892.

Application filed September 2, 1891. Serial No. 404,512. (Specimens.) Patented in France January 15, 1891, No. 210,800, and in Belgium February 13, 1891, No. 93,804.

To all whom it may concern:

Be it known that I, JACOB FEIRABEND, a subject of the Emperor of Germany, and a resident of Niederhausen, near Frankfort-on-the-Main, Germany, have invented new and useful Improvements in Wadding, of which the following is a specification, and for which I have obtained Letters Patent in France, dated January 15, 1891, No. 210,800, and in Belgium, dated February 13, 1891, No. 93,804.

This invention relates to a new and improved wadding; and it consists in a wadding made up of successive thin layers of filmy or web-like cellulose obtained from wood or other suitable fiber.

My invention is illustrated in the accompanying drawings, in which—

Figure 1 is a side view of a machine by means of which my improved wadding may be formed, and Fig. 2 illustrates forms of receptacles and a lid therefor for forming the sheets of cellulose into wadding of desired form.

A represents the table at the receiving end of the machine, and B an endless sieve-like apron to convey the pulpy fiber to the endless cloth or apron D passing over a roller C in the direction shown by arrows 1 1. E is a rotating drum or drying-roller arranged above said apron D, rotating in the direction indicated by arrow 2, and adapted to take up the fiber therefrom, being assisted by hand at the start of the operation, the end of the sheet of pulp being held by hand to the drum until the action becomes continuous.

F is a scraper arranged alongside the drum E and adapted to remove the fiber from the surface of the drum. To assist in this operation I prefer to form the edge of the scraper F of felt or similar soft substance. G is a trough leading from said scraper F to the roller or cylinder H. K is a pressure-roller arranged to bear upon the surface of said cylinder H.

In operation wood pulp or similar fiber is first boiled under steam-pressure until it is sufficiently disintegrated and softened to be fed into the machine. It is then placed upon the endless sieve-like apron B in a thin and watery condition. When the wet pulp is on

the sieve B, the water runs off through the holes of the sieve, so that when the pulp arrives at the endless belt D on the cylinder C it already has some consistency of paper, but is still sufficiently wet to adhere to the belt D and afterward to the cylinder E, to which it is carried by the belt D, assisted by the pressure-roller D'. On this cylinder E, which rotates, and which is preferably heated internally, the wet paper becomes dry, and is then scraped off by the scraper F. The pulp on the sieve B is a very thin film, so as to obtain a paper which is like spider's web. This spider-web-like paper is scraped off and rumbled into small folds by the scraper F, which is not sharp, but coated with felt, so that the paper is not put off evenly but rumbled, as will be readily understood. This rumbled paper slides over the trough G, and is then taken up by the cylinder H. As soon as the layers of fiber upon the surface of the cylinder H are sufficient in number and the wadding thus formed is sufficiently thick, the wadding is cut and removed from the cylinder and afterward cut into sheets or wads of requisite size.

When sheets of wadding of special form and thickness are desired, the frames or receptacles shown in Fig. 2 may be substituted for the roller or cylinder H and the fiber fed directly from the scraper into the same zig-zag fashion. A weighted lid is placed above the wadding when the receptacle is filled and the pressure of this lid is sufficient to cause the thin sheets of fiber to mat and wad together.

Having thus described my invention, what I claim is—

1. As a new article of manufacture, wadding formed of cobwebby and rumbled layers of cellulose tissue, substantially as described.
2. As a new article of manufacture, wadding formed of coherent layers of cobwebby rumbled cellulose tissue, as specified.

In testimony whereof I have signed my name to this specification in the presence of two subscribing witnesses.

JACOB FEIRABEND.

Witnesses:

JEAN GRUND,
ALVESTO S. HOGUE.