

Sept. 8, 1970

E. E. COLBY ET AL

3,527,377

PROTECTIVE MEMBER FOR SHARP-EDGED DISPENSING OPENINGS

Filed Sept. 27, 1968

Fig. 1

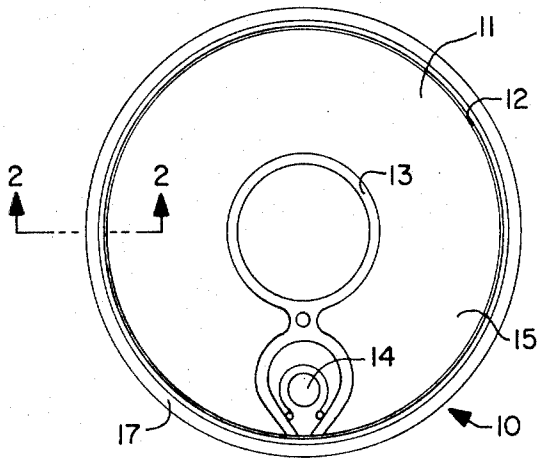

Fig. 2

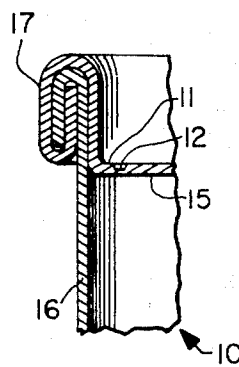

Fig. 3

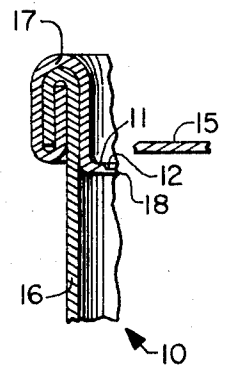

Fig. 4

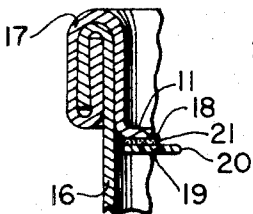

Fig. 5

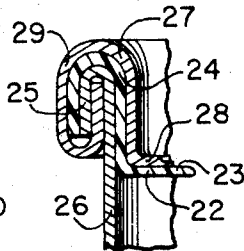

Fig. 6

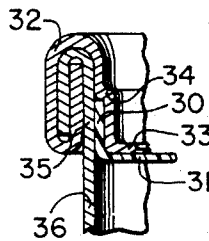

Fig. 7

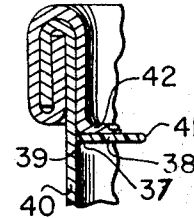

Fig. 8

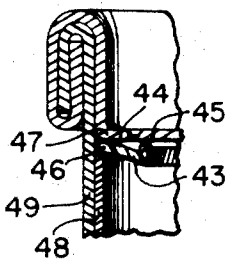

Fig. 9

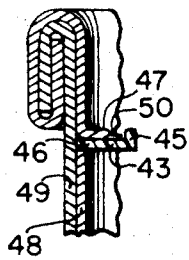

Fig. 10

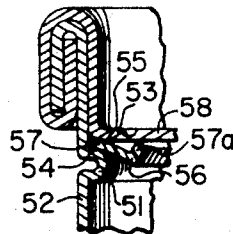

Fig. 11

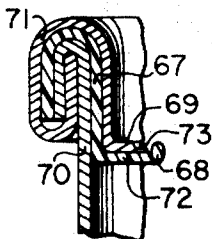
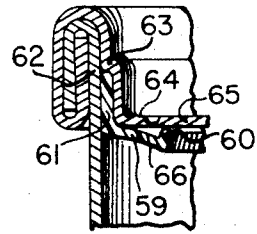

Fig. 12

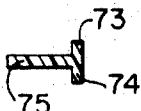

Fig. 13

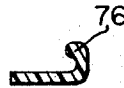

Fig. 14

INVENTORS
Edward E. Colby
David C. O'Neill

By

Asbury Morgan

ATTORNEY

1

2

3,527,377

**PROTECTIVE MEMBER FOR SHARP-EDGE
DISPENSING OPENINGS**

Edward E. Colby, Cincinnati, and David C. O'Neill,
Springfield Township, Hamilton County, Ohio, as-
signors to The Procter & Gamble Company, Cincin- 5
nati, Ohio, a corporation of Ohio

Filed Sept. 27, 1968, Ser. No. 763,223

Int. Cl. B65d 17/00, 17/24

U.S. Cl. 220—54

5 Claims 10

ABSTRACT OF THE DISCLOSURE

A protective member positioned adjacent the inner sur-
face of a container wall and surrounding a dispensing
opening defined by a score line. The protective member
has a blunt edge which extends into the dispensing open-
ing in order to prevent direct contact with the sharp
residual edge of the dispensing opening when product
is being manually withdrawn from the container. 15 20

BACKGROUND OF THE INVENTION

This invention relates to easy-opening containers hav-
ing dispensing openings defined by score lines impressed
in a wall of the container. More particularly, it relates to
a protective member underlying such a score line and
having a portion thereof extending into the dispensing
opening which results when the removable portion of the
container wall defined by the score line is separated from
the container. 25 30

Containers having a dispensing opening formed in a
metallic wall thereof, and defined by one or more score
lines which can be ruptured to provide a dispensing open-
ing, can present a very significant cut hazard to consum-
ers who utilize such containers. This is particularly true
in the case of containers in which a large dispensing
opening is provided in order to permit the consumer to
partially insert his hand into the dispensing opening to
assist in the periodic removal of product therefrom. Since
the metallic walls in which such dispensing openings are
provided are thin, being on the order of about 10 to 15
mils in thickness, the resulting edge can be very sharp
and can cause severe cuts to a consumer's hands if he
is not extremely careful in withdrawing the product from
within the container.

Although numerous products are packaged in con-
tainers having such dispensing openings and in which the
product is not removed by inserting the hand within the
container in the course of the product withdrawal op-
eration, such as, for example, beverages, a number of
other types of products packaged in such containers are
intended to permit periodic dispensing of the product
contained therein. Examples of such products are plastic
shortening and ground coffee. In each case these prod-
ucts are intended to be spooned from the container in
which they are packaged and the large-size containers
in which they are generally packaged results in the neces-
sity for the consumer to partially insert his hand into
the container beyond the edge of the dispensing opening
and thus exposes him to the risk of having his hand cut
by the sharp residual edge which results when the remov- 35 40 45 50 55 60

able portion defining the dispensing opening is separated
from the container wall in which it is impressed.

It has been recognized that a sharp-edged fin fre-
quently results when such a score line defining a dispens-
ing opening is severed. Taylor, in U.S. Pat. 3,244,315,
shows a container end having a removable portion in the
shape of a dispensing opening defined by a closed score
line. Each of the sidewalls of the score line is an in-
clined straight line, but the bottom wall forms an area
of varying thickness with the lower surface of the wall in
which the score line is impressed. The area of minimum
thickness forms the edge of the portion of the panel that
remains after the removable section has been separated.
The effect of this configuration is to insure that the sharp-
edge fin which would otherwise remain is removed to-
gether with the removable portion to thereby reduce the
cut hazard to the consumer. However, effective as this
approach might be, the fact that the container walls in
which such dispensing openings are provided are as thin
as they are, still provides a significant cut hazard which
the present invention overcomes.

SUMMARY OF THE INVENTION

Briefly stated, in connection with one aspect of the
present invention, a protective member is positioned
adjacent the inner surface of an end wall of a container
which includes a removable portion defined by a score
line impressed in the outer surface of the end wall to
provide a dispensing opening therein. The protective
member underlies the score line and has an obtuse edge
which extends inwardly into the dispensing opening. 35 40

BRIEF DESCRIPTION OF THE DRAWING

FIG. 1 is a top view of an end of a cylindrical con-
tainer in which a circular score line is impressed to de-
fine a removable panel and to which is attached a pull
tab to facilitate rupture of the score line and subsequent
removal of the panel to provide a dispensing opening
therein.

FIG. 2 is an enlarged, fragmentary cross-sectional
view taken along the line 2—2 of FIG. 1.

FIG. 3 is an enlarged, fragmentary cross-sectional view
similar to FIG. 2 but showing the relationship of the re-
movable portion to the remainder of the container end
after the score line has been ruptured. 45

FIG. 4 is an enlarged, fragmentary cross-sectional
view similar to that of FIG. 3 but in which a protective
member of the present invention is affixed to the under-
side of the top wall of the container.

FIG. 5 is an enlarged, fragmentary, cross-sectional
view showing another way in which the protective mem-
ber of the present invention can be attached to the con-
tainer. 50

FIG. 6 is an enlarged, fragmentary cross-sectional
view showing still another way in which the protective
member of the present invention can be attached to the
container. 55

FIG. 7 is an enlarged, fragmentary cross-sectional
view showing still another way in which the protective
member of the present invention can be attached to a
container. 60

FIG. 8 is an enlarged, fragmentary cross-sectional
view showing another embodiment of the protective mem-

ber of the present invention prior to rupturing the score line.

FIG. 9 is an enlarged, fragmentary cross-sectional view similar to that of FIG. 8 but in which the score line has been ruptured and shows the protective member in position relative to the residual edge of the score.

FIG. 10 is an enlarged, fragmentary cross-sectional view similar to FIG. 8 but showing another method by which the protective member of the present invention can be attached to the container.

FIG. 11 is an enlarged, fragmentary cross-sectional view showing still another way in which the protective member of the present invention can be attached to a container.

FIG. 12 is an enlarged, fragmentary cross-sectional view showing still another way in which the protective member of the present invention can be attached to a container.

FIG. 13 is a cross-sectional view of another form of protective member.

FIG. 14 is a cross-sectional view of still another form of protective member.

DESCRIPTION OF THE PREFERRED EMBODIMENTS

Referring now to the drawing, and particularly to FIG. 1 thereof, there is shown an end view of a cylindrical container 10 in which end wall 11 includes a circular score line 12 impressed therein and a pull tab 13 attached to the area within the score line by means of a rivet 14. The pull tab 13 serves to initiate the rupture of score line 12 and provides a convenient means by which the removable portion 15 can be separated from the remainder of the top wall. The structure and operation of such a pull tab is described in greater detail in U.S. Pat. 3,322,296, issued May 30, 1967, to N. S. Khoury. The disclosures of the above-cited Khoury patent are herein incorporated by reference.

The configuration and position of score line 12 in relation to end wall 11 and sidewall 16 of container 10 are shown more clearly in FIG. 2. As therein shown, container 10 comprises end wall 11 and sidewall 16 which are interlocked by a double seam bead 17. Although not shown, the container can have a bottom wall positioned in the same relation to sidewall 16 as end wall 11, or it can also have an integral bottom wall such as that which results when a slug of metal is extruded in a manner well known to those skilled in the art to form a tubular container closed at one end. Score line 12 is shown in relationship to end wall 11 and sidewall 16 and is of generally trapezoidal cross section. In the configuration illustrated in FIG. 1, score line 12 is uniformly spaced from bead 17 along its entire periphery. However, score line 12 can take on many other configurations to form any of a variety of shapes of dispensing openings.

The end walls in which such score lines are impressed are generally made from tinplate which has a thickness which can range from about 5 mils (0.005 inch) to about 14 mils, or they can be made from aluminum which can have a thickness which ranges from about 10 mils to about 20 mils. Typically, tinplate end walls have a thickness of about 9 mils and the score lines are impressed therein to such a depth that a residual thickness of about 2 mils results. In the case of aluminum end walls a typical thickness is 10.5 mils with a residual thickness of 2.5 to 5.0 mils at the thinnest portion of the score line. This arrangement has been found to provide container integrity while permitting easy removal of the removable panel.

Removable panel 15 is severed from end wall 11 by pulling upwardly on pull tab 13. FIG. 3 shows score line 12 after the removable portion has been severed. As therein shown, a sharp residual fin 18 frequently results when such score lines are ruptured. These fins are very

sharp and thin and can present a significant cut hazard to a consumer.

Although the ensuing discussion will be confined to a cylindrical, metallic container having a circular end wall, it is to be understood that the present invention is not so limited and it can be used in conjunction with a container of noncircular cross section such as, for example, an oval cross section or a rectangular cross section, and it can also be used in conjunction with other, generally non-metallic containers, such as, for example, plastic containers, fiber containers, or foil-fiber containers, in which at least one wall thereof is of a metallic construction and has a dispensing opening therein defined by at least one score line.

One form of the present invention is shown in FIG. 4 wherein a protective member 19 is positioned on the underside of the end wall 11 and has a portion thereof extending into the dispensing opening and terminating in an obtuse edge 20. Protective member 19 is flat and of generally annular configuration and is adherently secured to the underside of end wall 11 at a position outwardly of the score line by means of an adhesive layer 21. Protective member 19 can be made of any number of materials so long as it provides the obtuse edge to in effect space the residual sharp fin 18 from the hands of a consumer when the latter are inserted into the container to withdraw product therefrom. However, from the standpoints of economy and performance, it is preferred that protective member 19 be formed from flexible, resilient plastic substances such as, for example, polyethylene, polypropylene, polyvinyl chloride, polystyrene, and the like, which are compatible with the product packaged in the container. Furthermore, protective member 19 can be formed, for example, by injection molding to provide a continuous, closed circular ring, or it can be made discontinuous, if desired. If it is discontinuous, however, any gap that might exist between adjacent portions of the ring should be minimized so as to preclude contact by a consumer's hand with the sharp edge when the ring is positioned on the underside of the top wall of the container.

The minimum thickness for the protective member is dependent upon the material from which it is made. Preferably, however, protective member 19 is at least about 10 mils in thickness so as to present sufficient rigidity that it cannot be easily deflected. In addition, it is preferred that the inner, obtuse edge 20 of the protective member extend inwardly into the dispensing opening beyond residual edge 18 a distance of at least $\frac{1}{32}$ ". If it were to be spaced closer, the likelihood of direct contact between the consumer's hand and residual edge would be considerably increased. When adhered to the innermost surfaces of end wall 11 as shown in FIG. 4, adhesive layer 21 should provide a sufficiently strong bond to prevent protective member 21 from becoming dislodged in the course of the use of the container. Suitable adhesives for this purpose are hot melt adhesives, epoxy adhesives, and ionomer-based adhesives and are so applied as to attach protective member 19 to the residual portion of end wall 11 which remains when the removable portion is severed therefrom along the score line.

The protective member of the present invention can also be attached to the container by including an outer portion thereof within the double seam formed at the junction between the top wall and the sidewall as shown in FIG. 5. In that embodiment it is preferred that protective member 22 be of a flange-like configuration comprising a laterally extending protective portion 23 and an upwardly extending connecting portion 24, the junction of which substantially forms a right angle. Protective portion 23 parallels the residual edge of the top wall. In this connection protective member 22 should be preformed to provide the required right angle. Connecting portion 24 of protective member 22 is positioned between the upper portion 25 of sidewall 26 and the outer por-

5

tion 27 of the end wall 28 to be interlocked therebetween when double seam 29 is formed. When this configuration is utilized, connecting portion 24 can be made thinner than the protective portion 23, if desired, in order to reduce the amount of material necessary and thereby reduce cost.

Another way in which the protective member of the present invention can be attached to the container is shown in FIG. 6. This embodiment is a variant of the configuration shown in FIG. 5 except that upwardly-extending connective portion 30 of protective member 31 is not completely positioned within double seam 32. Instead, the container end wall 33 includes a stepped portion 34 and upwardly extending connecting portion 30 is held between stepped portion 34 and upper portion 35 of sidewall 36. Again, in this configuration also it is preferred that protective member 31 be pre-formed into the right-angle shape so that the innermost portion of protective member 31 is positioned adjacent the inner surface of end wall 33.

Another way in which the protective member of the present invention can be secured within the container is to so size the protective member in relation to the inner diameter of the container to produce an interference fit therebetween. This arrangement is shown in FIG. 7 wherein the outermost portion 37 of ring 38 is slightly larger than the inner surface 39 of sidewall 40 so that there is a compressive force applied to protective member 38 which tends to hold it in position. However, the interference fit must not be so excessive as to deflect protective member 38 at inner blunt edge 41 thereof and thereby reduce its effectiveness by causing it to deflect away from the inner surface of end wall 42. In this connection an interference of from about 1 to about 5 mils between outer diameter 37 of protective member 38 and inner diameter 39 of sidewall 40 is preferred to accomplish this purpose.

In addition to a flat-ring-like protective portion as shown in FIGS. 4-7, the protective member of the present invention can include an upstanding step or flange on its innermost edge. This arrangement permits the sharp residual edge of the score to be more fully covered and thereby provides additional protection. One way in which such a structure can be formed and applied to a container is shown in FIG. 8. As shown, the protective member 43 includes a flat, annular portion 44, at the innermost end of which is an upstanding flange 45. Outermost edge 46 of the protective member is positioned between the inner surface of end wall 47 and a peripheral liner 48 which is positioned adjacent the inner surface of sidewall 49. When protective member 43 is so positioned upstanding flange 45 precludes the placement of the upper surface of protective member 43 adjacent the lower surface of end wall 47 and thus the stepped end of the protective member is deflected downwardly slightly as shown in FIG. 8. When the removable portion of end wall 47 is separated therefrom protective member 43 is resiliently urged into contact with the inner surface of end wall 47 as shown in FIG. 9. As therein shown, upstanding flange 45 more completely covers residual edge 50 and thereby further reduces the cut hazard to the consumer.

Liner 49, which supports protective member 43, can be any material compatible with the product packaged within the container. Thus uncoated paperboard, paperboard coated with wax, plastics, or the like, or plastics can be utilized to form a peripheral liner to support protective member 43 at its outermost edge 46. Furthermore, although a flat liner is satisfactory, one that is corrugated provides increased strength and more firmly supports the protective member. Thus the liner can be a corrugated sheet of, for example, paper, plastic, or glassine alone or it can have one or more facing sheets of such material affixed thereto.

Another way in which such a flanged protective member can be held in position is by means of an inwardly extending bead 51 in sidewall 52 of the container, with

6

the bead spaced slightly below end wall 53 as shown in FIG. 10. The spacing between the topmost surface 54 of bead 51 and lower surface 55 of end wall 53 is preferably equal to or slightly less than the thickness of protective member 56 at its outermost end 57. Thus protective member 56 is restrained between the two cooperating surfaces and, as shown in FIG. 10, when end wall 53 is intact protective member 56 is deflected downwardly at its flanged end 57a. When removable portion 58 is separated from end wall 53 the resilience of protective member 56 urges flanged end 57a upwardly so that the relative positioning of the several elements are similar to those shown in FIG. 9.

FIG. 11 shows still another way in which the protective member of the present invention can be secured to the container. In this embodiment protective member 59 has a small upstanding flange 60 at its innermost end and a somewhat larger upstanding flange 61 at its outermost end. The latter flange is adapted to be cooperatively gripped by the container sidewall 62 and an inwardly directed step 63 in the end wall 64. Again, prior to separation of removable panel 65 from end wall 64, protective member 59 is in deflected condition and upon removal of panel 65 protective member 59 returns to its original, non-deflected condition such that the upper surface 66 of the web interconnecting flanges 60 and 61 is adjacent the inner surface of end wall 64, and flange 60 is positioned adjacent the residual edge which remains when removable panel 65 is separated.

Still another way in which the stepped protective member can be secured to the container is shown in FIG. 12. In that configuration the outermost flanged portion 67 is considerably larger than the innermost flange 68 and is adapted to be secured between end wall 69 and sidewall 70 within double seam bead 71. Flanged portion 67 is formed integrally with the web 72 which connects that portion and innermost flange 68 so that when removable section (not shown) is separated the upper surface of interconnecting web 72 is adjacent the lower surface of end wall 69 of the container, thereby positioning the innermost flange 68 in protective relationship with respect to the sharp residual edge 73.

FIGS. 13 and 14 show further alternative cross-sectional configurations for the protective member of the present invention. The configuration shown in FIG. 13 is similar to the flange configuration generally shown in FIGS. 8 and 9 except that it is symmetrical about a transverse axis in that it has flanges 73 and 74 extending from annular ring 75. In this arrangement, since the protective member is symmetrical, there is not an orientation problem when it is to be positioned within the container and therefore it is reversible side-for-side and thereby facilitates assembly of the entire container. The cross section shown in FIG. 14 is another variant to provide still further protection in that the outer curved portion 76 spaces the fingers of the user further from the sharp edge.

It can thus be seen that the protective member of the present invention provides a significant improvement in connection with the use of containers having dispensing openings defined by score lines which are intended to be severable to remove panels from the containers. The invention is particularly useful in those containers wherein the dispensing opening is relatively large to permit the removal of product to be effected by insertion of the user's hand into the dispensing opening.

While particular embodiments of the invention have been illustrated and described, it will be apparent to those skilled in the art that various changes and modifications can be made without departing from the spirit and scope of the invention, and it is intended to cover in the appended claims all such changes and modifications that are within the scope of this invention.

What is claimed is:

1. In a container having an end wall including a removable portion defined by a score line impressed in the

7

outer surface of said end wall to provide a dispensing opening therein upon removal of said removable portion, the improvement comprising a flexible protective member positioned adjacent the inner surface of said end wall and underlying said score line, said protective member including an upstanding flange positioned inwardly of said score line.

2. The container of claim 1 wherein said upstanding flange rests against the inner surface of the removable portion of said end wall prior to removal thereof, said protective member resiliently upwardly urging said flange upon removal of said removable portion whereby to cause said flange to cover the residual edge which remains when said score line is severed.

3. The container of claim 2 wherein said container includes a side wall and said protective member is supported

8

by a peripheral liner positioned adjacent the inner surface of said side wall.

4. The container of claim 3 wherein said peripheral liner is of a corrugated form.

5. The container of claim 4 wherein said protective member is symmetrical and includes an upstanding flange and a depending flange at its innermost edge.

References Cited

UNITED STATES PATENTS

3,409,166	11/1968	La Croce et al.	-----	220—54
3,447,713	6/1969	Stec	-----	220—54

GEORGE T. HALL, Primary Examiner

U.S. Cl. X.R.

220—27, 90.6