

H. J. YOUNT.
 REIN HOLDER.

APPLICATION FILED JULY 2, 1908.

915,528.

Patented Mar. 16, 1909.

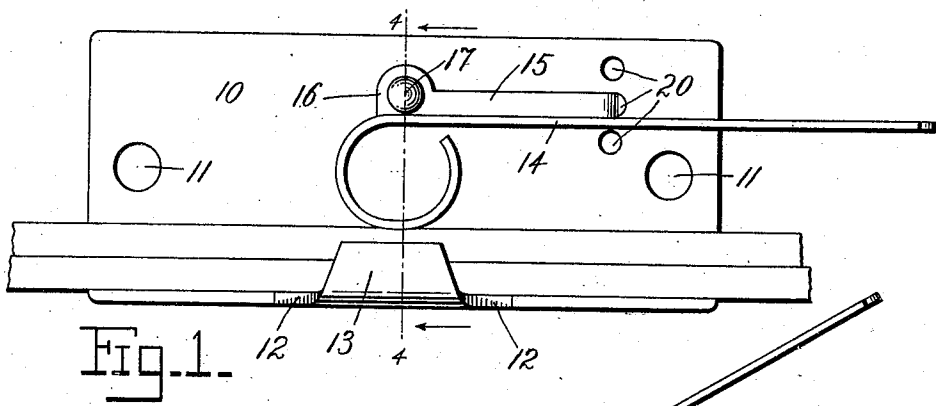

Fig. 1.

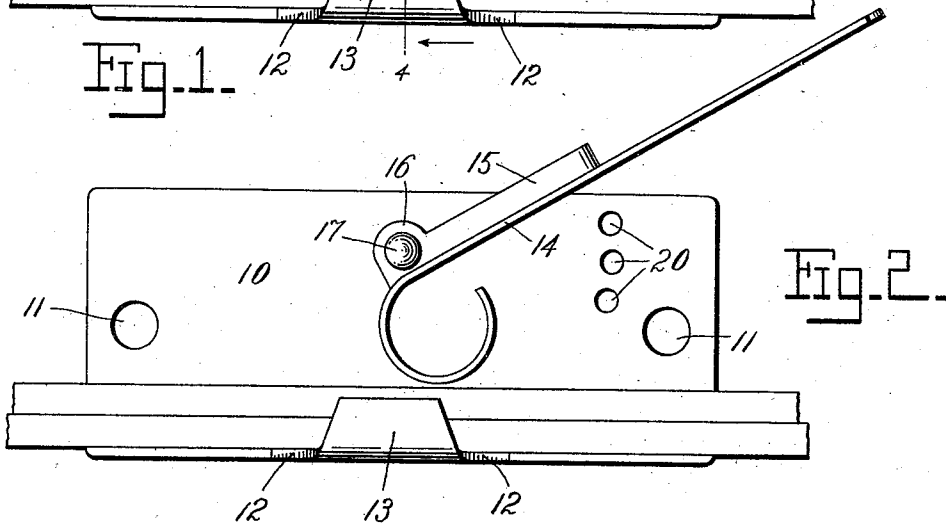

Fig. 2.

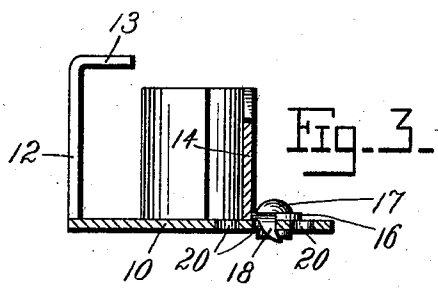

Fig. 3.

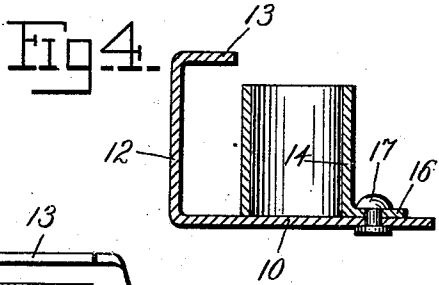

Fig. 4.

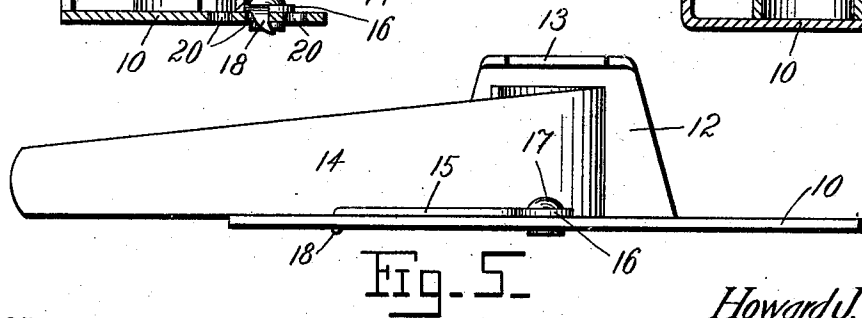

Fig. 5.

Witnesses

F. Sonoyama.
M. J. Miller

Inventor
Howard J. Yount.

By

Charles. Charles

Attorneys

UNITED STATES PATENT OFFICE.

HOWARD J. YOUNT, OF VERNON, COLORADO.

REIN-HOLDER.

No. 915,528.

Specification of Letters Patent.

Patented March 16, 1909.

Application filed July 2, 1908. Serial No. 441,569.

To all whom it may concern:

Be it known that I, HOWARD J. YOUNT, a citizen of the United States, residing at Vernon, in the county of Yuma, State of Colorado, have invented certain new and useful Improvements in Rein-Holders; and I do hereby declare the following to be a full, clear, and exact description of the invention, such as will enable others skilled in the art to which it appertains to make and use the same.

This invention relates to rein holders and it has for its object to provide a construction which will be cheap and simple of manufacture and which may be secured to the back band or any other part of a harness when the latter are not in use.

A further object of the invention is to provide a specific structure embodying an eccentrically mounted clamping member which will have a more or less spring action against the reins and in which the clamping member will not only be held securely in its clamping position, but may be easily and quickly removed from said position.

In the drawings forming a portion of this specification and in which like numerals of reference indicate similar parts in the several views: Figure 1 is a top plan view showing the present device in its clamping position and reins held therein. Fig. 2 is a view similar to Fig. 1 showing the clamping members in inactive position. Fig. 3 is a transverse section through the perforated portion of the plate and the lever or handle of the clamp. Fig. 4 is a transverse section on line 4—4 of Fig. 1, through the upstanding flange and the pivot of the movable clamping members. Fig. 5 is a side elevation of the structure looking from the edge opposite to the upstanding flange.

Referring now to the drawings, the present invention comprises a base plate 10, having perforations 11 at suitable portions to receive rivets or other attaching means for securing it to the back band or other convenient part of a harness. From one longitudinal edge of the plate 10 there extends upwardly and over the plate 10 a flange 12, the upper extremity 13 of which is bent at a sharp angle to lie above and in parallel relation to the plate 10. The upstanding flange 12 forms one element of a clamp, the other element being a movable one and consisting of a plate 14, disposed with one longitudinal edge upon the plate 10, and having at this

said longitudinal edge, the horizontally extending flange 15 which bears directly upon the plate 10. At one end of this flange 15 there is formed an ear 16 which is perforated and receives a pivot 17 which is passed there-through and into the plate 10 and forms a pivotal connection for the movable clamping member. Beyond this ear 16, the movable clamping plate is bent curvingly upon itself in the direction of the upstanding flange 12 and has such position with respect to said upstanding flange, that when reins are disposed between it and the upstanding flange, the movable clamping plate may be swung upon its pivot to tightly grip the reins between this curvingly bent gripping end portion and the upstanding flange. The overhanging portion 13 of the upstanding flange, serves to prevent upward movement of the reins from between the two clamping members when the latter are in active relation. At the opposite end of the flange 15 from the ear 16, said flange is bent downwardly beyond the plate 10 and is beveled to form a tooth 18, and in the plate 10 are formed a series of perforations 20 disposed to interchangeably receive this tooth 18 and hold the movable clamping member in different positions or at different points of its pivotal movement. The movable clamping plate is continued beyond the flange 16 a sufficient distance to project over the end of the plate 10 and form a handle by means of which it may be manipulated. This movable clamping plate is formed of a material having more or less spring quality so that the curved gripping jaw portion thereof may be pressed firmly against the reins to put it under tension and thus compensate for any flattening of the reins so that slipping of the reins is positively prevented.

It will thus be seen that the present device consists of only three parts, namely, the supporting plate 10, the movable clamping plate, and the rivets. This not only facilitates the manufacture of the article but permits it to be made at an extremely low price while its efficiency is unquestioned.

What is claimed is—

1. A rein holder comprising a base plate having a clamping flange, a clamping member pivoted to the base plate and movable into and out of clamping relation to the flange, said clamping member having an operating handle provided with a depending ear, said base plate having a series of per-

forations disposed to successively receive the ear of the handle.

2. A rein holder comprising a base plate having a clamping flange, a clamping member consisting of a plate provided with a laterally bent flange, a pivot engaged through said laterally bent flange and base plate, said laterally bent flange having its opposite end portion from the pivot bent downwardly, and said base plate having a series of perforations disposed to interchangeably receive said downwardly bent portion of the flange.

3. A rein holder comprising a base plate having at one longitudinal edge an upwardly extending flange extending at an angle to the base plate and having its upper edge portion extending over the base plate in parallel relation thereto, a movable clamping member consisting of a spring

metal plate having one end portion bent upon itself in curved shape, and in position to clamp an article against said flange, said spring metal plate having at one longitudinal edge an outward flange, one end portion of which is bent downwardly, said base plate having a series of perforations disposed to interchangeably receive said downwardly bent portion of said flange of the spring metal plate, and a pivot engaged through the opposite end portion of the flange of the spring metal plate and engaged in the base plate.

In testimony whereof, I affix my signature, in presence of two witnesses.

HOWARD J. YOUNT.

Witnesses:

CHARLES A. CANTRAY,
IDA HEDRICK.