

*E. E. Hendrick. Sheet 1 of 3 Sheets.  
Hand Stamp.*

*No. 104,148. Patented Jun. 14, 1870.*

*Fig. 1.*

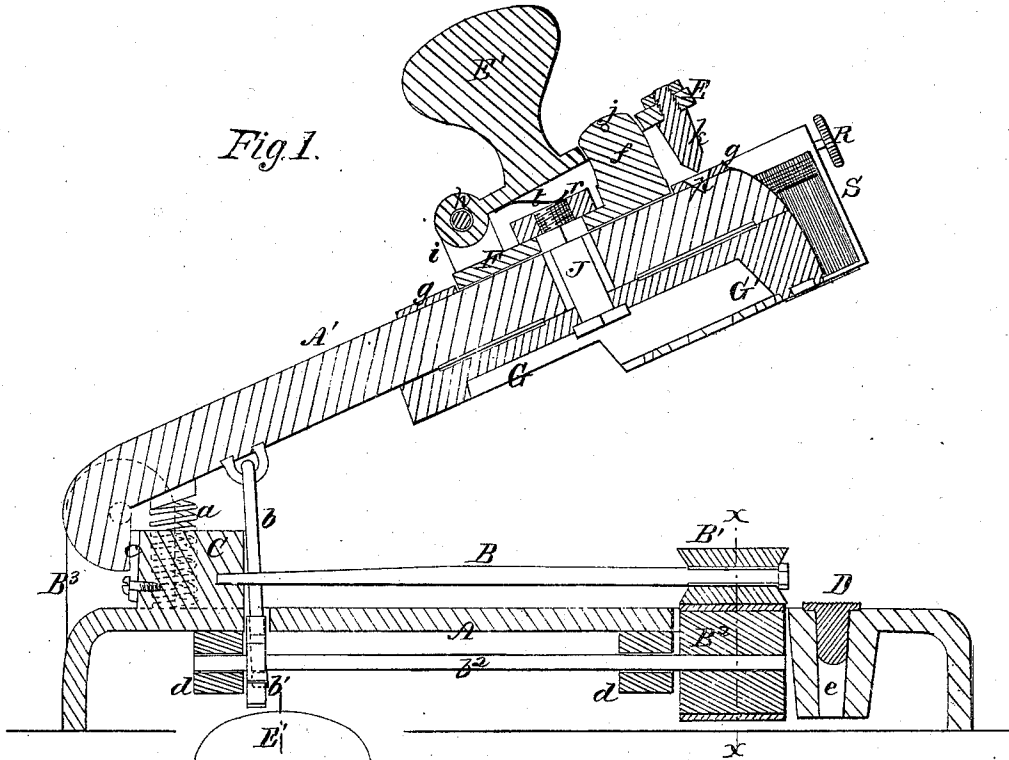

*Fig. 2.*

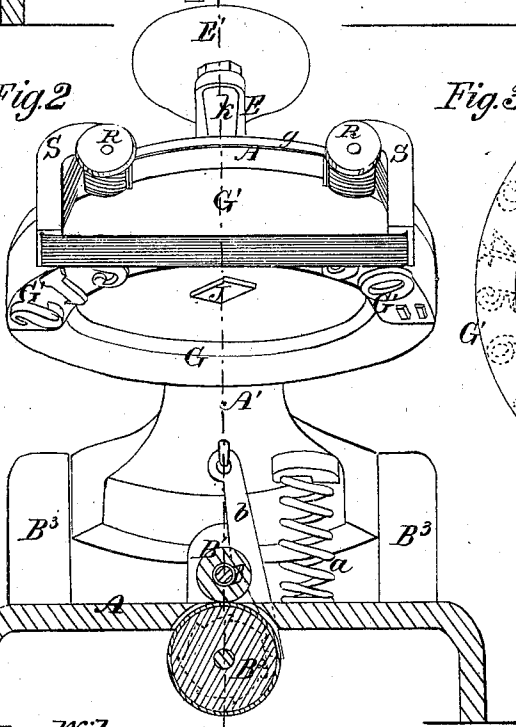

*Fig. 3.*

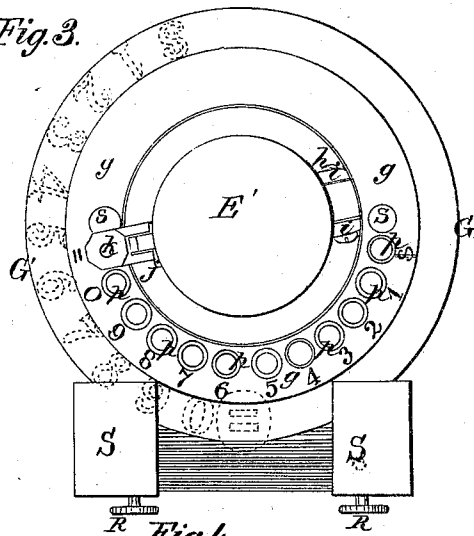

*Fig. 4.*



*Witnesses.  
R. J. Campbell  
J. N. Campbell.*

*Inventor.  
E. E. Hendrick  
by  
Mann, Fenwick & Lawrence.*

*E. E. Hendrick. Sheet 2 of 3 Sheets.*

*Hand Stamp.*

*No. 104,148.*

*Patented Jun. 14, 1870.*

*Fig. 5.*

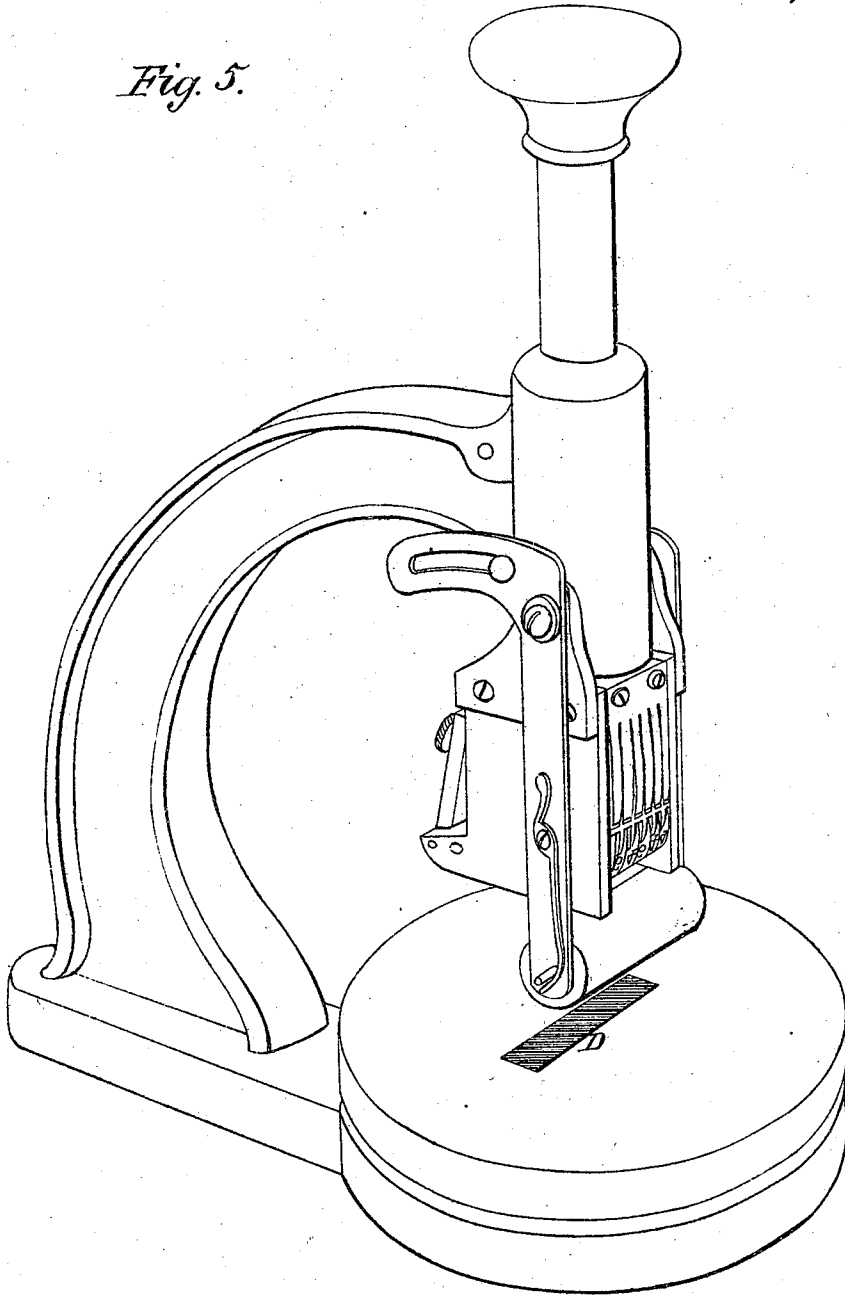

*Witnesses*

*R. T. Campbell -  
J. V. Campbell*

*Inventor*

*E. E. Hendrick  
by  
Massey, Hendrick & Lawrence.*

*E. E. Hendrick. Sheet 3 of 3 Sheets.*

*Hand Stamp.*

*No. 104,148. Patented Jun. 14, 1870.*

*Fig. 6.*

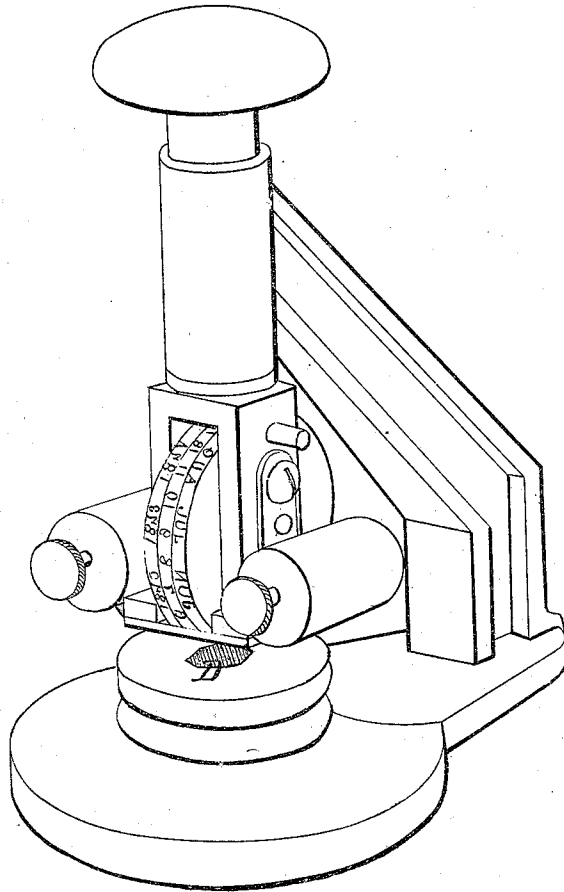

*Witnesses.*  
*R. T. Campbell*  
*J. H. Campbell*

*Inventor.*  
*E. E. Hendrick*  
*by*  
*Wm. Hendrick Hamess.*

# United States Patent Office.

ELI E. HENDRICK, OF CARBONDALE, PENNSYLVANIA.

Letters Patent No. 104,148, dated June 14, 1870.

## IMPROVEMENT IN STAMP-CANCELLERS.

The Schedule referred to in these Letters Patent and making part of the same.

To all whom it may concern :

Be it known that I, ELI E. HENDRICK, of Carbondale, in the county of Luzerne and State of Pennsylvania, have invented a new and useful Improvement, which is designed for Printing by Cutting or Perforating Letters or other Characters; and I do hereby declare that the following is a full, clear, and exact description thereof, reference being had to the accompanying drawing making part of this specification, in which—

Figure 1, sheet 1, is a longitudinal section taken vertically through the center of a machine having my improvement applied to it.

Figure 2, sheet 1, is a front view of the machine and section through the feed-rollers and bed-plate.

Figure 3, sheet 1, is a top view of the type-head and register.

Figure 4, sheet 1, is a top view of a cutting platen.

Figure 5, sheet 2, is a perspective view of a hand printing stamp having my invention applied to it.

Figure 6, sheet 3, is a perspective view of another form of stamp having my invention applied to it.

Similar letters of reference indicate corresponding parts in the several figures.

This invention is designed for stamping in an indelible manner any instrument or commercial paper with such figures or other characters as will denote the value written or printed upon the paper; also, for canceling revenue or other stamps in such manner as will effectually prevent an erasure or obliteration of the cancellation.

The nature of my invention consists in a platen which has its face made up of cutting edges or points, and adapted for use in combination with types, for the purpose of producing the desired letters, figures, or other characters in paper, by cutting through the paper, as will be hereinafter explained.

To enable others skilled in the art to understand my invention, I will describe its construction and operation.

In the accompanying drawing I have represented my invention applied to three different forms of hand-stamps, but I do not intend confining myself to its application to these forms of stamps, as I believe that I am the first to have made a platen serve as a cutter or perforator for paper, during the act of printing, and at the same time serve as a bed upon which the printing-types strike.

The machines or stamps represented on sheets 2 and 3 of the drawing are well known and in common use, and need not be described further than to state that the bed or platen D, which is arranged beneath the types, has its surface made up of parallel cutting-

edges, which will cut through paper laid upon it when the type-heads are brought down with a quick motion.

The machine or stamp which is represented on sheet 1 of the drawing is somewhat different in the construction and arrangement of its several parts from any machine of its kind.

The platen D is secured into a recess, *e*, made in the upper surface of the plate A, and this platen is so arranged with reference to the type, which is adjusted in position for printing, that when the free end of the arm A is depressed such type will strike squarely upon said platen.

This platen is made of steel, with its upper surface serrated, so as to leave a great number of sharp cutting-edges, as shown in figs. 1 and 4, which edges will cut through the paper during the act of printing, and thus so effectually destroy the fibers of that part of it printed upon as to effectually prevent successful repair or erasure, and while this is the case, the paper, where it is thus printed upon, will be smooth, and any matter which may have been previously written or printed upon it will not be rendered indistinct.

I have thus described a platen which is made to present parallel cutting-edges which will produce long cuts in parallel lines through paper, but it is obvious that, instead of cutting-edges, points or spurs might be produced upon the surface of the platen, which would produce perforations through paper corresponding in arrangement to the outline of the types used.

I am aware that types have been produced of a great number of fine points or punches, and used in combination with a soft platen for pricking letters, figures, and other characters, through paper, but owing to the liability of such types becoming injured by the breaking of their points, and for other reasons, such types are objectionable. Whereas, by making the surfaces of the platens or beds upon which the printing is perforated, so as to prevent cutting or perforating points, edges, or elevations, the objections above alluded to are removed, and should the cutting or perforating-surfaces on a platen become dulled, a new platen substituted in its place will repair the machine.

Having described my invention,

What I claim as new, and desire to secure by Letters Patent, is—

Providing any description of printing apparatus with a platen having a cutting, perforating, or scari-fying surface, substantially as set forth.

E. E. HENDRICK.

Witnesses:

JULIUS HIRSCH,  
R. T. CAMPBELL.