



US011427261B2

(12) **United States Patent**
Naito et al.

(10) **Patent No.:** **US 11,427,261 B2**

(45) **Date of Patent:** **Aug. 30, 2022**

(54) **VEHICLE BODY STRUCTURE AND METHOD FOR MANUFACTURING VEHICLE BODY**

(71) Applicant: **NISSAN MOTOR CO., LTD.**,
Yokohama (JP)

(72) Inventors: **Tetsuro Naito**, Kanagawa (JP);
Toshikazu Torigaki, Kanagawa (JP);
Shinichirou Takemoto, Kanagawa (JP);
Katsumi Morohoshi, Kanagawa (JP)

(73) Assignee: **NISSAN MOTOR CO., LTD.**,
Yokohama (JP)

(*) Notice: Subject to any disclaimer, the term of this patent is extended or adjusted under 35 U.S.C. 154(b) by 0 days.

(21) Appl. No.: **15/734,684**

(22) PCT Filed: **Jun. 5, 2018**

(86) PCT No.: **PCT/JP2018/021436**

§ 371 (c)(1),

(2) Date: **Dec. 3, 2020**

(87) PCT Pub. No.: **WO2019/234804**

PCT Pub. Date: **Dec. 12, 2019**

(65) **Prior Publication Data**

US 2021/0229756 A1 Jul. 29, 2021

(51) **Int. Cl.**

B60J 9/00 (2006.01)

B62D 29/00 (2006.01)

(Continued)

(52) **U.S. Cl.**

CPC **B62D 29/001** (2013.01); **B62D 25/025** (2013.01); **B62D 65/02** (2013.01)

(58) **Field of Classification Search**

CPC .. **B62D 25/025**; **B62D 25/04**; **B62D 25/2036**;
B62D 21/157; **B62D 25/2018**; **B61D**
7/00; **E21D 23/0409**; **Y02P 70/50**

See application file for complete search history.

(56) **References Cited**

U.S. PATENT DOCUMENTS

8,366,185 B2* 2/2013 Heritier B62D 21/157
296/187.12

8,985,681 B2* 3/2015 Fujii B62D 25/2036
296/204

(Continued)

FOREIGN PATENT DOCUMENTS

CN 104024093 A 9/2014

DE 102006052643 A1 4/2008

(Continued)

Primary Examiner — Kiran B Patel

(74) Attorney, Agent, or Firm — Foley & Lardner LLP

(57) **ABSTRACT**

A vehicle body structure includes a resin floor part provided with a flange portion bent toward an upper side or a lower side at an end in a vehicle width direction, and a metal side sill part joined to the flange portion of the floor part. The side sill part includes a rim portion, a peak portion, and intermediate portions that link the rim portion to the peak portion. The peak portion and the intermediate portions form a protruding portion projecting from the rim portion toward the floor part. The flange portion of the floor part is joined to the peak portion of the protruding portion.

11 Claims, 8 Drawing Sheets

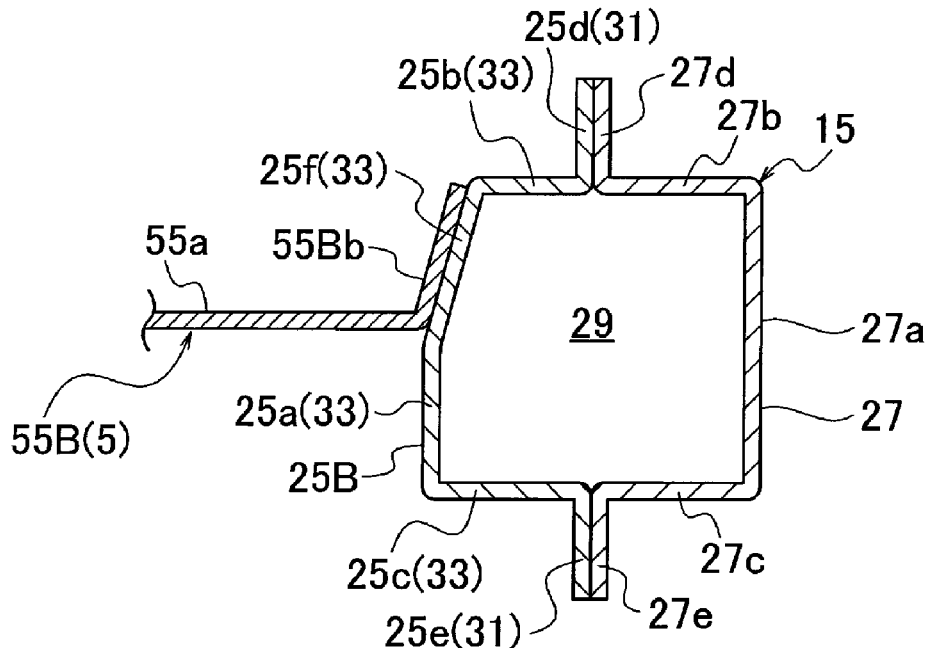

- (51) **Int. Cl.**
B62D 25/02 (2006.01)
B62D 65/02 (2006.01)

(56) **References Cited**

U.S. PATENT DOCUMENTS

9,139,234 B2 * 9/2015 Mori B62D 25/025
9,205,876 B2 12/2015 Goto
9,981,699 B2 * 5/2018 Ayuzawa B32B 3/26
2013/0242487 A1 9/2013 Fujioka et al.
2014/0367996 A1 12/2014 Goto
2016/0016359 A1 1/2016 Kondo et al.
2016/0221609 A1 8/2016 Furusaki et al.
2016/0272248 A1 9/2016 Furusaki et al.
2017/0011730 A1 1/2017 Seto et al.

FOREIGN PATENT DOCUMENTS

JP 60-38874 U 3/1985
JP 62-102778 U 6/1987
JP 62-175269 A 7/1987
JP 64-22681 A 1/1989
JP 7-132860 A 5/1995
JP 7-277228 A 10/1995
JP 2008-068720 A 3/2008
JP 2009-190696 A 8/2009
JP 2012-111247 A 6/2012
JP 2012-206504 A 10/2012
JP 2013-163465 A 8/2013
WO WO 2014/142189 A1 9/2014
WO WO 2015/115647 A1 8/2015

* cited by examiner

FIG. 3

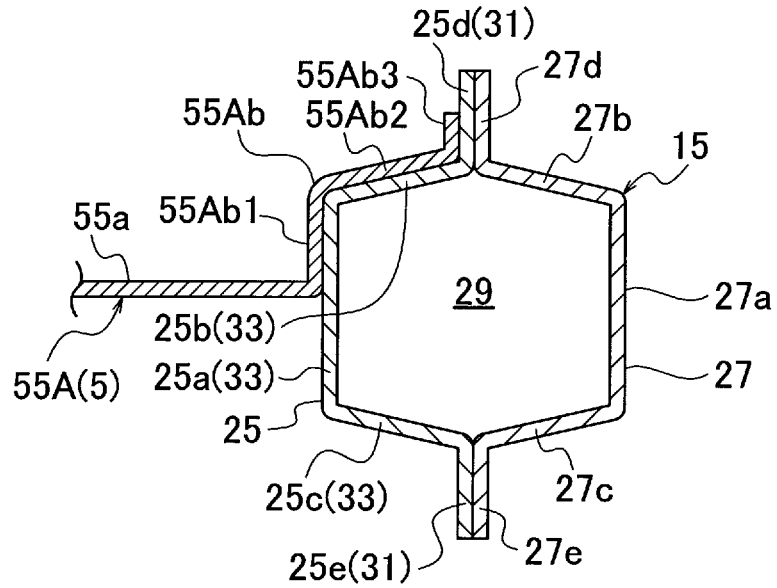

FIG. 4

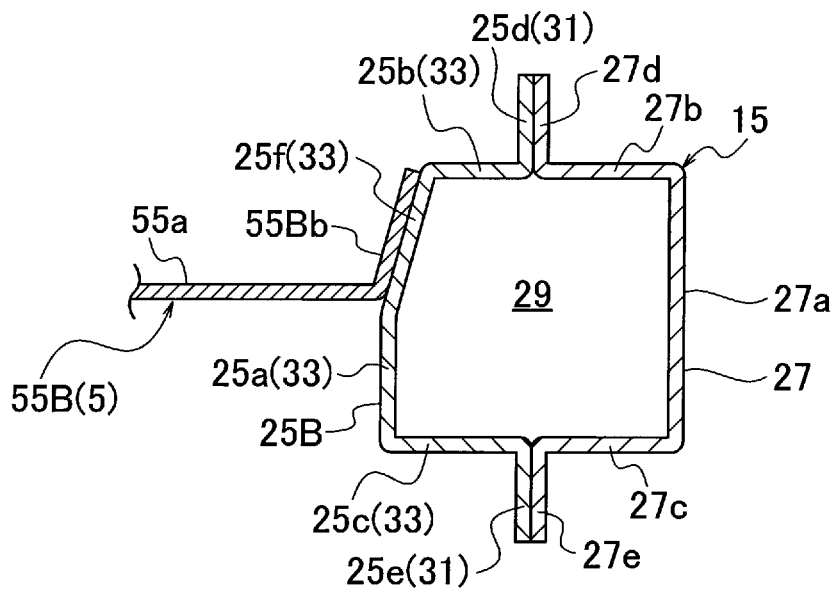

FIG. 5

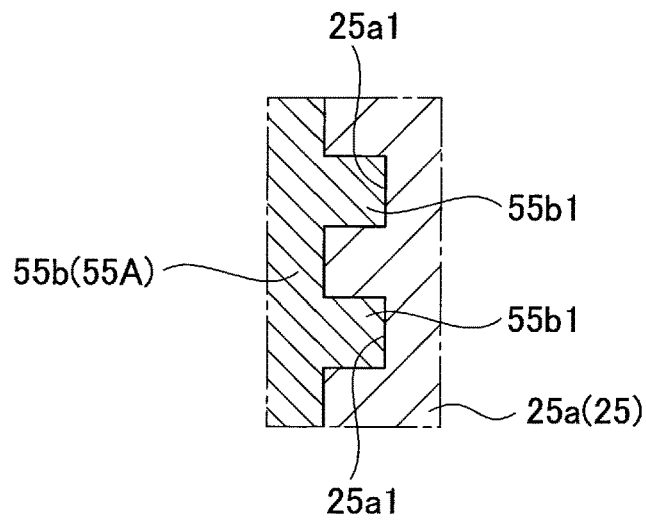

FIG. 6

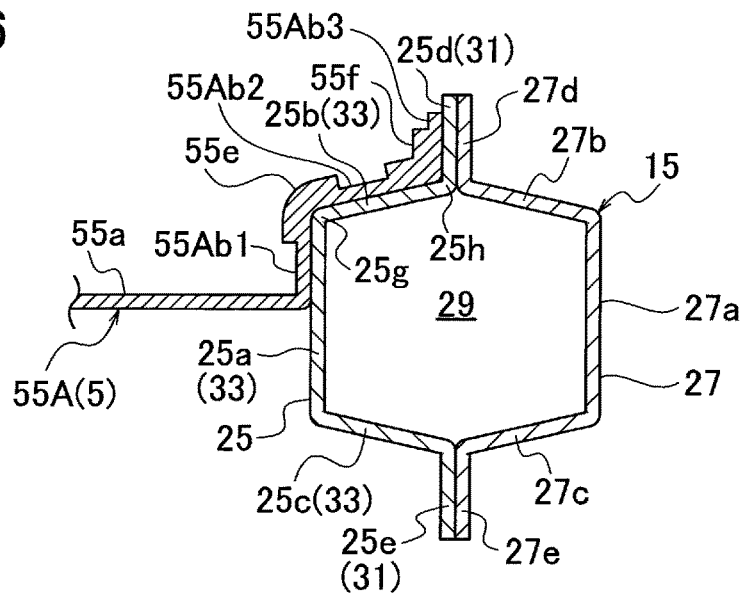

FIG. 7

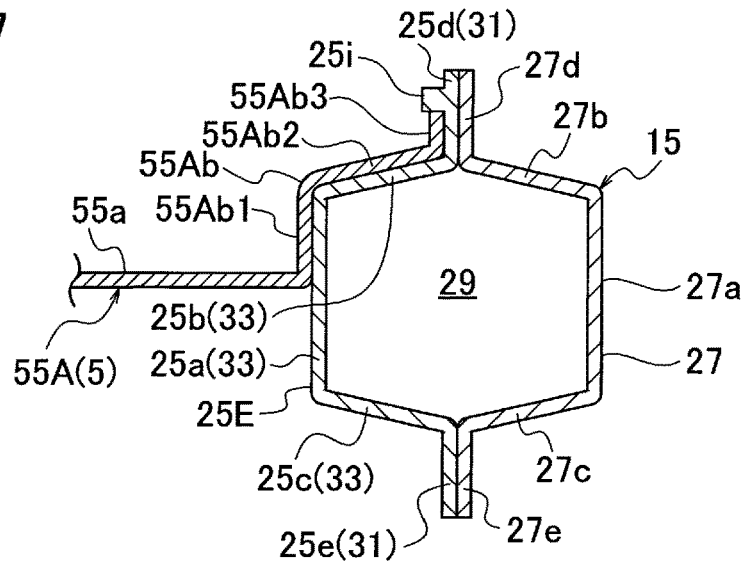

FIG. 8

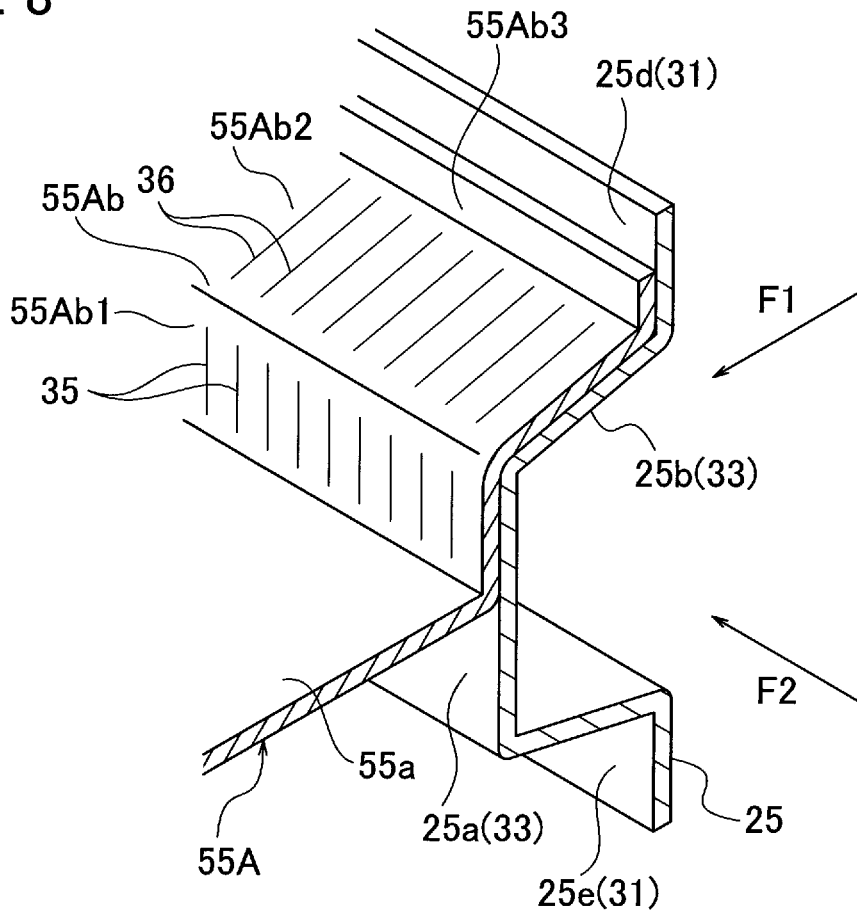

FIG. 9

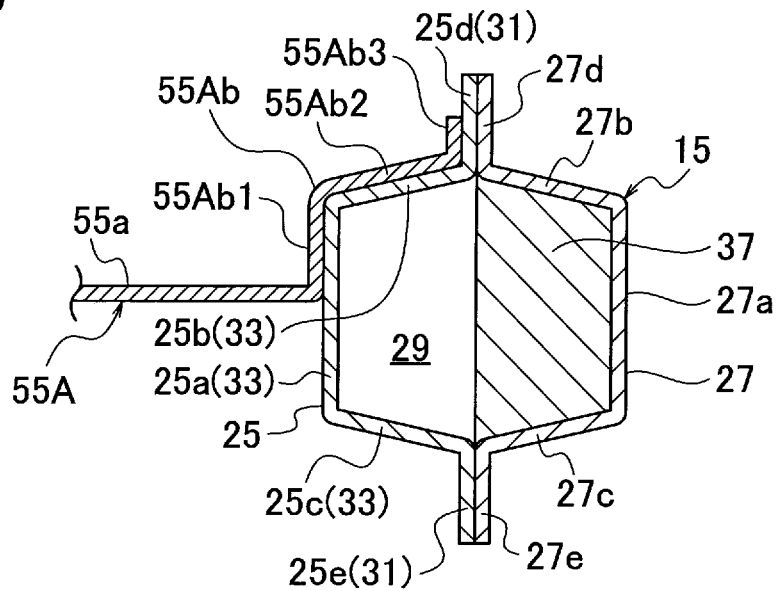

FIG. 12

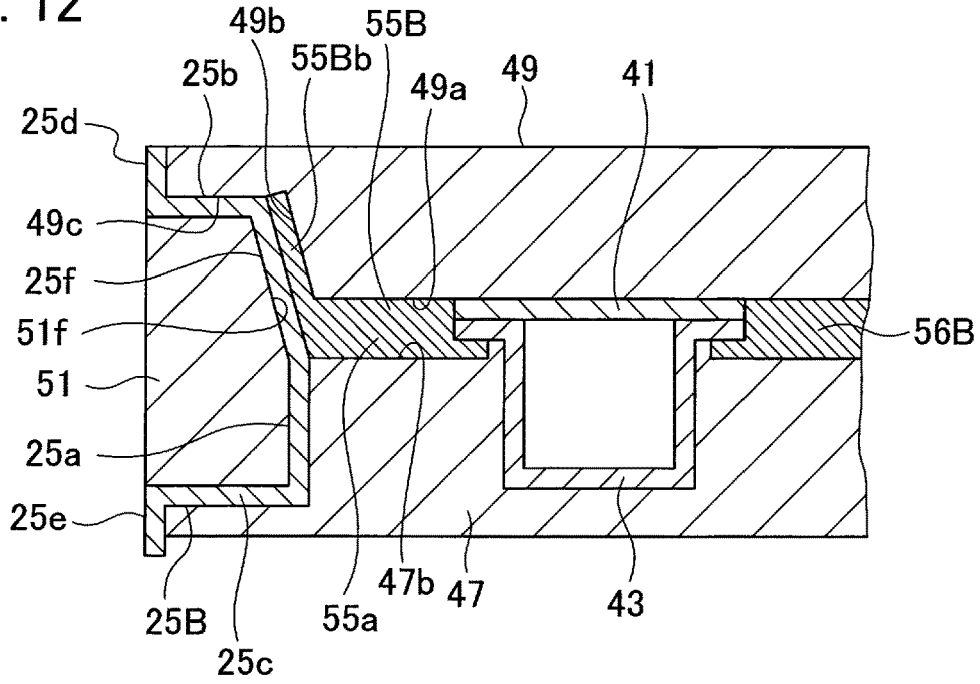

FIG. 13

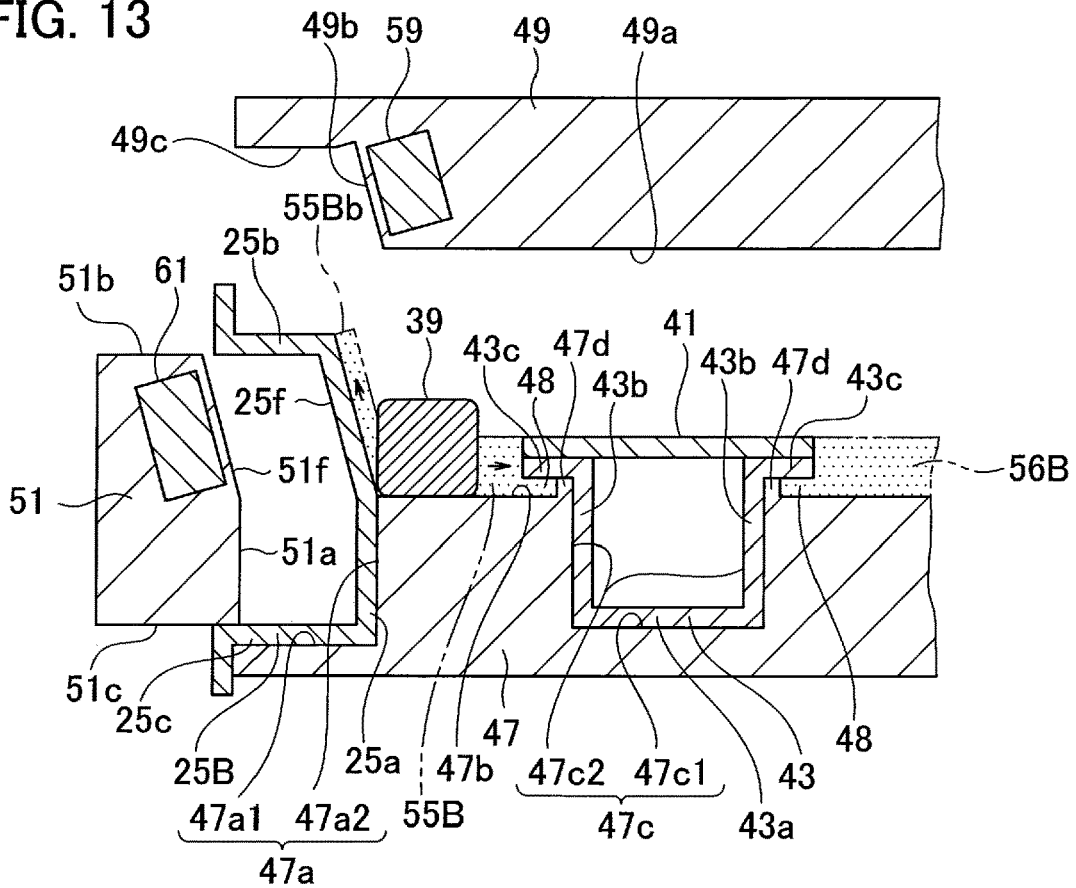

FIG. 14

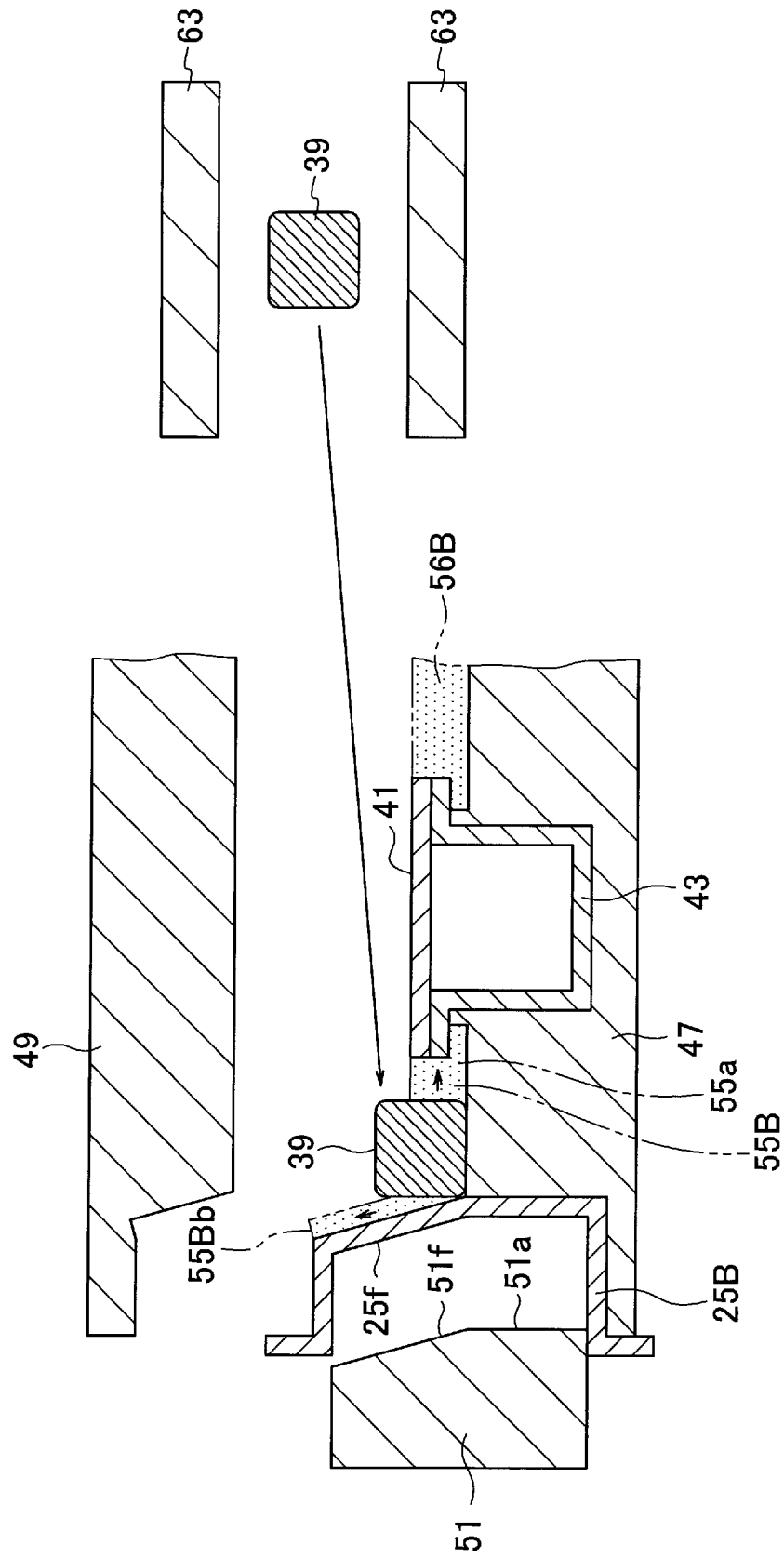

FIG. 15

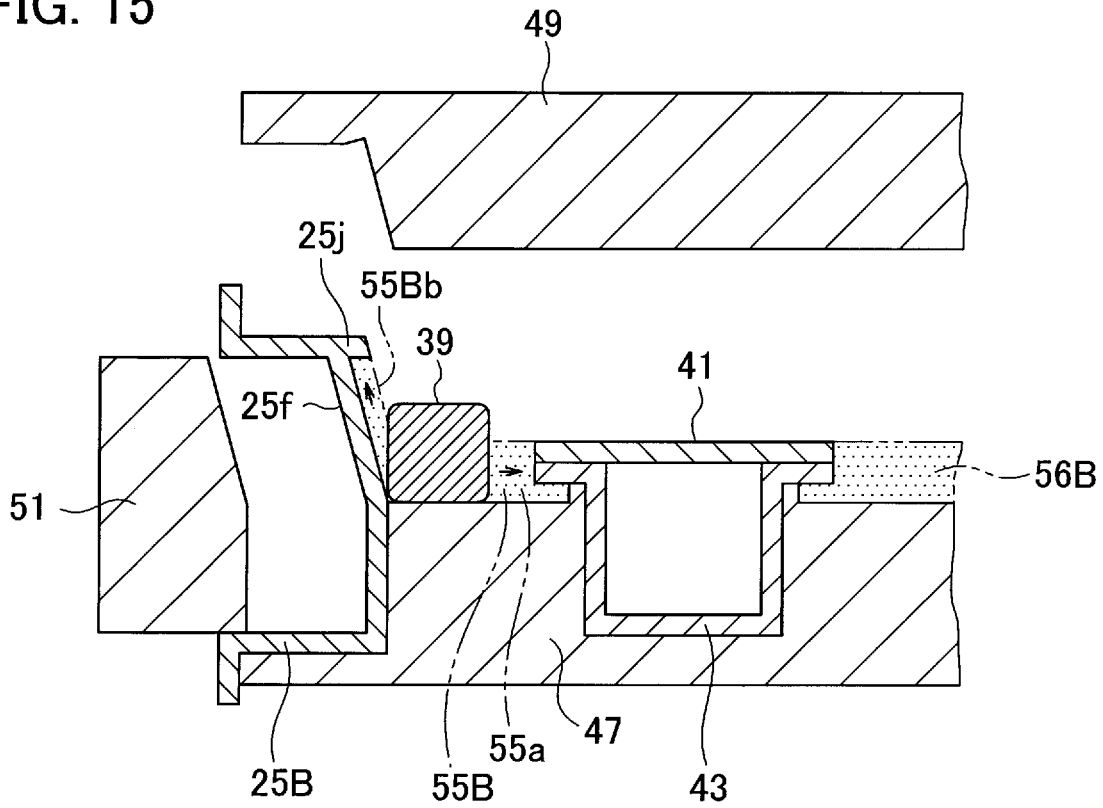
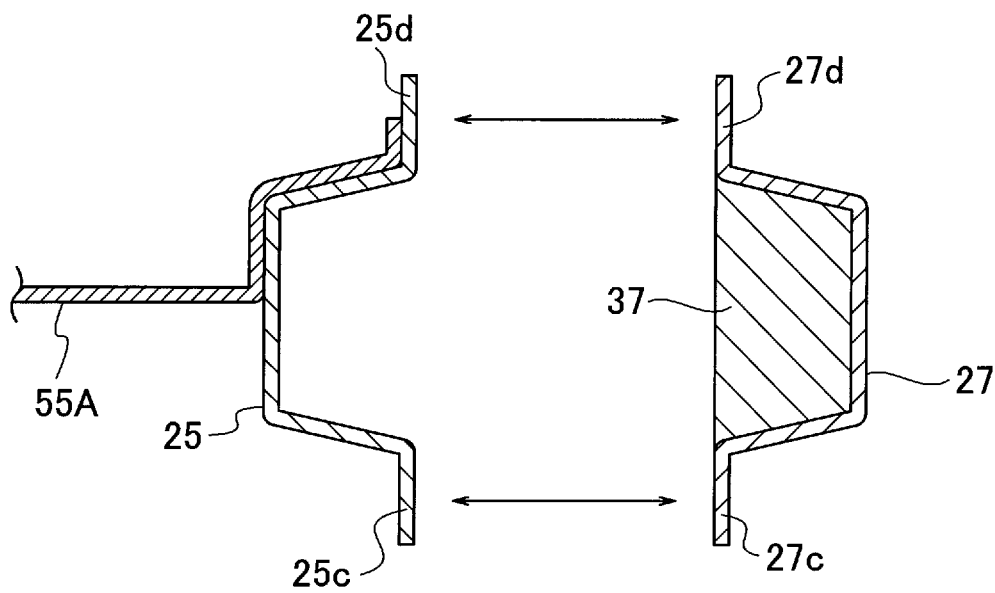

FIG. 16



1

VEHICLE BODY STRUCTURE AND METHOD FOR MANUFACTURING VEHICLE BODY

TECHNICAL FIELD

The present invention relates to a vehicle body structure in which a floor part is joined to a side sill part, and to a method for manufacturing a vehicle body.

BACKGROUND ART

A technique disclosed in Patent Literature 1 has been known as a structure to join a floor panel to a side sill. In the structure according to Patent Literature 1, both the floor panel and the side sill are formed from metal parts and are joined to each other by welding.

CITATION LIST

Patent Literature

Patent Literature 1: Japanese Patent Application Publication No. 2013-163465

SUMMARY OF INVENTION

Technical Problem

The structure according to Patent Literature 1 involves the joining of the metal parts and can therefore employ the welding method. Meanwhile, it is not possible to employ the joining method by means of welding when a portion of the floor panel to be joined to the side sill is formed from a resin. For this reason, in order to join the side sill made of a metal to the floor panel made of a resin, it is necessary to improve rigidity around a junction by further increasing a junction area.

In view of the above, an object of the present invention is to improve rigidity around a junction by further increasing a junction area between a side sill part made of a metal and a floor part made of a resin.

Solution to Problem

In a vehicle body structure according to an aspect of the present invention, a resin floor part includes a flange portion that is formed to be bent toward an upper side or a lower side at an end in a vehicle width direction, and a metal side sill part includes a protruding portion that projects from a rim portion toward the floor part. The flange portion of the floor part is joined to a peak portion of the protruding portion of the side sill part.

ADVANTAGEOUS EFFECTS OF INVENTION

According to the present invention, it is possible to improve rigidity around a junction by further increasing a junction area between a side sill part made of a metal and a floor part made of a resin.

BRIEF DESCRIPTION OF DRAWINGS

FIG. 1 is a perspective view showing a vehicle body structure according to a first embodiment.

FIG. 2 is a cross-sectional view taken along the A-A line in FIG. 1.

2

FIG. 3 is a cross-sectional view corresponding to FIG. 2, which shows a second embodiment.

FIG. 4 is a cross-sectional view corresponding to FIG. 2, which shows a third embodiment.

5 FIG. 5 is an enlarged cross-sectional view of part B in FIG. 2, which shows a fourth embodiment.

FIG. 6 is a cross-sectional view corresponding to FIG. 2, which shows a fifth embodiment.

10 FIG. 7 is a cross-sectional view corresponding to FIG. 2, which shows a sixth embodiment.

FIG. 8 is a perspective view showing orientations of fiber-reinforcement materials at a floor panel side portion of a seventh embodiment.

15 FIG. 9 is a cross-sectional view corresponding to FIG. 2, which shows an eighth embodiment.

FIG. 10 is a perspective view showing a region around a side sill on a left side in a vehicle width direction in the vehicle body structure of FIG. 1.

20 FIG. 11 is a cross-sectional view before molding according to a ninth embodiment showing a portion corresponding to a B-B cross-sectional structure in FIG. 10 inclusive of molds.

FIG. 12 is a cross-sectional view showing a state after the molding in contrast to FIG. 11.

25 FIG. 13 is a cross-sectional view according to a tenth embodiment, in which heaters are attached to an upper mold and to a slide mold in contrast to FIG. 11, respectively.

30 FIG. 14 is a cross-sectional view according to an eleventh embodiment configured to preheat a resin with a heating device instead of providing the heaters of FIG. 13.

35 FIG. 15 is a cross-sectional view according to a twelfth embodiment configured to provide an upper part of an inclined wall of a side sill inner member with a protrusion that projects to an inner side in the vehicle width direction in contrast to FIG. 11.

FIG. 16 is a cross-sectional view according to a thirteenth embodiment configured to join a side sill outer member to the side sill inner member.

DESCRIPTION OF EMBODIMENTS

Embodiments of the present invention will be described below with reference to the drawings.

First Embodiment

45 A vehicle body structure according to a first embodiment will be described with reference to FIG. 1. FIG. 1 shows a vehicle body structure of an automobile. In FIG. 1, a direction indicated with an arrow FR represents a front side of a vehicle body, a direction indicated with an arrow UP represents an upper side of the vehicle body, and a direction indicated with an arrow LH represents a left side of the vehicle body.

50 A vehicle body 1 includes right and left body side panels 3, a floor panel 5, and a roof panel 7. A vehicle interior 9 is formed inside surrounded by these panels 3, 5, and 7. A motor (engine) room 13 is formed in front of the vehicle interior 9 while interposing a dash panel 11 in between. Each body side panel 3 includes a side sill 15 located at a lower part of the vehicle body, a roof side rail 17 located at an upper part of the vehicle body, a front pillar 19 located at a front part of the vehicle body, a rear pillar 21 located at a rear part of the vehicle body, and a center pillar 23 located at the center in a vehicle body front-rear direction.

65 The side sill 15 and the roof side rail 17 extend in the vehicle body front-rear direction. The front pillar 19, the rear

3

pillar 21, and the center pillar 23 extend in a vehicle body up-down direction. The front pillar 19 connects front ends of the side sill 15 and of the roof side rail 17 to each other, the rear pillar 21 connects rear ends thereof to each other, and the center pillar 23 connects central parts thereof to each other, respectively. The side sill 15 is joined and fixed to the floor panel 5 and the roof side rail 17 is joined and fixed to the roof panel 7.

As shown in FIG. 2 that represents a cross-sectional view taken along the A-A line in FIG. 1, the side sill 15 includes a side sill inner member 25 serving as a side sill part and a side sill outer member 27 serving as a second side sill part, each of which is molded by pressing a metal panel material formed from a steel plate, aluminum, or the like. The side sill inner member 25 is located on an inner side in a vehicle width direction of the side sill outer member 27 while the side sill outer member 27 is located on an outer side in the vehicle width direction of the side sill inner member 25.

The side sill inner member 25 includes a side wall 25a as a peak portion that extends in an up-down direction, an upper wall 25b as an upper surface portion that is bent slightly obliquely upward on an outer side in the vehicle width direction from an upper end of the side wall 25a, and a lower wall 25c as a lower surface portion that is bent slightly obliquely downward on the outer side in the vehicle width direction from a lower end of the side wall 25a. An end of the upper wall 25b on an opposite side of the side wall 25a forms an upper flange 25d that is bent upward and an end of the lower wall 25c on an opposite side of the side wall 25a forms a lower flange 25e that is bent downward.

The side sill outer member 27 includes a side wall 27a that extends in the up-down direction, an upper wall 27b that is bent slightly obliquely upward on an inner side in the vehicle width direction from an upper end of the side wall 27a, and a lower wall 27c that is bent slightly obliquely downward on the inner side in the vehicle width direction from a lower end of the side wall 27a. An end of the upper wall 27b on an opposite side of the side wall 27a forms an upper flange 27d that is bent upward and an end of the lower wall 27c on an opposite side of the side wall 27a forms a lower flange 27e that is bent downward. The upper flanges 25d and 27d are joined and fixed to each other by welding and the lower flanges 25e and 27e are joined and fixed to each other by welding, thus forming the side sill 15. A closed cross-sectional portion 29 is formed inside the side sill 15.

The floor panel 5 includes a floor panel side portion 55 as a floor part to be joined to the side sill 15. The floor panel side portion 55 is a composite material formed by mixing a fiber-reinforcement material such as carbon fibers with a thermoplastic resin such as polyamide, for example. The floor panel side portion 55 does not always have to contain the fiber-reinforcement material. The floor panel side portion 55 includes a bottom wall 55a formed into a substantially horizontal surface, and a flange portion 55b formed to be bent toward an upper side at an angle of about 90° from an end in the vehicle width direction of the bottom wall 55a.

The flange portion 55b is attached to an upper part of the side wall 25a of the side sill inner member 25. When the floor panel side portion 55 is molded integrally with the side sill inner member 25, the flange portion 55b is joined and attached closely to the side wall 25a of the side sill 15. Here, without limitation to the upper part of the side wall 25a, the flange portion 55b may be attached to the center or a lower part in the up-down direction of the side wall 25a, or to the entire side wall 25a. The flange portion 55b may be bent toward a lower side from the bottom wall 55a. In other words, the side sill inner member 25 includes the flange

4

portion which is formed to be bent toward the upper side or the lower side at an end in the vehicle width direction.

In the side sill inner member 25, the upper flange 25d and the lower flange 25e constitute a rim portion 31, and a protruding portion 33 is formed to project from the rim portion 31 toward the floor panel side portion 55. The protruding portion 33 is formed from the side wall 25a, the upper wall 25b, and the lower wall 25c. The upper wall 25b and the lower wall 25c form an intermediate portion that links the rim portion 31 to the peak portion 25a.

This embodiment includes the floor panel side portion 55 made of a resin and provided with the flange portion 55b that is bent toward the upper side or the lower side at the end in the vehicle width direction, and the side sill inner member 25 made of a metal and joined to the floor panel side portion 55 made of the resin at the flange portion 55b. The side sill inner member 25 includes the rim portion 31, the peak portion 25a, and the upper wall 25b as well as the lower wall 25c which link the rim portion 31 to the peak portion 25a. The peak portion 25a, the upper wall 25b, and the lower wall 25c form the protruding portion 33 that projects from the rim portion 31 toward the floor panel side portion 55. The flange portion 55b of the floor panel side portion 55 is joined to the side wall 25a of the protruding portion 33.

In this case, the flange portion 55b of the floor panel side portion 55 is joined in such a way as to butt against the side wall 25a of the protruding portion 33 of the side sill inner member 25. The flange portion 55b makes it possible to secure a larger junction area between the floor panel side portion 55 and the side sill inner member 25 and junction strength is thus improved.

When the flange portion 55b is joined and fixed to the side sill inner member 25 is used as part of the side sill 15, a thickness in the vehicle width direction of the side sill 15 becomes larger in an amount equivalent to an additional thickness of the flange portion 55b whereby a cross-sectional shape of the side sill 15 is increased. This makes it possible to improve rigidity of the side sill 15 being a region around a junction of the side sill inner member 25 and the floor panel side portion 55. As a consequence of the increase in thickness in the vehicle width direction of the side sill 15, rigidity against a load from a lateral side of the vehicle (hereinafter referred to as a lateral collision load) is particularly improved.

Second Embodiment

FIG. 3 shows a vehicle body structure according to a second embodiment. In the second embodiment, a shape of a floor panel side portion 55A is different from that of the first embodiment. The side sill 15 is the same as that of the first embodiment. As with the floor panel side portion 55 of the first embodiment, the floor panel side portion 55A includes the bottom wall 55a and a flange portion 55Ab.

The flange portion 55Ab includes a floor side wall 55Ab1 formed to be bent toward the upper side at an angle of about 90° from an end in the vehicle width direction of the bottom wall 55a. The flange portion 55Ab further includes a floor upper wall 55Ab2 that is bent and extends slightly obliquely upward on the outer side in the vehicle width direction from an upper end of the floor side wall 55Ab1, and a floor end wall 55Ab3 that is bent and extends upward from an end of the floor upper wall 55Ab2 on an opposite side of the floor side wall 55Ab1.

The floor side wall 55Ab1 is joined to an upper part of the side wall 25a of the side sill inner member 25. The floor upper wall 55Ab2 is lapped over and joined to the upper wall

5

25b of the protruding portion **33**. The floor end wall **55Ab3** is joined to the upper flange **25d**. As with the floor panel side portion **55** in FIG. 2, the floor panel side portion **55A** is molded from a resin-containing material integrally with the side sill inner member **25**. Here, the floor end wall **55Ab3** is dispensable.

According to the second embodiment, the intermediate portion that links the rim portion **31** to the peak portion **25a** is formed from the upper wall **25b** at the upper part of the vehicle body and the lower wall **25c** at the lower part of the vehicle body. The flange portion **55Ab** is formed to be bent toward the upper side, and the floor upper wall **55Ab2** is joined to the upper wall **25b**. In this case, the floor upper wall **55Ab2** and the floor end wall **55Ab3** that are formed in conformity to the shape of the side sill inner member **25** are joined to the upper wall **25b** and the upper flange **25d**, respectively. Thus, the junction area is further expanded and the junction strength is further improved. The rigidity against a lateral collision load is improved as well. Due to the state of placing the floor upper wall **55Ab2** on the upper wall **25b** of the side sill inner member **25**, a binding force in the up-down direction between the side sill inner member **25** and the floor panel side portion **55A** is increased.

Third Embodiment

FIG. 4 shows a vehicle body structure according to a third embodiment. In the third embodiment, a shape of a side sill inner member **25B** is different from that of the first embodiment. In the side sill inner member **25B**, an inclined wall **25f** is provided to an upper part of the side wall **25a**. The inclined wall **25f** is inclined such that its upper part is located on the outer side in the vehicle width direction (the right side in FIG. 4) as compared to its lower side. A flange portion **55Bb** of a floor panel side portion **55B** is inclined such that its upper part is located on the outer side in the vehicle width direction as compared to its lower side so as to correspond to the inclined wall **25f**.

As with the floor panel side portion **55** in FIG. 2, the floor panel side portion **55B** is molded from a resin-containing material integrally with the side sill inner member **25B**. The upper wall **25b** and the lower wall **25c** of the side sill inner member **25B**, and the upper wall **27b** and the lower wall **27c** of the side sill outer member **27** shown in FIG. 4 are set horizontal, respectively. Instead, any of these walls may be inclined like the side sill inner member **25** in FIG. 2. In the floor panel side portion **55B** of FIG. 4, the flange portion **55Bb** may include a floor upper wall and a floor end wall like the floor upper wall **55Ab2** and the floor end wall **55Ab3** of the floor panel side portion **55A** in FIG. 3.

According to the third embodiment, the side wall **25a** to be joined to the flange portion **55Bb** includes the inclined wall **25f** that is inclined relative to a vertical direction. In this case, when a pressure in the up-down direction in FIG. 4 is applied to the resin supplied into molds, a pressure in the up-down direction is more likely to act in the joining direction between the flange portion **55b** and the inclined wall **25f**. As a consequence, the junction strength between the floor panel side portion **55** and the side sill inner member **25** is further improved. Since the inclined wall **25f** is formed by inclining part of the side wall **25a** toward the outer side in the vehicle width direction, a space in the vehicle interior **9** becomes larger as compared to FIGS. 2 and 3.

Fourth Embodiment

FIG. 5 shows a fourth embodiment. FIG. 5 is an enlarged cross-sectional view of part B in FIG. 2, for example, in

6

which dents **25a1** are formed in a surface on the floor panel side portion **55A** side of the side wall **25a** of a side sill inner member **25A**. In this way, the surface on the floor panel side portion **55A** side of the side wall **25a** is formed into an indented surface. A resin-containing material enters the dents **25a1** at the time of integrally molding the floor panel side portion **55A**, whereby resin bulges **55b1** are formed on the flange portion **55b**. For example, the indented surface of the side wall **25a** can be processed by a waterjet treatment, a chemical conversion treatment, a laser beam treatment, a thermal spray treatment, and the like.

According to the fourth embodiment, an indented structure that is smaller than the protruding portion **33** is formed on the surface of the side sill inner member **25** to be joined to the floor panel side portion **55A**. As a consequence, the junction area between the side sill inner member **25** and the floor panel side portion **55A** is further increased and the junction strength is further improved.

Fifth Embodiment

FIG. 6 shows a vehicle body structure according to a fifth embodiment. In the fifth embodiment, a plate thickness of the floor panel side portion **55A** is changed in contrast to the second embodiment shown in FIG. 3. Specifically, in the floor panel side portion **55A**, thickened portions **55e** and **55f** are formed by making the plate thickness of portions to be joined to corner portions **25g** and **25h** of the side sill inner member **25** greater than the plate thickness of the remaining portions. The corner portion **25g** is a boundary portion between the side wall **25a** and the upper wall **25b** while the corner portion **25h** is a boundary portion between the upper wall **25b** and the upper flange **25d**.

According to the fifth embodiment, the plate thickness of the portions of the floor panel side portion **55A** to be joined to the corner portions **25g** and **25h** of the side sill inner member **25** is greater than the plate thickness of portions of the floor panel side portion **55A** to be joined to a flat portion inclusive of the side wall **25a** and the upper wall **25b** of the side sill inner member **25**. As a consequence, the bent shape of each of the corner portions **25g** and **25h** is less likely to be deformed in case of receiving a lateral collision load, for example. Thus, this configuration can contribute to an improvement in rigidity.

Sixth Embodiment

FIG. 7 shows a vehicle body structure according to a sixth embodiment. In the sixth embodiment, a projection **25i** that projects toward the inner side in the vehicle width direction (the left side in FIG. 7) is formed on the upper flange **25d** of a side sill inner member **25E** in contrast to the second embodiment shown in FIG. 3. The projection **25i** is formed at a position distant upward from the upper wall **25b**. The projection **25i** may be provided as a separate member from the side sill inner member **25E** and fixed thereto by welding or the like, or may be formed integrally with the side sill inner member **25E** by press molding. The floor panel side portion **55A** is the same as that shown in FIG. 3, and the floor end wall **55Ab3** is formed between the projection **25i** and the upper wall **25b**.

The side sill inner member **25E** according to the sixth embodiment includes the projection **25i** which is smaller than the protruding portion **33** and projects from the upper flange **25d** toward the floor panel side portion **55A** at a position above the upper wall **25b**. The end in the vehicle width direction of the flange portion **55Ab** is located closer

to the protruding portion **33** than the projection **25i** is. In this case, the floor panel side portion **55A** is fixed such that the floor upper wall **55Ab2** and the floor end wall **55Ab3** are sandwiched in the up-down direction between the upper wall **25b** and the projection **25i** of the side sill inner member **25E**. As a consequence, the junction strength between the side sill inner member **25E** and the floor panel side portion **55A** is improved.

Seventh Embodiment

FIG. **8** shows a seventh embodiment. In the seventh embodiment, orientations of fiber-reinforcement materials **35** and **36** such as a resin impregnated with carbon fibers are kept constant in the floor panel side portion **55A** of the second embodiment shown in FIG. **3**, for example. Specifically, in the floor side wall **55Ab1** of the flange portion **55Ab**, the fiber-reinforcement material **35** is oriented substantially parallel to a surface of the floor side wall **55Ab1** and along the vertical direction (the vehicle body up-down direction). In the floor upper wall **55Ab2** of the flange portion **55Ab**, the fiber-reinforcement material **36** is oriented substantially parallel to a surface of the floor upper wall **55Ab2** and along the vehicle width direction. The fiber-reinforcement material **35** and the fiber-reinforcement material **36** may be lined to each other. Note that fiber-reinforcement materials on the bottom wall **55a** and the floor end wall **55Ab3** as well as the side sill outer member **27** are omitted in FIG. **8**.

As described above, each of the fiber-reinforcement materials **35** and **36** is oriented to a constant direction on a single plane and is orthogonal to the vehicle body front-rear direction in a crossing manner. In this case, when the side sill inner member **25** develops a deformation load in such a way as to be bent along the up-down direction as the vehicle body receives a lateral collision load **F1**, for example, the fiber-reinforcement materials **35** and **36** with their longitudinal directions being orthogonal to the vehicle body front-rear direction counteract this load and secure rigidity.

When the respective orientations of the respective fiber-reinforcement materials **35** and **36** are set constant, the fiber-reinforcement materials **35** and **36** may be oriented to the vehicle body front-rear direction on the floor side wall **55Ab1** and the floor upper wall **55Ab2**, respectively. In this case, when the side sill inner member **25** develops a deformation load in such a way as to be bent along the vehicle body front-rear direction as the vehicle body receives a collision load **F2** in the front-rear direction, for example, the fiber-reinforcement materials with their longitudinal directions being in line with the vehicle body front-rear direction counteract this load and secure rigidity.

Here, in the case of orienting each of the fiber-reinforcement materials in the constant direction, the direction is not limited only to the direction orthogonal to the vehicle body front-rear direction or to the vehicle body front-rear direction as mentioned above. For example, the direction may be a direction inclined from the vehicle body front-rear direction.

The resin floor panel side portion **55A** according to the seventh embodiment further includes the fiber-reinforcement materials **35** and **36** each oriented to the constant direction on the single plane. As a consequence, rigidity is secured by the fiber-reinforcement materials **35** and **36** when the side sill **15** receives the collision load, and the deformation is thus suppressed.

Eighth Embodiment

FIG. **9** shows an eighth embodiment. In the eighth embodiment, ribs **37** serving as resin members are molded

integrally with the side sill outer member **27** at a region opposed to the protruding portion **33** of the side sill inner member **25** in the structure including the floor panel side portion **55A** of the second embodiment shown in FIG. **3**, for example. The ribs **37** are in close contact with inner surfaces of the side wall **27a**, the upper wall **27b**, and the lower wall **27c** of the side sill outer member **27**, respectively. The ribs **37** have a constant plate thickness in a direction orthogonal to the sheet surface in FIG. **9**, and are provided at intervals in the direction orthogonal to the sheet surface in FIG. **9**.

The side sill inner member **25** integrally provided with the floor panel side portion **55A** and the side sill outer member **27** integrally provided with the ribs **37** are joined by welding the upper flanges **25d** and **27d** to each other and welding the lower flanges **25e** and **27e** to each other, respectively. Thus, the floor panel side portion **55A** and the side sill **15** are integrated together. Here, the resin material that forms the ribs **37** may be the same as the resin that forms the floor panel side portion **55A** or may be a different material therefrom.

The eighth embodiment includes the side sill outer member **27** joined to a different side in the vehicle width direction from the floor panel side portion **55A** of the side sill inner member **25** and configured to form the closed cross-sectional portion **29** in conjunction with the side sill inner member **25**, and further includes the ribs **37** disposed at regions of the side sill outer member **27** which are opposed to the protruding portion **33**. As a consequence, the side sill outer member **27** is reinforced by the ribs **37** and rigidity of the side sill outer member **27** is thus improved. In this case, together with the reinforcement brought about by joining the floor panel side portion **55A** to the protruding portion **33**, the higher rigidity of the side sill inner member **25** is secured especially against a lateral collision load.

Ninth Embodiment

Next, a method for manufacturing a vehicle body in a case of molding the floor panel side portion **55B** integrally with the side sill inner member **25B** shown in FIG. **4**, for instance, will be described as a ninth embodiment.

FIG. **10** shows a region around the side sill **15** on the left side in the vehicle width direction, in which the vehicle width direction is reverse to that in FIG. **1**. FIG. **11** is a cross-sectional view of a portion in the middle of molding, which corresponds to a B-B cross-sectional structure in FIG. **10** inclusive of molds. FIG. **11** illustrates a resin piece **39** in a solid state to be put in before molding in order to form the floor panel side portion **55B**. The resin piece **39** is a composite material prepared by mixing a fiber-reinforcement material such as carbon fibers with a thermoplastic resin such as polyimide. The resin piece **39** corresponds to the resin-containing material.

As shown in FIGS. **10** and **11**, a panel material **41** made of a metal as with the side sill inner member **25B**, and a reinforcement material **43** of a hat-like cross-sectional shape which is fixed by welding to a lower surface of the panel material **41** are provided on an inner side in the vehicle width direction (the right side in FIG. **11**) of the floor panel side portion **55B**. The panel material **41** and the reinforcement material **43** extend along the vehicle body front-rear direction.

A floor panel central portion **56B** is formed on the inner side in the vehicle width direction of the panel material **41** and the reinforcement material **43**. The floor panel central portion **56B** is formed from a resin-containing material as with the floor panel side portion **55B**. As shown in FIG. **10**,

a center tunnel **45** made of a metal as with the side sill inner member **25B** is formed on a further inner side in the vehicle width direction of the floor panel central portion **56B**.

The center tunnel **45** is located at the center in the vehicle width direction and extends in the vehicle body front-rear direction. Another panel material **41** and another reinforcement material **43** are also formed in bilaterally symmetrical shapes on the right side in the vehicle width direction about the center tunnel **45** as the center. The floor panel **5** provided with the floor panel side portion **55B** and the floor panel central portion **56B** has a bilaterally symmetrical shape about the center tunnel **45** as the center.

The molds include a lower mold **47**, an upper mold **49**, and a slide mold **51**. The upper mold **49** descends from a position shown in FIG. **11** toward the lower mold **47**. The slide mold **51** moves in a rightward direction from a position shown in FIG. **11** toward the lower mold **47**. The molds shown in FIG. **11** have substantially laterally symmetrical shapes about the center tunnel **45** as the center, and illustration of the right side in the vehicle width direction thereof inclusive of the center tunnel **45** is omitted.

Here, in addition to the floor panel side portion **55B** and the floor panel central portion **56B** included in the floor panel **5**, resin panel portions **11a** and **11b** that form the dash panel **11** are also integrally molded from the resin-containing material as shown in FIG. **10**. Front panel materials **53** and **57** each made of a metal are provided between the set of the resin panel portions **11a** and **11b** and the set of the floor panel side portion **55B** and the floor panel central portion **56B**. Two sides in the vehicle width direction of the front panel material **53** are joined by welding to the side sill **15** and to the set of the panel material **41** and the reinforcement material **43**, respectively. Two sides in the vehicle width direction of the front panel material **57** are joined by welding to the set of the panel material **41** and the reinforcement material **43** and to the center tunnel **45**, respectively.

As shown in FIG. **11**, the lower mold **47** includes a cutout portion **47a** at a corner portion corresponding to an outer side end in the vehicle width direction. The cutout portion **47a** includes a bottom surface **47a1** and an outer side surface **47a2**. The side sill inner member **25B** is disposed at the cutout portion **47a**. In this case, the lower wall **25c** of the side sill inner member **25B** is brought into contact with the bottom surface **47a1** and the side wall **25a** thereof is brought into contact with the outer side surface **47a2**, respectively.

The lower mold **47** is provided with a recess **47c** which is located at a position corresponding to an inner side in the vehicle width direction of the cutout portion **47a** and recessed downward from an upper end surface **47b**. The reinforcement material **43** is disposed and housed in the recess **47c**. The panel material **41** is fixed by welding to the reinforcement material **43** in advance. The reinforcement material **43** includes a bottom portion wall **43a**, right and left side portion walls **43b**, and flanges **43c** that project toward right and left sides from upper ends of the side portion walls **43b**. The panel material **41** is fixed by welding onto the flanges **43c**.

The recess **47c** includes a bottom surface **47c1** and right and left side surfaces **47c2**, and is provided with projections **47d** that project upward from upper ends of the right and left side surfaces **47c2**. Lower surfaces on the side portion wall **43b** side of the flanges **43c** come into contact with upper ends of the projections **47d** in the state where the bottom portion wall **43a** of the reinforcement material **43** is in contact with the bottom surface **47c1** of the recess **47c**. In this instance, a gap **48** is formed between a lower surface on

a tip side of each flange **43c** and the upper end surface **47b** of the lower mold **47**. The resin-containing material that forms part of the floor panel side portion **55B** and the floor panel central portion **56B** at the time of molding enters the right and left gaps **48**, respectively.

The upper mold **49** includes a lower end surface **49a** opposed to the upper end surface **47b** of the lower mold **47**, an inclined side surface **49b** that rises from a side edge at a region corresponding to an outer side in the vehicle width direction of the lower end surface **49a**, and a rim portion lower end surface **49c** that extends from an upper end of the inclined side surface **49b** toward a side corresponding to the outer side in the vehicle width direction. The inclined side surface **49b** is inclined in such a way as to become parallel to the inclined wall **25f** of the side sill inner member **25B**. Although it is not illustrated, the upper mold **49** includes a front projection and a rear projection which project downward from respective ends corresponding to two ends in the vehicle body front-rear direction. The front projection and the rear projection come into contact with the upper end surface **47b** of the lower mold **47** at the time of mold closing. Thus, a molding space is defined by the lower mold **47**, the upper mold **49**, and the right and left slide molds **51** at the time of mold closing.

Each slide mold **51** is inserted into a space surrounded by the side wall **25a**, the upper wall **25b**, the lower wall **25c**, and the inclined wall **25f** of the side sill inner member **25B**. The slide mold **51** includes wall portions **51a**, **51b**, **51c**, and **51f** that come into contact with the respective walls **25a**, **25b**, **25c**, and **25f** mentioned above.

As shown in FIG. **11**, the side sill inner member **25B** is disposed at the cutout portion **47a** of the lower mold **47** and the reinforcement material **43** integrated with the panel material **41** is disposed at the recess **47c** of the lower mold **47**. Moreover, multiple resin pieces **39** are disposed on the upper end surface **47b** of the lower mold **47** at portions to mold the floor panel side portion **55B**, the floor panel central portion **56B**, and the like with the resin.

After the metal members including the side sill inner member **25B**, the panel material **41**, the reinforcement material **43**, and the like are disposed in the lower mold **47**, the slide mold **51** is inserted and disposed inside the side sill inner member **25B** by causing the slide mold **51** to slide as shown in FIG. **12**. In this state, pressure molding is conducted by causing the upper mold **49** to descend as shown in FIG. **12**. At the time of pressure molding, the lower end surface **49a** of the upper mold **49** comes into contact with the panel material **41**, the front panel materials **53** and **57**, and the center tunnel **45**, while the rim portion lower end surface **49c** comes into contact with the upper wall **25b** of the side sill inner member **25B**. Moreover, the front projection and the rear projection, which are not illustrated, of the upper mold **49** come into contact with the upper end surface **47b** of the lower mold **47**.

Accordingly, the outer side in the vehicle width direction of the floor panel side portion **55B** is joined to and molded integrally with the side sill inner member **25B** while the inner side in the vehicle width direction thereof is joined to and molded integrally with the panel material **41** and the reinforcement material **43**. The outer side in the vehicle width direction of the floor panel central portion **56B** is joined to and molded integrally with the panel material **41** and the reinforcement material **43** while the inner side in the vehicle width direction thereof is joined to and molded integrally with the center tunnel **45**.

The ninth embodiment includes a part disposing step of disposing the side sill inner member **25B** made of a metal

11

into the molds, and a resin supplying step of supplying the resin pieces 39 into the molds. Moreover, this embodiment also includes a pressure molding step of molding the resin pieces 39 in the molds into the floor panel side portion 55B provided with the flange portion 55Bb by applying the pressure to the resin pieces 39, and joining the flange portion 55Bb to the side sill inner member 25B. When the floor panel side portion 55B is molded in the pressure molding step, the flange portion 55Bb is formed to be bent toward the upper side from the bottom wall 55a at the end in the vehicle width direction thereof.

In this case, the molding of the floor panel side portion 55B and the joining of the floor panel side portion 55B to the side sill inner member 25B, the panel material 41, and the reinforcement material 43 can be carried out at the same time. This makes it possible to simplify the manufacturing process and to achieve cost reduction. In this instance, the floor panel side portion 55B is joined in such a way as to cause the flange portion 55Bb to butt the inclined wall 25f. As a consequence, it is possible to secure a larger junction area between the floor panel side portion 55B and the side sill inner member 25B by the flange portion 55Bb, whereby adhesion is increased and the junction strength is improved.

When the flange portion 55Bb joined to the side sill inner member 25B is used as part of the side sill 15, the thickness in the vehicle width direction of the side sill 15 becomes thicker in an amount equivalent to the additional plate thickness of the flange portion 55Bb, whereby the cross-sectional shape of the side sill 15 becomes larger. Thus, it is possible to improve rigidity of the side sill 15 corresponding to a region around a junction of the side sill inner member 25B and the floor panel side portion 55B. In particular, the larger thickness in the vehicle width direction of the side sill 15 increases rigidity against a lateral collision load.

In addition, the molding of the floor panel central portion 56B and the joining of the floor panel central portion 56B to the panel material 41, the reinforcement material 43, and the center tunnel 45 can be carried out at the same time. This makes it possible to simplify the manufacturing process and to achieve cost reduction.

In the example shown in FIGS. 11 and 12, the flange portion 55Bb of the floor panel side portion 55B is joined to the inclined wall 25f of the side sill inner member 25B. Specifically, the side sill inner member 25B of this embodiment includes the protruding portion 33 that projects from the rim portion 31 toward the floor panel side portion 55B. The peak portion 25a of the protruding portion 33 to be joined to the flange portion 55Bb, which is located away from the rim portion 31 to the floor panel side portion 55B side, includes the inclined wall 25f that is inclined relative to the vertical direction. In the pressure molding step, the pressure in the up-down direction is applied to the inclined wall 25f.

In this case, when the pressure molding is carried out as shown in FIG. 12, it is possible to apply the pressure between the inclined side surface 49b of the upper mold 49 and the inclined wall portion 51f of the slide mold 51 in such a direction that presses the flange portion 55Bb against the inclined wall 25f of the side sill inner member 25B. In this way, the adhesion between the flange portion 55Bb and the side sill inner member 25B is improved. Here, in order to reliably apply the pressure, it is desirable to set an inclination angle of the inclined wall 25f equal to or above 10° relative to the vertical direction.

Tenth Embodiment

In FIG. 13 heaters 59 and 61 are attached to the upper mold 49 and the slide mold 51, respectively, in contrast to

12

FIG. 11. As for the heaters 59 and 61, heaters for heating molds, for example, are buried into the upper mold 49 and the slide mold 51. The heaters 59 and 61 are provided at positions corresponding to the junction of the flange portion 55Bb of the floor panel side portion 55B and the inclined wall 25f of the side sill inner member 25B. To be more precise, the heater 59 is disposed at a position corresponding to the inclined side surface 49b of the upper mold 49 while the heater 61 is located at a position corresponding to the wall portion 51f of the slide mold 51. At the time of pressure molding, the upper mold 49 and the slide mold 51 are heated by energizing the heaters 59 and 61.

The tenth embodiment includes a mold heating step of heating the portions of the upper mold 49 and the slide mold 51 at the positions corresponding to the junction of the side sill inner member 25B and the floor panel side portion 55B by using the heaters 59 and 61. In this case, the junction of the side sill inner member 25B and the floor panel side portion 55B is heated at the time of mold closing when the pressure molding takes place by causing the upper mold 49 to descend. Thus, fluidity of the resin at the region corresponding to the junction of the side sill inner member 25B and the floor panel side portion 55B is increased and the adhesion between the side sill inner member 25B and the floor panel side portion 55B is improved at the junction.

Here, the timing to energize the heaters 59 and 61 is set in a step preceding the pressure molding step, or as a step after the part disposing step of disposing the side sill inner member 25B, the panel material 41, and the reinforcement material 43 into the lower mold 47, for example. By heating the upper mold 49 and the slide mold 51 in advance prior to application of the pressure, the fluidity of the resin is further increased.

Eleventh Embodiment

In FIG. 14, each resin piece 39 in a solid state is preheated with a heating device 63 such as a heater instead of providing the heaters 59 and 61 of FIG. 13. The resin pieces 39 heated with the heating device 63 are supplied onto the upper end surface 47b of the lower mold 47 at positions where the resin molding takes place, such as positions to form the floor panel side portion 55B and the floor panel central portion 56B. In other words, the eleventh embodiment includes a resin heating step of heating the resin pieces 39 before being supplied into the molds. Thus, the fluidity of the resin at the region corresponding to the junction of the side sill inner member 25B and the floor panel side portion 55B is increased and the adhesion between the side sill inner member 25B and the floor panel side portion 55B is improved at the junction.

Twelfth Embodiment

In FIG. 15, a projection 25j that projects toward the inner side in the vehicle width direction is formed at an upper part of the inclined wall 25f of the side sill inner member 25B in contrast to FIG. 11. The projection 25j may be provided as a separate member from the side sill inner member 25B and fixed by welding or the like, or may be formed integrally with the side sill inner member 25B by press molding.

An amount of supply of the resin pieces 39 in the twelfth embodiment is set such that a thickness in the vehicle width direction of the flange portion 55Bb of the floor panel side portion 55B becomes substantially equal to a height of the projection 25j from the inclined wall 25f at a position to mold the flange portion 55Bb.

According to the twelfth embodiment, the side sill inner member **25B** includes the projection **25j** being located at the position corresponding to a tip of the flange portion **55Bb** and projecting to the floor panel side portion **55B** side. In the resin supplying step, the resin pieces **39** in such an amount that the thickness in the vehicle width direction of the flange portion **55Bb** becomes equal to a projecting height of the projection **25j** to the floor panel side portion **55B** side is supplied into the molds. In this case, provision of the projection **25j** makes it possible to inhibit the resin from flowing out of a resin molding space at the time of pressure molding. By setting the thickness of the flange portion **55Bb** equal to the projecting height of the projection **25j**, it is possible to efficiently apply a force to bring the resin into close contact with the side sill inner member **25B** at the time of pressure molding.

Thirteenth Embodiment

As shown in FIG. **16**, in a thirteenth embodiment, the floor panel side portion **55A** is molded integrally with the side sill inner member **25** as with the embodiment shown in FIG. **9**, while the ribs **37** are molded integrally with the side sill outer member **27** as with the embodiment shown in FIG. **9**. Thereafter, the side sill inner member **25** and the side sill outer member **27** are integrated together by joining the upper flanges **25d** and **27d** to each other and the lower flanges **25e** and **27e** to each other by welding, respectively. In this case, the floor panel side portion **55A** is molded integrally with the side sill inner member **25** before the side sill inner member **25** is joined by welding to the side sill outer member **27**.

The thirteenth embodiment includes a side sill part joining step of joining the side sill outer member **27** made of a metal to the side sill inner member **25** on a different side in the vehicle width direction from the floor panel side portion **55A**. The closed cross-sectional portion **29** is formed between the side sill inner member **25** and the side sill outer member **27**. Thus, the side sill **15** secures rigidity against a lateral collision load in particular. In this instance, the rigidity is further improved since the ribs **37** are molded integrally with the side sill outer member **27**.

In the side sill part joining step of the thirteenth embodiment, the side sill inner member **25** in the state of being joined to the floor panel side portion **55A** is joined by welding to the side sill outer member **27** joined to the ribs **37**. In this case, it is possible to conduct molding work accurately and efficiently by molding the floor panel side portion **55A** integrally with the side sill inner member **25** before the side sill inner member **25** is joined by welding to the side sill outer member **27**. When the floor panel side portion **55A** is molded integrally with the side sill inner member **25** in the state where the side sill outer member **27** is joined by welding thereto, it is necessary to dispose the side sill outer member **27** integrated with the side sill inner member **25** in the mold. This configuration leads to an increase in size of each mold and causes a deterioration in precision of a molded product.

While the embodiments of the present invention have been discussed above, these embodiments are mere examples described in order to facilitate the understanding of the present invention, and the present invention is not limited only to the embodiments. The technical scope of the present invention is not limited only to the specific technical matters disclosed in the above-described embodiments, and various modifications, alterations, alternative techniques, and the like which are easily derivable therefrom are also encompassed by the present invention.

For example, in the above-described embodiments, the resin pieces **39** in the solid state are first supplied into the molds and are then subjected to pressure molding in the case of molding the floor panel side portion **55** integrally with the side sill inner member **25**. Instead, a molten resin may be supplied into the molds by injection and then subjected to pressure molding.

REFERENCE SIGNS LIST

25, 25B, 25E side sill inner member (side sill part)
25a side wall (peak portion) of side sill inner member
25a1 dent (indented structure)
25b upper wall (upper surface portion, intermediate portion) of side sill inner member
25c lower wall (lower surface portion, intermediate portion) of side sill inner member
25i, 25j projection
27 side sill outer member (second side sill part)
29 closed cross-sectional portion
31 rim portion of side sill inner member
33 protruding portion of side sill inner member
35, 36 fiber-reinforcement material
37 rib (resin member)
39 resin piece
55, 55A, 55B floor panel side portion (floor part)
55b, 55Ab, 55Bb, flange portion

The invention claimed is:

1. A vehicle body structure comprising:

a resin floor part including a bottom wall and a flange portion bent toward an upper side or a lower side at an end in a vehicle width direction of the bottom wall; and a metal side sill part joined to the resin floor part at the flange portion, wherein

the side sill part includes a rim portion, a peak portion, and an intermediate portion linking the rim portion to the peak portion,

the peak portion and the intermediate portion form a protruding portion projecting from the rim portion toward the floor part,

the flange portion of the resin floor part is joined to the peak portion of the protruding portion,

the peak portion to be joined to the flange portion includes an inclined wall that is inclined relative to a vertical direction, and

the flange portion and a bent portion formed between the bottom wall and the flange portion are in close contacted directly with the inclined wall and joined to the inclined wall by an integral molding of the floor part and the side sill part.

2. The vehicle body structure according to claim **1**, wherein

the intermediate portion includes an upper surface portion located at an upper part of a vehicle body and a lower surface portion located at a lower part of the vehicle body, and

the flange portion is formed to be bent toward the upper side and joined to the upper surface portion.

3. The vehicle body structure according to claim **2**, wherein

the side sill part includes a projection projecting from the rim portion toward the floor part side at a position above the upper surface portion, the projection being smaller than the protruding portion, and

an end in the vehicle width direction of the flange portion is located closer to the protruding portion than the projection is.

15

- 4. The vehicle body structure according to claim 1, wherein
an indented structure being smaller than the protruding portion is formed on a surface of the side sill part to be joined to the floor part.
- 5. The vehicle body structure according to claim 1, wherein
a plate thickness of a portion of the floor part to be joined to a corner portion of the side sill part is greater than a plate thickness of a portion of the floor part to be joined to a flat portion of the side sill part.
- 6. The vehicle body structure according to claim 1, wherein
the resin floor part contains fibers oriented to a constant direction.
- 7. The vehicle body structure according to claim 1, further comprising:
a second side sill part joined to a different side in the vehicle width direction from the floor part of the side sill part, and configured to form a closed cross-sectional portion in conjunction with the protruding portion of the side sill part; and
a resin member disposed at a region of the second side sill part opposed to the protruding portion.

16

- 8. The vehicle body structure according to claim 1, wherein
an upper end of the inclined wall and an end on the floor part side of the intermediate portion are bent at a side sill bent portion, and
an upper end of the flange portion is located at the side sill bent portion.
- 9. The vehicle body structure according to claim 1, wherein
the bent portion and the flange portion of the floor part are joined to the entire inclined wall in an inclined direction.
- 10. The vehicle body structure according to claim 1, wherein
the bent portion and the flange portion are in close contacted directly with the inclined wall and joined to the inclined wall in a state that a pressure applied during the integral molding is applied to the inclined wall.
- 11. The vehicle body structure according to claim 1, wherein
a recess is formed in the inclined wall, and a resin of the integral molding enters the recess.

* * * * *