



INTERNATIONAL APPLICATION PUBLISHED UNDER THE PATENT COOPERATION TREATY (PCT)

(51) International Patent Classification ⁵ : E05B 15/00	A1	(11) International Publication Number: WO 97/21893 (43) International Publication Date: 19 June 1997 (19.06.97)
<p>(21) International Application Number: PCT/US95/16666</p> <p>(22) International Filing Date: 12 December 1995 (12.12.95)</p> <p>(71)(72) Applicants and Inventors: SMITH, Jerry, R. [US/US]; 5690 West Rowland Avenue, Littleton, CO 80123 (US). HICK, John, N. [US/US]; 1886 S. Humboldt Street, Denver, CO 80210 (US).</p> <p>(74) Agents: MARTIN, Timothy, J. et al.; Timothy J. Martin, P.C., Suite 200, 9250 W. 5th Avenue, Lakewood, CO 80226 (US).</p>	<p>(81) Designated States: AU, CA, JP, European patent (AT, BE, CH, DE, DK, ES, FR, GB, GR, IE, IT, LU, MC, NL, PT, SE).</p> <p>Published <i>With international search report.</i> <i>With amended claims.</i></p>	

(54) Title: DOOR LATCH ACTUATOR

(57) Abstract

A door latch actuator (10, 210, 510) is to be engaged by a latch bolt (44) of latch bolt assembly (38) on a door (40) mounted for movement between a first door position and a second door position. Broadly, the door latch actuator (10, 210, 510) comprises an actuator element (16, 116, 216, 512, 514) and a driver (18, 312, 316). The actuator element is disposed in proximity to the distal end of the latch bolt (44) when the door (40) is at the first door position in the secured condition and moves between a first actuator position and a second actuator position. In the first actuator position, the actuator element (16, 116, 216, 512, 514) allows the distal end of the latch bolt (44) to secure the door (44). When moved into the second actuator position, the latch bolt (44) is displaced from the extended state to the retracted state causing the door (44) to be unsecured.

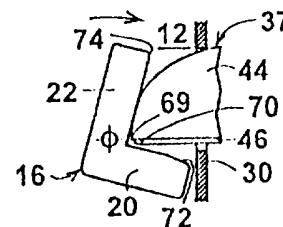

FOR THE PURPOSES OF INFORMATION ONLY

Codes used to identify States party to the PCT on the front pages of pamphlets publishing international applications under the PCT.

AN	Armenia	GB	United Kingdom	MW	Malawi
AT	Austria	GE	Georgia	MX	Mexico
AU	Australia	GN	Guinea	NE	Niger
BB	Barbados	GR	Greece	NL	Netherlands
BE	Belgium	HU	Hungary	NO	Norway
BF	Burkina Faso	IE	Ireland	NZ	New Zealand
BG	Bulgaria	IT	Italy	PL	Poland
BJ	Benin	JP	Japan	PT	Portugal
BR	Brazil	KE	Kenya	RO	Romania
BY	Belarus	KG	Kyrgystan	RU	Russian Federation
CA	Canada	KP	Democratic People's Republic of Korea	SD	Sudan
CF	Central African Republic	KR	Republic of Korea	SE	Sweden
CG	Congo	KZ	Kazakhstan	SG	Singapore
CH	Switzerland	LI	Liechtenstein	SI	Slovenia
CI	Côte d'Ivoire	LK	Sri Lanka	SK	Slovakia
CM	Cameroon	LR	Liberia	SN	Senegal
CN	China	LT	Lithuania	SZ	Swaziland
CS	Czechoslovakia	LU	Luxembourg	TD	Chad
CZ	Czech Republic	LV	Latvia	TG	Togo
DE	Germany	MC	Monaco	TJ	Tajikistan
DK	Denmark	MD	Republic of Moldova	TT	Trinidad and Tobago
EE	Estonia	MG	Madagascar	UA	Ukraine
ES	Spain	ML	Mali	UG	Uganda
FI	Finland	MN	Mongolia	US	United States of America
FR	France	MR	Mauritania	UZ	Uzbekistan
GA	Gabon			VN	Viet Nam

DOOR LATCH ACTUATOR
FIELD OF THE INVENTION

This invention generally relates to a door latch actuator which works in cooperation with a standard latch bolt assembly of a door to control access into a building or a restricted area.

BACKGROUND OF THE INVENTION

Providing security for a door has been a concern over centuries. Modern door locks are used in conjunction with a conventional latch bolt assembly which is installed on a standard door. The latch bolt assembly includes a spring latch bolt and often includes a dead latch bolt that enables and disables movement of the spring latch bolt. Typically, a strike plate is used to retain the dead latch bolt in its disable state to prevent retraction of the spring latch bolt unless a computerized security system is employed.

In a computerized system, an electronic strike is activated when an appropriate access code is detected. In general, this electronic strike includes a single-lobed cam that pivots between a door lock position and a door release position. In its door lock position, the cam is positioned to simultaneously capture the spring latch bolt and the dead latch bolt with the spring latch bolt projecting into its extended state and with the dead latch bolt retained in its disable state. In the door lock position, a pin from an electrically-powered solenoid extends into a recess in the cam to prevent movement of the cam from pivoting out of its door lock position. When the correct access code is detected, the pin from the solenoid withdraws from the recess in the cam so that the cam is free to pivot away from the latch as the door is pulled open. After the latch bolt assembly clears the cam, it springs back into its original position and, after a few seconds, the pin of the solenoid once again is extended into the recess of the cam to retain the door in its closed position.

SUMMARY OF THE PRESENT INVENTION

It is an object of the present invention to provide a new and useful door latch actuator that is simple to manufacture and easy to install and that provides a higher degree of

security, compared to those of the prior art, by employing a strike plate which is commonly used on doorjamb.

It is yet another object of the present invention to provide a door latch actuator that is generally insensitive to back pressure applied to the door so that the door can be opened even if back pressure is being applied to the door.

Another object of the present invention is to provide a door latch actuator that can be easily and quickly retro-fitted onto existing non-secured door systems to provide security therefor without making major modifications to the doorjamb.

Yet another object of the present invention is to provide a door latch actuator that interacts with the standard dead latch bolt to depress the dead latch bolt until actuation so that the security feature afforded by the dead latch bolt is retained.

In general, the door latch actuator of the present invention is adapted for use in association with a conventional latch bolt assembly on a conventional door which is pivotally mounted on a door frame for movement between a first door position and a second door position. The latch bolt assembly includes a latch bolt having a distal end which slideably moves between an extended state and a retracted state and is operative in the extended state to engage a bolt receiver to retain the door at the first door position in a secured condition.

In its broadest form, the door latch actuator comprises an actuator element which is disposed in proximity to the distal end of the latch bolt when the door is at the first door position in the secured condition and a driver, such as a motor or solenoid, which is associated with the actuator element. The actuator element moves between a first actuator position and a second actuator position. In the first actuator position, the actuator element allows the distal end of the latch bolt to engage the bolt receiver in the extended state. In the second actuator position, the actuator element mechanically displaces the latch bolt from the extended state to retracted state causing the door to be in an unsecured

condition at the first door position so that the door can then be moved from the first door position to the second door position. The driver operates to move the actuator element between the first and second actuator positions. The actuator member preferably is a cam, and the driver acts to move the cam between the first and second actuator positions. The driver operates to provide a reversible driving force to the cam and acts to reciprocally pivot the cam between the first and second actuator positions.

It is also preferred that the door latch actuator include a controller device operative to reversibly activate the driver so that the cam is caused to pivot between the first and second actuator positions. Also, timer circuitry may be included with the controller to operate after the cam pivots from the first actuator position to the second actuator position to cause the cam to return the first actuator position upon expiration of a selected period of time.

Where the conventional latch bolt assembly in the door includes a spring latch bolt and dead latch bolt, an alternative door latch actuator can be employed according to the present invention. Generally, this door latch actuator comprises an actuator element disposed in proximity to distal ends of the spring latch bolt and the dead latch bolt and a driver which is associated with the actuator element. The actuator element moves between a first actuator position and a second actuator position. In the first actuator position, the actuator element is operative to retain the dead latch bolt in the disable state while allowing the spring latch bolt to extend into the latch bolt receiving cavity in the extended state to retain the door at the first door position in a secured condition. The actuator element, operative upon movement from the first actuator position to the second actuator position, first releases the dead latch bolt so that it moves into the enable state, the actuator element next attacks the distal end of the spring latch bolt to move the spring latch bolt from the extended state to the retracted state. Now, the door can be moved from the first door

position to the second door position. The driver operates to move the actuator element between the first and second actuator positions by causing the actuator element to pivot about an axis.

In any event, the door latch actuator may be supported on a strike plate which is adapted to connect to the driver and to releasably attach to the doorjamb and over the latch bolt receiving cavity. The strike plate has a port adapted for the spring latch bolt and the dead latch bolt to extend therethrough and into the latch bolt receiving cavity in the doorjamb. This allows the door latch actuator to be retrofitted into existing doorjamb.

BRIEF DESCRIPTION OF THE DRAWINGS

Figure 1 is a side elevational view of a door in a secured condition at a first door position within a doorjamb and having a portion of the doorjamb broken away to show a door latch actuator according to a first preferred exemplary embodiment of the present invention and operable with a conventional latch bolt assembly of a door and a conventional electronic trigger element;

Figure 2 is an exploded perspective view of the door latch actuator shown in Figure 1;

Figure 3 is a perspective view of the distal ends of a spring latch bolt and a dead latch bolt which extend from a conventional latch bolt assembly installed in a conventional door;

Figure 4 is an enlarged side elevational view of the door latch actuator of Figures 1 and 2 and operable with the conventional latch bolt assembly shown in Figure 3;

Figure 5(a) is a top plan view taken along lines 5-5 in Figure 4 of an actuator element of the present invention disposed in proximity to the conventional latch bolt assembly wherein a spring latch bolt extends into a latch bolt receiving cavity in the extended state and a dead latch bolt is retained in the disable state within the latch bolt receiving cavity;

Figure 5(b) is a top plan view taken along line 5- 5 in

Figure 4 of the actuator element of the present invention disposed in proximity to the conventional latch bolt assembly wherein the spring latch bolt extends into the latch bolt receiving cavity in the extended state and the dead latch bolt is released to the enable state;

Figure 5(c) is a top plan view taken along line 5-5 in Figure 4 of the actuator element of the present invention disposed in proximity to the conventional latch bolt assembly wherein the spring latch bolt is retained in the retracted state;

Figure 6 is a perspective view of the distal end of a spring latch bolt extending from a conventional latch bolt assembly but where no dead latch bolt is employed;

Figure 7(a) is a top plan view of the actuator element disposed in proximity to the conventional latch bolt assembly of Figure 6 wherein a spring latch bolt extends into a latch bolt receiving cavity in the extended state;

Figure 7(b) is a top plan view of the actuator element disposed in proximity to the conventional latch bolt assembly of Figure 6 wherein the spring latch bolt is retained within the latch bolt receiving cavity in the retracted state;

Figure 8 is a perspective view of a second alternative exemplary embodiment of a door latch actuator shown in Figure 2;

Figure 9(a) is a top plan view of an actuator element of Figure 8 disposed in proximity to the conventional latch bolt assembly wherein the spring latch bolt extends into the latch bolt receiving cavity in the extended state and the dead latch bolt is retained in the retained state within the latch bolt receiving cavity by a sliding link;

Figure 9(b) is a top planar view of the actuator element of Figure 8 disposed in proximity to the conventional latch bolt assembly wherein the sliding link slides along a vertical surface to first allow the dead latch bolt to move to the enable state and an actuator cam portion attacks the spring latch bolt extending into the latch bolt receiving cavity;

Figure 9(c) is a top plan view of the actuator element of

Figure 8 disposed in proximity to the conventional latch bolt assembly wherein the actuator cam portion retains the spring latch bolt in the retracted state within the latch bolt receiving cavity;

Figure 10 is a top plan view of a third alternative exemplary embodiment of the door latch actuator of Figure 2 which includes a pair of solenoids;

Figure 11 is a top plan view of a fourth alternative exemplary embodiment of the door latch actuator of Figure 2 which includes an actuator cam portion and a solenoid; and

Figure 12 is a top plan view of a fifth alternative exemplary embodiment of the door latch actuator of Figure 2 which includes a pair of actuator cam elements.

DESCRIPTION OF THE EXEMPLARY EMBODIMENTS

A door latch actuator of the present invention is adapted to be installed into a latch bolt receiving cavity formed in a doorjamb so that it can operate with a conventional door latch assembly of a common door. Typically, the door latch assembly includes a spring latch bolt and a dead latch bolt. Generally, for interior doors, the door latch assembly might include only the spring latch bolt. The door latch actuator of the present invention operates with either type of door latch assembly and, in its broadest form, includes an actuator element and a driver.

With reference to Figures 1 through 5, a first preferred exemplary embodiment of a door latch actuator 10 of the present invention and its operation are shown. In Figure 1, a door latch actuator 10 is shown mounted in a latch bolt receiving cavity 12 in a doorjamb 14. As best shown in Figure 2, the door latch actuator 10 comprises an actuator element 16 and a driver 18. Here, actuator element 16 includes a first actuator cam portion 20 and a second actuator cam portion 22 which is integrally formed with one another in an L-shaped configuration. The driver 18 includes an electric motor 24 and a gear assembly 26 which is operably connected to and between the electric motor 24 and the actuator element by a shaft (not shown) of the electric motor 24 and acts to drive

the actuator element 16. It is preferable that the door latch actuator 10 be operatively mounted to and supported by a strike plate 30. Accordingly, a support bracket 32 and a support element 34 are attached to the strike plate 30. A support bracket fastener 36 cooperates with the support bracket 32 in order to secure the driver 18 onto the strike plate 30. A suitable electronic controller 28 is provided to control operation of motor 24.

The door latch actuator 10 is mounted in a latch bolt receiving cavity in a doorjamb and works in conjunction with a conventional latch bolt assembly 38 installed on a standard door 40 as shown in Figures 1, 3 and 4. The door 40 is pivotally mounted in a door frame 42 (Figure 1) so that the door can move between a first door position and a second door position. As best shown in Figure 3, the latch bolt assembly 38 includes a spring latch bolt 44 and a dead latch bolt 46. Both the spring latch bolt 44 and the dead latch bolt 46 have distal ends respectively which are spring biased to extend into the latch bolt receiving cavity 12 in the doorjamb 14 when the door 40 is in the first door position as shown in Figures 1 and 4. As one of ordinary skill in the art would appreciate, the spring latch bolt 44 is slideably movable between an extended state and a retracted state and the dead latch bolt 46 is slideably movable between an enable state and a disable state. In the enable state, the dead latch bolt 46 permits the spring latch bolt 44 to move from the extended state to the retracted state. In the disable state, the dead latch bolt 46 prohibits the spring latch bolt 44 from moving from the extended state to the retracted state. As shown in Figure 3, the spring latch bolt 44 is depicted in the extended state while the dead latch bolt 46 is depicted in its disable state. The dead latch bolt 46, shown in phantom in Figure 3, is depicted in its enable state.

To comprehend the assembly of the door latch actuator 10, reference is made to Figures 2 and 4. The strike plate 30 is adapted to connect to the driver 18. An elliptical-shaped structure 48 is rigidly attached between the electric motor 24

and the gear assembly 26. The structure 48 is received by a U-shaped slot 50 formed in the support bracket 32 attached to the strike plate 30 for a nestled fit. The support bracket fastener 36 captures the remaining portion of the elliptically-shaped structure 48 while receiving a pair of prong portions 52 and 54 of the support bracket 32 to secure the driver 18 to the strike plate 30. Although one of ordinary skill in the art would appreciate that there are many mechanical methods to fasten the driver 18 to the strike plate 30, this particular mechanical method not only secures the driver 18 to the strike plate 30 but also it prevents the driver from counter-rotating within the support bracket 32 and the support bracket fastener 36 when the driver 18 is actuated.

Shown in Figure 2, the actuator element 16 is disposed to pivot about an axis "A". A first trunnion pin 54 is concentrically positioned along axis "A" and is operably connected to the actuator element 16. Trunnion pin 54 has gear teeth and is received and driven by gear assembly 26 so that the driver 18 causes the actuator element 16 to pivot about axis "A". A second trunnion pin 56 is coaxially aligned along axis "A" and projects from the other end of actuator element 16. One of ordinary skill in the art would understand other commonly-known methods to operably connect the actuator element 16 to the driver 18.

The support element 34 is adapted to attach to the strike plate 30 by either applying an adhesive thereto or using a mechanical means such as by employing screws, rivets or other commonly known fastener means. The support element 34 is also adapted to pivotally receive the actuator element 16. The second trunnion pin 56 projecting from actuator element 16 is received by a pin-receiving hole 58 in the support element 34. The support element 34 not only helps to secure the driver 18 and the actuator member 16 to the strike plate 30 but also acts as a guide when the actuator element 16 pivots between the first and second actuator positions. For purposes of the preferred exemplary embodiment only, the support element 34

includes a stop portion 60 which is adapted to restrict movement of the actuator element 16 between the first and second actuator positions while the actuator element 16 pivots therebetween.

The strike plate 30 has a port 62 which is adapted so that the spring latch bolt 44 and the dead latch bolt 46 may extend therethrough and into the latch bolt receiving cavity 12 in the doorjamb 14. Holes 64 and 66 are formed into the strike plate 30. As shown in Figure 4, wood screws 68 are driven through holes 64 and 66 to releasably attach the strike plate 30 to the doorjamb 14 and over the latch bolt receiving cavity 12. Strike plate 30 with its port 62 acts with latch bolt receiving cavity 12 to provide a bolt receiver that receives the spring latch bolt 44. Alternatively, the bolt receiver could be provided solely by the actuator element 16.

When the door latch actuator 10 is mounted in the latch bolt receiving cavity 12 in the doorjamb 14, the actuator element 16 is disposed in proximity to a distal end 69 of the spring latch bolt 44 and a distal end 70 of the dead latch bolt 46 as depicted in Figure 5(a). The actuator element 16 is movable between a first actuator position as shown in Figure 5(a) and a second actuator position as shown in Figure 5(c) through an intermediate position shown in Figure 5(b). When in the first position (Figure 5(a)), the actuator element 16 is operative to retain the dead latch bolt 46 in the disable state while allowing the spring latch bolt 44 to extend into the latch bolt receiving cavity 12 in the extended state, thus retaining the door 40 at the first door position in a secured condition. Upon movement from the first actuator position to the second actuator position, the actuator element 16 is operative to first allow the dead latch bolt 46 to move into the enable state (Figure 5(b)) so the actuator element 16 can next attack the distal end 69 of the spring latch bolt 44 to move it from the extended state to the retracted state (Figure 5(c)). When the spring latch bolt 44 is in its retracted state, the door 40 is caused to be in an unsecured condition at the first door position so that the door 40 can

now be moved from the first door position to the second door position. It should be appreciated that it is within the scope of this invention that the first position may be where the door is closed, or, alternatively where the door is open depending upon whether it is desired to receive the door in a closed or open position. The driver 18 which is associated with the actuator element 16 is, in any event, operative to move the actuator element 16 between the first and second actuator positions as shown in Figures 5(a) and 5(c), respectively.

The actuator element 16 includes the first actuator cam portion 20 and the second actuator cam portion 22 which is connected to the first actuator cam portion 20. As shown in Figures 5(a), the first actuator cam portion 20 has a first cam surface 72 which is operative to contact a distal end 70 of the dead latch bolt 46 when the actuator element 16 is in the first actuator position. The second actuator cam portion 22 has a second cam surface 74 which is operative to contact the distal end 68 of the spring latch bolt 44 when the actuator element 16 is in the second actuator position.

It is preferred that the door latch actuator 10 include the controller device 28 which is shown in Figures 1, 2 and 4. The controller device 28 is a standard electronic controller known in the art and is operative to reversibly activate the driver 18 so that the actuator element 16 reciprocates between the first and second actuator positions as shown by viewing Figures 5(a), 5(b) and 5(c) in sequence. It is also preferred that the controller device 28 includes timer circuitry which would be operative after the actuator element 16 pivots from the first actuator position to the second actuator position to cause the actuator element 16 to return to the first actuator position upon expiration of a selected period of time.

Another type of conventional latch bolt assembly 138 installed onto a conventional door 140 is shown in Figure 6. The latch bolt assembly 138 includes a latch bolt 144 having a distal end 168 which slideably moves between an extended state as shown in Figures 6 and 7(a) and a retracted state as

shown in Figure 7(b). The latch bolt 144 is operative in the extended state to engage a bolt receiver 130 to retain the door 140 in a secured condition at the first door position. A first alternative exemplary embodiment of a door latch actuator 110 is adapted for use in association with the bolt receiver 130 which is to be engaged by the latch bolt 144 of the latch bolt assembly 138 on the door 140 shown in Figure 6. The first alternative exemplary embodiment of the door latch actuator 110 includes an actuator element 116 and a driver. Since the structure of the driver and its operation were disclosed in detail hereinabove, it is deemed that no further explanation of the driver is necessary for the purpose of describing the alternative embodiments.

The actuator element 116 is disposed in proximity to the distal end 168 of the latch bolt 144 when the door is at the first door position in the secured condition. The actuator element 116 is movable between a first actuator position as shown in Figure 7(a) and a second actuator position as shown in Figure 7(b). In the first actuator position (Figure 7(a)), the actuator element 116 allows the distal end 168 of the latch bolt 144 to engage the bolt receiver 130 in the extended state. In the second actuator position (Figure 7(b)), the actuator element 116 displaces the latch bolt 144 from the extended state to the retracted state when the latch bolt 144 is in its retracted state, the door 40 is caused to be in an unsecured condition at the first door position so that now the door 40 can be moved from the first door position to the second door position. The actuator member 116 includes a cam 120. The driver acts to move the cam 120 between the first and second actuator positions. The cam 120 provides a first cam surface 172 which is operative to contact the distal end 168 of the latch bolt 144 to move the latch bolt 144 from the extend state to the retracted state when the driver moves the cam 120 between the first and second actuator positions.

A second alternative exemplary embodiment of a door latch actuator 210 is shown in Figure 8. This door latch actuator 210 is particularly adapted for use in association with the

latch bolt assembly 38 which includes both a spring latch bolt 44 and a dead latch bolt 46 as shown in Figure 3. Again, because the driver has been discussed in detail hereinabove, no further discussion of it is deemed necessary.

An actuator element 216 includes an actuator cam portion 220 which is pivotally connected to a sliding link 222. A strike plate 230 includes a pair of support prongs 232 and 234 and a link plate 236. The support prongs 232 and 234 are adapted to pivotally receive the actuator cam portion 220. The link plate 236 is adapted to provide a vertical surface 238 upon which the sliding link 222 can slide as shown sequentially in Figures 9(a), 9(b) and 9(c). With reference to Figure 8, a spring 240 is adapted to the actuator cam portion 220 and the sliding link 222 so that the sliding link 222 remains biased against the vertical surface 238.

Operation of the second alternative exemplary embodiment of the door latch actuator 210 is shown in sequence in Figures 9(a), 9(b) and 9(c). In Figure 9(a), the spring latch bolt 44 of the conventional latch bolt assembly 38 extends through the strike plate 230 while the sliding link 232 retains the dead latch bolt 46 in its disable state. In Figure 9(b), the sliding link 222 slides along the vertical surface 238 so that the sliding link 222 first allows the dead latch bolt 46 to move from the disable state to the enable state. Once the dead latch bolt 46 is disposed in its enable state, the actuator cam portion 220 can engage the spring latch bolt 44. In Figure 9(b), the actuator cam portion 220 attacks the distal end of the spring latch bolt 44 to move it from its extended state to its retracted state as shown in Figure 9(c). Now, the door is caused to be in an unsecured condition at the first door position so that it can be moved from the first door position to the second door position can be advanced away from an unsecured position.

A third alternative exemplary embodiment of a door latch actuator 310 is shown in Figure 10. The door latch actuator 310 includes first solenoid 312 with a first plunger 314 and a second solenoid 316 with a second plunger 318. In a first

actuator position as shown in Figure 10, the second plunger 318 retains the dead latch bolt 46 in its disable state. When the second solenoid 316 withdraws the second plunger 318, the dead latch bolt 46 moves to its enable state. Now, the first solenoid 312 advances the first plunger 314 to move the spring latch bolt 44 from its extended state to its retracted state.

A suitable control circuit would be employed to control actuation of the solenoids with correct timing.

A fourth alternative exemplary embodiment of a door latch actuator 410 is shown in Figure 11. The door latch actuator 410 includes an actuator piece 416 having an actuator cam portion 420 which moves between a first actuator position and a second actuator position by a driver which has been described in detail hereinabove. The door latch actuator 410 includes a solenoid 412 having a plunger 414. One of ordinary skill in the art would appreciate the operation of this fourth alternative exemplary embodiment of the door latch actuator 410 in that it is a combination of an actuator cam portion and a solenoid. Timed operation of the cam and solenoid would again be afforded by a suitable control circuit.

A fifth alternative exemplary embodiment of a door latch actuator 510 is shown in Figure 12. A pair of actuator cam elements 512 and 514 move between a first actuator position and a second actuator position by a driver or a pair of drivers which has been described hereinabove. Timing of the movement of the pair of actuator cam elements 512 and 514 of the fifth exemplary embodiment of the present invention is again critical. To move from the first actuator position to the second portion, actuator cam element 514 must first reciprocate to allow the dead latch bolt 436 to move from its disable state to its enable state before actuator cam element 512 reciprocates to move the spring latch bolt 544 from its extended state to its retracted state, just like the other embodiments of the present invention. However, to move from the second actuator position to the first actuator position, actuator cam element 514 must reciprocate first to its original location in the actual position before actuator cam

element 512 can return to its original location in the first actuator position. Again, one of ordinary skill in the art would appreciate the operation of this fifth alternative exemplary embodiment of a door latch actuator is that it employs two separate cam elements.

It is intended that the door latch actuator of the present invention be used with a conventional trigger element 76 shown in Figure 1. Note that controller 28 can be located anywhere between the trigger element 76 and the driver 18. One type of trigger element is a computerized card reader whereby, upon insertion of a card having a magnetic strip, the card reader determines if the card is valid. Upon validation, the card reader sends an electric signal to the door latch actuator so that the door can be opened. Another type of triggering element would be a computer device having an alpha-numeric key pad. Upon inputting the appropriate access code, this triggering element would send an electric signal to the latch actuator so that the door could be opened.

One of ordinary skill in the art would appreciate that the door latch actuator of the present invention is simple to manufacture and easy to install. Further, the door latch actuator of the present invention is generally insensitive to back pressure applied to the door. This is because any back pressure would be absorbed by the strike plate rather than upon the working components of the door latch actuator. Additionally, the door latch actuator provides a higher degree of security compared to those in the prior art by employing a strike plate. The strike plate not only protects the operating components of the door latch actuator but also prevents access thereto. Now, the door latch actuator cannot be directly forced open by a lever, a crowbar or the like. The door latch actuator device of the present invention also easily retro-fits onto existing non-secured doors to provide security therefor, without making major modifications to the doorjamb.

Accordingly, the present invention has been described with some degree of particularity directed to the preferred

embodiment of the present invention. It should be appreciated, though, that the present invention is defined by the following claims construed in light of the prior art so that modifications or changes may be made to the preferred embodiment of the present invention without departing from the inventive concepts contained herein.

I claim:

1. A door latch actuator adapted for use in association with a bolt receiver which is to be engaged by a latch bolt of a latch bolt assembly on a door that is mounted for movement between a first door position and a second door position, wherein said latch bolt has a distal end which slideably moves between an extended state and a retracted state and is operative in the extended state to engage the bolt receiver to retain the door at the first door position in a secured condition, said door latch actuator comprising:

(a) an actuator element disposed in proximity to the distal end of the latch bolt when the door is at the first door position in the secured condition, said actuator element movable between a first actuator position wherein said actuator element allows the distal end of the latch bolt to engage the bolt receiver in the extended state and a second actuator position wherein said actuator element displaces said latch bolt from the extended state to the retracted state causing the door to be in an unsecured condition at the first door position so that the door can be moved from the first door position to the second door position; and

(b) a driver associated with said actuator element and operative to move said actuator element between the first and second actuator positions.

2. A door latch actuator according to claim 1 wherein said actuator member includes a cam and wherein said driver acts to move said cam between the first and second actuator positions, said cam providing a first cam surface operative to contact the distal end of the latch bolt to move said latch bolt from the extended state to the retracted state when said driver moves the cam between the first and second actuator positions.

3. A door latch actuator according to claim 2 wherein said driver is operative to provide a reversible driving force and acts to reciprocally pivot said cam between the first and second actuator positions.

4. A door latch actuator according to claim 3 wherein

said driver includes an electric motor and a gear assembly operably connected to and between said electric motor and said cam.

5. A door latch actuator according to claim 3 including a controller device operative to reversibly activate said driver whereby said cam is caused to pivot between the first and second actuator positions.

6. A door latch actuator according to claim 5 wherein said controller device includes timer circuitry operative after said cam moves from the first actuator position to the second actuator position to cause said cam to return to the first actuator position upon expiration of a selected period of time.

7. A door latch actuator mounted in a latch bolt receiving cavity in a doorjamb and operative with a latch bolt assembly on a door that is pivotally mounted in a door frame for movement between a first door position and a second door position wherein the latch bolt assembly includes a spring latch bolt and a dead latch bolt which have distal ends respectively being spring biased to extend into the latch bolt receiving cavity when the door is in the first door position, said spring latch bolt being slideably movable between an extended state and a retracted state and said dead latch bolt being slideably movable between an enable state which permits the spring latch bolt to move from the extended state to the retracted state and a disable state which prohibits the spring latch bolt from moving from the extended state to the retracted state, said door latch actuator comprising:

(a) an actuator element disposed in proximity to the distal ends of both said spring latch bolt and said door latch bolt when the door is in the first position and movable between a first and second actuator position, said actuator element when in a first actuator position operative to retain said dead latch bolt in the disable state while allowing said spring latch bolt to extend into the latch bolt receiving cavity in the extended state thereby to retain the door at the first door position in a secured condition, said actuator

element operative upon movement from the first actuator position to the second actuator position to first allow said dead latch bolt to move into the enable state and then attack the distal end of said spring latch bolt to move said spring latch bolt from the extended state to the retracted state thereby causing the door to be in an unsecured condition at the first door position so that the door can be moved from the first door position to the second door position; and

(b) a driver associated with said actuator element and operative to move said actuator element between said first and second actuator positions.

8. A door latch actuator according to claim 7 wherein said actuator element includes a first actuator cam portion and a second actuator cam portion connected to said first actuator cam portion, said first actuator cam portion having a first cam surface operative to contact the distal end of said dead latch bolt when said actuator element is in the first actuator position and said second actuator cam portion having a second cam surface operative to contact said distal end of said spring latch bolt when said actuator element is in the second actuator position.

9. A door latch actuator according to claim 7 wherein said driver causes said actuator element to pivot about an axis.

10. A door latch actuator according to claim 7 including a strike plate adapted to connect to said driver and to releasably attach to the doorjamb and over the latch bolt receiving cavity, said strike plate having a port adapted for the spring latch bolt and the dead latch bolt to extend therethrough and into the latch bolt receiving cavity in the doorjamb.

11. A door latch actuator according to claim 10 including a support element adapted to attach to said strike plate and to pivotally receive said actuator element.

12. A door latch actuator mounted within a latch bolt receiving cavity in a doorjamb and operative with a latch bolt assembly on a door that is pivotally mounted in a door frame

for moving the door between a first door position and a second door position wherein the latch bolt assembly includes a spring latch bolt and a dead latch bolt, both the spring latch bolt and dead latch bolt being spring biased to extend from the door and into the latch bolt receiving cavity when the door is at the first position, the spring latch bolt being slideably movable between an extended state and a retracted state and said dead latch bolt being slideably movable between an enable state which permits the spring latch bolt to move from the extended state to the retracted state and a disable state which prohibits the spring latch bolt from moving from the extended state to the retracted state, said door latch actuator comprising:

(a) a strike plate being adapted to releasably attach to the doorjamb and having a port adapted for the spring latch bolt and the dead latch bolt to extend therethrough and into the latch bolt receiving cavity in the doorjamb;

(b) an actuator element disposed in proximity to the distal ends of both said spring latch bolt and said door latch bolt and movable between first and second actuator positions, said actuator element when in the first actuator position operative to retain said dead latch bolt in the disable state while allowing said spring latch bolt to extend into the latch bolt receiving cavity in the extended state thereby to retain the door at the first door position in a secured condition, said actuator element operative upon movement from the first actuator position to the second actuator position to first allow said dead latch bolt to move into the enable state and then attack the distal end of said spring latch bolt to move said spring latch bolt from the extended state to the retracted state thereby causing the door to be in an unsecured condition at the first door position so that the door can be moved from the first door position to the second door position; and

(c) a driver adapted to connect to said strike plate and operative to move said actuator element between the first and second actuator positions.

AMENDED CLAIMS

[received by the International Bureau on 24 June 1996 (24.06.96);
original claim 7 amended; remaining claims unchanged (1 page)]

said driver includes an electric motor and a gear assembly operably connected to and between said electric motor and said cam.

5. A door latch actuator according to claim 3 including a controller device operative to reversibly activate said driver whereby said cam is caused to pivot between the first and second actuator positions.

6. A door latch actuator according to claim 5 wherein said controller device includes timer circuitry operative after said cam moves from the first actuator position to the second actuator position to cause said cam to return to the first actuator position upon expiration of a selected period of time.

7. A door latch actuator mounted in a latch bolt receiving cavity in a doorjamb and operative with a latch bolt assembly on a door that is pivotally mounted in a door frame for movement between a first door position and a second door position wherein the latch bolt assembly includes a spring latch bolt and a dead latch bolt which have distal ends respectively being spring biased to extend into the latch bolt receiving cavity when the door is in the first door position, said spring latch bolt being slideably movable between an extended state and a retracted state and said dead latch bolt being slideably movable between an enable state which permits the spring latch bolt to move from the extended state to the retracted state and a disable state which prohibits the spring latch bolt from moving from the extended state to the retracted state, said door latch actuator comprising:

(a) an actuator element disposed in proximity to the distal ends of both said spring latch bolt and said dead latch bolt when the door is in the first position and movable between a first and second actuator position, said actuator element when in the first actuator position operative to retain said dead latch bolt in the disable state while allowing said spring latch bolt to extend into the latch bolt receiving cavity in the extended state thereby to retain the door at the first door position in a secured condition, said actuator

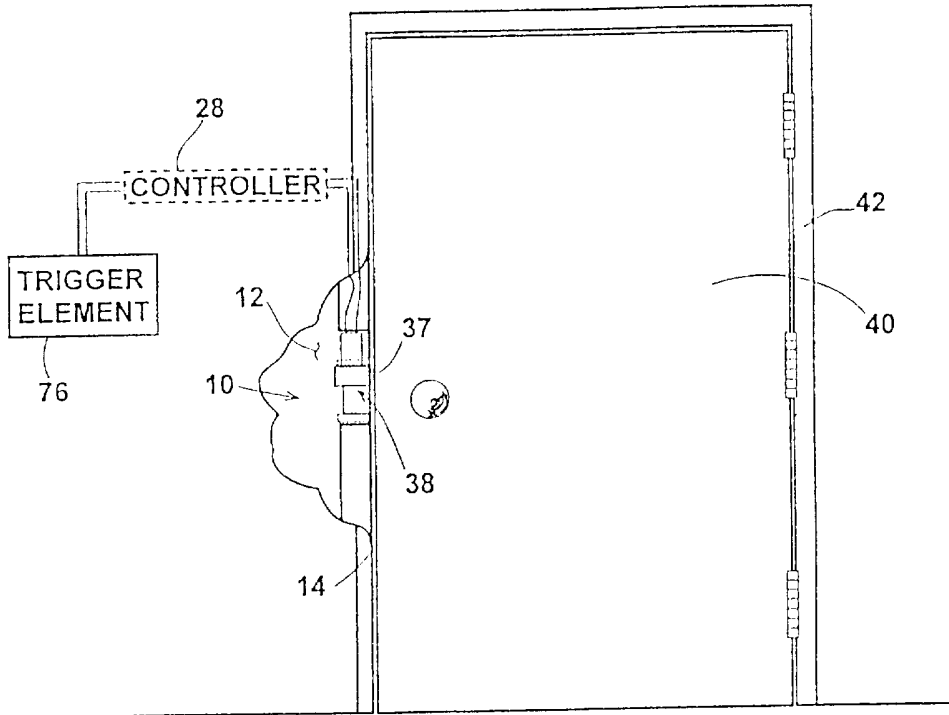

FIG. 1

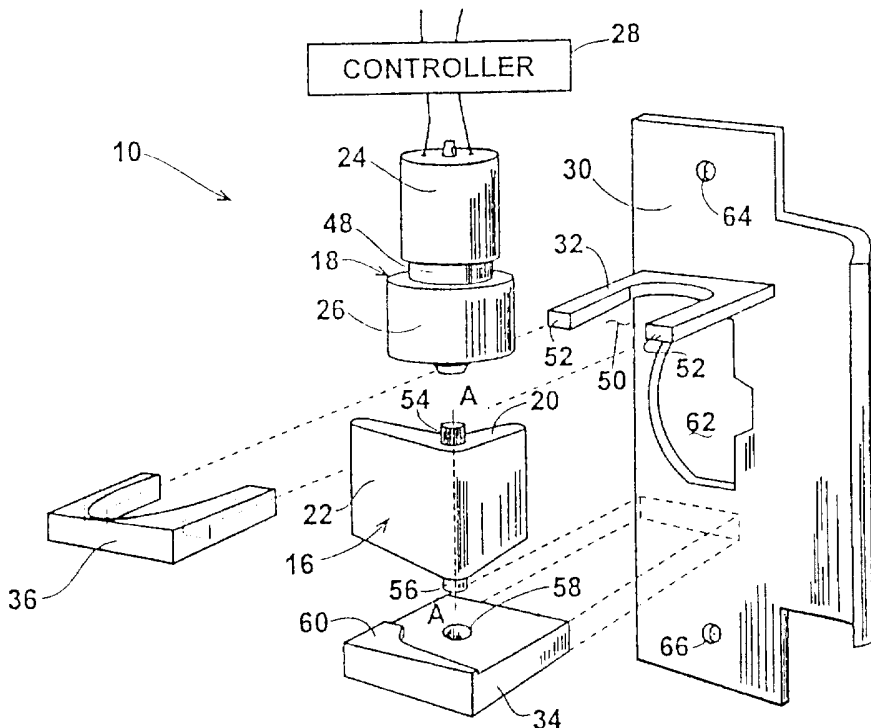

FIG. 2

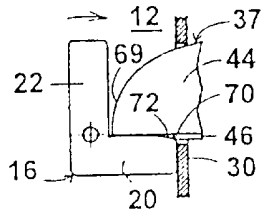

FIG. 5(A)

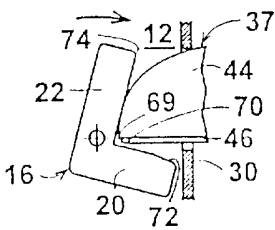

FIG. 5(B)

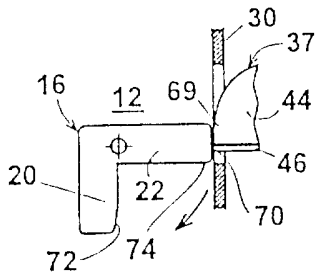

FIG. 5(C)

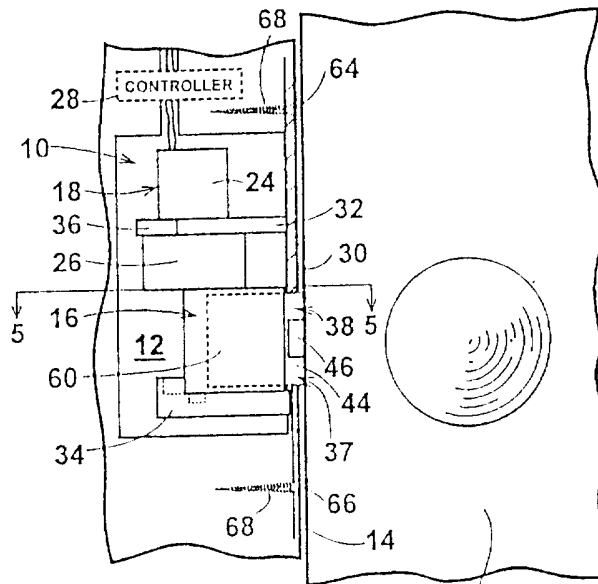

FIG. 4

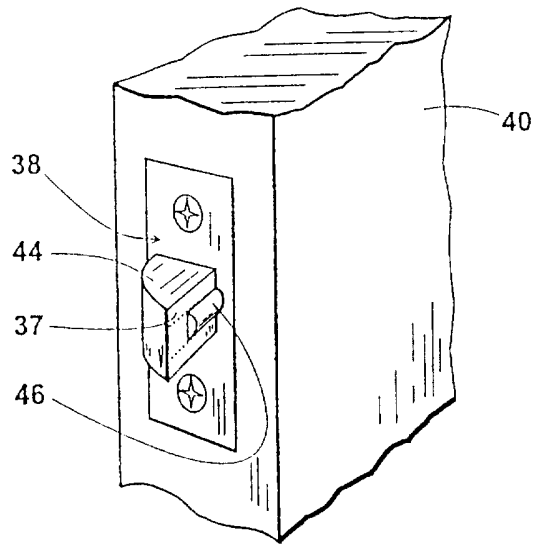

FIG. 3

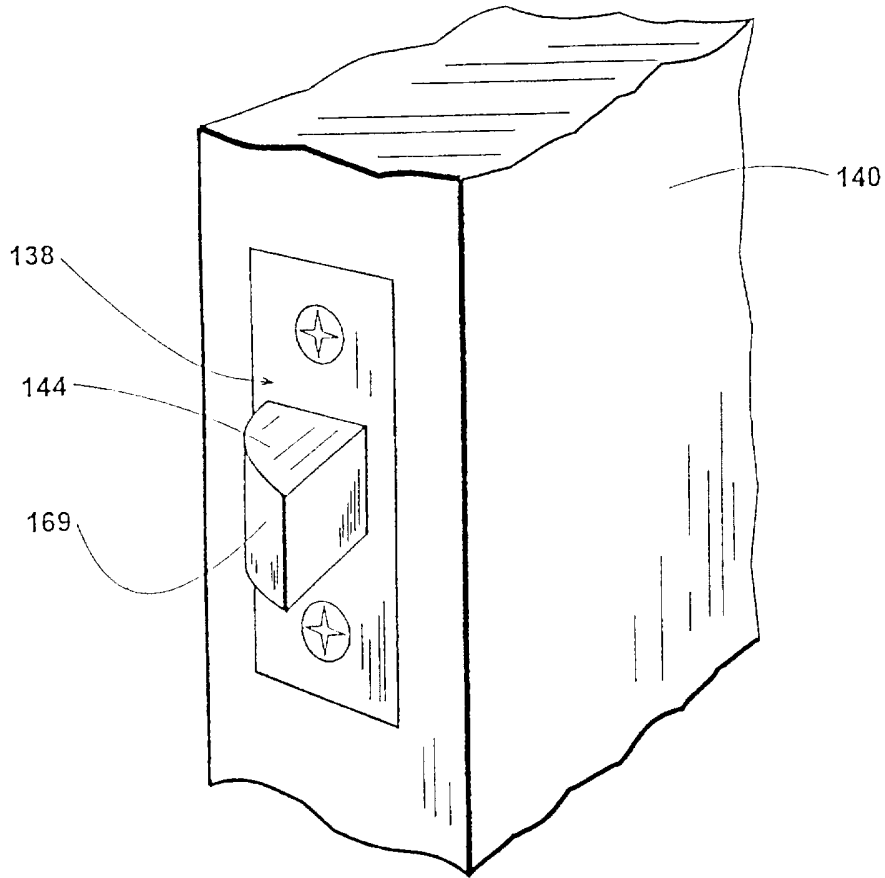

FIG. 6

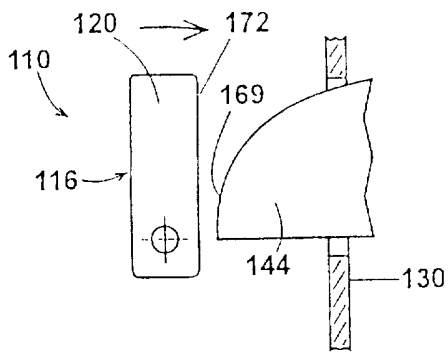

FIG. 7(A)

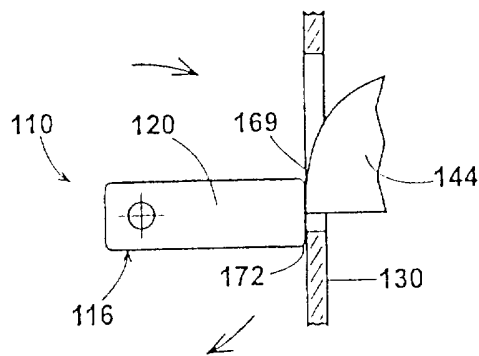

FIG. 7(B)

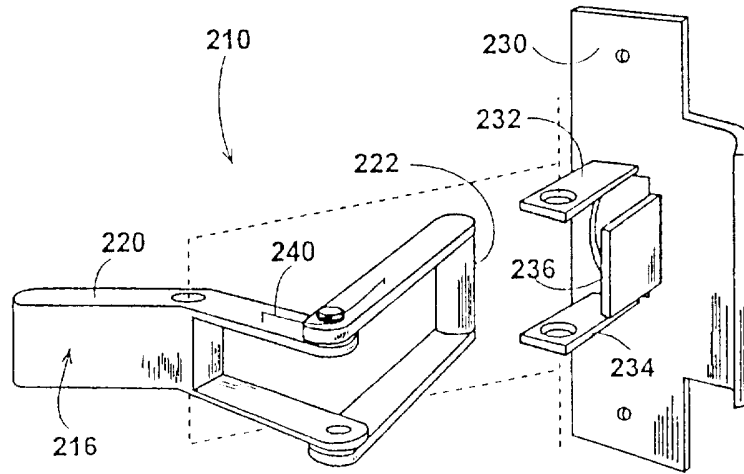

FIG. 8

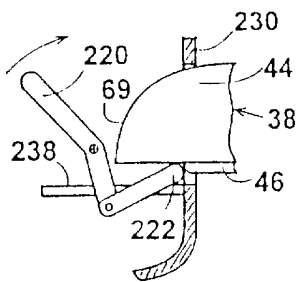

FIG. 9(A)

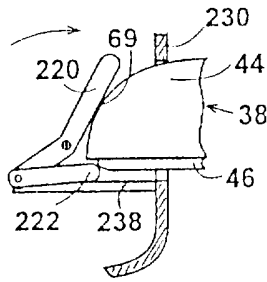

FIG. 9(B)

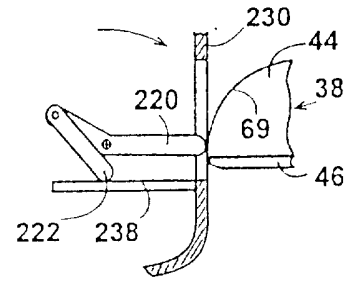

FIG. 9(C)

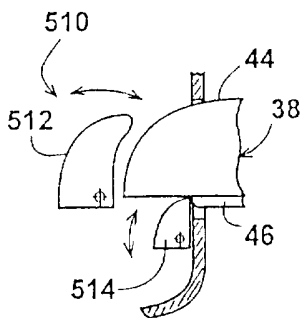

FIG. 12

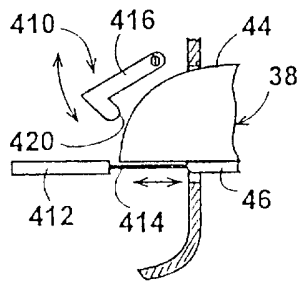

FIG. 11

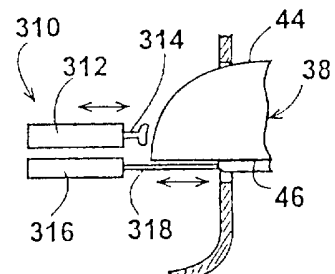

FIG. 10

INTERNATIONAL SEARCH REPORT

International application No.
PCT/US95/16666

A. CLASSIFICATION OF SUBJECT MATTER

IPC(5) :E05B 15/00

US CL : 292/254, 341.16

According to International Patent Classification (IPC) or to both national classification and IPC

B. FIELDS SEARCHED

Minimum documentation searched (classification system followed by classification symbols)

U.S. : 292/254, 341.16, 341.17, 201

Documentation searched other than minimum documentation to the extent that such documents are included in the fields searched

Electronic data base consulted during the international search (name of data base and, where practicable, search terms used)

C. DOCUMENTS CONSIDERED TO BE RELEVANT

Category*	Citation of document, with indication, where appropriate, of the relevant passages	Relevant to claim No.
X	US, A, 3,521,921 (MIYAZAKI) 28 July 1970, col. 4, lines 48-66.	1,2,7,10-12
A	US, A, 4,679,834 (GOTANDA) 14 July 1987.	1-12

Further documents are listed in the continuation of Box C.

See patent family annex.

* Special categories of cited documents:	"T" later document published after the international filing date or priority date and not in conflict with the application but cited to understand the principle or theory underlying the invention
"A" document defining the general state of the art which is not considered to be of particular relevance	"X" document of particular relevance; the claimed invention cannot be considered novel or cannot be considered to involve an inventive step when the document is taken alone
"E" earlier document published on or after the international filing date	"Y" document of particular relevance; the claimed invention cannot be considered to involve an inventive step when the document is combined with one or more other such documents, such combination being obvious to a person skilled in the art
"L" document which may throw doubts on priority claim(s) or which is cited to establish the publication date of another citation or other special reason (as specified)	"&" document member of the same patent family
"O" document referring to an oral disclosure, use, exhibition or other means	
"P" document published prior to the international filing date but later than the priority date claimed	

Date of the actual completion of the international search

09 APRIL 1996

Date of mailing of the international search report

24 APR 1996

Name and mailing address of the ISA/US
Commissioner of Patents and Trademarks
Box PCT
Washington, D.C. 20231

Facsimile No. (703) 305-3230

Authorized officer

RODNEY M. LINSEY

Telephone No. (703) 308-2168