

(No Model.)

J. P. COLEMAN.
SIGNAL APPARATUS.

2 Sheets—Sheet 1

No. 526,179.

Patented Sept. 18, 1894.

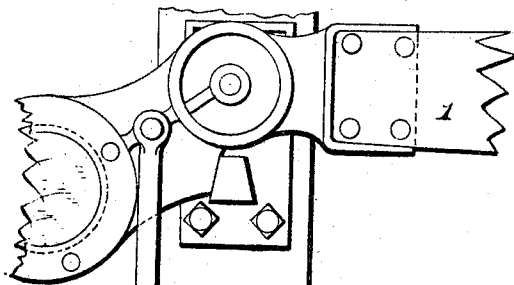

FIG. 1.

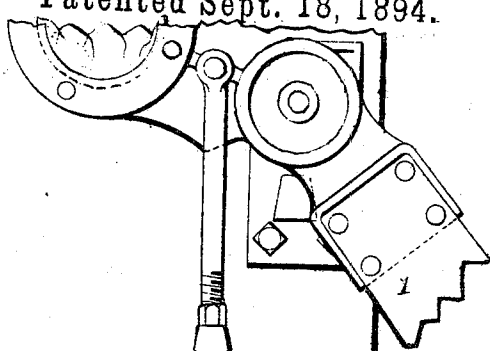
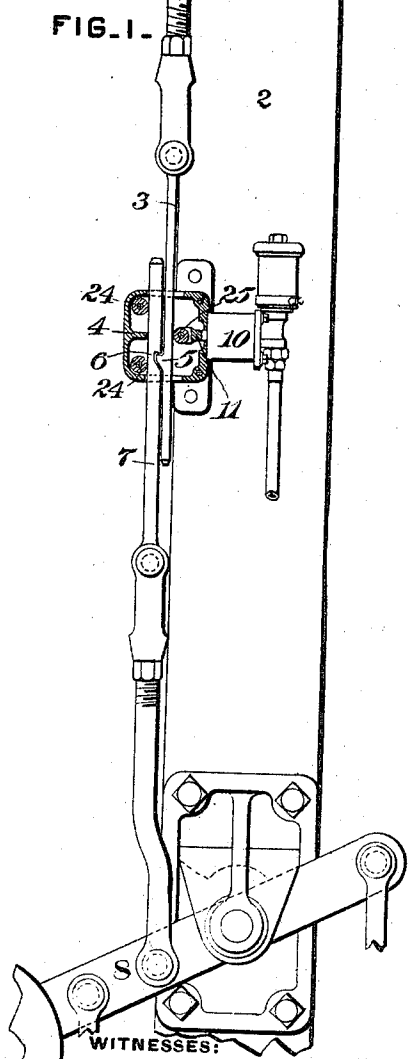
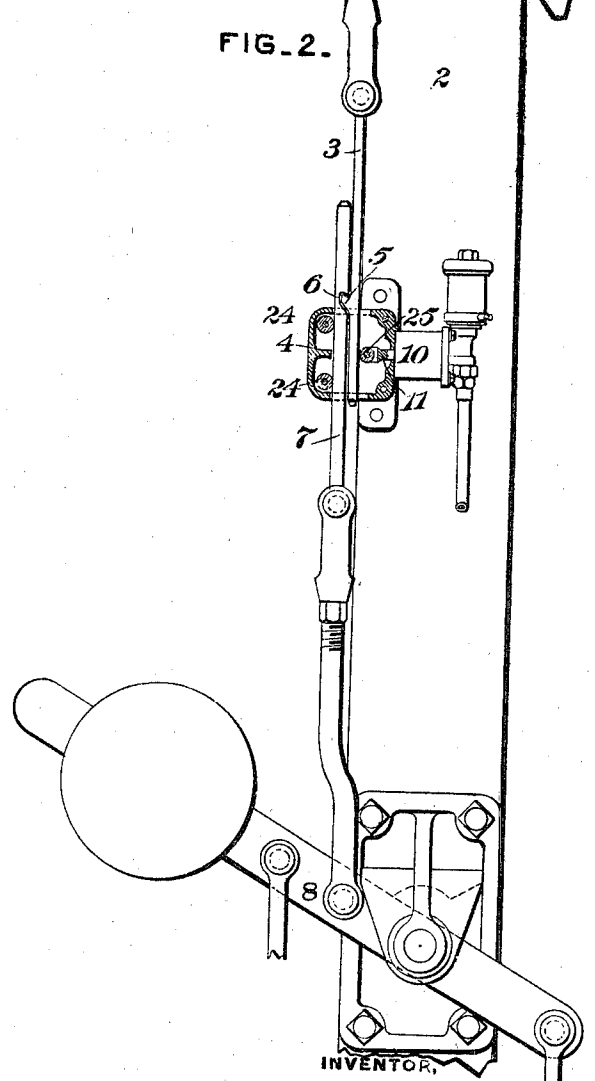

FIG. 2.



WITNESSES:

Danwin b. Wolcott
C. E. Hunt.



INVENTOR,

John Pressley Coleman
by George H. Christy
Att'y.

(No Model.)

2 Sheets—Sheet 2.

J. P. COLEMAN.
SIGNAL APPARATUS.

No. 526,179.

Patented Sept. 18, 1894.

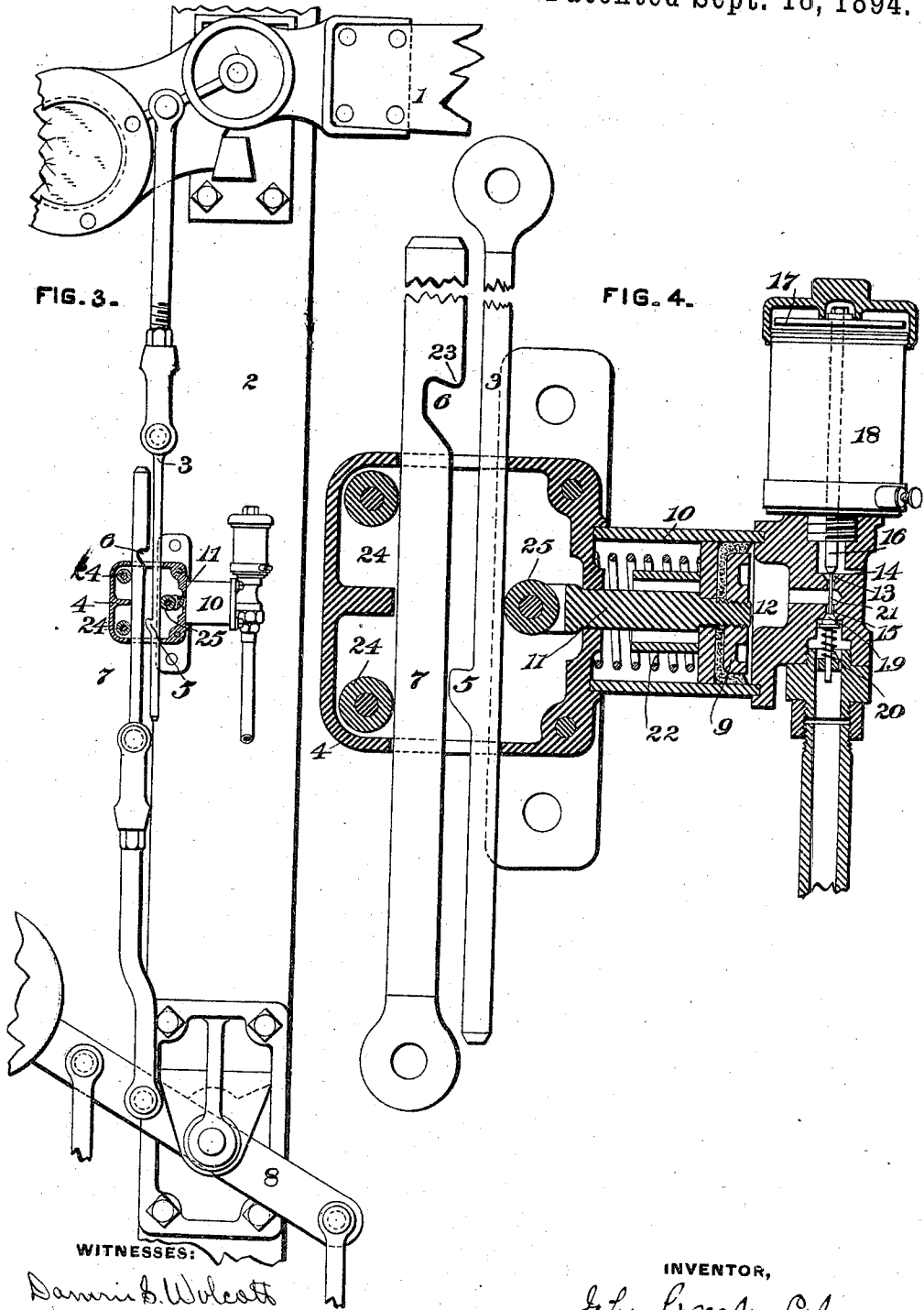

FIG. 3.

FIG. 4.

WITNESSES:

Daniel B. Wolcott
C. Hunt.

INVENTOR,

John Pressley Coleman
by George H. Christy
Att'y.

UNITED STATES PATENT OFFICE.

JOHN PRESSLEY COLEMAN, OF SWISSVALE, PENNSYLVANIA, ASSIGNOR TO
THE UNION SWITCH AND SIGNAL COMPANY, OF SAME PLACE.

SIGNAL APPARATUS.

SPECIFICATION forming part of Letters Patent No. 526,179, dated September 18, 1894.

Application filed December 2, 1893. Serial No. 492,571. (No model.)

To all whom it may concern:

Be it known that I, JOHN PRESSLEY COLEMAN, a citizen of the United States, residing at Swissvale, in the county of Allegheny and State of Pennsylvania, have invented or discovered certain new and useful Improvements in Signal Apparatus, of which improvements the following is a specification.

The invention described herein relates generally to certain improvements in electric slots for signals, but more especially to that class of slots employed in connection with pneumatic switch and signal apparatus, and the invention consists in the construction and combination substantially as hereinafter described and claimed.

In the accompanying drawings forming a part of this specification, Figure 1 is a view partly in elevation and partly in section, of a signal having my improvement applied thereto, the signal being shown at normal or danger. Fig. 2 is a similar view showing the signal at safety. Fig. 3 is a like view, the signal being shown at danger, on account of the operation of the slot mechanism; and Fig. 4 is an enlarged sectional view of the slot mechanism.

In the practice of my invention, the signal 1, which is preferably of the semaphore type, is pivotally mounted upon a post or standard and is provided at its lantern end with a weight so that when free to move, the blade will be automatically shifted to a horizontal or danger position. A rod 3 preferably jointed, is pivotally connected to the signal and extends down through a box or case 4. The rod 3 is provided with a tooth 5, adapted to engage a notch 6 in the rod 7, passing through the box parallel or approximately so to the rod 3 and connected at its lower end to a lever 8 or other signal operating device. The tooth on the rod 3 is normally held in engagement with the notch in the rod 7 by fluid pressure operating through the medium of the piston 9 in the cylinder 10. This cylinder is secured to one side of the case or shell 4, and the rod 11 of the piston passes through an opening in the side of the box so as to engage and press the rod 3 laterally toward the rod 7, when fluid pressure is admitted to the cylinder 10.

In the head of the cylinder 10 is formed a port 12, connecting the cylinder on the one hand with the exhaust ports 13 and 14, and on the other with the fluid pressure supply port 15. The escape of fluid pressure through the port 13 is controlled by the valve shaped end of the stem 16 of the armature 17 of the electro-magnet 18, and the admission of fluid pressure is controlled by the valve 19, which, when free to move, is forced to its seat by a spring 20 surrounding the stem of the valve. A pin 21 is interposed between the end of the stem 16 and the valve 19, said pin being of such a length that when the stem is moved down to close the port 13 by reason of the attraction of the armature to its magnet, the valve 19 will be forced from its seat to admit fluid pressure to the cylinder 10. The spring 20 not only serves to seat the valve 19, but also, through the medium of the pin 21, to push the armature from its magnet, when the circuit of the latter is broken.

The admission of fluid pressure to the cylinder 10 forces the piston and its rod in a direction to cause the tooth on the rod 3 to engage the notch 6, and at the same time, to compress the spring 22, which, upon the escape of fluid pressure from the cylinder, will shift the piston in the opposite direction.

In order that the tooth 5 may become disengaged from notch 6, the under side of the tooth and the corresponding side of the notch are inclined as shown, so that when the rod 3 is free to move laterally the tooth will slide out of the notch, and thus permit the signal to assume a horizontal or danger position, as shown in Fig. 3, if it has previously been shifted to safety position, as shown in Fig. 2, the rod 3 sliding down alongside of the rod 7.

It will be observed that in order to shift and maintain the signal at safety position, it is necessary that not only the circuit of the magnet 18 should be complete, but also that the connection between the fluid pressure supply and the cylinder 10 should be unbroken.

In order to provide for a return of the signal to danger in case it becomes stuck at safety by snow or sleet, the point 23 formed by notching the rod 7 and the tooth 5, is so

constructed, and the rods 3 and 7 are held in such position relative to each other by the rod of the piston 9, even when the latter is pushed back by the spring 22, that the point 23 will not clear the tooth and hence, when the rod 7 is drawn by the lever 8, the rod 3 will be pulled down restoring the signal to normal position, as shown in Fig. 4.

In order to permit of the easy vertical movement of the rods 3 and 7, when held together, friction rollers 24 are arranged in the case or shell to form bearing surfaces for the rod 7, and a friction roller 15 is mounted on the end of the rod of the piston 9.

The valve mechanism need not be arranged on the end of the cylinder 10, but may be arranged at any suitable point along the line of the fluid pressure supply pipe.

I claim herein as my invention—

1. In a signaling apparatus, the combination of a signal, mechanism for shifting the signal, two rods provided with interlocking devices for connecting the signal with its operating mechanism, and a fluid pressure mechanism

for holding the rods in engagement with each other, substantially as set forth.

2. In a signaling apparatus, the combination of a signal, operating mechanism detachably connected to the signal, and a fluid pressure mechanism controlling the connection between the signal and its operating mechanism, substantially as set forth.

3. In a slot mechanism for signals, the combination of two rods connecting the signal with its operating mechanism, said rods being provided with interlocking devices, a fluid pressure cylinder and piston for holding the rods in engagement with each other, and an electrically controlled valve mechanism for controlling the admission and exhaust of fluid pressure to and from the cylinder, substantially as set forth.

In testimony whereof I have hereunto set my hand.

JOHN PRESSLEY COLEMAN.

Witnesses:

J. C. MOCK,
GEO. D. FOWLE.