

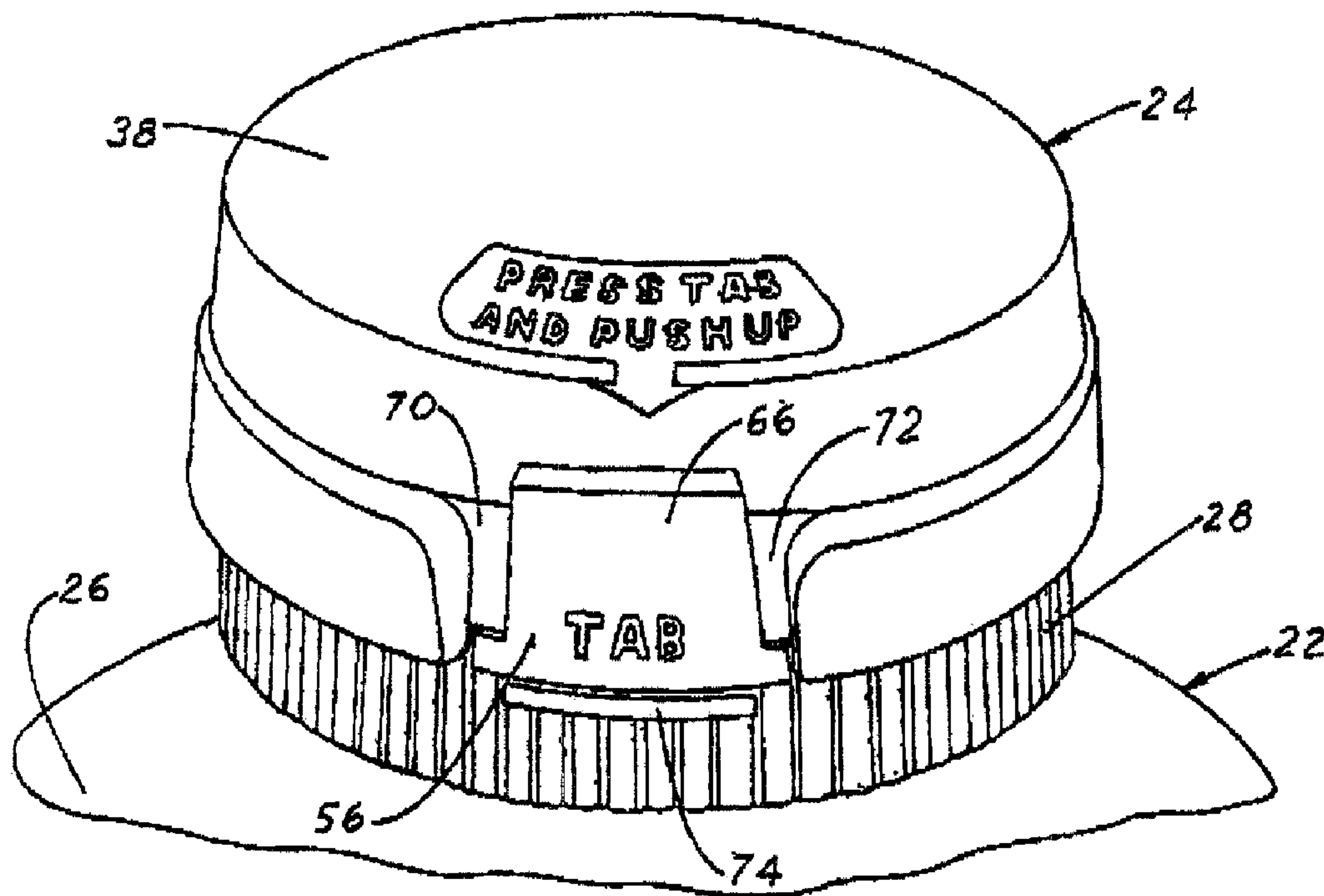

(22) Date de dépôt/Filing Date: 2004/07/23  
 (41) Mise à la disp. pub./Open to Public Insp.: 2005/01/28  
 (45) Date de délivrance/Issue Date: 2008/12/23  
 (30) Priorité/Priority: 2003/07/28 (US10/628,521)

(51) Cl.Int./Int.Cl. *B65D 50/04* (2006.01),  
*B65D 47/08* (2006.01)  
 (72) Inventeur/Inventor:  
KEUNG, WING-KWONG, US  
 (73) Propriétaire/Owner:  
REXAM CLOSURE SYSTEMS INC., US  
 (74) Agent: GOWLING LAFLEUR HENDERSON LLP

(54) Titre : EMBALLAGE ET FERMETURE DE DISTRIBUTION A ABATTANT A L'EPREUVE DES ENFANTS  
 (54) Title: CHILD-RESISTANT FLIP-TOP DISPENSING CLOSURE AND PACKAGE



(57) Abrégé/Abstract:

A child-resistant dispensing closure includes a base having a deck with a dispensing opening and a peripheral skirt. A lid is integrally molded with the base and coupled by a hinge to a periphery of the base so as to be pivotable between closed and open positions. One of the base and the lid has a latch arm resiliently extending from its periphery diametrically opposite the hinge. The latch arm has a pair of oppositely extending tabs adjacent to a free end of the arm. The other of the base and the lid has an axial passage for receiving the latch arms, and a pair of laterally spaced ledges in the passage for engagement by the tabs to lock the lid in the closed position. The latch arm is directly manually engageable by a user from a radial direction external to the closure to pivot the latch arm radially inwardly within the passage and release the tabs from the ledges so that the lid can be pivoted to the open position.

**Abstract of the Disclosure**

A child-resistant dispensing closure includes a base having a deck with a dispensing opening and a peripheral skirt. A lid is integrally molded with the base and coupled by a hinge to a periphery of the base so as to be pivotable between closed and open positions. One of the base and the lid has a latch arm resiliently extending from its periphery diametrically opposite the hinge. The latch arm has a pair of oppositely extending tabs adjacent to a free end of the arm. The other of the base and the lid has an axial passage for receiving the latch arm, and a pair of laterally spaced ledges in the passage for engagement by the tabs to lock the lid in the closed position. The latch arm is directly manually engageable by a user from a radial direction external to the closure to pivot the latch arm radially inwardly within the passage and release the tabs from the ledges so that the lid can be pivoted to the open position.

RCC:bu

17853F

**CHILD-RESISTANT FLIP-TOP DISPENSING CLOSURE AND PACKAGE**

The present invention is directed to hinged flip-top dispensing closures and packages, and more particularly to provision of a child-resistance feature on such a closure and package.

**Background and Summary of the Invention**

5 U.S. patents 4,638,916 and 5,489,035 disclose dispensing closures of one-piece integrally molded plastic construction. These closures include a base with a dispensing opening and an internally threaded skirt for securement to a container finish. A lid is integrally connected by a hinge to the periphery of the base. It is a general object of the present invention to provide a dispensing closure of this type having a feature that resists opening by a child.

10 A child-resistant dispensing closure in accordance with a first aspect of the present invention includes a base having a deck with a dispensing opening and a peripheral skirt. A lid is integrally molded with the base and coupled by a hinge to the base so as to be pivotable between closed and open positions. One of the base and the lid has a latch arm resiliently extending from its periphery diametrically opposite the hinge. The latch arm has a pair of  
15 oppositely extending tabs adjacent to a free end of the arm. The other of the base and the lid has an axial passage for receiving the latch arm, and a pair of laterally spaced ledges in the passage for engagement by the tabs to lock the lid in the closed position. The latch arm is directly manually engageable by a user from a radial direction external to the closure to pivot the latch arm radially inwardly within the passage and release the tabs from the ledges so that the lid can  
20 be pivoted to the open position.

**Brief Description of the Drawings**

The invention, together with additional objects, features and advantages thereof, will be best understood from the following description, the appended claims and the accompanying drawings in which:

5           FIG. 1 is a fragmentary perspective view of a child-resistant closure and container package in accordance with one presently preferred embodiment of the invention;

          FIG. 2 is a fragmentary perspective view of the closure in the package of FIG. 1;

          FIG. 3 is a top plan view of the closure in the package of FIG. 1;

          FIG. 4 is a sectional view taken substantially along the line 4-4 in FIG. 3;

10           FIGS. 5 and 6 are end elevational views of the closure taken from the respective directions 5 and 6 in FIG. 4;

          FIG. 7 is a fragmentary sectional view on an enlarged scale of the portion of FIG. 4 within the area 7;

          FIG. 8 is an enlargement of a portion of FIG. 7;

15           FIG. 9 is a top plan view of a closure in accordance with a modified embodiment of the invention;

          FIGS. 10, 11 and 12 are sectional views taken substantially along the respective lines 10-10, 11-11 and 12-12 in FIG. 9;

20           FIG. 13 is a fragmentary sectional view on an enlarged scale of the portion of FIG. 10 within the area 13;

          FIG. 14 is a perspective view of a child resistant dispensing closure in accordance with another embodiment of the invention; and

          FIGS. 15 and 16 are respective fragmentary perspective views of the base and lid portions of the closure in FIG. 14.

### Detailed Description of Preferred Embodiments

FIG. 1 illustrates a child-resistant closure and container package 20 in accordance with one presently preferred embodiment of the invention as comprising a container 22 and a dispensing closure 24 secured to the container finish. Container 22 has a body 26 of flexible resilient construction, preferably molded plastic construction, that may be squeezed by a user to dispense product through closure 24 from within the container. Referring to FIGS. 1-8, closure 24 includes a base 28 having a deck 30 and a peripheral skirt 32. Skirt 32 has one or more internal threads or beads 34 for securement over one or more external threads or beads on the finish of container 22. A discharge or dispensing opening 36 is formed in deck 30, preferably although not necessarily by an annular upwardly extending wall. (Directional words such as "upward" and "downward" are employed by way of description and not limitation with respect to the upright orientation of the package and closure illustrated, for example, in FIGS. 1-2 and 4-6. Directional words such as "radial," "axial" and "lateral" are employed by way of description and not limitation with respect to the central axis of the closure skirt.) A cover or lid 38 is coupled to base 30 by a hinge 40 that extends between lid 38 and base 28, preferably but not necessarily between the periphery of lid 38 and the periphery of base 28. Closure 24, including base 28 and lid 38, preferably is of integrally molded plastic construction. In the embodiment of closure 24 illustrated in FIGS. 3- 8, an annular wall 42 extends from the base wall 44 of lid 38 for plug-sealing engagement within dispensing opening 32 in the closed position of lid 38 overlying deck 30 of base 28.

In the particular embodiment of closure 24 illustrated in FIGS. 1-8, lid 38 has a base wall 44 and a peripheral skirt 46. A bead 48 extends around the inside surface of lid skirt 46 for sealing engagement with a radially outwardly facing surface 50 on base 28, which forms an axially facing ledge 52 recessed beneath the upper surface of deck 30. There preferably is a

segmented bead 53 (FIGS. 5-6) on surface 50 that cooperates with bead 48 on lid 38 to hold the lid closed by snap fit, with the axial edge of skirt 46 in abutment with ledge 52. Hinge 40 preferably is of the type illustrated in U.S. Patent 6,041,477. Hinge 40 alternatively, but less preferably, may be of the type illustrated in U.S. patents 4,638,916 and 5,489,035 noted above, or any other suitable single-element or multiple-element type. An array of internal teeth 41 preferably, although not necessarily, extends around the inside of skirt 36 adjacent to the free end of the skirt for cooperating with similar teeth on the container to make the closure non-removable.

In accordance with the embodiment of the invention illustrated in FIGS. 1-8, a latch arm 56 extends from the periphery of lid 38 at a position diametrically opposed to hinge 40. Latch arm 56 preferably is T-shaped as viewed from the radial direction (FIG. 6), having a center leg 58 coupled to and extending axially from the free edge of lid skirt 46 in this embodiment, and having a pair of tabs 60, 62 extending laterally from the free end of leg 58. Tabs 60, 62 are formed in the illustrated embodiment at opposed ends of a bar 64 that extends across the free end of latch leg 58 in a direction parallel to lid base wall 44. Tabs 60, 62 alternatively may extend from the side edges of leg 58, although use of a thickened bar 64 is preferred to strengthen the end of the latch arm. Latch arm 56 is flexibly and resiliently coupled to lid 38 by reason of the flexibility of lid skirt 46. An external bead 66 (FIGS. 3, 6 and 8) extends across leg 58 of latch arm 56 adjacent to the edge of skirt 46 in the preferred embodiments of the invention for engagement by a user's thumb to open the closure, as will be described. As best seen in FIG. 3, latch arm 56, including leg 58 and bar 64, are arcuate as viewed from the axial direction in this embodiment of the invention, following the peripheral contour of lid 38. Tabs 60, 62 thus extend circumferentially in this embodiment of the invention, in which base 28 and lid 38 have circular geometries. Base 28 and lid 38 may have other peripheral geometries, such as oval or polygonal.

A rib 67 preferably extends axially along the inside surface of lid skirt 46 and latch arm leg 58, circumferentially centered on arm 56 as best seen in FIG. 3, to strengthen the resilient coupling of the latch arm to the lid.

An axial passage 68 extends along the outer surface of base skirt 32 at a position diametrically opposite hinge 40. Passage 68 opens to deck 30 at its upper end, and opens to the radial outer surface of skirt 32. Passage 68 thus in essence comprises a pocket or recess in the outer surface of skirt 32 in this embodiment of the invention, which opens at its upper end to deck 30 of base 28. As best seen in FIG. 3, passage 68 is arcuate as viewed from the axial direction, being contoured to receive latch arm 56 as will be described. A pair of laterally spaced ledges 70, 72 are provided at the laterally or circumferentially opposed edges of passage 68. Each ledge 70, 72 has an associated flat undersurface 71, 73, and a radially outer surface that slopes radially outwardly and axially downwardly in the orientation of FIGS. 4-5. Passage 68 is open behind ledges 70, 72 to permit passage of latch arm 56, as will be described.

As lid 38 is pivoted about hinge 40 from the open position illustrated in FIGS. 3-6 toward the closed position illustrated in FIGS. 1-2, tabs 60, 62 of latch arm 56 engage and slide along the radially outwardly facing surfaces of ledges 70, 72. These outer surfaces, being angulated with respect to the axis of the closure skirt, cam the free end of the latch arm radially outwardly as the lid is closed, resiliently flexing latch arm 56 radially outwardly with respect to the body of lid 38. When tabs 60, 62 reach the lower ends of ledges 70, 72, resiliency of the latch arm and the lid connection snaps tabs 60, 62 radially inwardly beneath undersurfaces 71, 73 of ledges 70, 72 to the fully closed position of the lid illustrated in FIGS. 1 and 2. In this position, leg 58 of latch arm 56 is received between ledges 70, 72 in passage 68, and tabs 60, 62 are captured beneath ledges 70, 72. Lid 38 cannot be opened by simply pulling upwardly on the lid because tabs 60, 62 of latch arm 56 cooperate with ledges 70, 72 in passage 68 to lock the lid in

the closed position. A rib 74 preferably, although not necessarily, is provided on the outer surface of skirt 32 immediately beneath passage 68 to help prevent opening of the closure by insertion of a pry tool such as a screwdriver beneath latch arm 56.

When it is desired to open the lid, a user pushes radially inwardly against the outer surface of latch arm 56, which is exposed between ledges 70, 72 of passage 68. Indicia may be provided on the closure to assist the user, as shown in FIGS. 1, 2 and 6. Arrowhead indicia may also be provided on the upper surface of lid 38, as shown in FIG. 1, to direct a user to the latch arm. When latch arm 56 is pushed radially inwardly into passage 68 to a sufficient extent that tabs 60, 62 clear undersurfaces 71, 73 of ledges 70, 72, the lid may be pushed and pivoted upwardly about hinge 40 to open the closure to dispense product. The back or radially inner surfaces of ledges 70, 72 are spaced from the back or radially inner wall of passage 68 to permit free axial passage of latch arm tabs 60, 62. Release of the latch mechanism and pivotal motion of the lid in this embodiment is a continuous motion that facilitates use by a person who understands operation of the mechanism, but resists opening by a child. Bead 66 on the outer surface of latch arm 56 facilitates upward pushing on the lid when latch arm 56 is depressed.

FIGS. 9-13 illustrate a child-resistant dispensing closure 76 in accordance with a modified embodiment of the invention. Elements in FIGS. 9-13 (and FIGS. 14-16) that are identified by reference numerals identical to those employed in FIGS. 1-8 indicate identical or similar components, and related components are designated with a letter suffix. Closure base 28a in FIGS. 9-13 includes a raised rib 84 adjacent to hinge 40 to help prevent entry of moisture between base 28a and lid 38a in the closed position of the lid. Dispensing opening 36a in FIGS. 8-13 is formed by an annular wall having an angulated upper edge that helps control dispensing of liquid product from within the package. A bead 53a (FIGS. 9 and 12) extends part-way around

wall 50 of base 28 and cooperates with bead 48 on skirt 46 of lid 38a to snap lid 38a in the closed position over base 28a.

FIGS. 14-16 illustrate a one-piece child-resistant dispensing closure 90 in accordance with another embodiment of the invention as including a base 28b integrally molded and connected to a lid 38b by means of a hinge 40. A latch arm 56b in this embodiment is  
5 resiliently coupled to skirt 32b of base 28b adjacent to the free edge of the skirt 32b. Latch arm 56b again is T-shaped, having a leg 58b coupled to skirt 32b, and a pair of laterally extending tabs 60b, 62b formed by a bar 64b that extends across the free edge of leg 58b. A passage 68b extends axially through the periphery of lid 38b at a position diametrically opposite hinge 40.  
10 Passage 68b has a pair of ledges 70b, 72b for engagement by tabs 60b, 62b of latch arm 56b. Passage 68b in lid 38b is radially outwardly enclosed by skirt 46b of lid 38b, and is radially inwardly enclosed by a wall 96 that limits inward movement of latch arm 56b. The radially outwardly directed surface of latch arm bar 64b in the embodiment of FIGS. 14-16 is disposed at an angle to the axis of the closure base. Likewise, the axially facing surfaces of ledges 70b,  
15 72b are disposed at an angle so as to cooperate with the angulated surface of latch arm bar 64b resiliently to cam the latch arm radially inwardly as lid 38b is closed over base 28b. When tabs 60b, 62b clear ledges 70b, 72b, the resilient connection between latch arm 56b and skirt 32b snaps the latch arm radially outwardly so that tabs 60b, 62b overlie opposing flat upper surfaces on ledges 70b, 72b to lock the lid in the closed position. To open the lid, latch arm 56b is pushed  
20 radially inwardly until tabs 60b, 62b clear ledges 70b, 72b, at which point lid 38b may be pivoted from the closed position toward the open position for dispensing product from within the package. Base skirt 32b has an open pocket 98 behind latch arm 56b to permit such inward flexing of the latch arm.

There have thus been disclosed a child-resistant closure, and a child-resistant closure and container package that fully satisfy all of the objects and aims previously set forth. The closure has been disclosed in conjunction with three presently preferred embodiments thereof, and a number of modifications and variations have been discussed. Other modifications and variations will readily suggest themselves to persons of ordinary skill in the art. The invention is intended to embrace all such modifications and variations as fall within the spirit and broad scope of the appended claims.

5

**Claims**

1.

1           A child-resistant dispensing closure that includes:  
2           a base having a deck with a dispensing opening and a peripheral skirt extending  
3           from said deck,  
4           a lid molded integrally with said base and coupled by a hinge to said base so as  
5           to be pivotable about said hinge between a closed position overlying said deck and an open  
6           position spaced from said deck,  
7           one of said base and said lid having a latch arm resiliently extending from a  
8           periphery thereof diametrically opposite said hinge, said latch arm having a pair of opposite  
9           extending tabs adjacent to a free end thereof,  
10           the other of said base and said lid having an axial passage for receiving said latch  
11           arm and a pair of laterally spaced ledges in said passage for engagement by said tabs to lock said  
12           lid in said closed position,  
13           said latch arm being directly manually engageable by a user from a radial direction  
14           external to said closure to pivot said latch arm radially inwardly within said passage and release  
15           said tabs from said ledges so that said lid can be pivoted to said open position.

2.

1           The closure set forth in claim 1 wherein said latch arm resiliently extends from  
2 a periphery of said lid diametrically opposite said hinge, and wherein said passage in said base  
3 is radially open at said skirt.

3.

1           The closure set forth in claim 2 wherein said ledges in said passage radially open  
2 at said skirt such that said latch arm may extend outside of said skirt as said lid is moved toward  
3 said closed position and then snap radially inwardly beneath said ledges due to resilience of said  
4 latch arm and connection between said latch arm and said lid.

4.

1           The closure set forth in claim 3 further including cam surfaces on said ledges  
2 adjacent to said open passage in said skirt for engagement by said tabs on said latch arm to cam  
3 said latch arm radially outwardly as said lid is moved toward said closed position.

5.

1           The closure set forth in claim 3 wherein said lid includes an internal rib on said  
2 latch arm for strengthening resilient coupling of said latch arm to said lid.

6.

1           The closure set forth in claim 1 wherein said latch arm resiliently extends from  
2 said base at a position diametrically opposite said hinge.

7.

1           The closure set forth in claim 6 wherein said latch arm is resiliently coupled to  
2 said skirt at a position spaced from said deck, said base having an open pocket in said skirt  
3 behind said latch arm to accommodate pivotal movement of said latch arm to release said lid.

8.

1           The closure set forth in claim 7 wherein said ledges on said lid, or said tabs on  
2 said latch arm, or both, have cam surfaces to cam said latch arm radially inwardly into said  
3 pocket as said lid is moved toward said closed position.

9.

1           The closure set forth in any one of claims 1 to 8 comprising cam surfaces  
2 on said ledges, said tabs on said latch arm, or both, for flexing said resilient latch arm to  
3 snap said tabs over said ledges as said lid is moved toward said closed position.

10.

1                   The closure set forth in any one of claims 1 to 9 wherein said latch arm is  
2 T-shaped, having a center leg coupled to said lid or said base and a pair of tabs extending  
3 laterally oppositely from a free end of said leg for engagement beneath said ledges.

11.

1                   A child-resistant closure and container package that includes a container  
2 and a dispensing closure as set forth in any one of claims 1 to 10.

12.

1                   A method of making a child-resistant dispensing closure that includes  
2 integrally molding a closure as set forth in any one of claims 1 to 10.

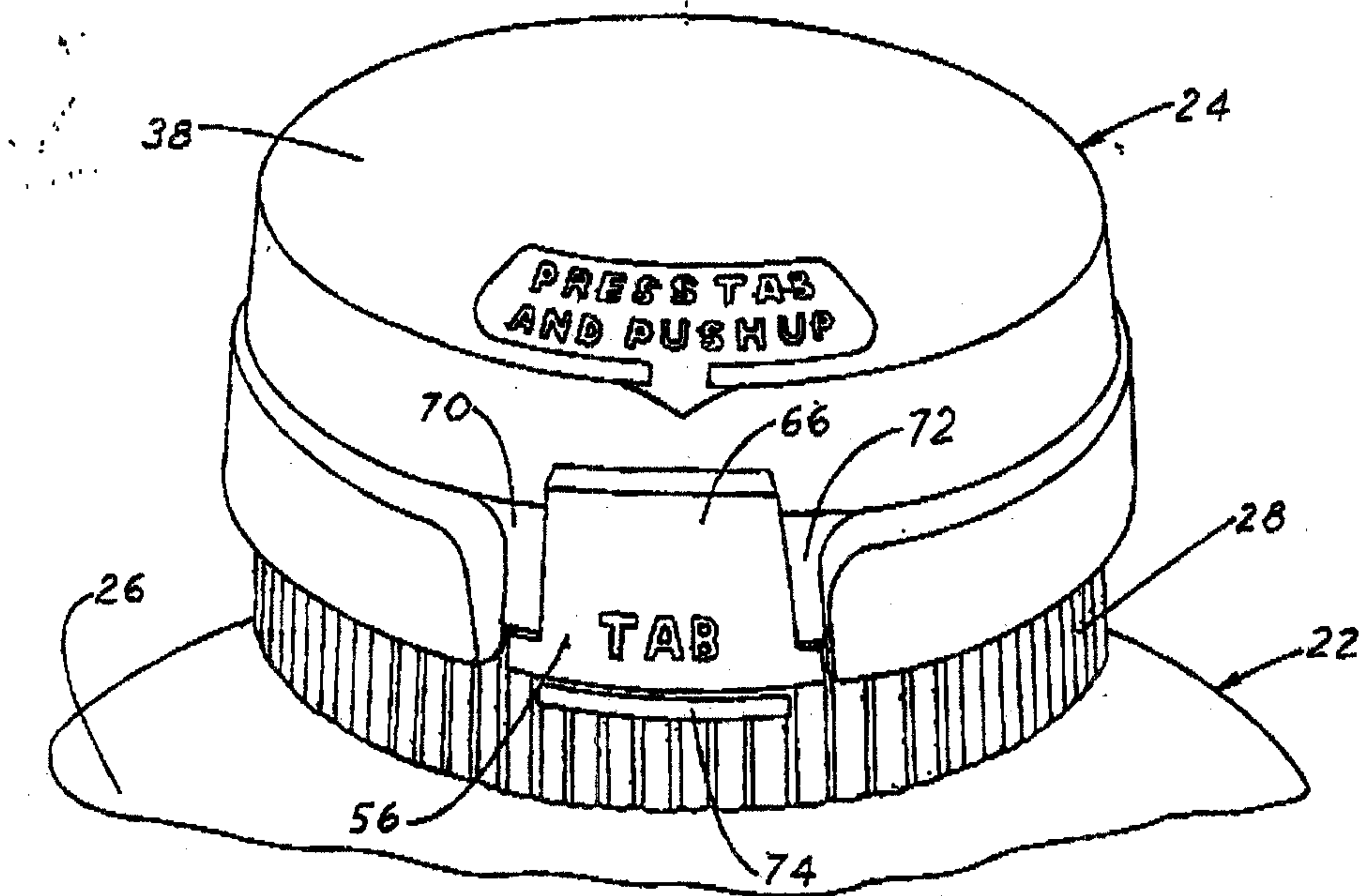

FIG. 1

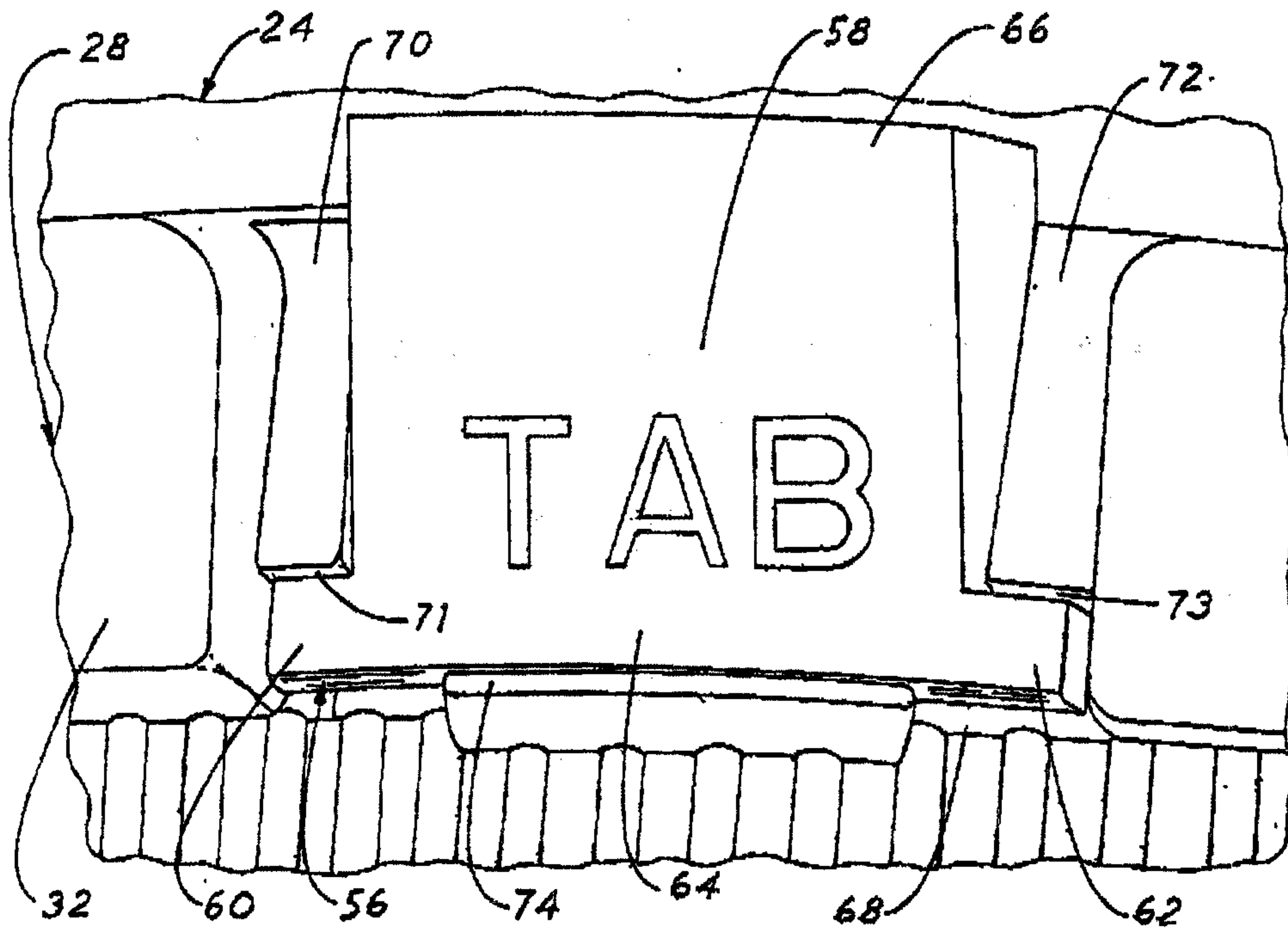

FIG. 2

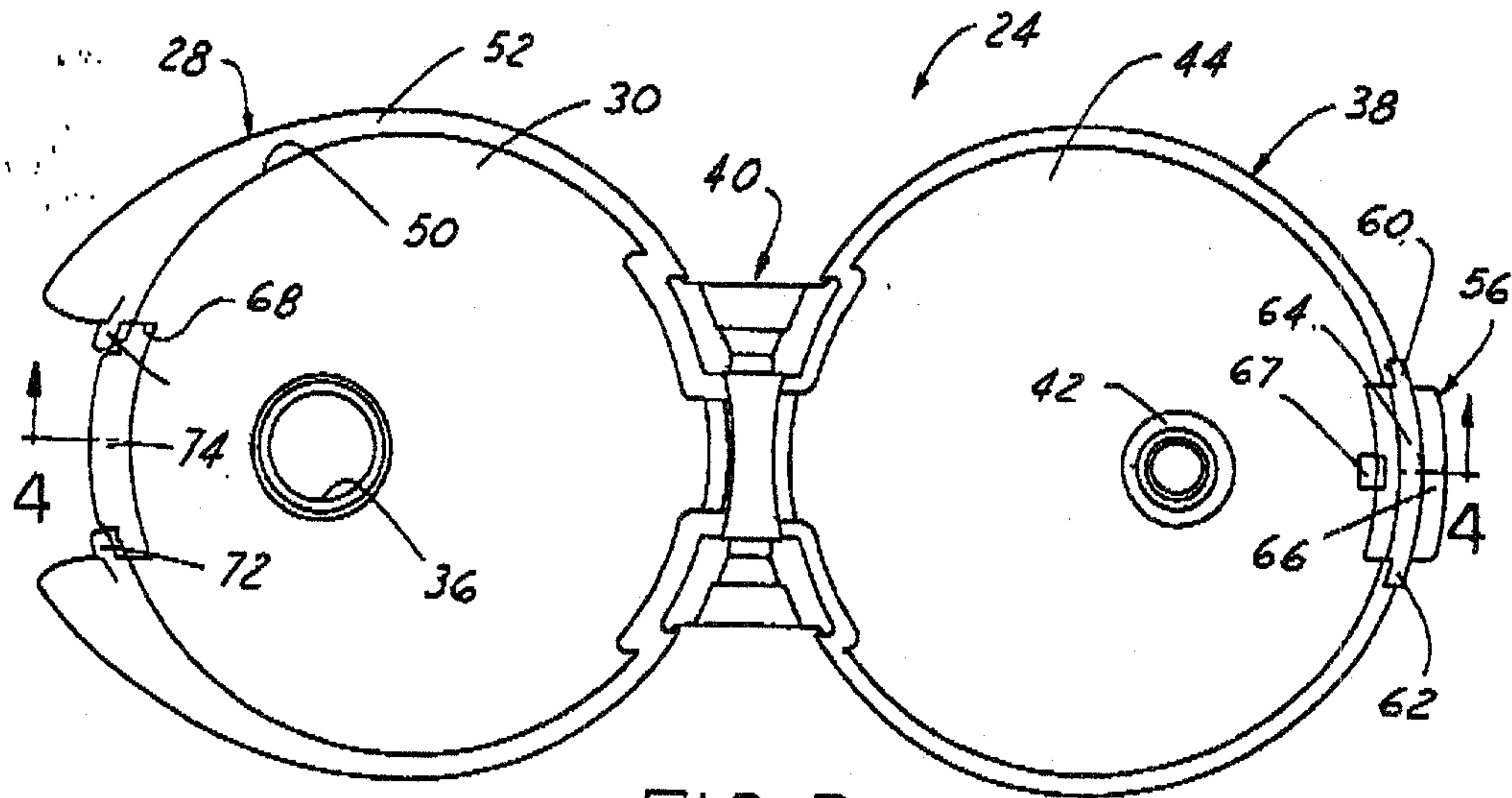

FIG. 3

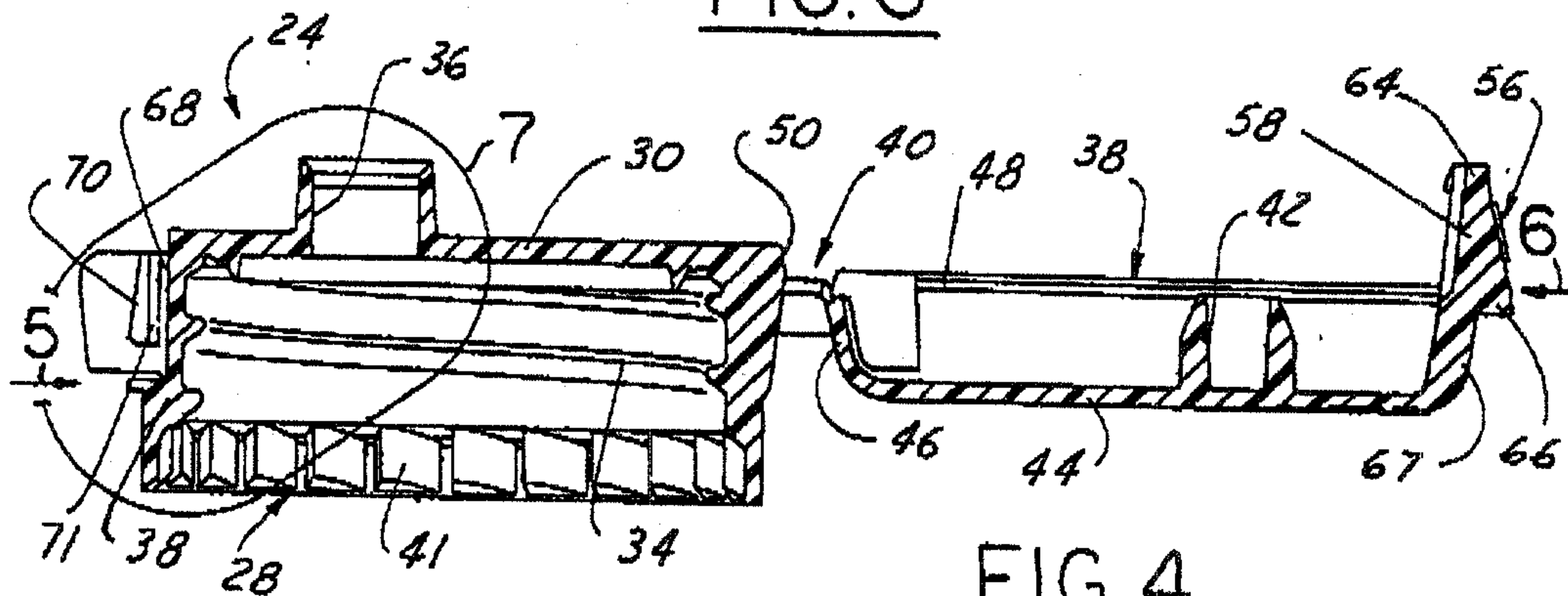

FIG. 4

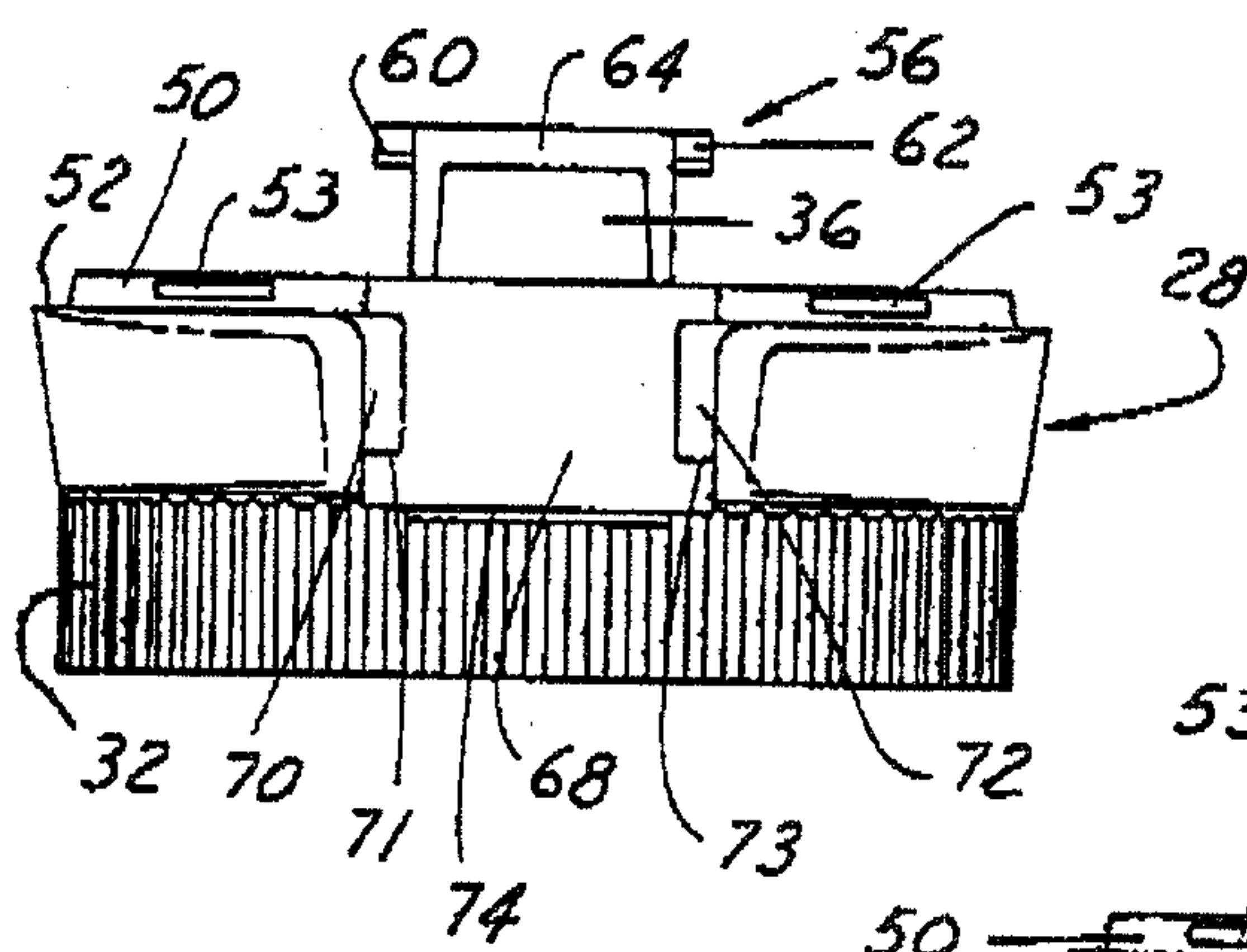
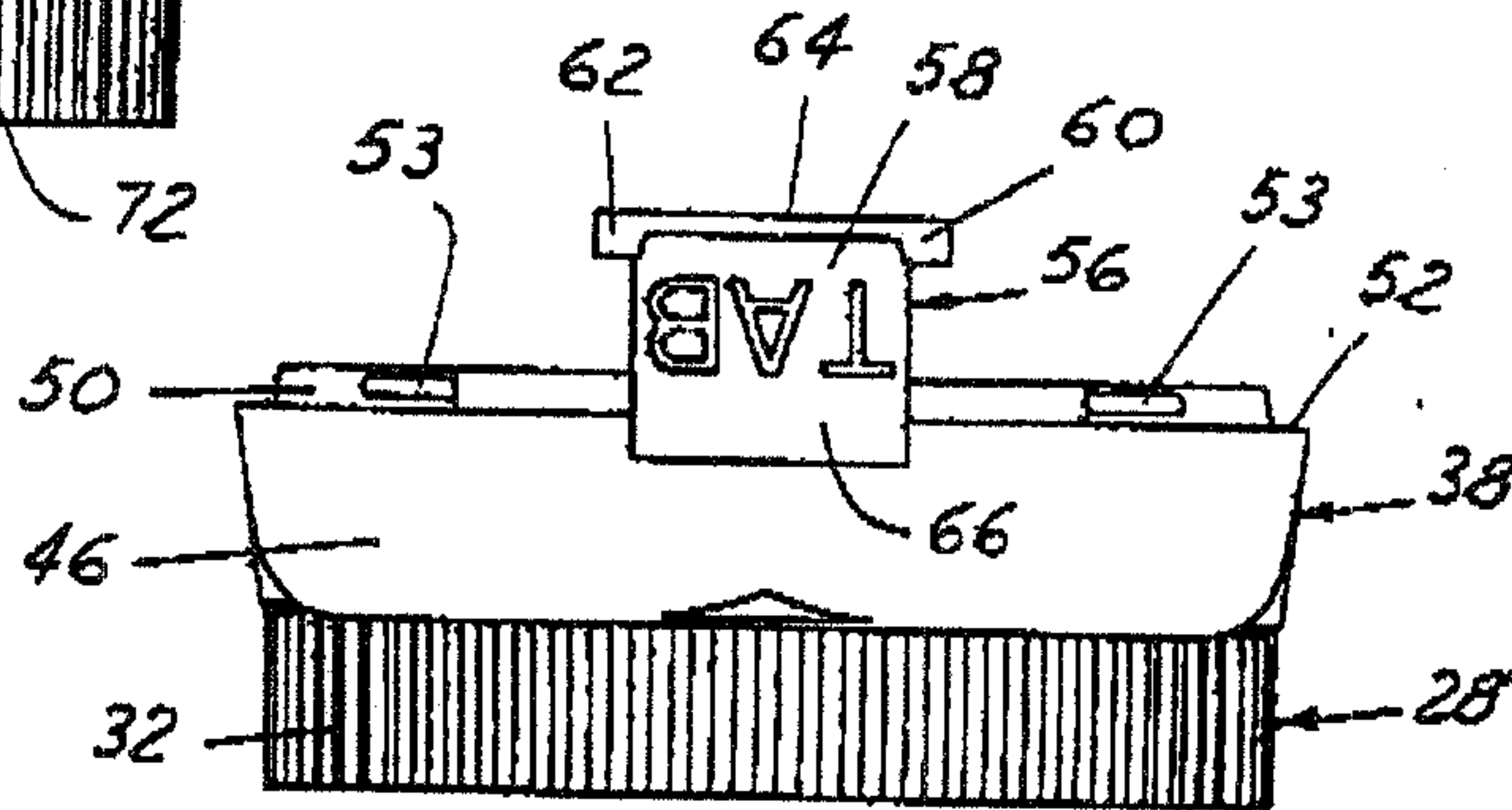

FIG. 5

FIG. 6



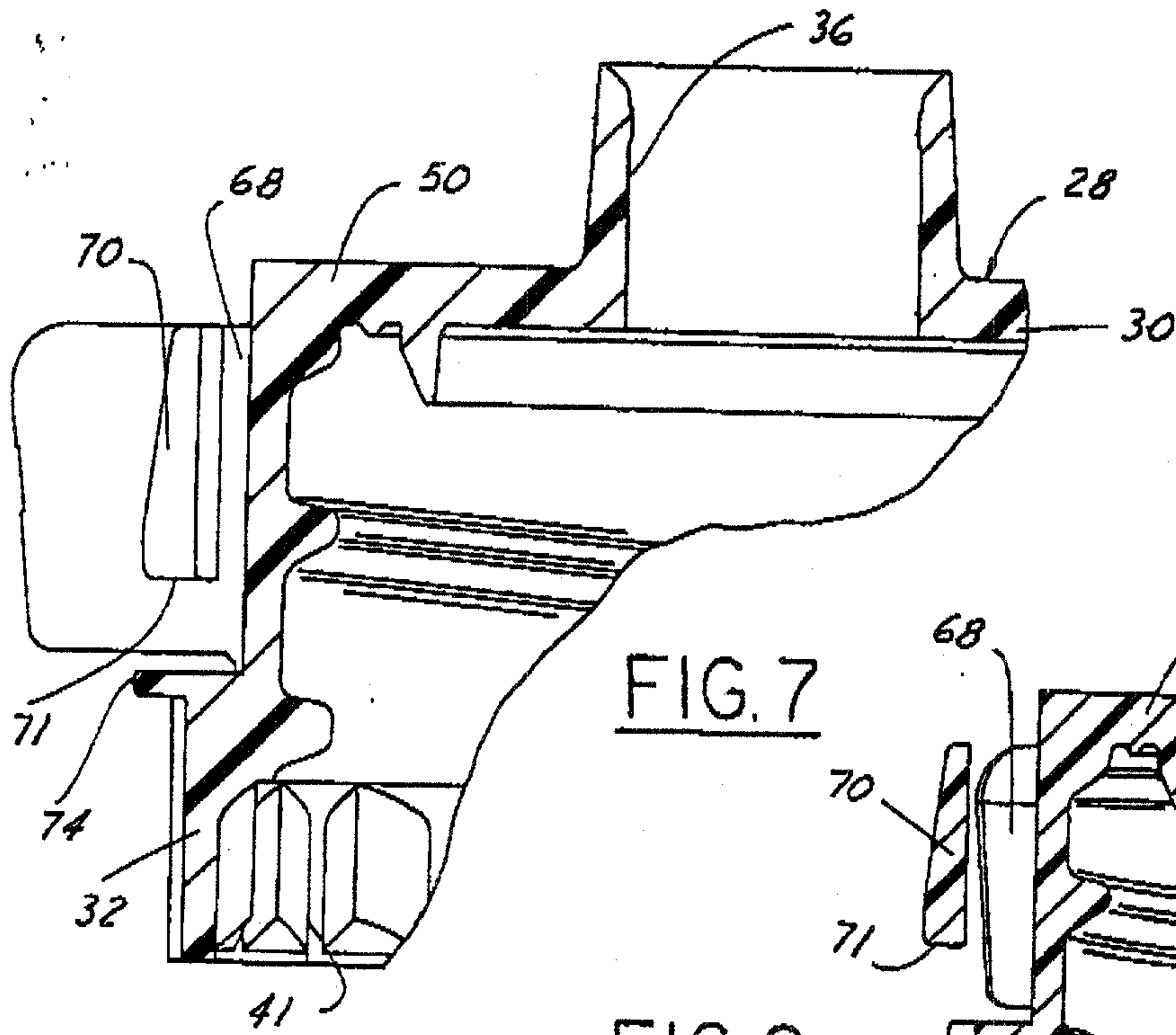

FIG. 7

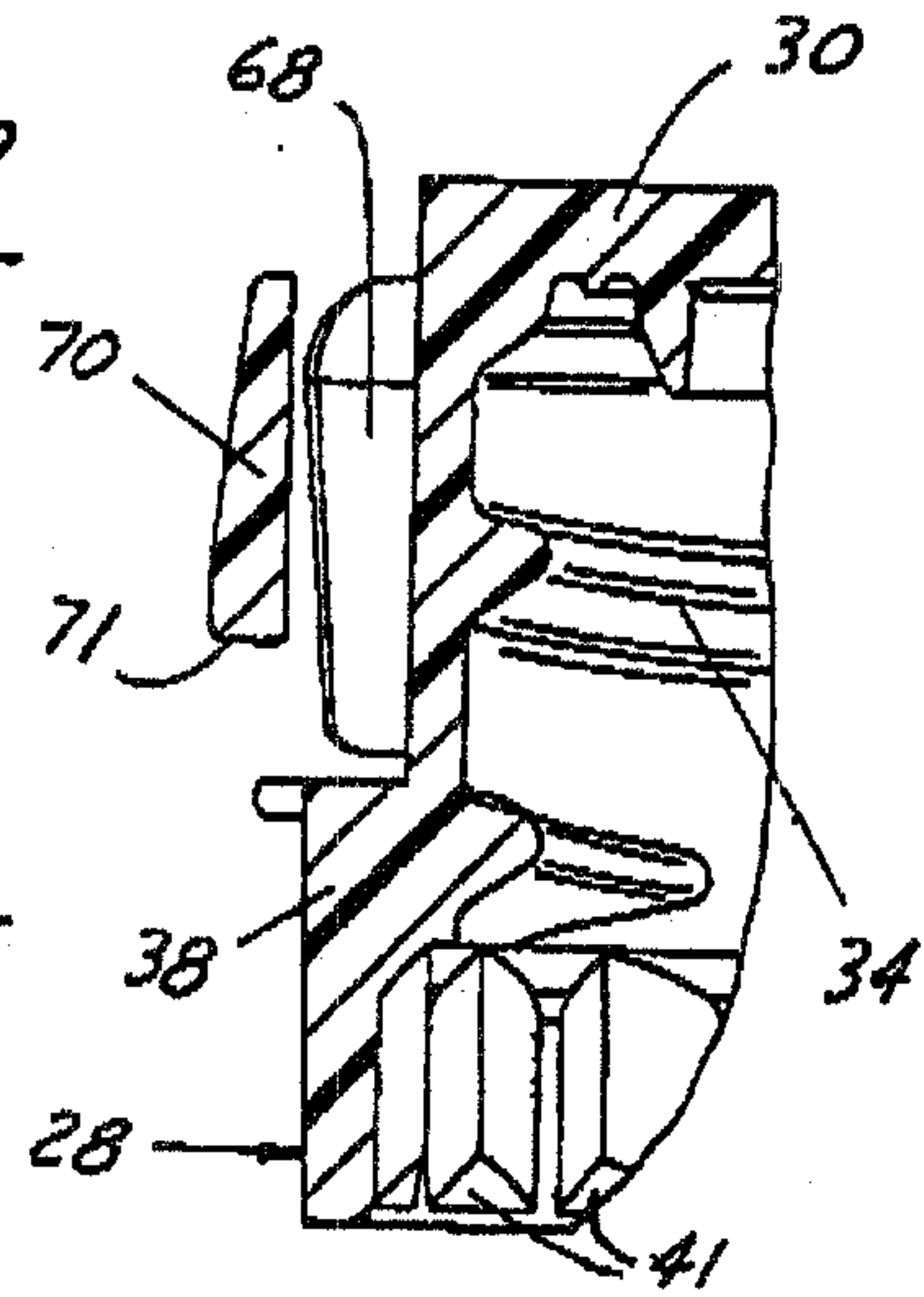

FIG. 8

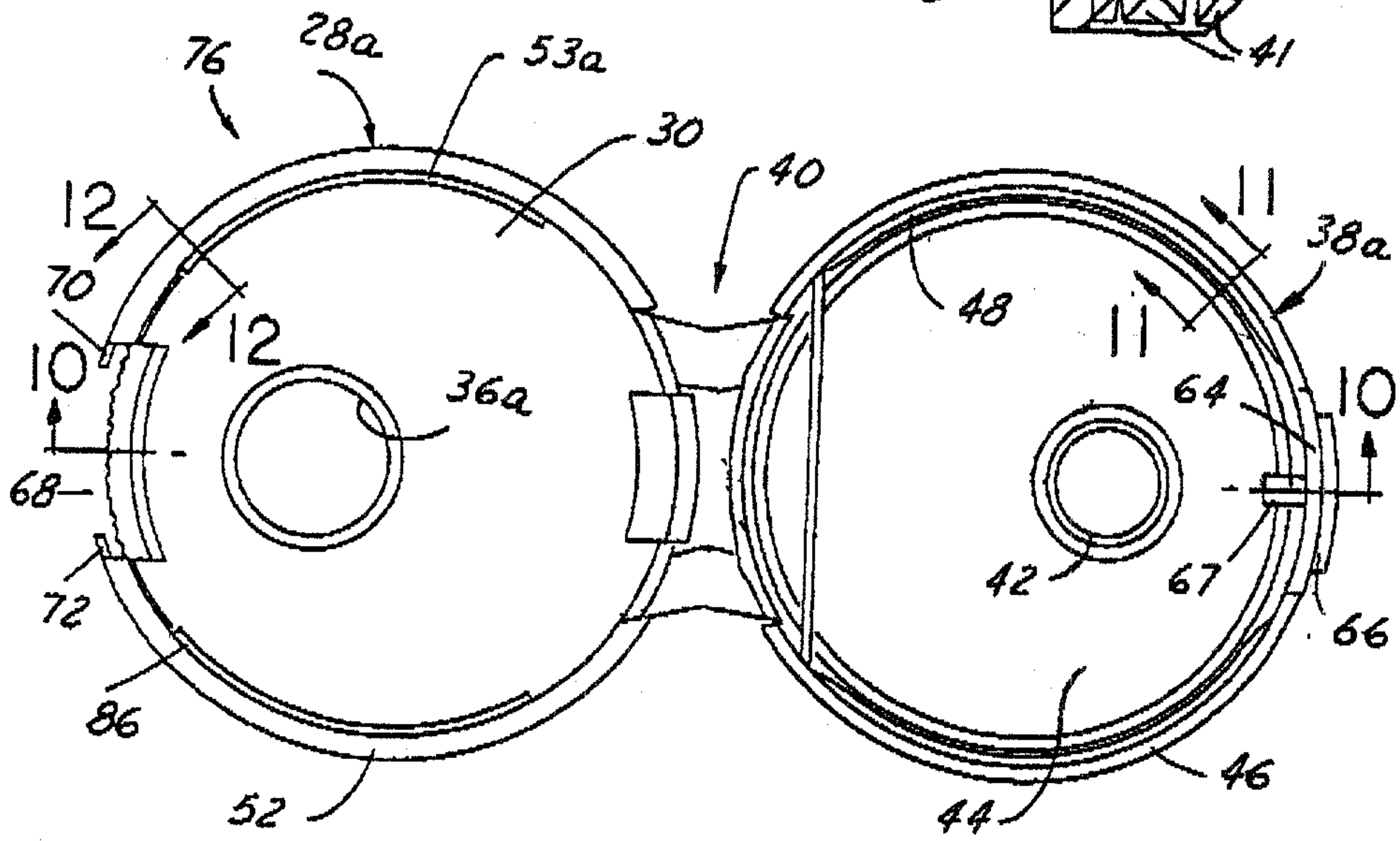

FIG. 9

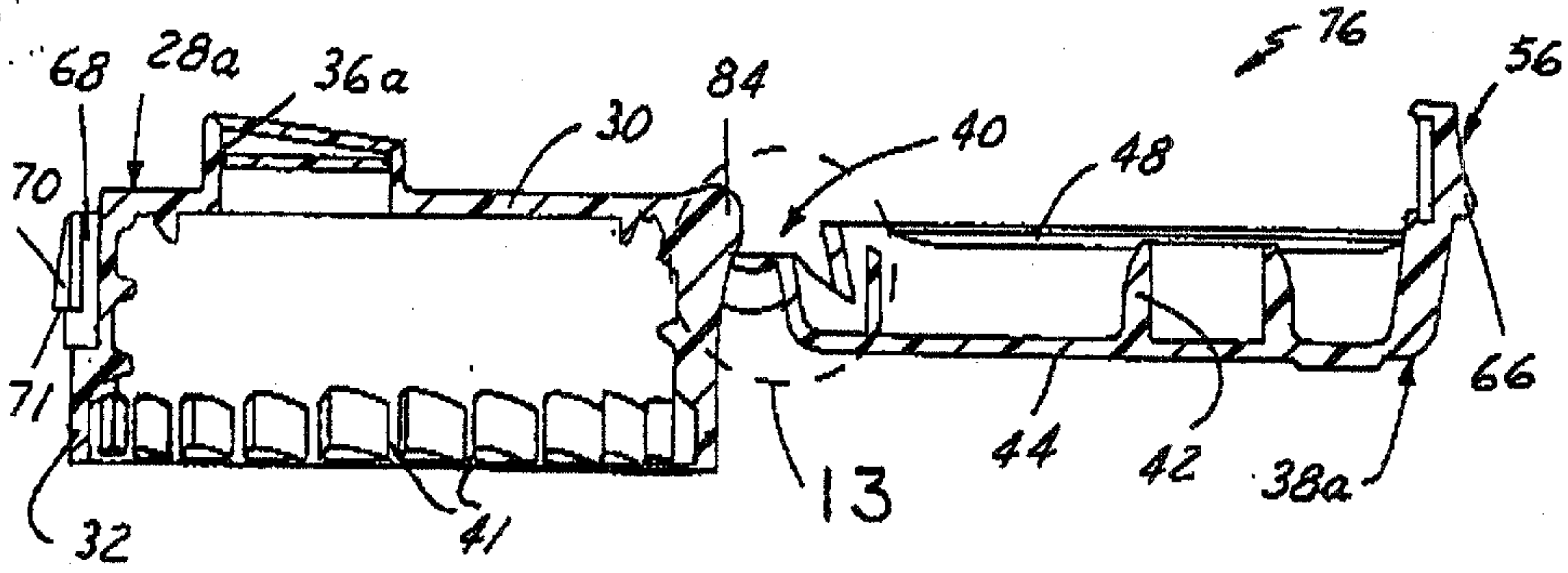

FIG. 10

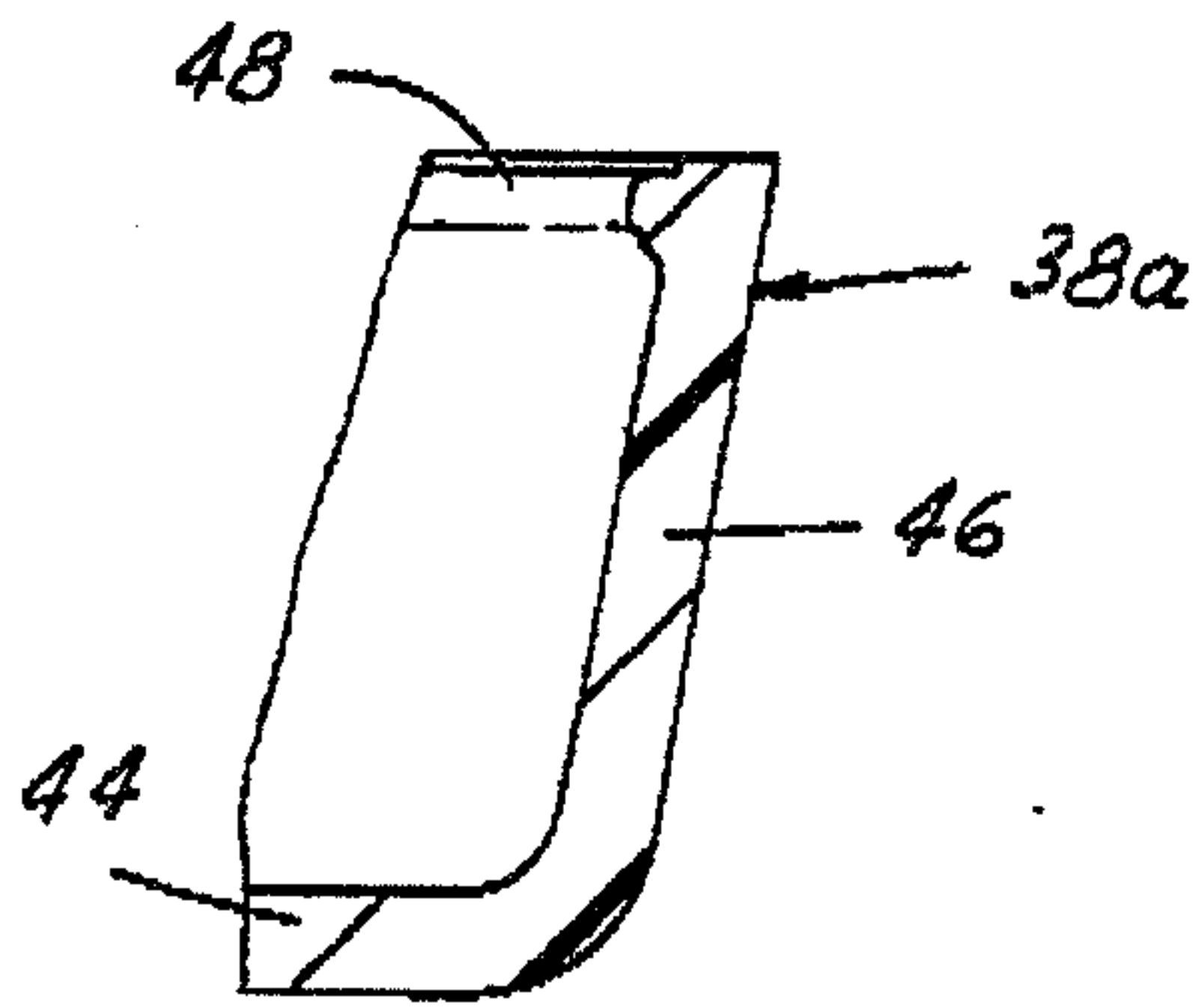

FIG. 11

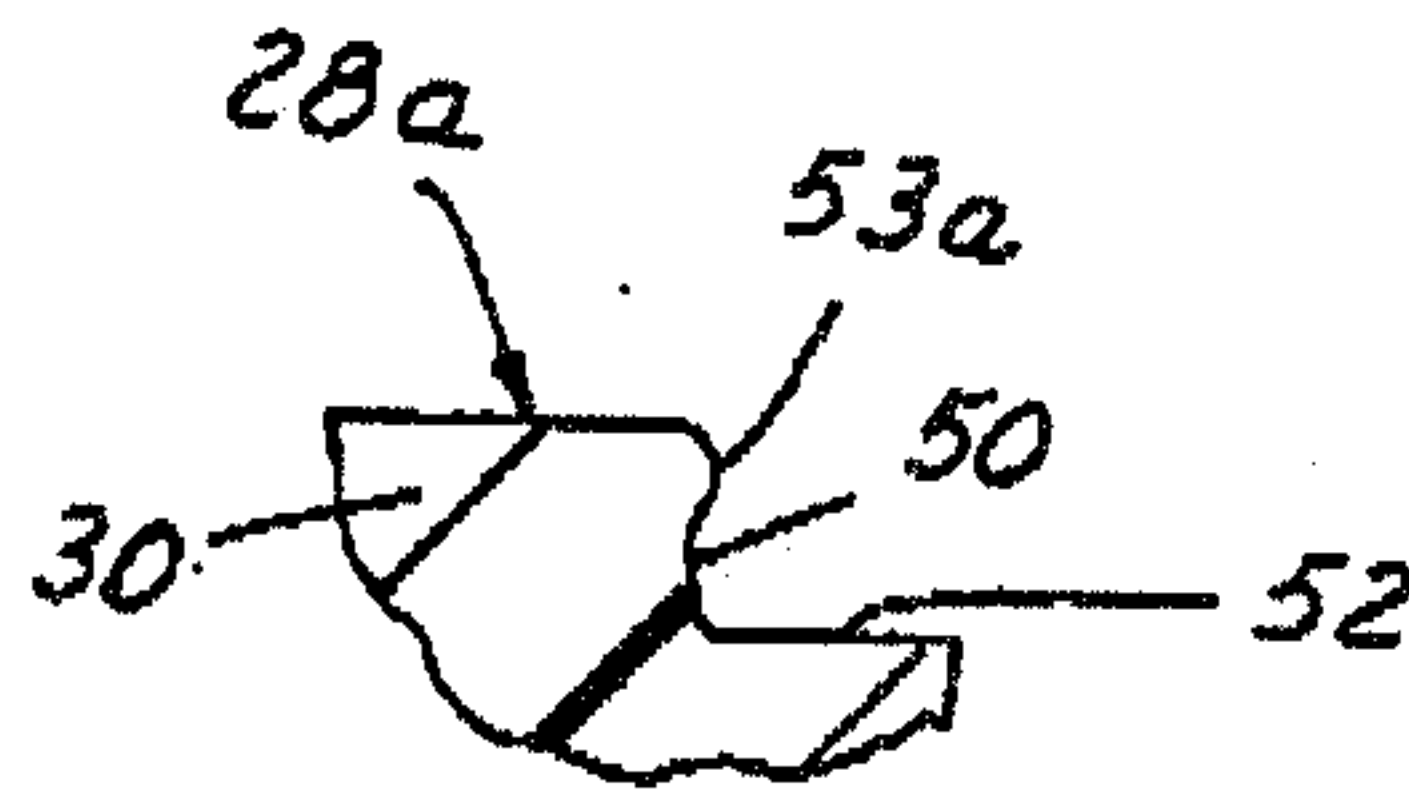

FIG. 12

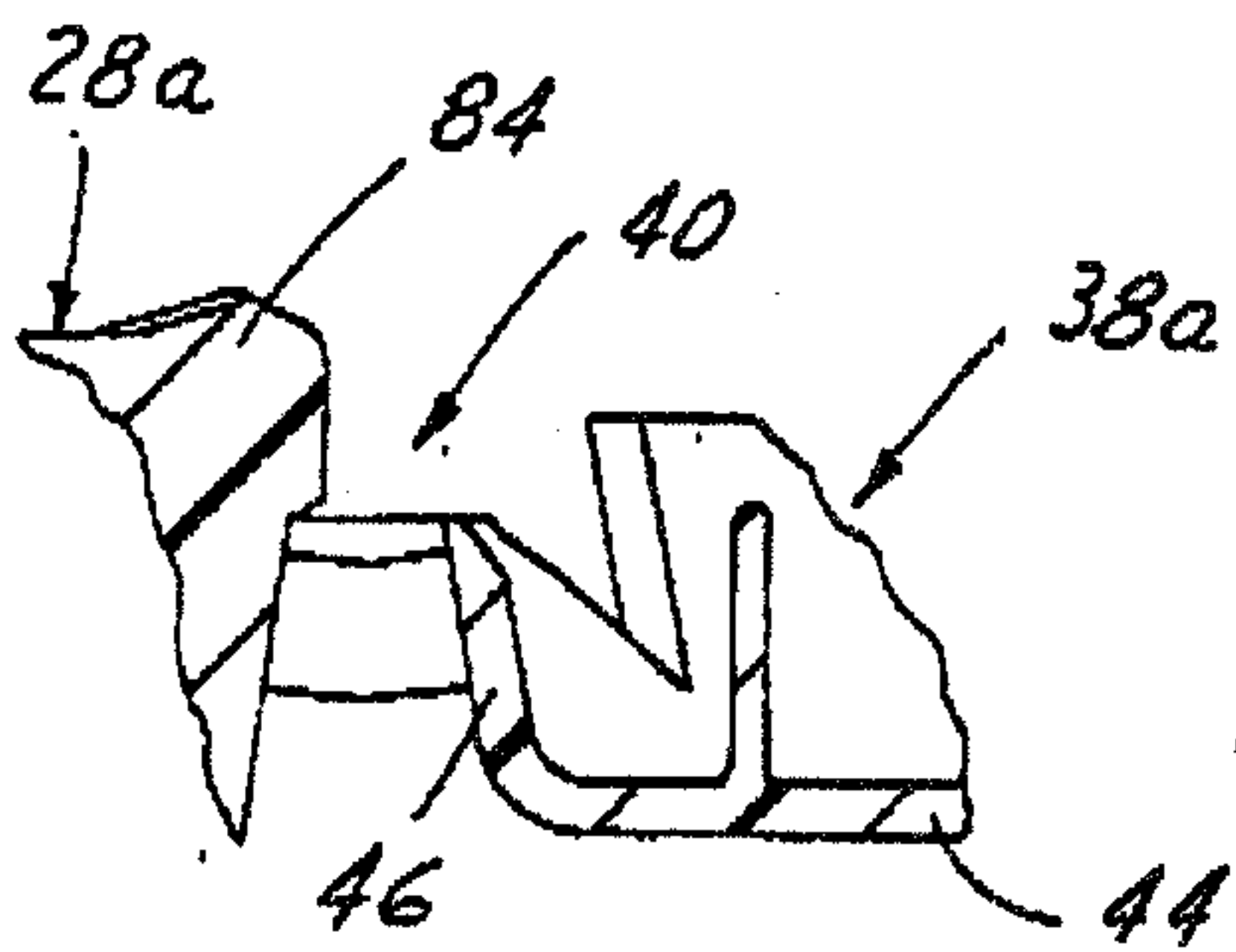
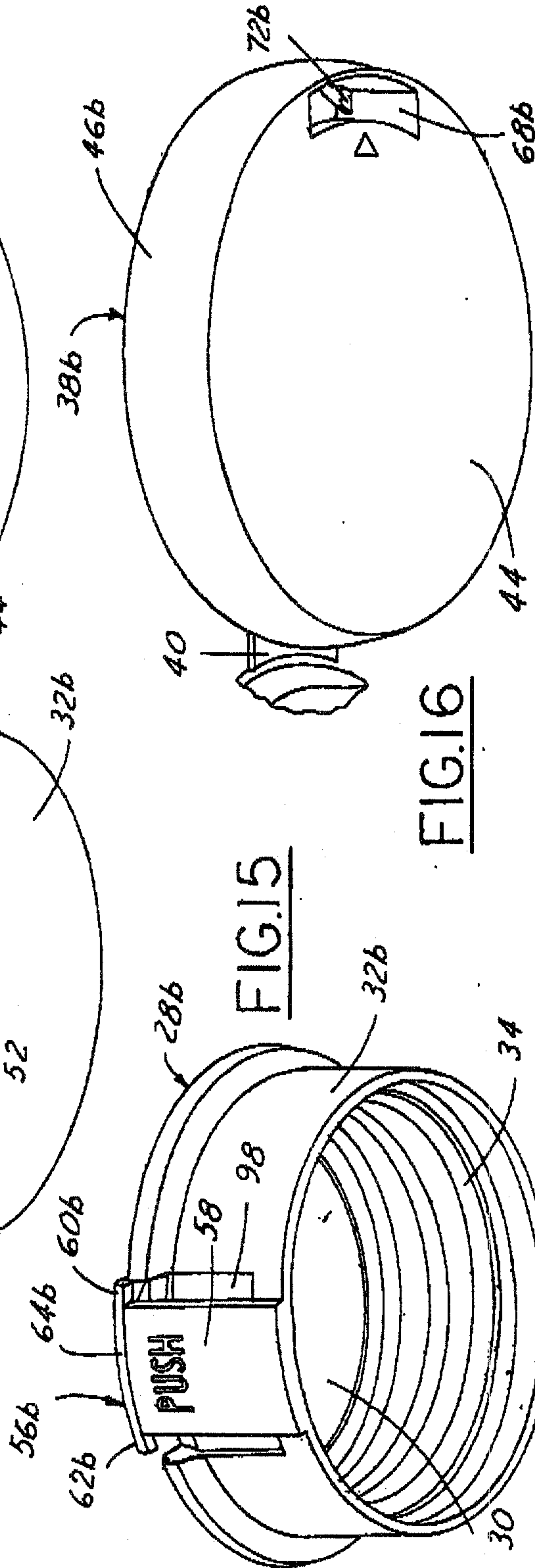
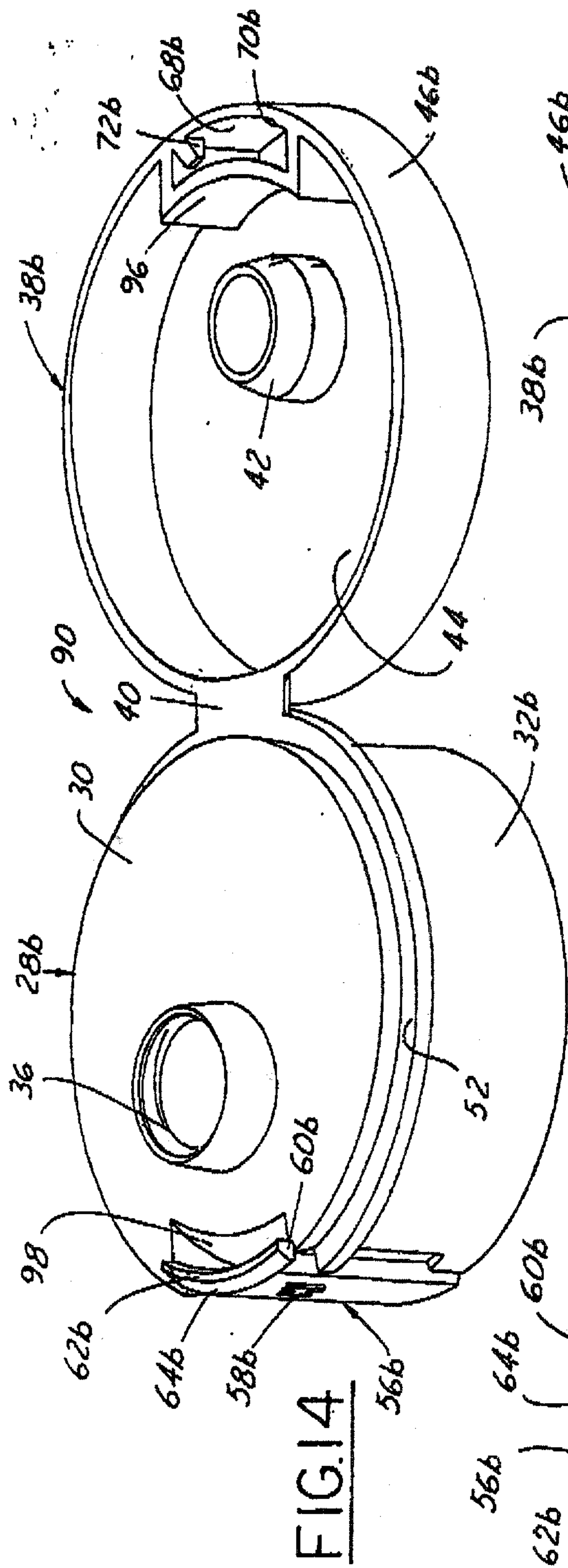

FIG. 13



**FIG. 16**

