

J. RUBIN.  
 INCANDESCENT GAS LAMP.  
 APPLICATION FILED MAY 18, 1910.

969,984.

Patented Sept. 13, 1910.

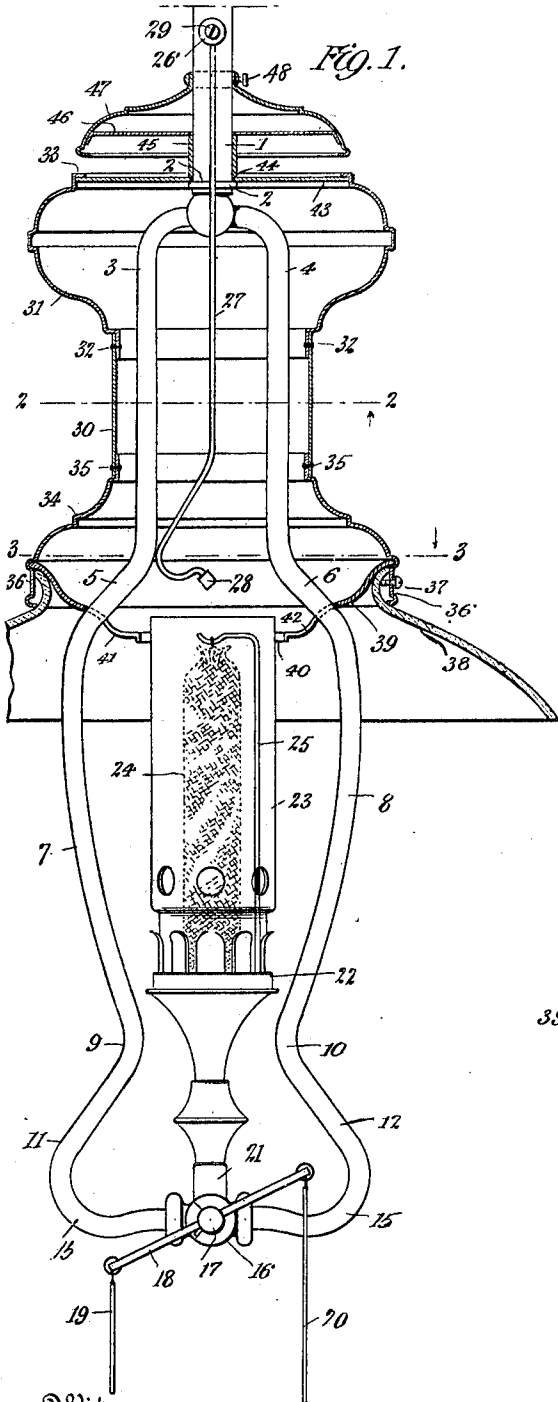

Fig. 2.

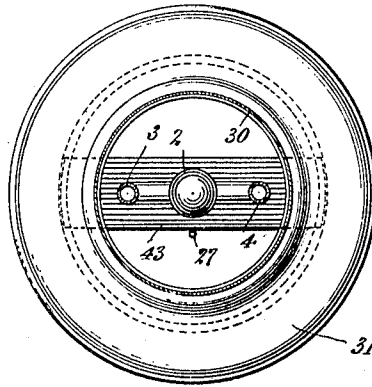
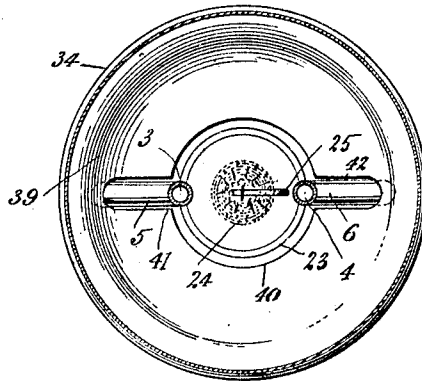

Fig. 3.



Witnesses:  
 Frank H. Ober  
 L. V. Sparks

Inventor  
 Joseph Rubin,  
 By his Attorney  
 Willis Fowler

# UNITED STATES PATENT OFFICE.

JOSEPH RUBIN, OF NEW YORK, N. Y.

INCANDESCENT GAS-LAMP.

969,984.

Specification of Letters Patent. Patented Sept. 13, 1910.

Application filed May 18, 1910. Serial No. 562,046.

To all whom it may concern:

Be it known that I, JOSEPH RUBIN, a subject of the Czar of Russia, residing in the borough of Bronx, New York city, county and State of New York, have invented certain new and useful Improvements in Incandescent Gas-Lamps, of which the following is such a full, clear, and exact description as will enable any one skilled in the art to which it appertains to make and use the same, reference being had to the accompanying drawings, forming part of this specification.

My invention relates to gas lamps in which incandescent mantles are used and the invention has more particular reference to lamps of this class in which the upright Argand burner is employed, though some of the features are applicable to the inverted mantle type of lamp.

I have illustrated a type of my invention in the accompanying drawings, wherein;

Figure 1 is a central vertical section of my improved gas lamp. Fig. 2 is a horizontal sectional view taken on a plane indicated by line 2—2, Fig. 1, and looking upwardly. Fig. 3 is a horizontal sectional view of the lamp, the plane of the section being indicated by line 3—3, Fig. 1, and looking downwardly.

Referring to the drawings in which like numbers of reference designate like parts throughout, 1 is the main gas pipe having a fitting 2 at its lower end and from which extend in opposite directions, the depending pipes 3, and 4, which are suitably spaced from each other and extend for a considerable distance downwardly in a parallel direction, thence bend outwardly at 5 and 6, respectively, and curve inwardly again at 7 and 8, and near their lower ends bend suddenly outwardly at 9 and 10, respectively. The pipes continue on for a short distance in an outward direction at 11 and 12 and are then bent suddenly inwardly at 14 and 15 in a horizontal direction where they both unite with a suitable fitting 16 which is provided with an ordinary valve 17 having a cross arm 18 provided with the usual pull-chains 19 and 20. The fitting 16 carries an ordinary Argand burner 21 on which is mounted a chimney-holder 22 for supporting the vertical glass chimney 23. Upon the burner and within the chimney is mounted an incandescent mantle 24 having the usual supporting device 25.

At a suitable point the main pipe 1 is tapped by the screw valve casing 26 from which depends a detachable pilot light pipe 27 having its burner 28 positioned just above the upper end of the chimney 23, for the usual purpose of lighting the gas from the burner 21 when the valve or key 17 is turned into open position. This valve casing 26 is provided with a screw valve 29 which may be turned by hand to regulate the flow of gas to the pilot light pipe 27 and to cut it off completely when desired.

The depending pipes 3 and 4 are suitably spaced above the chimney so as not to subject them to the direct and intense heat from the chimney and they are curved around the chimney in order to space them therefrom and also to provide the supporting shoulders 5 and 6, respectively, for the inclosing casing, which will be described later on. The inward bends 9 and 10 in the pipes make the same conform somewhat to the general contour of the chimney and the burner, and the corresponding shape of these two pipes cause the same to present a symmetrical and pleasing appearance to the lamp. Either one or the other of the pipes 3 and 4 may be used for supplying the gas to the burner or both of them may be so used and these pipes may be increased or reduced in number, if desired.

The upper part of the depending pipes 3 and 4 are inclosed by a tubular casing within which such part of the pipes are completely housed. This tubular casing comprises a central contracted part 30 and an upper enlarged part 31 which is secured thereto by suitable screws or rivets 32. This enlarged part 31 extends upwardly and outwardly and thence is contracted slightly inwardly at its upper end 33 where it provides an opening for the escape of the gases of combustion coming from the burner. The inclosing casing also comprises a lower part 34 which has a downward and outward flare and is secured to the central part 30 by means of screws 35. At its lower end the casing is provided with a circular shade-holder 36 having set-screws 37 for securing in place a shade 38.

Within the lower end of the tubular casing is mounted an annular shaped reflector 39, the underside of which is convex and through the central opening 40 of which projects the upper end of the chimney 23. This convex surface of the reflector is at a

point somewhat below the shade-holder 36 and in addition to serving as a reflector, this annular part serves to close or contract the flaring end of the casing. The central opening 40 of the annular part 39 is provided with notches or slots 41 and 42 for the reception of the pipes 3 and 4, respectively. The shoulders or outward bends 5 and 6 of the respective pipes extend through the notches 41 and 42 and the closed end of each notch rests directly against the outer side of the pipe passing through it. This serves to support the inclosing casing in its vertical position. The upper end of the inclosing casing is provided with a bracket 43 which is attached to the inside of the upper end of the casing and is mounted on the main pipe 1 by means of a central perforation 44 in the bracket. This bracket serves to keep the casing in its vertical position at its upper end and the bracket is held from rising on the main pipe 1 by means of a sleeve 45 which surrounds the pipe 1 and is interposed between the bracket and the cross piece 46 which is secured to the interior of the deflecting plate 47 which is supported on pipe 1 and at a suitable distance above the upper end of the casing. As the closed ends of the notches 41 and 42, respectively, engage the shoulders 5 and 6 on the depending pipe, and the bracket 43 at the upper end of the casing is held against vertical movement, this serves to secure the casing in firm position upon the pipes.

From the above description, it will be seen that the casing in addition to serving as an intensifier or draft creator, also serves as a housing for the depending pipes and the pilot light pipe, which housing is ornamental, and furthermore the inclosing casing provides a support for the shade-holder at its lower end, likewise a support for the reflector at its lower end.

The deflecting plate 47 has the usual central opening into which takes a set screw 48 for engaging the gas pipe 1 and securing the plate in fixed position. When so fixed this plate through the medium of the cross bar 46 and the sleeve 45 surrounding the gas pipe and the bracket 43 of the casing serves to hold the latter down against the shoulders 5 and 6 on the depending pipes and thus keep the casing in fixed position.

Having thus described my invention what I claim and desire to secure by Letters Patent is:

1. In a gas lamp, the combination of depending pipes and a gas burner mounted on the lower part thereof, a chimney for said burner, a valve controlling the supply of gas to the burner, a casing inclosing the upper part of said pipes and housing the same, an annular supporting plate secured concentrically to the lower end of said casing and engaging said pipes, said plate serving

to support said casing on said pipes and to contract the opening in the lower end of said casing.

2. In a gas lamp, the combination of depending pipes provided with outwardly projecting shoulders or bends, a gas burner mounted on the lower part of said pipes, a chimney for said burner, a valve controlling the supply of gas to the burner, a casing inclosing said pipes and housing the same, an annular supporting plate secured to the lower end of said casing and having the edge of its central opening provided with notches for receiving said pipes and supporting said plate upon the shoulders or bends of said pipes.

3. In a gas lamp, the combination of depending pipes and a gas burner mounted on the lower part thereof, a chimney for said burner, a valve controlling the supply of gas to the burner, a casing inclosing the upper part of said pipes and housing the same, said casing having a contracted part acting as an intensifier or draft pipe, an annular supporting plate secured concentrically to the lower end of said casing and engaging said pipes, said plate serving to support said casing on said pipes and to contract the opening in the lower end of said casing, the upper end of said chimney communicating with the central opening in said plate.

4. In a gas lamp, the combination of depending pipes and a gas burner mounted on the lower part thereof, a chimney for said burner, a valve controlling the supply of gas to the burner, a casing inclosing the upper part of said pipes and housing the same, a shade holder mounted upon the lower end of said casing, an annular supporting plate secured concentrically to the lower end of said casing and engaging said pipes, said plate extending below said shade holder serving to support said casing on said pipes and to contract the opening in the lower end of said casing and also serving as a reflector.

5. In a gas lamp, the combination of depending pipes and a gas burner mounted on the lower part thereof, a chimney for said burner, a valve controlling the supply of gas to the burner, a casing inclosing the upper part of said pipes and housing the same, an annular supporting plate secured concentrically to the lower end of said casing and engaging said pipes, said plate serving to support said casing on said pipes and to contract the opening in the lower end of said casing, a bracket mounted upon the upper part of said pipes and attached to the upper end of said casing to prevent the same from rising.

6. In a gas lamp, the combination of depending pipes and a gas burner mounted on the lower part thereof, a chimney for said

burner, a valve controlling the supply of gas  
to the burner, a casing inclosing the upper  
part of said pipes and housing the same,  
said casing being formed with a contracted  
5 central part and flaring upper and lower  
ends, an annular supporting plate secured  
concentrically to the lower end of said cas-  
ing within the flared part thereof for en-  
gaging said pipes and serving to support  
10 the casing on said pipes and to contract the

opening in the lower flared part of the  
casing.

In testimony whereof, I have hereunto set  
my hand in the presence of the two subscrib-  
ing witnesses.

JOSEPH RUBIN.

Witnesses:

ROBERT F. HENRY,  
WILLIS FOWLER.