

Aug. 5, 1947.

F. K. HIBBARD

2,425,154

ARTIFICIAL HAND CONTROL MECHANISM

Filed Jan. 28, 1946

2 Sheets-Sheet 1

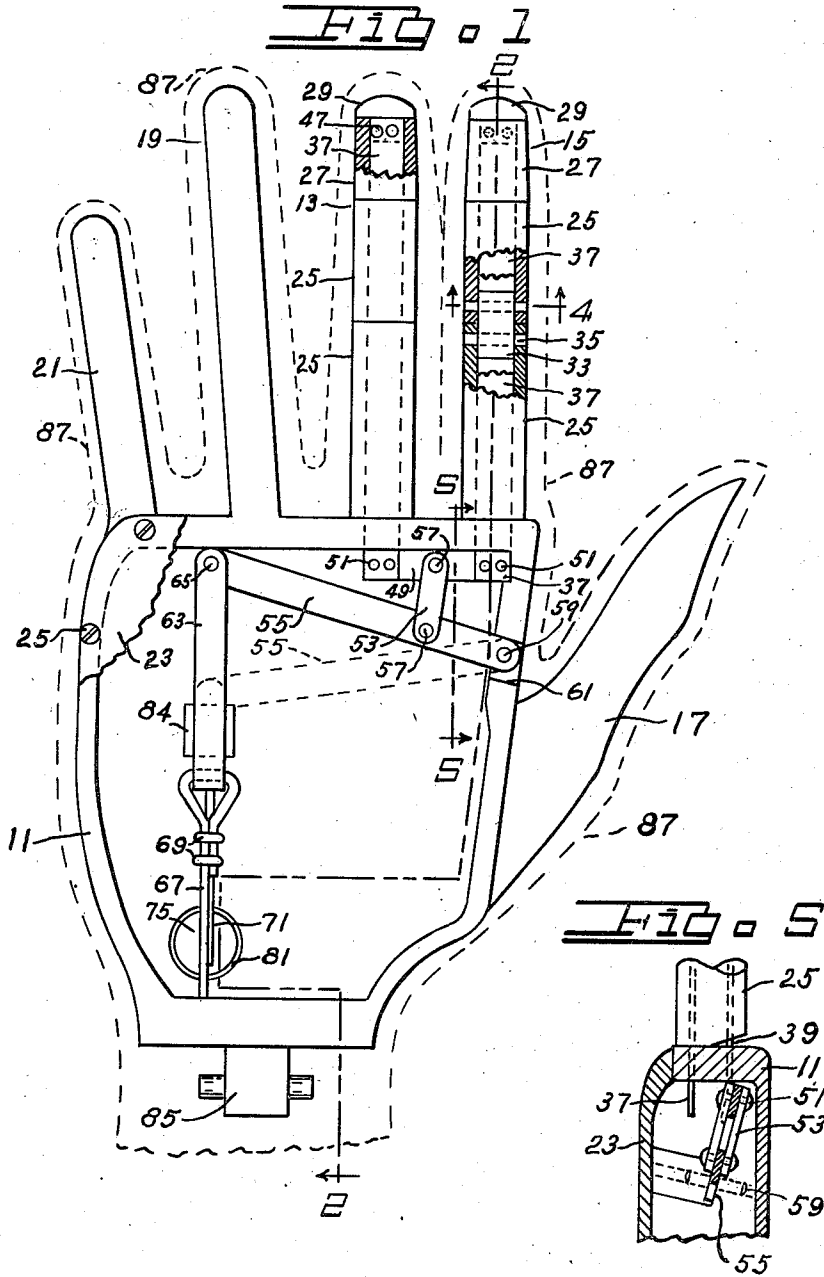

**Fig. 5**

**Fig. 4**

INVENTOR  
*Frank K. Hibbard*  
BY *J. D. Hicks*  
ATTORNEY

Aug. 5, 1947.

F. K. HIBBARD

2,425,154

ARTIFICIAL HAND CONTROL MECHANISM

Filed Jan. 28, 1946

2 Sheets-Sheet 2

Fig 2

Fig 3

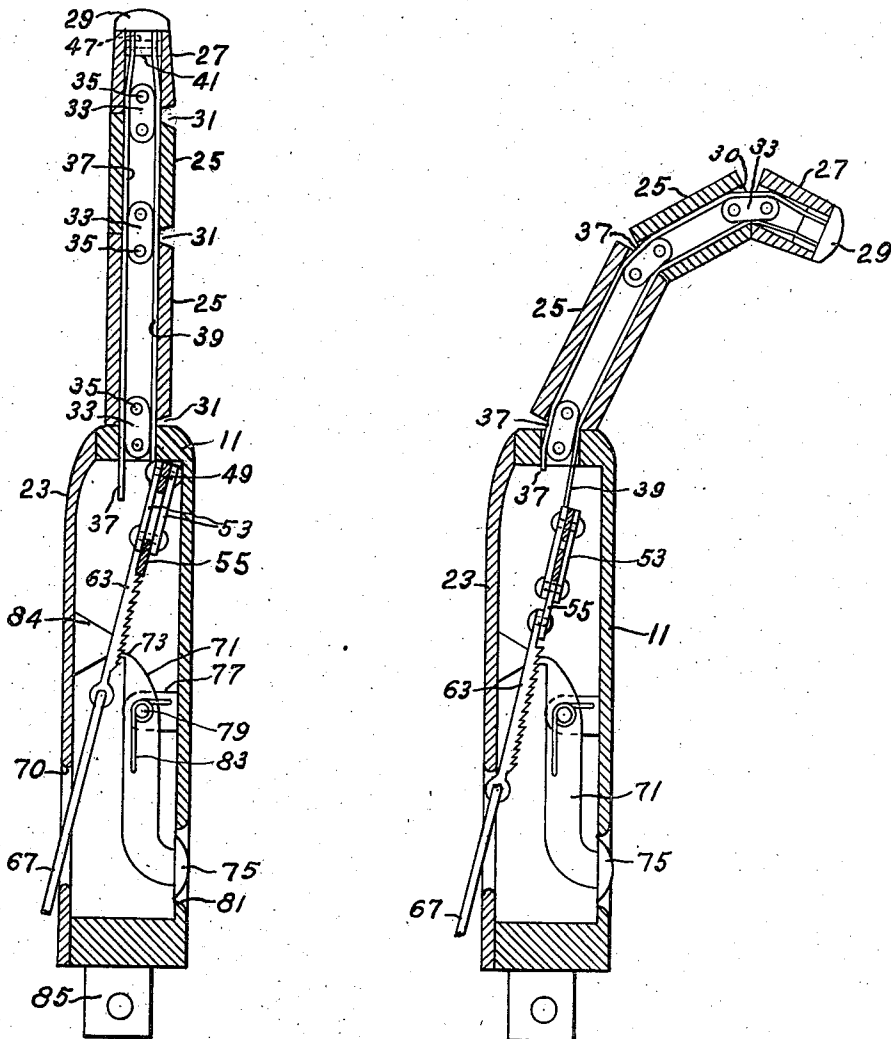
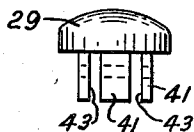

Fig 6



INVENTOR  
*Frank K. Hibbard*

BY *F. D. Hicks*

ATTORNEY

# UNITED STATES PATENT OFFICE

2,425,154

## ARTIFICIAL HAND AND CONTROL MECHANISM

Frank K. Hibbard, Detroit, Mich.

Application January 28, 1946, Serial No. 643,856

5 Claims. (Cl. 3—12)

1

My invention pertains to artificial hands and more particularly to a hand having articulated digital members and control mechanism adapted to be operated to perform functions of a natural hand.

It is an object of my invention to provide an improved artificial hand having movable digital members which may be operated to perform the functions of a natural hand and which is of a strong, simple construction which may be made to closely resemble the appearance of a natural hand.

It is also an object of my invention to provide an artificial hand having movable articulated digital members and control mechanism so that the digital members may be responsive and sensitive for operation by a light force to grip with great power and pressure.

It is a further object of my invention to provide an artificial hand having operative articulated digital members in an improved cooperative relation to rigid digital members.

Also it is an object of my invention to provide an improved actuating mechanism for operating and controlling the movable digital members of an artificial hand.

A further object of my invention is to provide an improved articulated digital member and control connections.

Further objects and advantages are within the scope of my invention, such as relate to the arrangement, operation and function of the related elements of the structure, to various details of construction and to combinations of parts, elements per se, and to economies of manufacture and numerous other features as will be apparent from a consideration of the specification in conjunction with the drawings disclosing specific embodiments of the invention, in which:

Fig. 1 is a plan view of the back of an artificial hand, with portions broken away or represented in dotted lines to show the internal structure, and with the cover skin represented in dotted lines;

Fig. 2 is a sectional view on line 2—2 in Fig. 1; with parts partially broken away and internal parts shown dotted;

Fig. 3 is a similar view showing the articulated digital members flexed to gripping position;

Fig. 4 is a cross-sectional view of one digital member on line 4—4 in Fig. 1 for showing how the knuckle blocks are disposed pivotally in the ends of a phalange member with the flat straightening spring passing on the back thereof and the pull strap passing through the front space;

2

Fig. 5 is a fragmentary sectional view taken on line 5—5 in Fig. 1 for showing how the pull lever is pivotally anchored in the hand housing casting; and

Fig. 6 is a side elevational view showing one of the end cap plugs.

Referring more particularly to the drawings, it will be seen that the artificial hand comprises a hand housing 11 enclosing a hollow space which contains and protects the mechanism for operating a plurality of articulated digital members 13 and 15 which extend from the hand housing in a cooperative relation in the space between rigid digital members. The hand housing 11 is preferably cast of some light weight metal, for which purpose aluminum is preferred, although there are many other metals as well as plastic composition materials which may be utilized. The rigid digital members are also cast integral with the hand housing and although the thumb 17 and the ring finger 19 and the little finger 21 are in this disclosure shown as the rigid members, with the index and middle fingers being the articulated members therebetween, it will be understood that various other arrangements may be made in accordance with the user's requirements. The hand housing 11 is made open at the back and which is closed by a cover plate 23 simulating the back of the hand and which may be installed and secured thereon in any suitable manner, as by screws 25.

Each of the articulated digital members comprises a plurality of phalange members, similar to the bones in the fingers of a human hand, there being two intermediate phalanges 25 and a terminal phalange 27 the distal end of which is closed by a rounded cap 29. Each of the phalanges is made of a suitable light weight metal and provided with a square or rectangular aperture 30 extending axially through. The cooperative abutting ends of these phalanges are suitably conformed so that they abut together snugly with the fingers in a normal straightened position and so that the front sides of the phalanges are shortened to permit the phalanges to be moved or flexed forward to a gripping position, as in Fig. 3. As may be seen in Figs. 2 and 5, this is accomplished by removing some of the metal on the ends toward the front sides so that a clearance space 31 is formed at the front side of the joints between these members and also adjacent the hand housing, when the articulated digital members are straight.

As shown in Figs. 1, 2 and 4, the phalanges are pivotally linked together by means of knuckle

3

blocks 33 the ends of which fit snugly in side fit into the ends of the axial apertures in the phalanges wherein these joint blocks are secured by pivot pins 35 passing transversely through the ends of these blocks and into the phalange members. The front to back dimension of each of these blocks is made smaller than the corresponding dimension of the cross-section of the axial space in each phalange so that front and back spaces 36 are formed. These spaces are formed so that a flat straightening spring 37 may be passed in a free sliding relation through the back spaces and pull strap or tape 39, of bronze or other suitable material, passes freely through the front spaces. The outer end of each terminal phalange is closed by the rounded distal cap 29 which has a plug 41 of suitable form projecting snugly into the outer end of the terminal phalange. As may be seen in the enlarged view Fig. 6, this plug 41 is provided with two slots 43. One slot receives the end of the straightening spring 37 and the other slot receives the outer end of the pull strap 39. Rivets 47 passing through the slotted plug 41 firmly secure the outer ends of the spring and the pull strap, as may be seen in Figs. 1 and 2. From the end where it is attached, the flat straightening spring 37 extends freely through the back spaces in the joints along the backs of the knuckle blocks 33 so that it continuously urges the articulated series of phalange members to a straight aligned relation. The pull strap 39 extends freely along through the front clearance spaces adjacent the knuckle blocks 33 and into the space enclosed in the hand housing 11 for connection with the control mechanism. Because of the construction of the articulated digital members and the disposition of the control elements freely therethrough to connection in the outer ends of the terminal phalanges, a slight force pulling on the pull strap 39 causes such digital members to move to a gripping position with great force.

In the hand housing 11, the ends of the two pull straps 39 are connected to the ends of an equalizer bar 49, as by rivets 51, and from an intermediate position on the equalizer bar a link 53 connects pivotally to an intermediate portion of a pull lever 55. Preferably there are two such links 53, one on each side of the lever 55 and pivotally secured on pivot pins 57. If it is desired to apply equal gripping forces with the two digital members 13 and 15, the pivot pin 57 may be located exactly in the middle of the equalizer bar. But if it is desired to divide the gripping forces unequally between the two fingers, 13 and 15, then the position of the pivot pin 57 in the equalizer bar 49 may be selected accordingly, as will be readily understood.

One end of the pull lever 55 is pivotally anchored on a stationary pivot pin 59 in one side of the hand housing 11. As shown, this may be accomplished by providing a slot 61 in the side of the hand housing adjacent the thumb, wherein the anchor pin 59 may be inserted to secure the end of the pull lever 55. The movable end of the pull lever has a toothed rack 63 pivotally secured thereto, as by a pivot pin 65, and the other end of the rack is secured to a cable 67, the end of the cable passing through an aperture in the rack and being secured in any suitable manner, or by clamps 69 bent firmly thereon. The cable 67 passes out of the hand housing through a back opening 70 and it is positioned and arranged for convenient manipulation by the other hand of

4

the wearer. A pawl 71 is provided having a tooth 73 on one end for engaging and holding the toothed rack 63 in an actuated position. The other end of the pawl lever 71 may form a rounded release button 75. Bearing bracket 77, or a spaced pair, projects in from the palm side of the hand housing 11 for pivotally supporting the pawl lever on a pivot pin 79 with the toothed end adjacent the rack 63 and the release button exposed through an opening 81 in the front side of the housing 11. A pawl tension spring 83 continuously urges the toothed end of the pawl to engage and hold the rack 63 and the articulated digital members in any actuated position. A rack guide 84 is provided projecting in suitably from the inner side of the back cover 23 for guiding the rack 63 as it moves. Fig. 1, the actuated position of the lever 55 is shown dotted. After the wearer of the artificial hand has performed the desired task with the hand, he may conveniently release it by a light touch on the release button 75. The straightening springs 37 will then straighten out the articulated digital members and the control mechanism resumes the normal position ready for the next operation, as shown in full lines in Fig. 1.

The wrist portion of the artificial hand is shown terminated in a coupling 85 which may be any conventional connection means for securing the hand to the stump socket on the forearm or to an artificial arm, in a usual manner. The entire hand is preferably covered by a soft covering 87, represented dotted in Fig. 1, which simulates natural skin in color and texture.

Because of the arrangement of the pull tapes 39 secured in the ends of the articulated digital members, these are very responsive and in combination with the pull lever and the equalizer arrangement provides a hand which applies a very strong grip responsive to a light force, which is simple and rugged in construction and easy to make and maintain in addition to being adaptable to a very lifelike and natural appearance.

It is apparent that within the scope of my invention modifications and different arrangements may be made other than herein disclosed, and the present disclosure is illustrative merely, the invention comprehending variations thereof.

What is claimed is:

1. In combination in an artificial hand, a hand housing enclosing a hollow space, a plurality of articulated digital members extending pivotally from said hand housing, each of said articulated digital members comprising a plurality of phalanges similar to the bones in a human finger, an aperture of substantially rectangular cross-section extending axially through each of the intermediate phalanges and into the terminal phalanges, knuckle blocks extending into adjacent ends of the apertured phalanges, the side-to-side dimension of said blocks fitting snugly into the apertures and the front-to-back dimension of each block being smaller than the corresponding dimension of the aperture to provide front and back spaces for operative members, the hand housing being apertured suitably to receive the end of the block link from the adjacent end of the adjacent phalange, pivot pins extending sidewise through the ends of said knuckle blocks into the sidewalls of the apertures for pivotally joining phalanges together in articulated relation from the hand housing, a straightening spring of flat ribbon form secured into the end of each terminal phalange and extending slidably through the back spaces and into the aperture in the

5

hand housing for straightening each digital member, a pull strap secured into the outer end of each of the terminal phalanges and extending slidably through the front spaces in the phalanges into the hand housing, and actuation means for pulling and holding said pull straps for flexing and gripping articulated digital members.

2. An artificial hand in accordance with claim 1 and further characterized by said actuation means comprising an equalizer bar secured to the ends of the pull straps in the hand housing, a pull lever, a stationary pivot in the hand housing for securing one end of the lever pivotally, a toothed rack extending from the free end of the pull lever, a pull cable extending from the rack and passing out of the hand housing for convenient operation, a pawl lever having a tooth on one end for engaging and holding said rack in any actuated position, means pivotally mounting said pawl lever in said hand housing for engaging the tooth with said rack and exposing the other end of the pawl lever for convenient access to apply a releasing pressure, and resilient biasing means continuously urging the toothed end of the pawl lever to engage the rack.

3. In combination in an artificial hand, a hand housing enclosing a hollow space, a thumb member extending rigidly from said palm frame, two digital members corresponding to the little finger and the ring finger extending rigidly from said hand housing two articulated digital members extending from said hand housing corresponding to the index finger and the middle finger, each of the articulated digital members having a pull strap secured in the outer end and passing freely through each such member into the hollow space in the hand housing, an equalizer bar in said housing, means securing the two pull straps to the ends of the equalizer bar, a pull lever in said housing, a stationary anchor pin pivotally holding one end of said lever, a pull cable extending from the other end of said pull lever, and link means pivotally connecting from the central portion of the equalizer bar to an intermediate point on the pull lever for actuating and gripping the articulated digital members with great force when a light pull is applied on the pull cable, and resilient bias straightening means continuously urging said articulated digital members to straightened positions.

4. In combination in an artificial hand, a hand housing enclosing a hollow space, a plurality of digital members extending rigidly from said hand housing, two articulated digital members extending from said housing in cooperative rela-

6

tion to the rigid digital members, each of the articulated members having a pull strap secured in the outer end and passing freely through into the space enclosed in the hand housing, an equalizer bar secured to the ends of the pull straps in the hand housing, a pull lever, a stationary pivot securing one end of the lever pivotally in one side of the hand housing, a toothed rack extending from the free end of the pull lever, a pull cable extending from the rack and passing out of the hand housing for convenient operation, and conveniently releasable pawl means for securing said toothed rack and holding the articulated digital members in any gripping position.

5. An articulated digital member for attachment to an artificial hand comprising, two intermediate phalanges, a terminal phalange, an aperture of substantially rectangular cross-section extending through each of the intermediate phalanges and through the terminal phalange, link blocks extending into adjacent ends of the apertured phalanges, the side-to-side dimension of said blocks fitting snugly into the apertures and the front-to-back dimension of each block being smaller than the corresponding dimension of the aperture to provide front and back spaces for operative members, pivot pins extending side-wise through the ends of said link blocks into the sidewalls of the apertures for pivotally joining the phalanges together in articulated relation, a rounded end cap on the outer end of the terminal phalange, said cap having a plug fitting into the outer end of the terminal phalange whereon it is mounted, a pair of slots in spaced relation in said plug and opening into the aperture in the terminal phalange, a straightening spring of flat ribbon form secured into one of the slots in the plug in the end of the terminal phalange and extending slidably through the back spaces for straightening each digital member, a pull strap secured into the other slot in the plug in terminal phalange and extending slidably through the front spaces in the phalange for connection with operation means.

FRANK K. HIBBARD.

## REFERENCES CITED

The following references are of record in the file of this patent:

## UNITED STATES PATENTS

Number	Name	Date
809,797	Grogan	Jan. 9, 1906
2,301,009	Becket	Nov. 3, 1942
51,238	Snellerberg	Nov. 28, 1865
450,476	Sparham	Apr. 14, 1891

---

**Certificate of Correction**

Patent No. 2,425,154.

August 5, 1947.

FRANK K. HIBBARD

It is hereby certified that error appears in the printed specification of the above numbered patent requiring correction as follows: Column 5, line 7, claim 1, after the word "gripping" insert *the*; and that the said Letters Patent should be read with this correction therein that the same may conform to the record of the case in the Patent Office.

Signed and sealed this 7th day of October, A. D. 1947.

[SEAL]

THOMAS F. MURPHY,  
*Assistant Commissioner of Patents.*