

(12) **United States Design Patent** (10) **Patent No.:** **US D917,378 S**
Kunkel et al. (45) **Date of Patent:** **** Apr. 27, 2021**

(54) **TIRE FOR AUTOMOBILE**

DESCRIPTION

(71) Applicant: **SUMITOMO RUBBER INDUSTRIES, LTD.**, Kobe (JP)
 (72) Inventors: **Daniel Kunkel**, Hanau (DE); **Peter Glasner**, Hanau (DE); **Jaap Leendertse**, Hanau (DE)
 (73) Assignee: **SUMITOMO RUBBER INDUSTRIES, LTD.**, Kobe (JP)
 (**) Term: **15 Years**
 (21) Appl. No.: **29/710,623**
 (22) Filed: **Oct. 24, 2019**
 (30) **Foreign Application Priority Data**
 Sep. 10, 2019 (JP) 2019-020236
 (51) **LOC (13) CL.** **12-15**
 (52) **U.S. CL.**
 USPC **D12/605**
 (58) **Field of Classification Search**
 USPC D12/604, 605
 (Continued)

(56) **References Cited**
 U.S. PATENT DOCUMENTS
 D550,150 S * 9/2007 Shondel D12/605
 D569,336 S * 5/2008 Onoe D12/605
 (Continued)

Primary Examiner — Michelle E. Wilson
Assistant Examiner — Clese Moore, Jr.
 (74) *Attorney, Agent, or Firm* — Birch, Stewart, Kolasch & Birch, LLP

(57) **CLAIM**
 The ornamental design for a tire for automobile, as shown and described.

FIG. 1 is a front view of a tire for automobile showing our new design;
 FIG. 2 is a rear view thereof;
 FIG. 3 is a top plan view thereof;
 FIG. 4 is a bottom plan view thereof;
 FIG. 5 is a right side view thereof;
 FIG. 6 is a left side view thereof;
 FIG. 7 is a partial enlarged view of portion 7A-7B thereof;
 FIG. 8 is a partial enlarged view of portion 8A-8B thereof;
 FIG. 9 is a partial enlarged view of portion 9A-9B thereof;
 FIG. 10 is a partial enlarged view of portion 10A-10B of FIG. 7;
 FIG. 11 is a partial enlarged view of portion 11A-11B of FIG. 7;
 FIG. 12 is a partial enlarged view of portion 12A-12B of FIG. 8;
 FIG. 13 is an end elevational view taken along line 13-13 of FIG. 10;
 FIG. 14 is an end elevational view taken along line 14-14 of FIG. 10;
 FIG. 15 is an end elevational view taken along line 15-15 of FIG. 11;
 FIG. 16 is a partial enlarged view of portion 16-16 of FIG. 13;
 FIG. 17 is a partial enlarged view of portion 17-17 of FIG. 13;
 FIG. 18 is a partial enlarged view of portion 18-18 of FIG. 14;
 FIG. 19 is a partial enlarged view of portion 19-19 of FIG. 14;
 FIG. 20 is a partial enlarged view of portion 20-20 of FIG. 15;
 FIG. 21 is an enlarged end elevational view taken along line 21-21 of FIG. 12; and,
 FIG. 22 is an end elevational view taken along line 22-22 of FIG. 9.
 The portions of the drawings illustrated in broken lines are directed to the environment of the design and form no part of the claimed design.

1 Claim, 22 Drawing Sheets

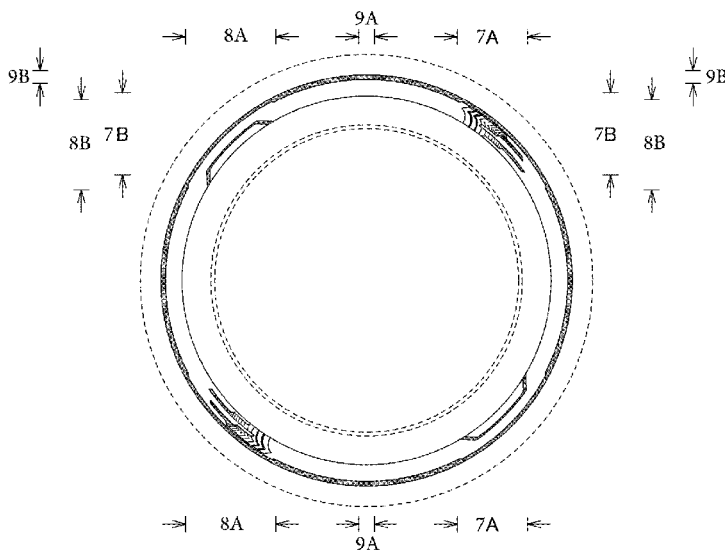

(58) **Field of Classification Search**

CPC B60C 13/00; B60C 1/00

See application file for complete search history.

(56) **References Cited**

U.S. PATENT DOCUMENTS

D569,792	S	*	5/2008	Holden	D12/605
D590,332	S	*	4/2009	Sato	D12/605
D593,486	S	*	6/2009	Yonetsu	D12/605
D593,939	S	*	6/2009	Maxwell	D12/605
D596,118	S	*	7/2009	Frappart	D12/605
D632,641	S	*	2/2011	Sato	D12/605
D640,187	S	*	6/2011	Fontaine	D12/605
D655,671	S	*	3/2012	Yasunaga	D12/605
D662,877	S	*	7/2012	Arrant	D12/605
D668,210	S	*	10/2012	Sato	D12/605
D676,805	S	*	2/2013	Iwabuchi	D12/605
D684,109	S	*	6/2013	Iwabuchi	D12/605
D709,025	S	*	7/2014	Takahashi	D12/605
D750,555	S	*	3/2016	Iwabuchi	D12/605
D754,063	S	*	4/2016	Iwabuchi	D12/605
D769,807	S	*	10/2016	Ishikawa	D12/605
D791,693	S	*	7/2017	Iwabuchi	D12/605
D795,178	S	*	8/2017	Maxwell	D12/605
D800,643	S	*	10/2017	Scheifele	D12/605
D803,149	S	*	11/2017	Ishikawa	D12/605
D847,737	S	*	5/2019	Yasunaga	D12/605
D851,030	S	*	6/2019	Nagase	D12/605
D856,915	S	*	8/2019	Nagase	D12/605
D858,431	S	*	9/2019	Yamaoka	D12/605

* cited by examiner

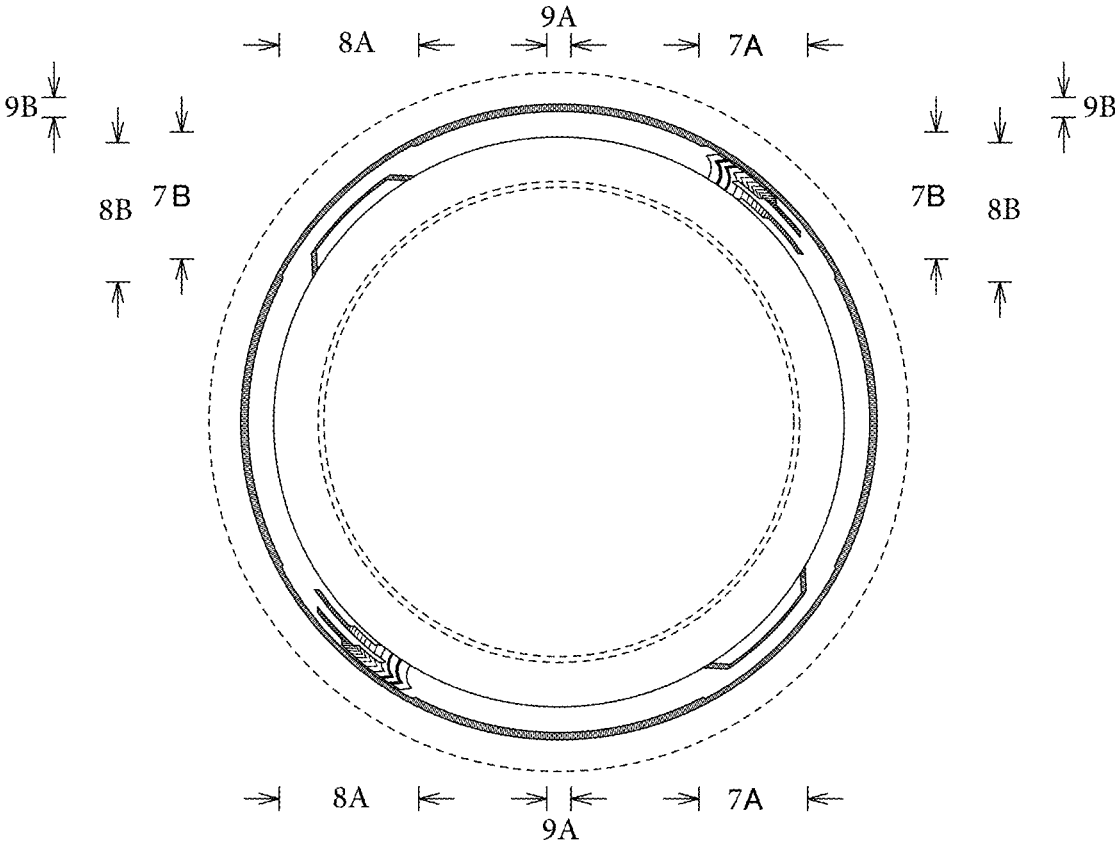

FIG. 1

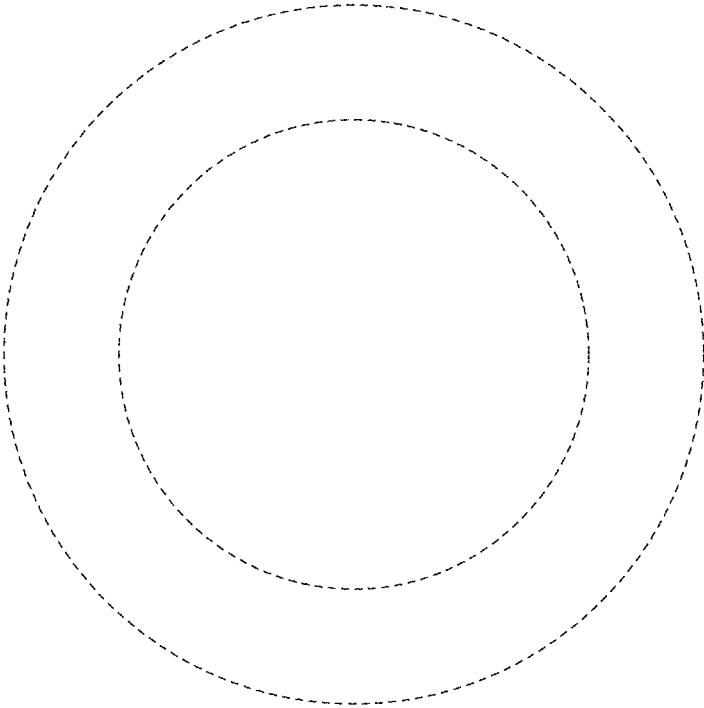

FIG. 2



FIG. 3



FIG. 4

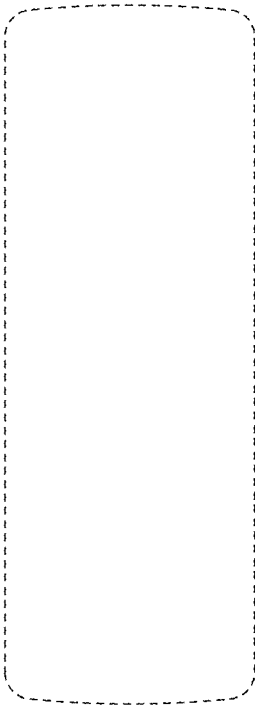

FIG. 5

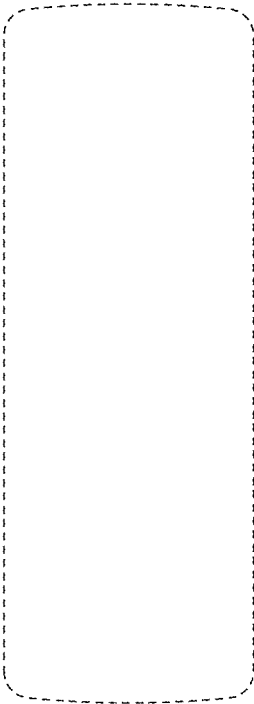

FIG. 6

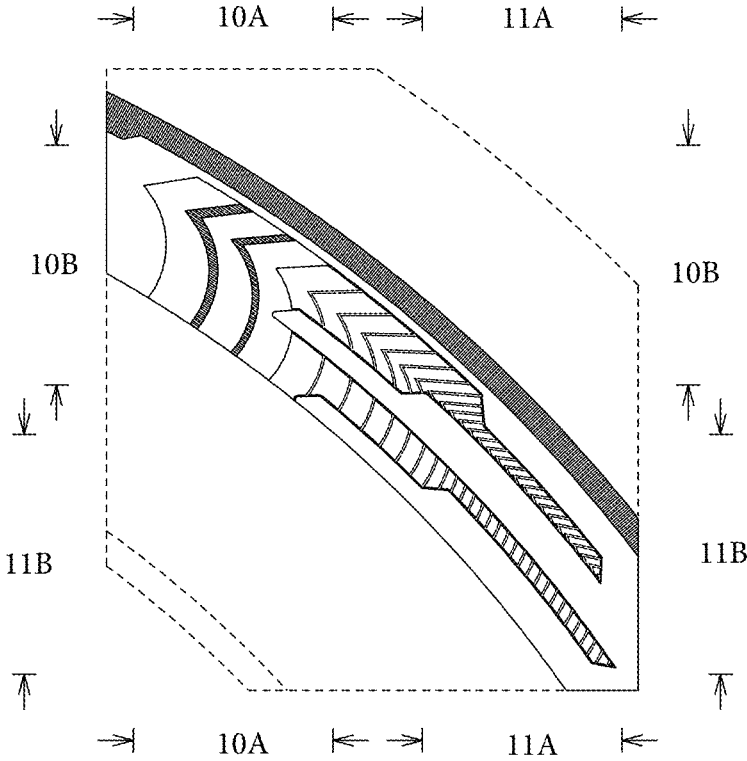

FIG. 7

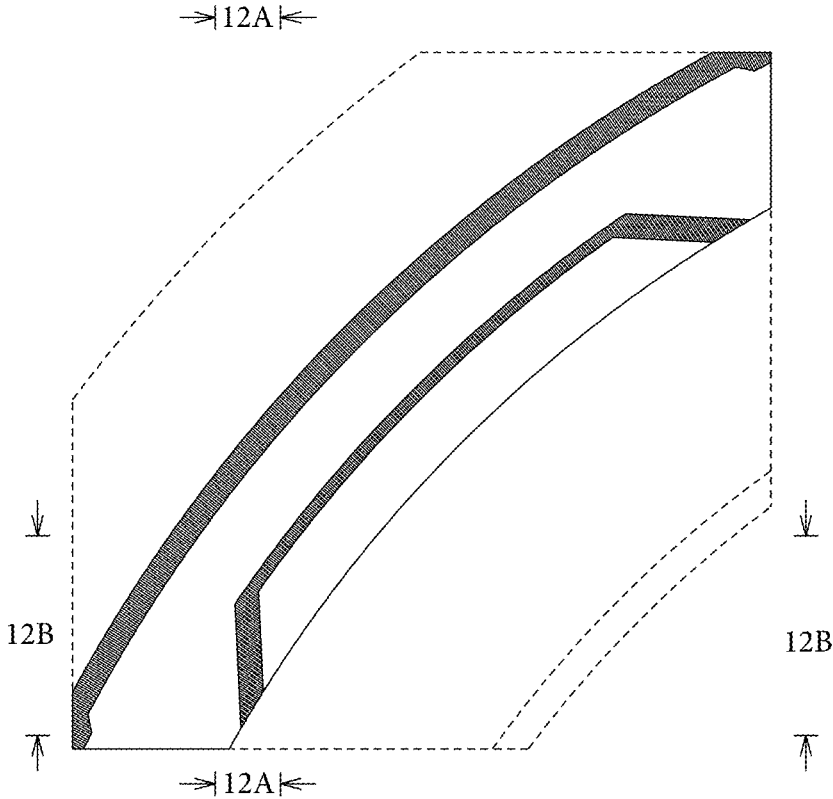

FIG. 8

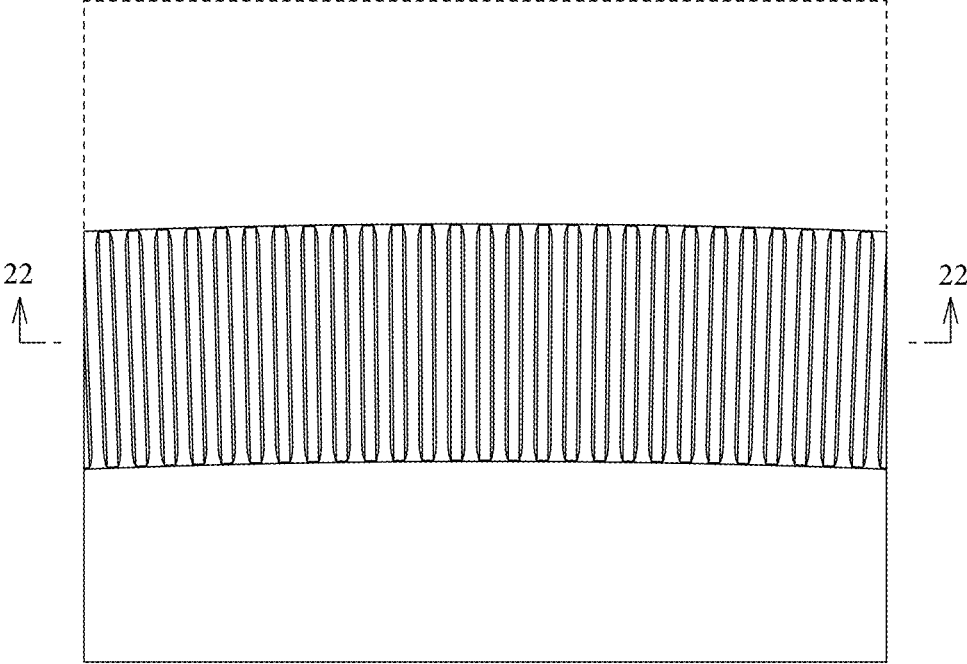

FIG. 9

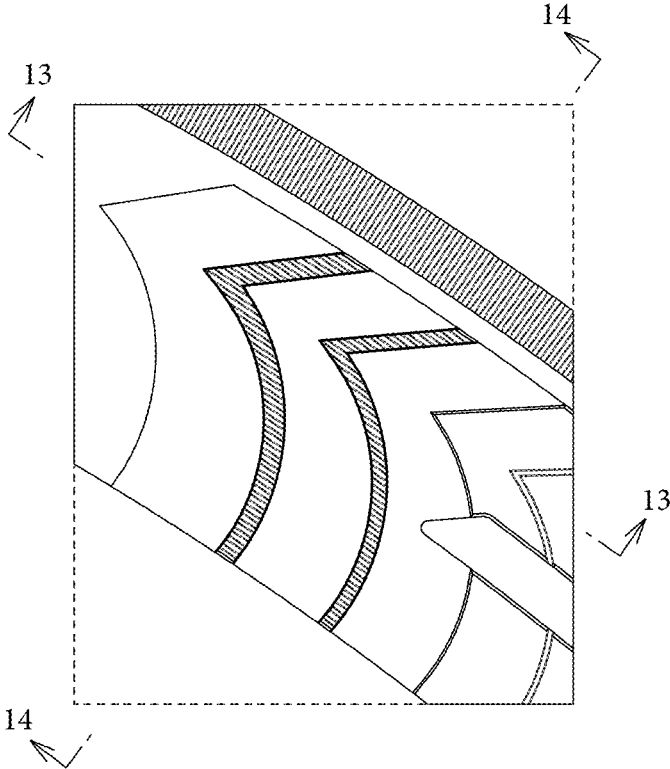

FIG. 10

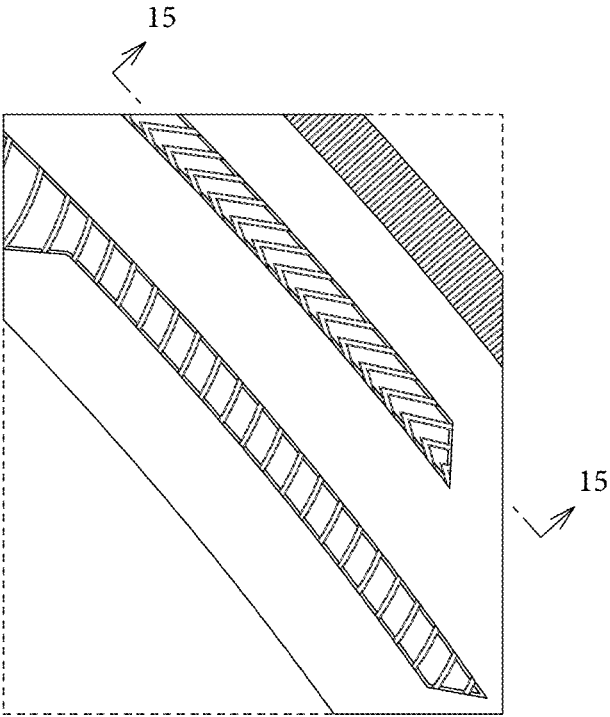

FIG. 11

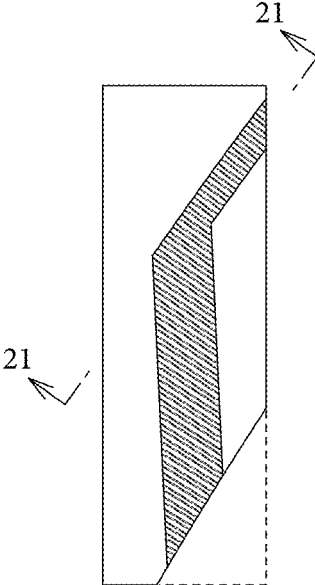

FIG. 12

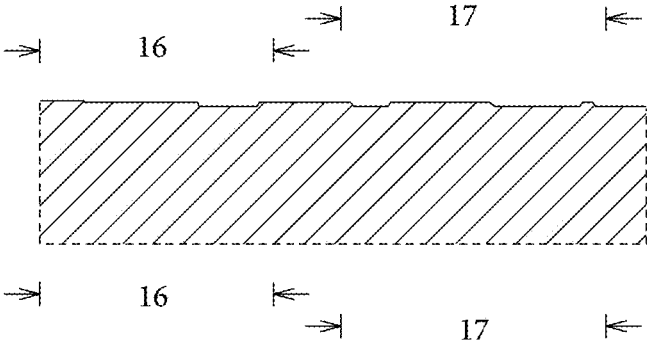

FIG. 13

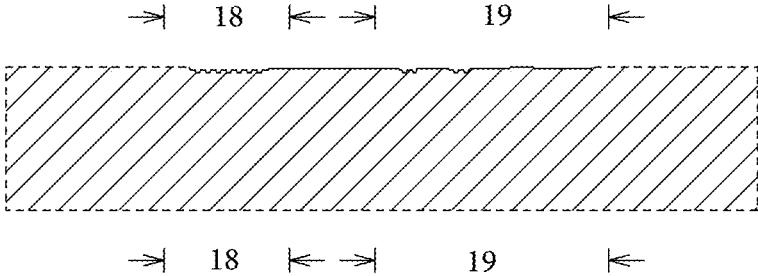

FIG. 14

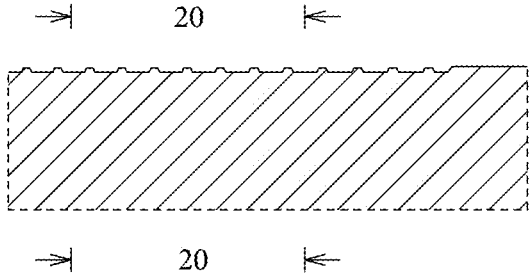

FIG. 15

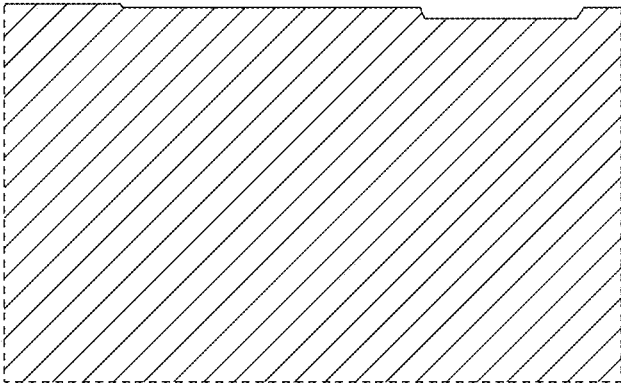

FIG. 16

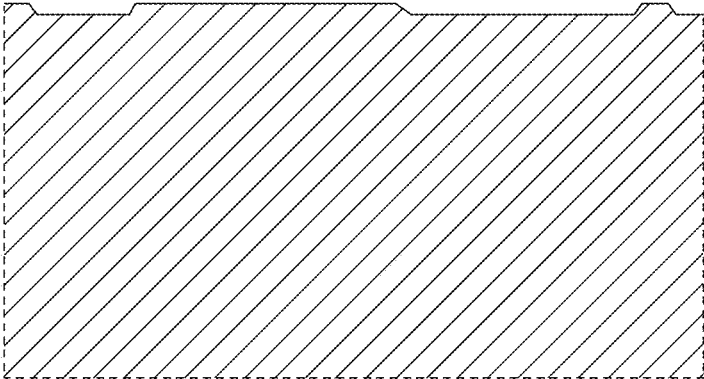

FIG. 17

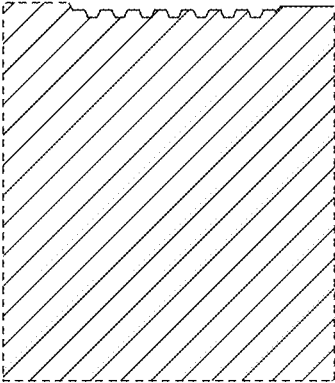

FIG. 18

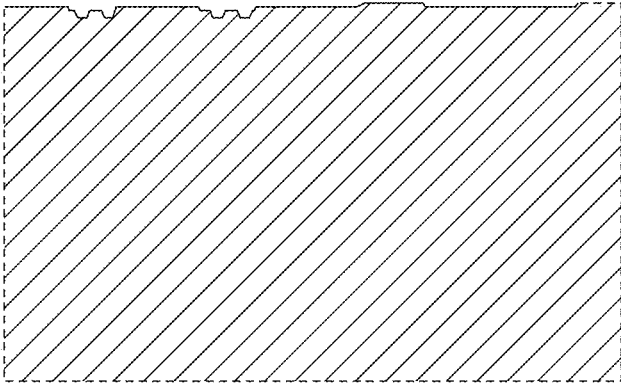

FIG. 19

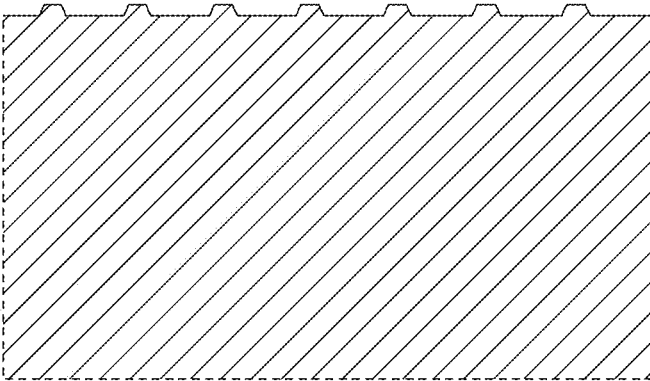

FIG. 20

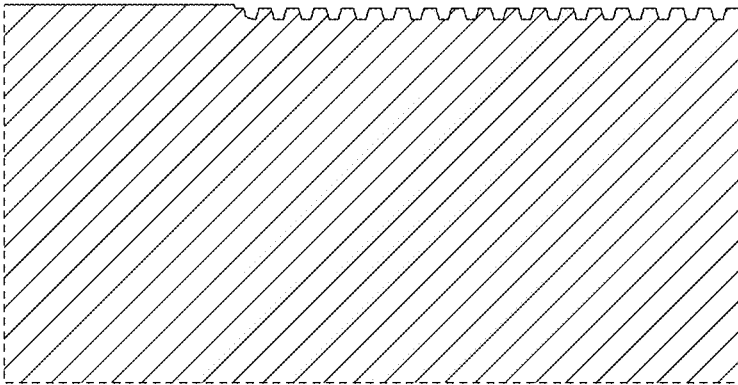

FIG. 21

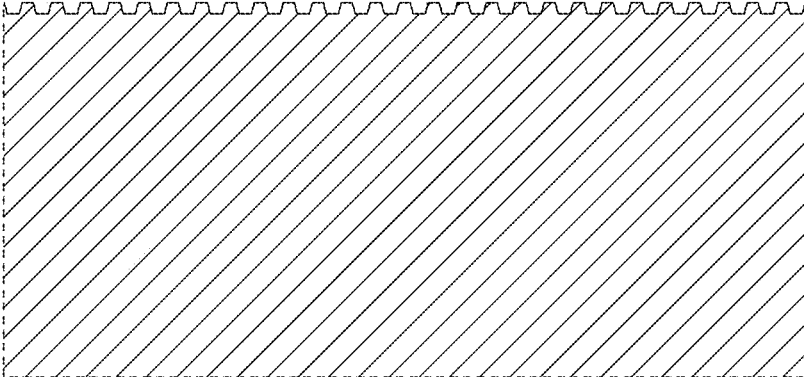

FIG. 22