



US 20110124992A1

(19) **United States**

(12) **Patent Application Publication**  
**Brauker et al.**

(10) **Pub. No.: US 2011/0124992 A1**

(43) **Pub. Date: May 26, 2011**

(54) **OPTIMIZED SENSOR GEOMETRY FOR AN IMPLANTABLE GLUCOSE SENSOR**

(60) Provisional application No. 60/460,825, filed on Apr. 4, 2003.

(75) Inventors: **James H. Brauker**, Addison, MI (US); **Victoria Carr-Brendel**, San Diego, CA (US); **Paul V. Neale**, San Diego, CA (US); **Laura A. Martinson**, La Mesa, CA (US); **Mark A. Tapsak**, Orangeville, PA (US)

**Publication Classification**

(51) **Int. Cl.**  
*A61B 5/1473* (2006.01)  
(52) **U.S. Cl.** ..... **600/345**

(57) **ABSTRACT**

An implantable sensor for use in measuring a concentration of an analyte such as glucose in a bodily fluid, including a body with a sensing region adapted for transport of analytes between the sensor and the bodily fluid, wherein the sensing region is located on a curved portion of the body such that when a foreign body capsule forms around the sensor, a contractile force is exerted by the foreign body capsule toward the sensing region. The body is partially or entirely curved, partially or entirely covered with an anchoring material for supporting tissue ingrowth, and designed for subcutaneous tissue implantation. The geometric design, including curvature, shape, and other factors minimize chronic inflammatory response at the sensing region and contribute to improved performance of the sensor in vivo.

(73) Assignee: **DexCom, Inc.**, San Diego, CA (US)

(21) Appl. No.: **13/015,950**

(22) Filed: **Jan. 28, 2011**

**Related U.S. Application Data**

(60) Continuation of application No. 11/415,631, filed on May 2, 2006, now Pat. No. 7,881,763, which is a division of application No. 10/646,333, filed on Aug. 22, 2003, now Pat. No. 7,134,999.

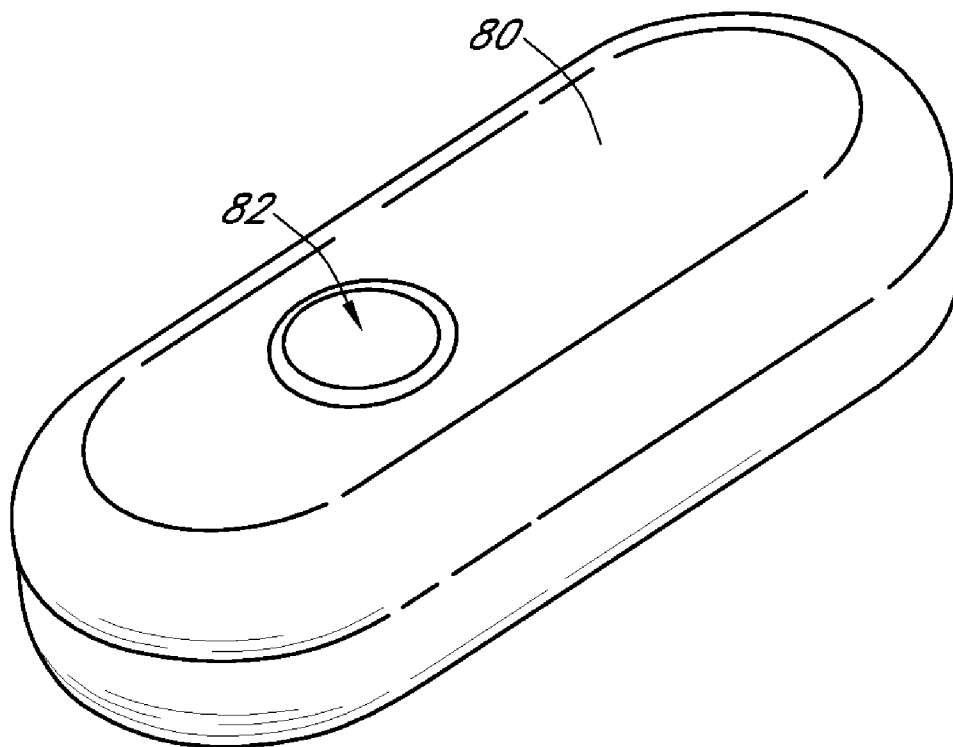

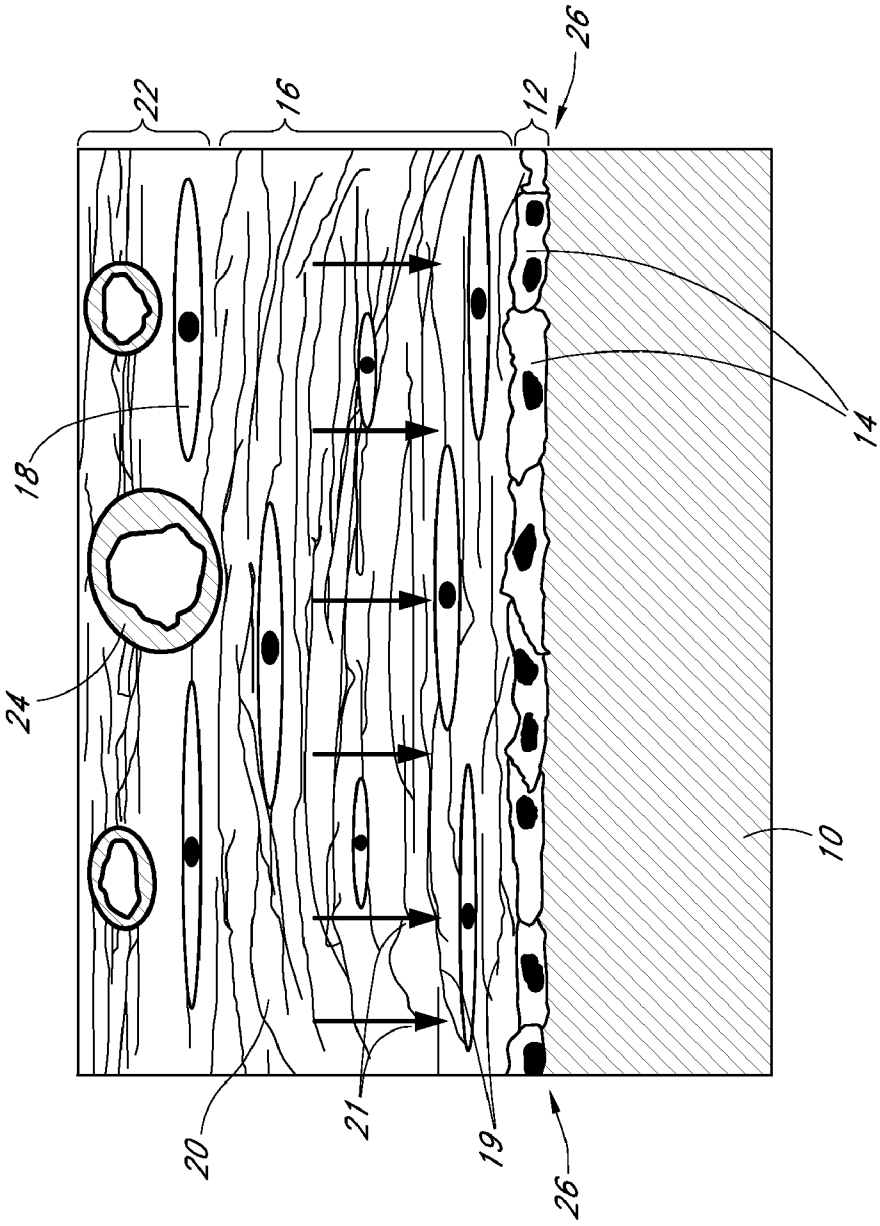

FIG. 1  
(PRIOR ART)

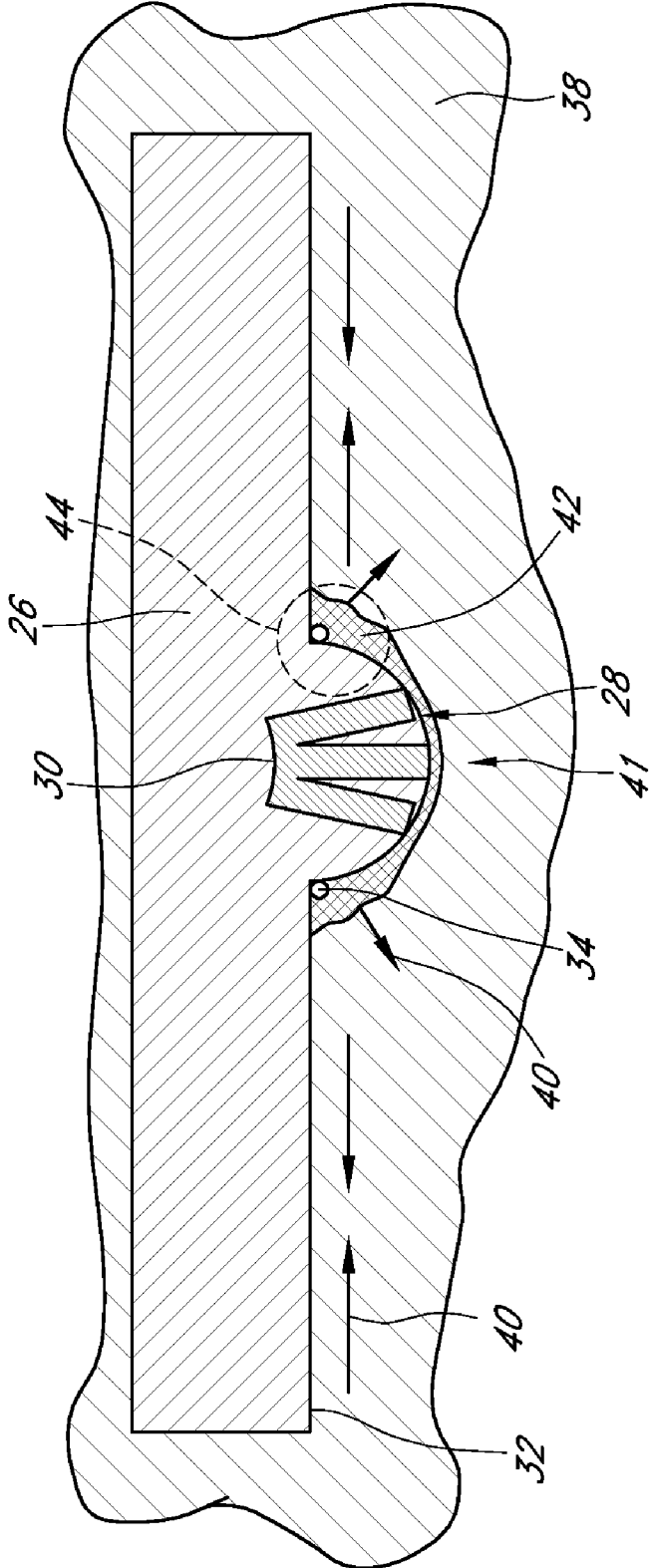

FIG. 2A  
(PRIOR ART)

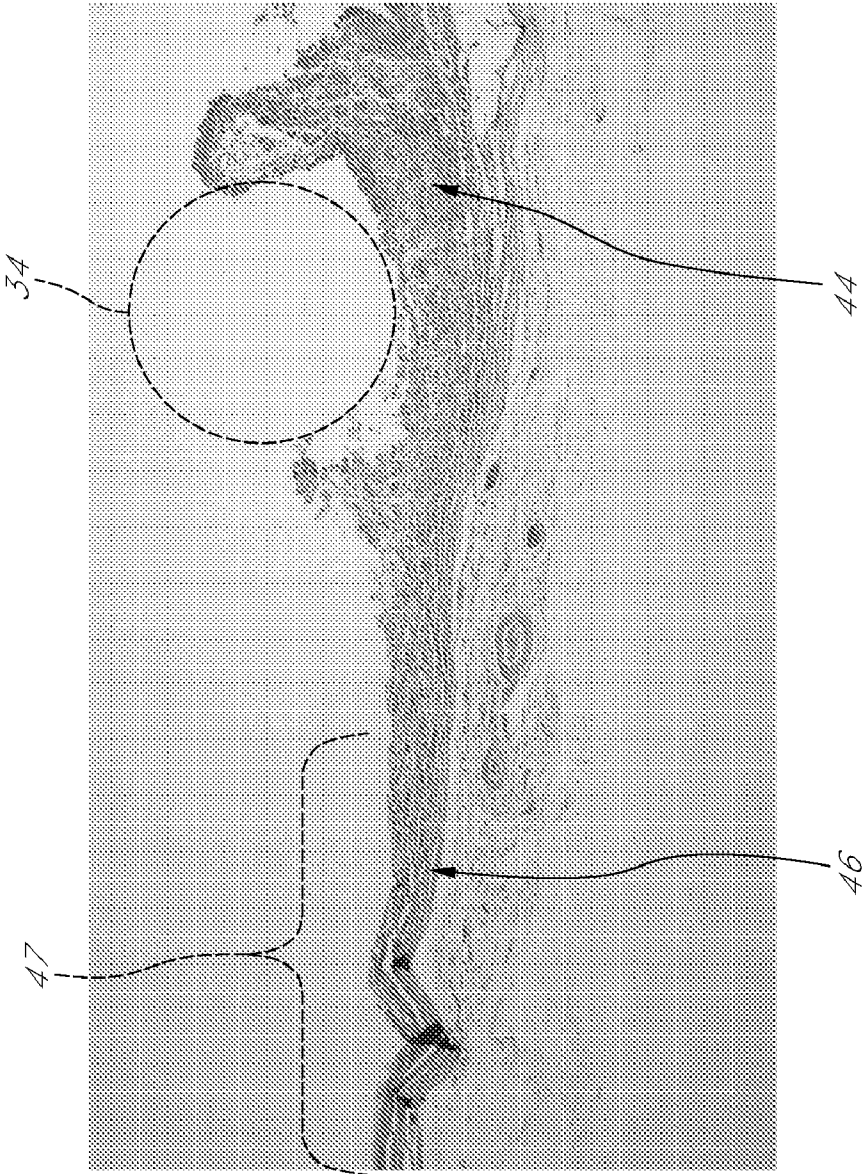
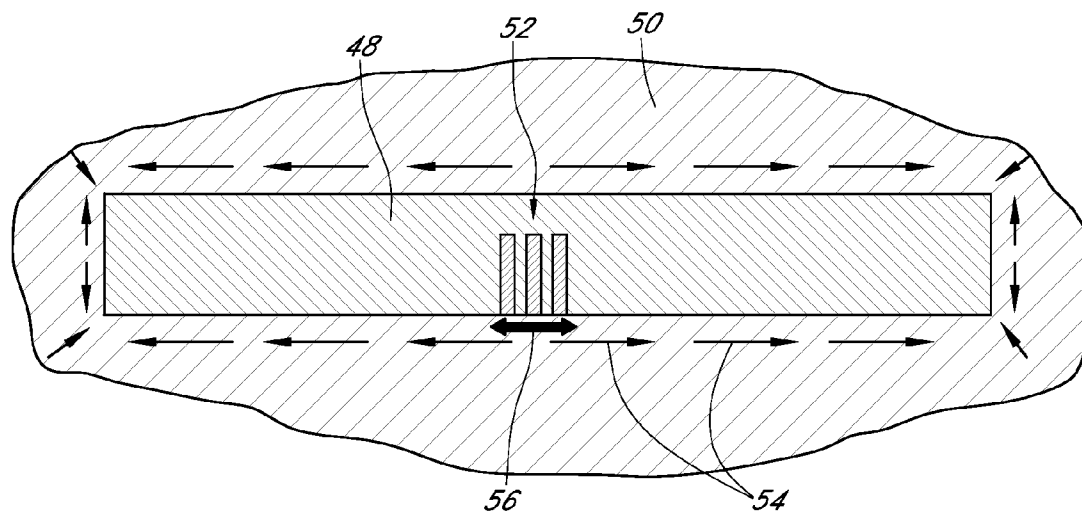
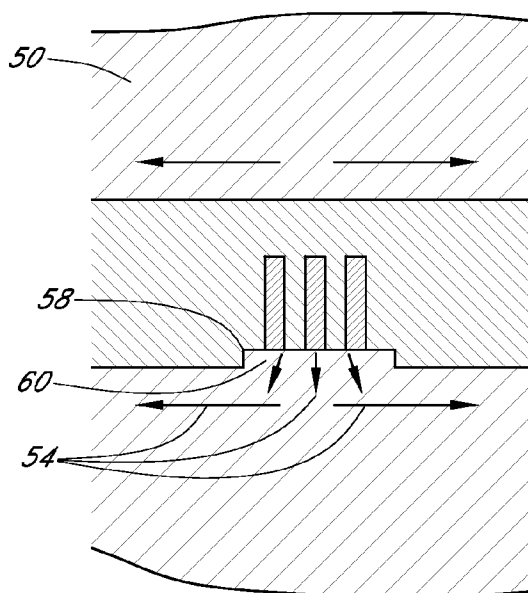

FIG. 2B  
(PRIOR ART)



**FIG. 3A**  
(PRIOR ART)



**FIG. 3B**  
(PRIOR ART)

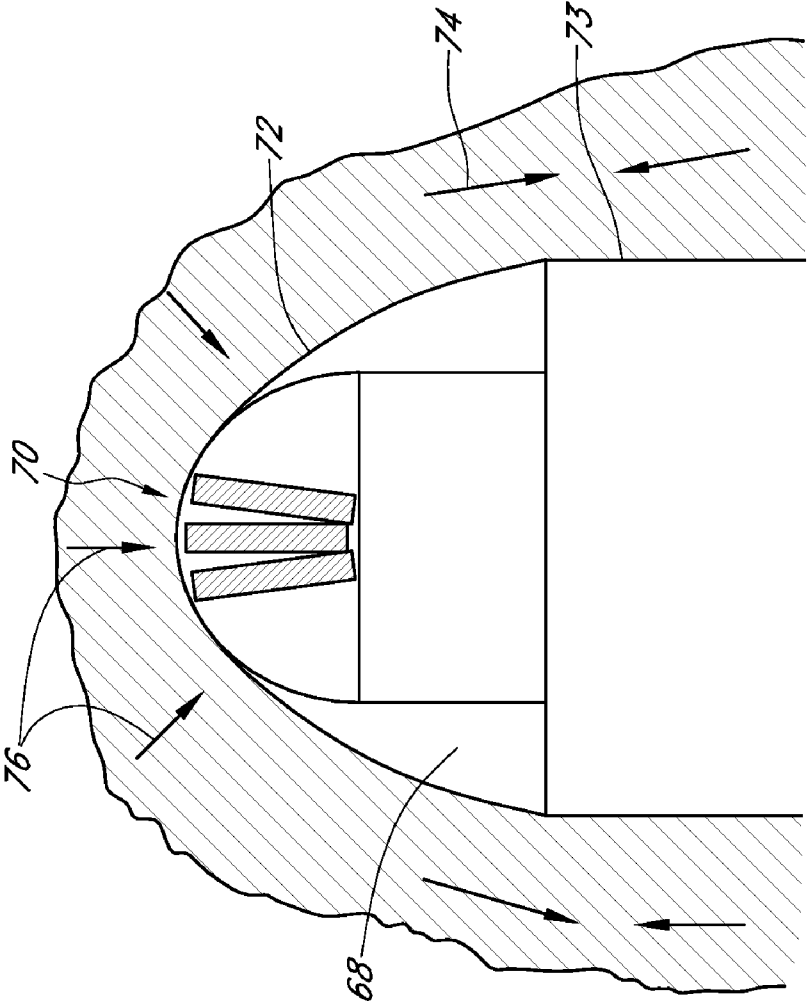

FIG. 4

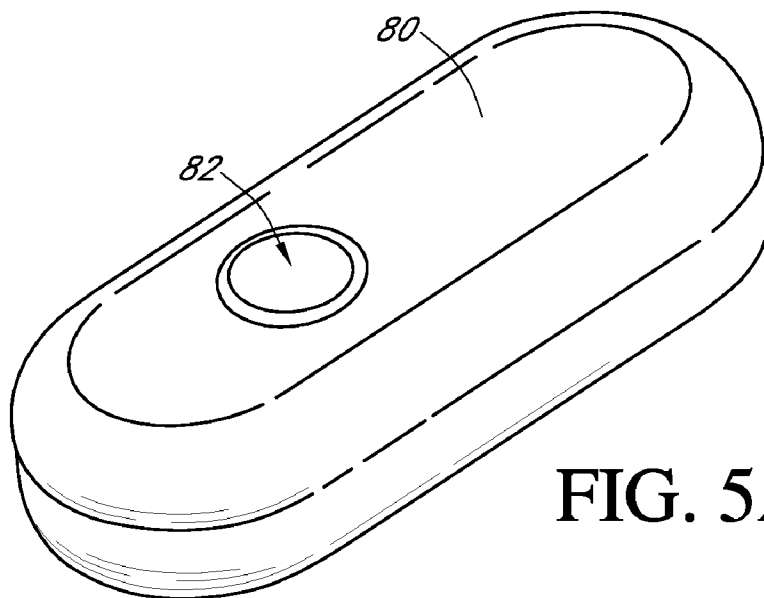

FIG. 5A

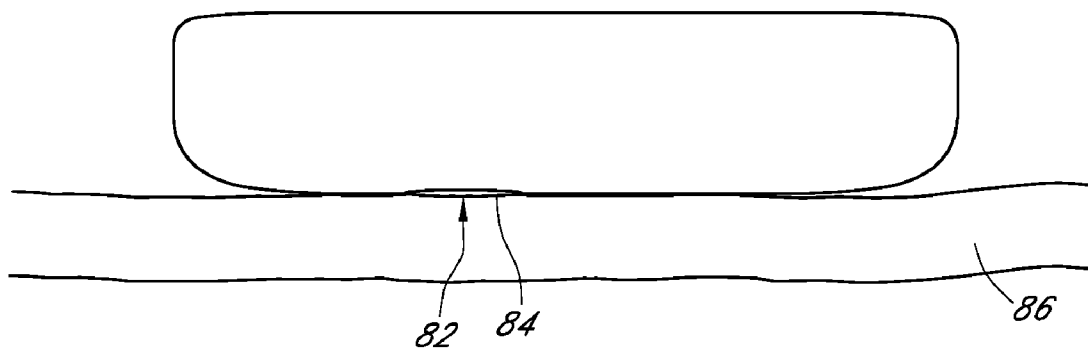

FIG. 5B

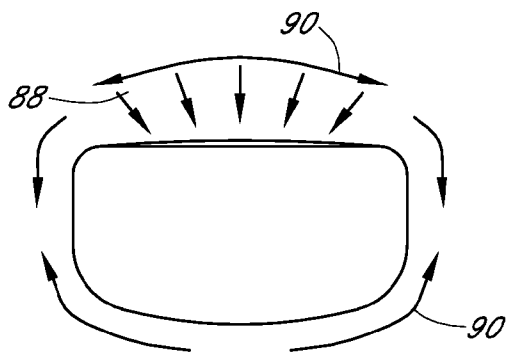

FIG. 5C

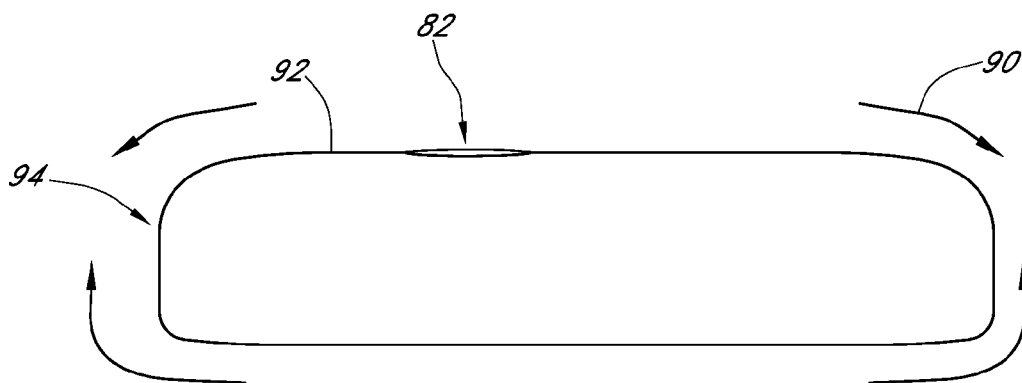

FIG. 5D



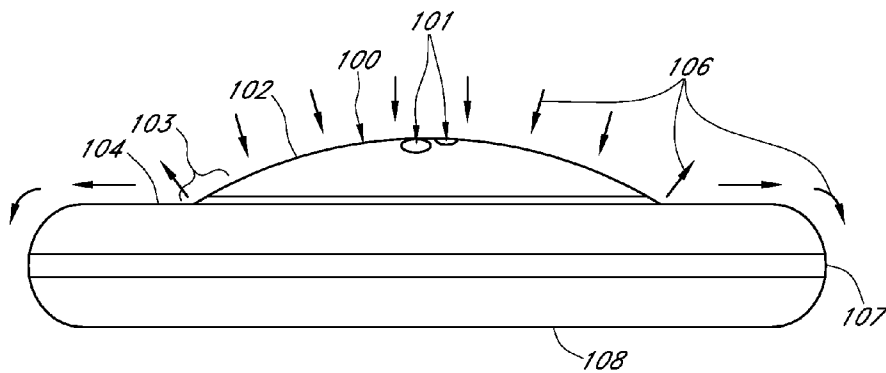

FIG. 6

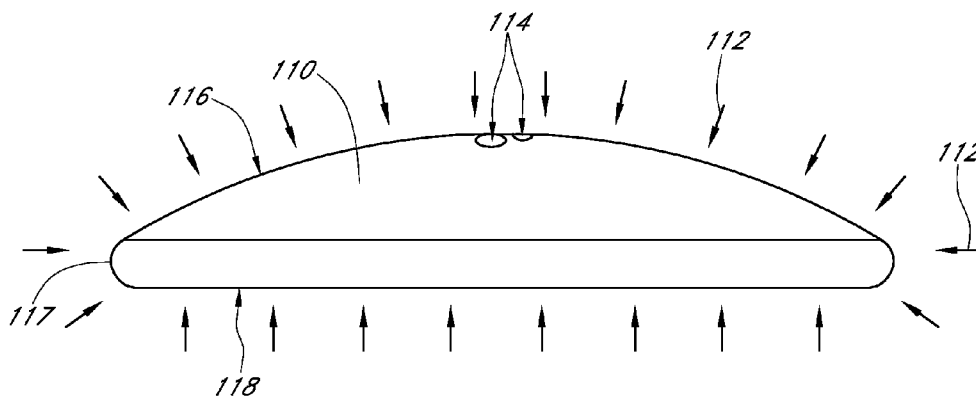

FIG. 7

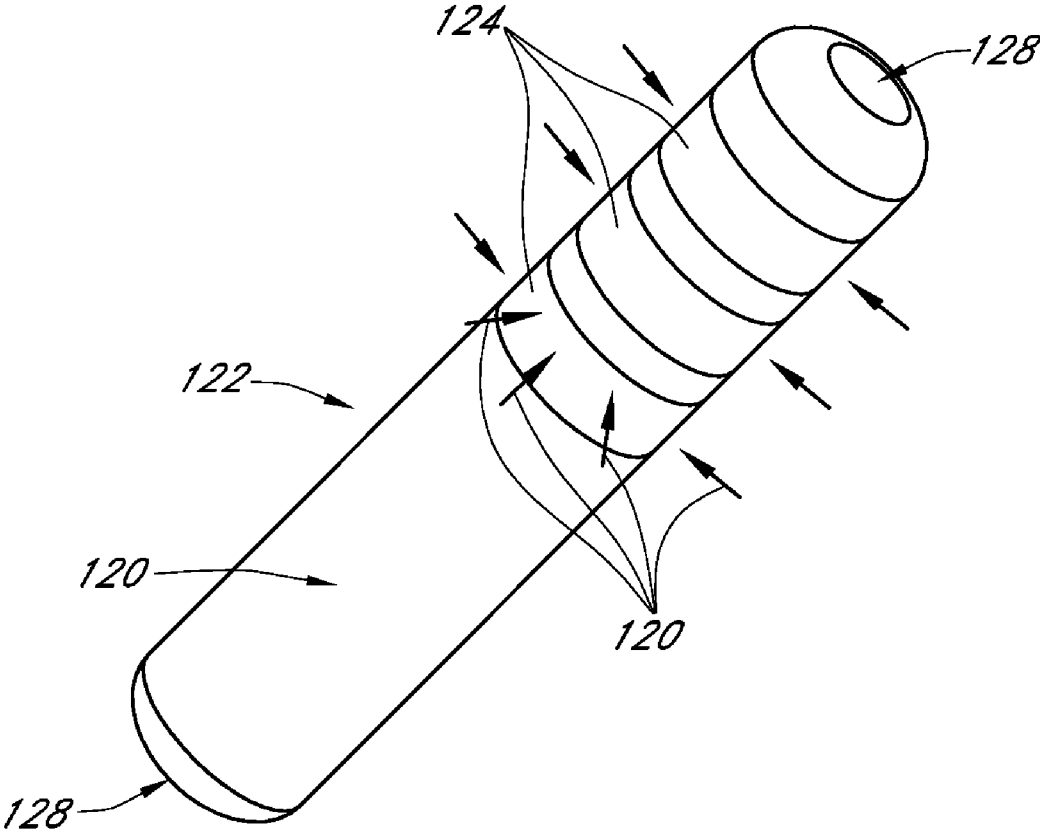

FIG. 8

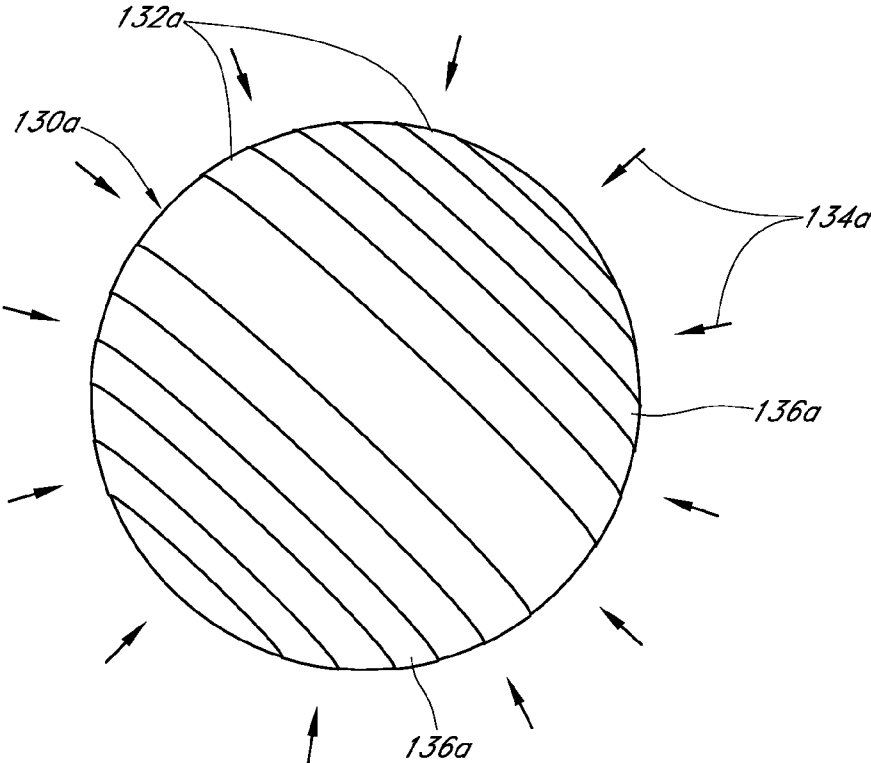

FIG. 9A

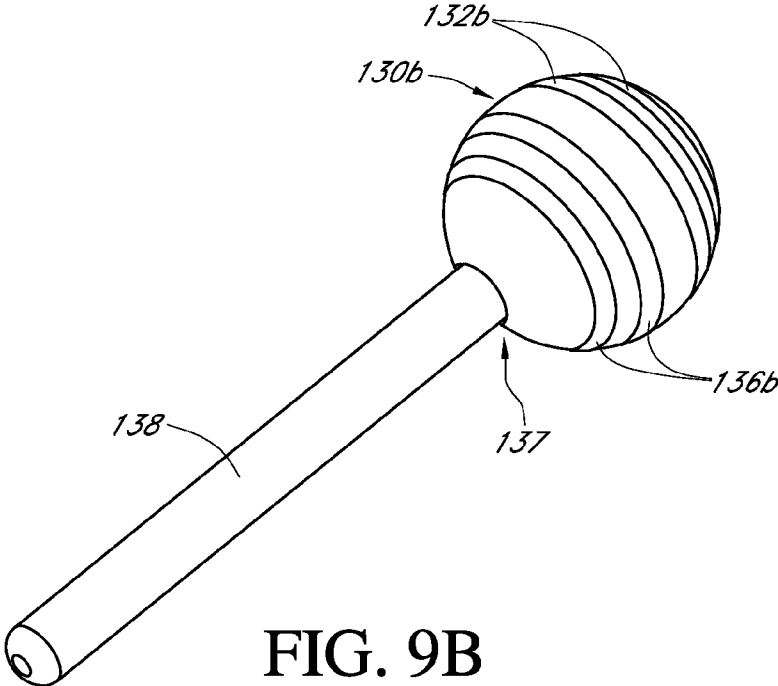

FIG. 9B

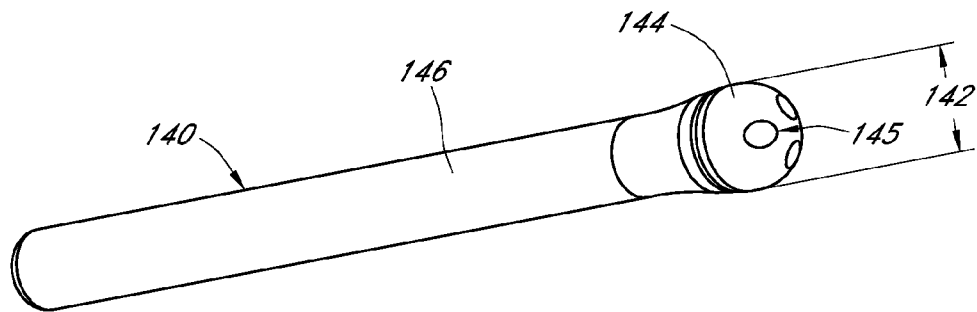

FIG. 10A

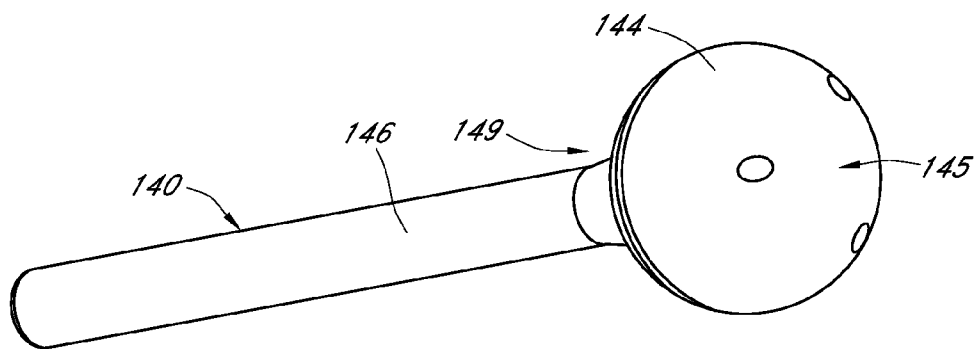

FIG. 10B

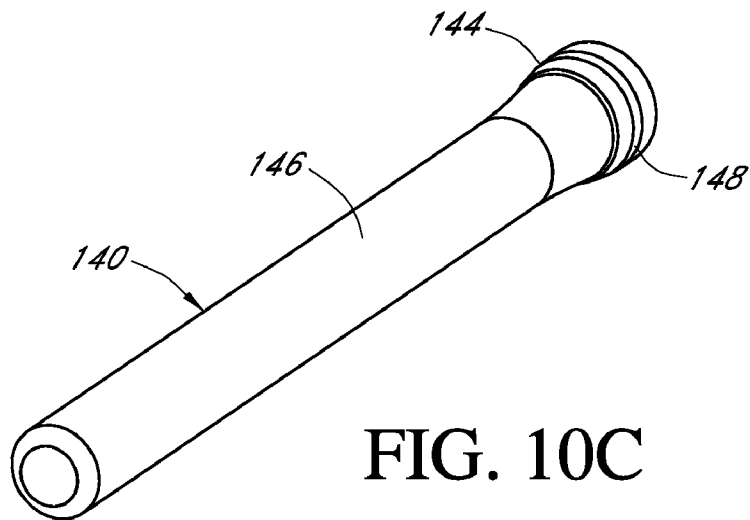

FIG. 10C

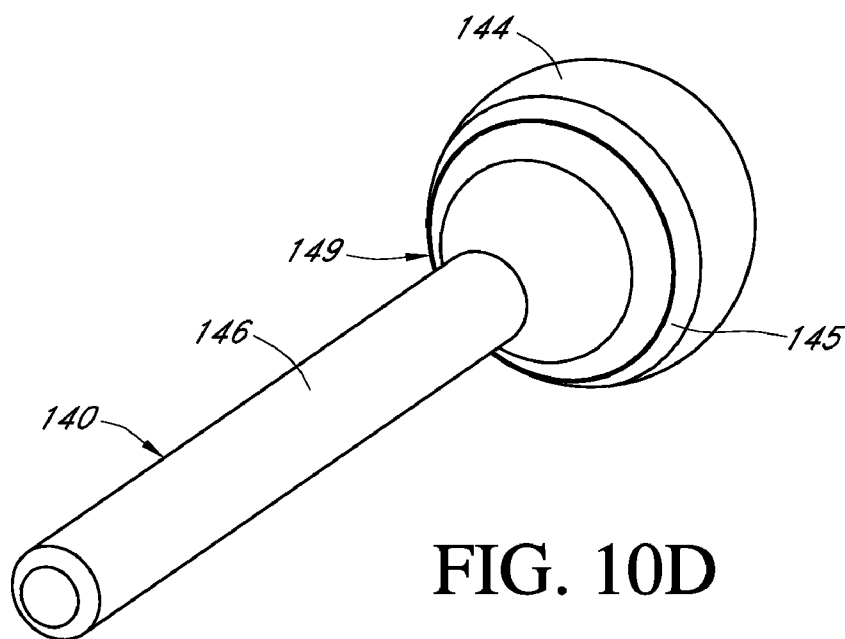

FIG. 10D

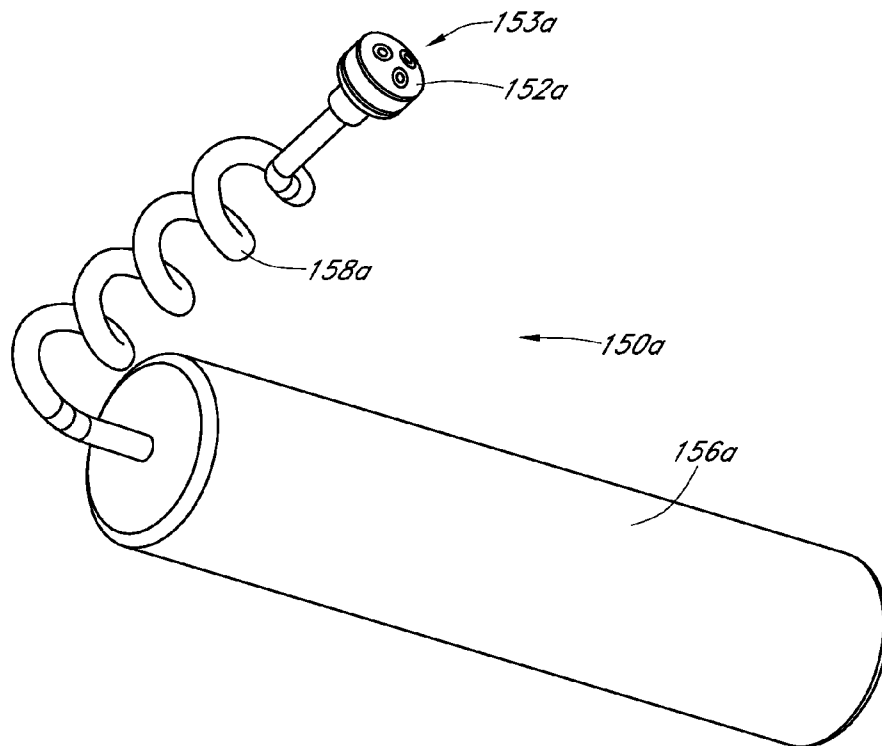

FIG. 11A

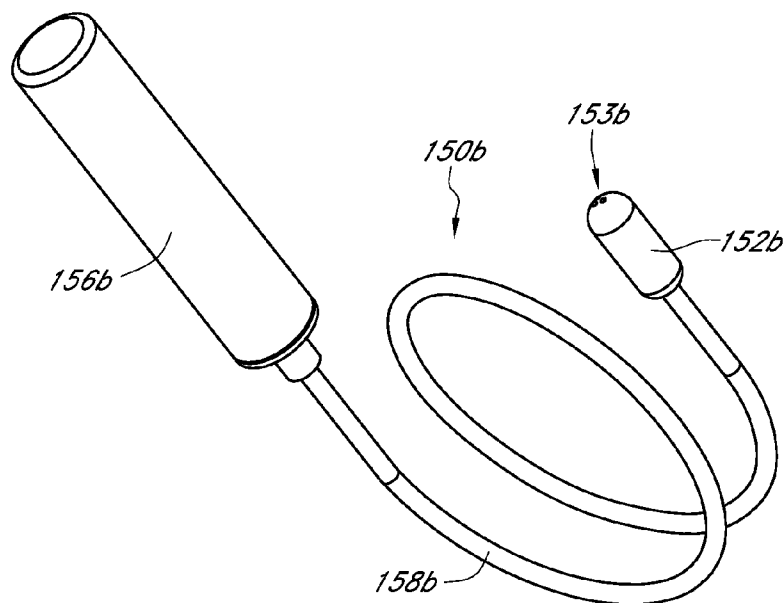

FIG. 11B

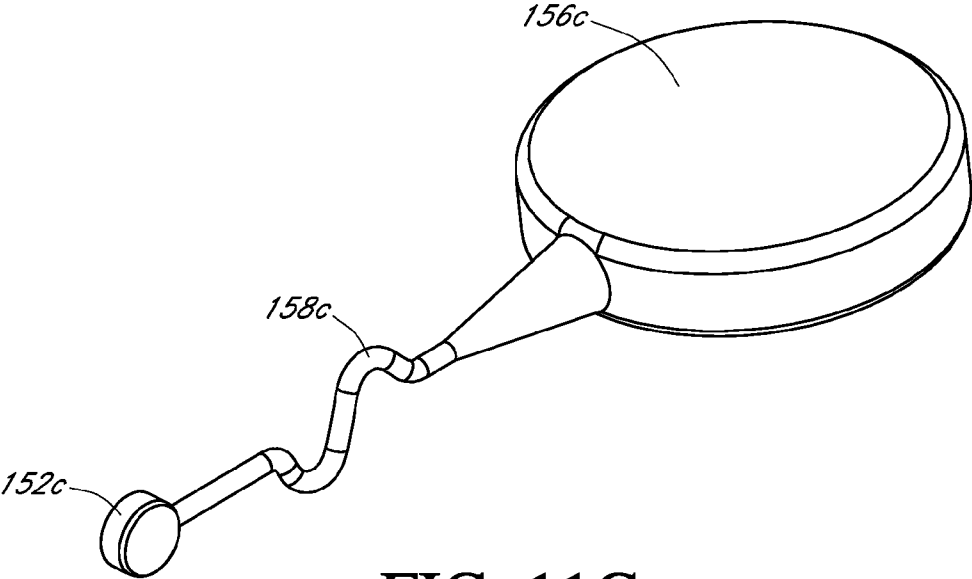

FIG. 11C

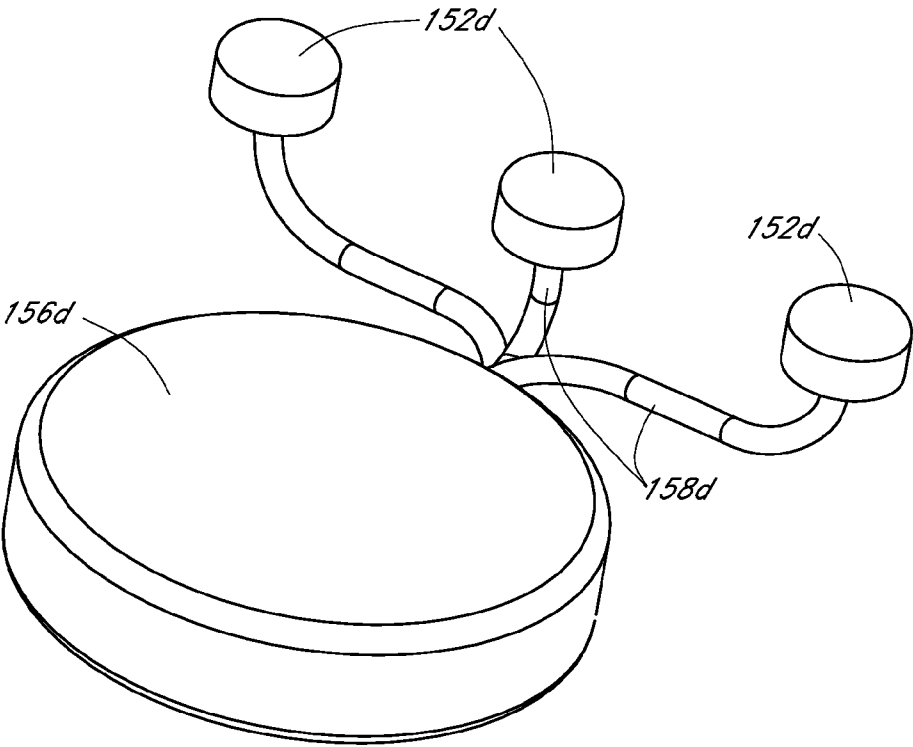

FIG. 11D

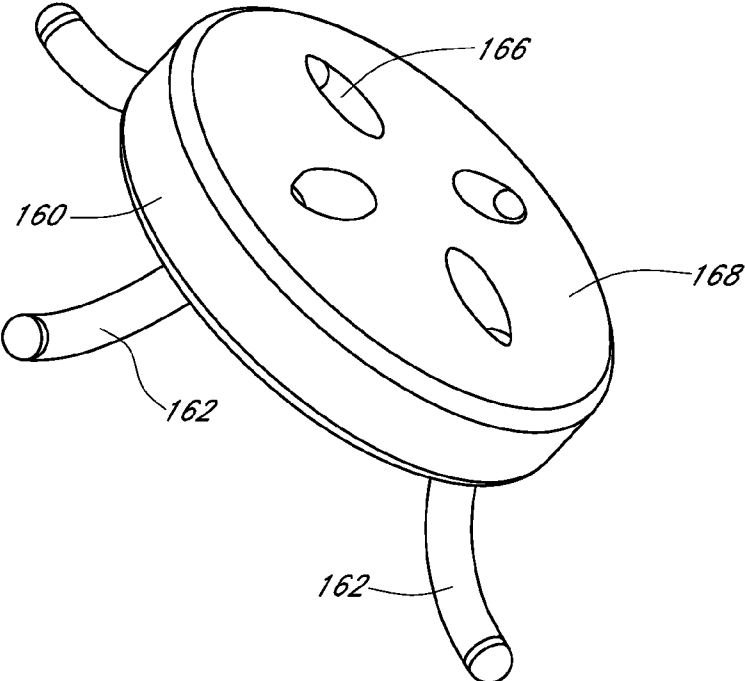

FIG. 12A

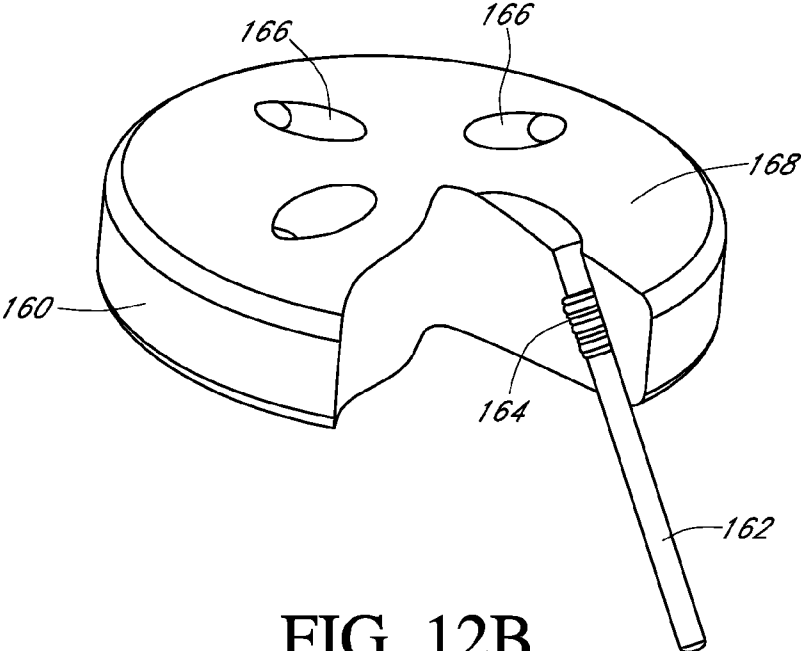

FIG. 12B



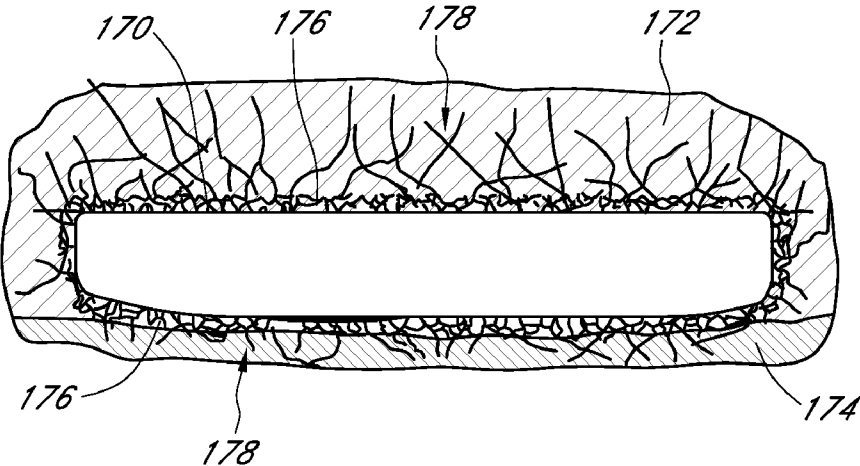

FIG. 13A

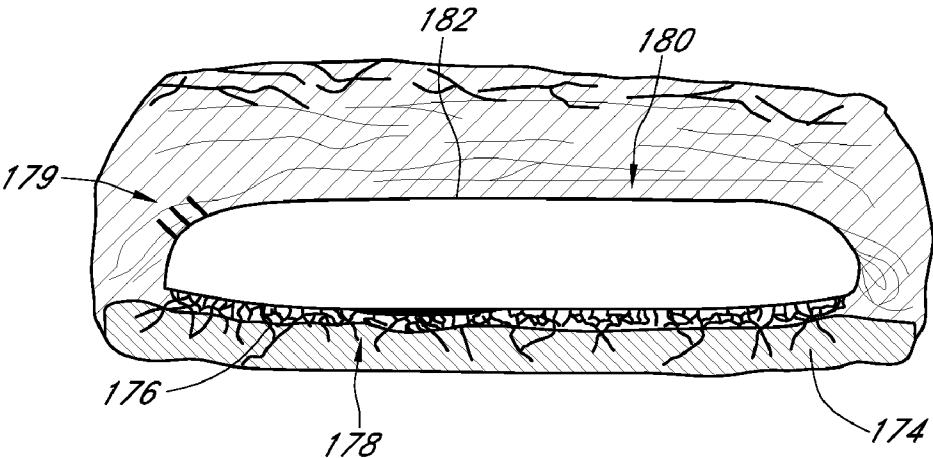

FIG. 13B

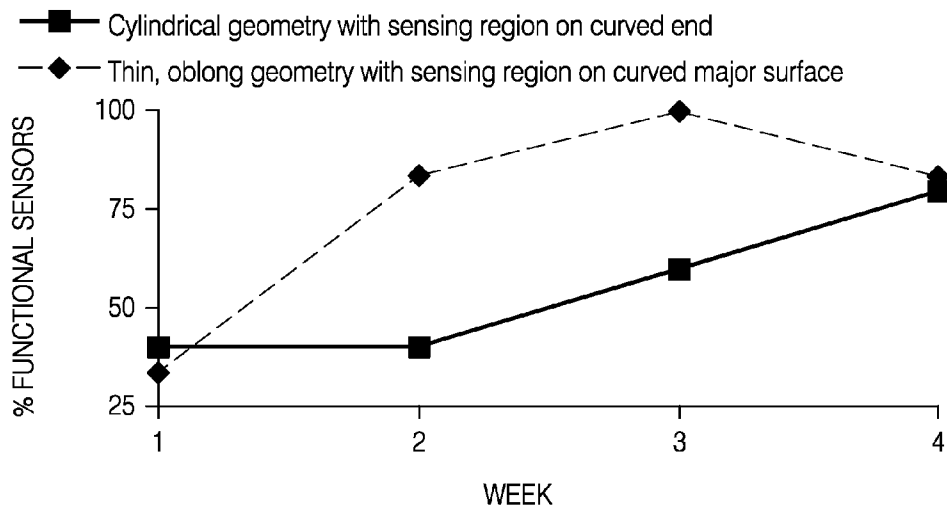

FIG. 14A

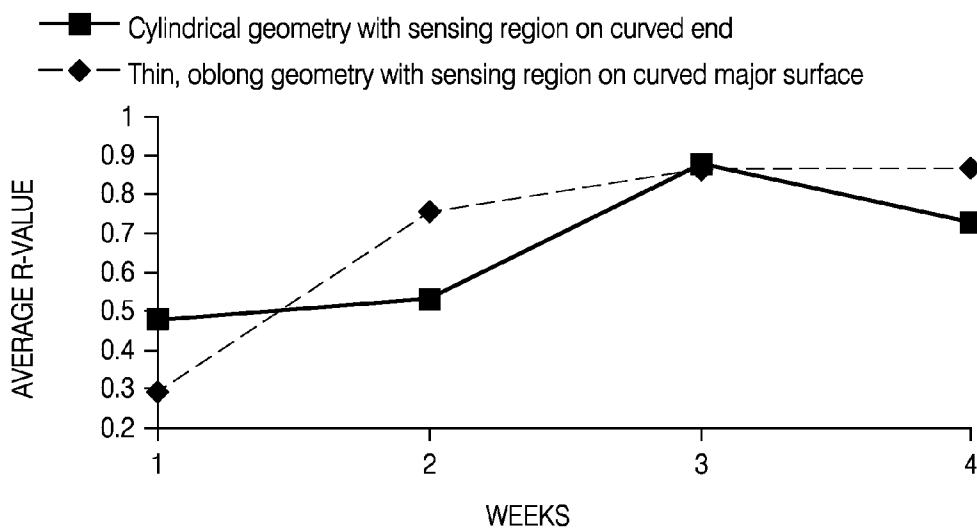

FIG. 14B

**OPTIMIZED SENSOR GEOMETRY FOR AN IMPLANTABLE GLUCOSE SENSOR**

[0001] This application is a continuation of U.S. application Ser. No. 11/415,631 filed May 2, 2006, now U.S. Pat. No. 7,881,763, which is a division of U.S. application Ser. No. 10/646,333 filed Aug. 22, 2003, now U.S. Pat. No. 7,134,999, which claims the benefit of priority under 35 U.S.C. §119(e) to U.S. Provisional Application No. 60/460,825, filed Apr. 4, 2003, the contents of each of which are hereby incorporated by reference in their entirety and are hereby made a part of this specification.

**FIELD OF THE INVENTION**

[0002] The present invention relates generally to implantable sensors that measure the concentration of an analyte in a biological fluid. The sensor geometry optimizes the healing at the sensor-tissue interface and is less amenable to accidental movement due to shear and rotational forces than other sensor configurations.

**BACKGROUND OF THE INVENTION**

[0003] Implantable analyte sensors that are placed in the subcutaneous tissue or other soft tissue sites must develop and sustain a stable biointerface that allows the continuous and timely transport of analytes across the interface between the tissue and the device. For example, in the case of a glucose sensor, glucose must be able to freely diffuse from surrounding blood vessels to a membrane of the sensor. Glucose sensors may be implanted in the subcutaneous tissue or other soft tissue. Such devices include glucose oxidase based amperometric sensors that sense glucose for weeks, months or longer after implantation.

[0004] While the utility of such devices for glucose sensing has been demonstrated, the consistency of function for such devices is not optimal. For a particular device, the sensor may, for example: 1) fail to function (namely, fail to track glucose effectively) in a stable manner during the first few weeks after implantation; 2) not work at all during the first few weeks, but subsequently begin to function in a stable manner; 3) function well during the first few weeks, lose function, then regain effectiveness or never recover function; or 4) work immediately, and continue to function with high accuracy throughout the course of a several month study.

[0005] Glucose sensors with improved acceptance within the host tissue and decreased variability of response are required for reliable functionality in vivo. Accordingly, the present invention discloses systems and methods for providing this improved functionality and consistency of analyte sensor in a host.

**SUMMARY OF THE INVENTION**

[0006] A sensor, especially a sensor suitable for implantation into soft tissue that provides accurate analyte measurements while offering consistency of function is highly desirable.

[0007] Accordingly, in a first embodiment an implantable sensor is provided for use in measuring a concentration of an analyte in a bodily fluid, the sensor including a body including a sensing region adapted for transport of analytes between the sensor and the bodily fluid, wherein the sensing region is located on a curved portion of the body such that when a

foreign body capsule forms around the sensor, a contractile force is exerted by the foreign body capsule toward the sensing region.

[0008] In an aspect of the first embodiment, the sensor is a subcutaneous sensor.

[0009] In an aspect of the first embodiment, the sensor is an intramuscular sensor.

[0010] In an aspect of the first embodiment, the sensor is an intraperitoneal sensor.

[0011] In an aspect of the first embodiment, the sensor is an intrafascial sensor.

[0012] In an aspect of the first embodiment, the sensor is suitable for implantation in an axillary region.

[0013] In an aspect of the first embodiment, the sensor is suitable for implantation in a soft tissue of a body.

[0014] In an aspect of the first embodiment, the sensor is suitable for implantation at the interface between two tissue types.

[0015] In an aspect of the first embodiment, the sensor includes a plurality of sensor regions.

[0016] In an aspect of the first embodiment, the plurality of sensor regions are located on curved portions of the body.

[0017] In an aspect of the first embodiment, the body includes a first major surface and a second major surface, and wherein the sensing region is located on the first surface, and wherein the second surface is flat.

[0018] In an aspect of the first embodiment, the body includes a first major surface and a second major surface, and wherein the sensing region is located on the first major surface, and wherein the second major surface includes a curvature.

[0019] In an aspect of the first embodiment, the body includes a first major surface and a second major surface, and wherein the sensor region is situated at a position on the first major surface offset from a center point of the first major surface.

[0020] In an aspect of the first embodiment, the body includes a first major surface and a second major surface, and wherein the sensor region is situated on the first major surface approximately at a center point of the first major surface.

[0021] In an aspect of the first embodiment, the body includes a first surface and a second surface, and wherein the sensor region is situated approximately at an apex of the first surface.

[0022] In an aspect of the first embodiment, the body includes a first surface and a second surface, and wherein the first surface, when viewed from a direction perpendicular to a center of the first surface, has a substantially rectangular profile.

[0023] In an aspect of the first embodiment, the body includes a first surface and a second surface, and wherein the first surface, when viewed from a direction perpendicular to a center of the first surface, has a substantially rectangular profile with rounded corners.

[0024] In an aspect of the first embodiment, the body includes a first surface and a second surface, and wherein the first surface, when viewed from a direction perpendicular to a center of the first surface, has a substantially oval profile.

[0025] In an aspect of the first embodiment, the body includes a first surface and a second surface, and wherein the first surface, when viewed from a direction perpendicular to a center of the first surface, has a substantially circular profile.

- [0026] In an aspect of the first embodiment, the body is substantially cuboidal defined by six faces, eight vertices, and twelve edges, wherein at least one of the faces includes the sensing region.
- [0027] In an aspect of the first embodiment, at least two of the faces are substantially curved.
- [0028] In an aspect of the first embodiment, at least four of the faces are substantially curved.
- [0029] In an aspect of the first embodiment, all six of the faces are substantially curved.
- [0030] In an aspect of the first embodiment, the edges are substantially rounded.
- [0031] In an aspect of the first embodiment, the vertices are substantially rounded.
- [0032] In an aspect of the first embodiment, the entire body is curved.
- [0033] In an aspect of the first embodiment, the body is substantially cylindrical defined by a curved lateral surface and two ends, and wherein the sensor region is located on the lateral surface.
- [0034] In an aspect of the first embodiment, the body is substantially cylindrical defined by a curved lateral surface and two ends, and wherein at least one of the ends includes the substantially curved portion on which the sensor region is located.
- [0035] In an aspect of the first embodiment, the body is substantially spherical.
- [0036] In an aspect of the first embodiment, the body is substantially ellipsoidal.
- [0037] In an aspect of the first embodiment, the body includes a first surface on which the sensing region is located and a second surface, and wherein the first surface includes anchoring material thereon for supporting tissue ingrowth.
- [0038] In an aspect of the first embodiment, the second surface is located opposite the first surface, and wherein the second surface includes anchoring material thereon for supporting tissue ingrowth.
- [0039] In an aspect of the first embodiment, the second surface is located opposite the first surface, and wherein the second surface is substantially smooth and includes a bio-compatible material that is non-adhesive to tissues.
- [0040] In an aspect of the first embodiment, the second surface is curved.
- [0041] In an aspect of the first embodiment, a mechanical anchoring mechanism is formed on the body.
- [0042] In an aspect of the first embodiment, the curved portion includes a plurality of radii of curvature.
- [0043] In an aspect of the first embodiment, the curved portion includes a radius of curvature between about 0.5 mm and about 10 cm.
- [0044] In an aspect of the first embodiment, the curved portion includes a radius of curvature between about 1 cm and about 5 cm.
- [0045] In an aspect of the first embodiment, the curved portion includes a radius of curvature between about 2 cm and about 3 cm.
- [0046] In an aspect of the first embodiment, the curved portion includes a radius of curvature between about 2.5 cm and about 2.8 cm.
- [0047] In an aspect of the first embodiment, the sensor includes a major surface and wherein the curved portion is located on at least a portion of the major surface.
- [0048] In an aspect of the first embodiment, the body further includes a flat portion adjacent the curved portion.
- [0049] In an aspect of the first embodiment, an interface between the flat portion and the curved portion includes a gradual transition.
- [0050] In an aspect of the first embodiment, the body includes a first major surface on which the sensing region is located and a second major surface, and wherein the first and second major surfaces together account for at least about 40% of the surface area of the device.
- [0051] In an aspect of the first embodiment, the first and second major surfaces together account for at least about 50% of the surface area of the device.
- [0052] In an aspect of the first embodiment, the body includes a first major surface on which the sensing region is located and a second major surface, wherein the first major surface has edges between which a width of the first major surface can be measured, and wherein the sensing region is spaced away from the edges by a distance that is at least about 10% of the width of the first major surface.
- [0053] In an aspect of the first embodiment, the sensing region is spaced away from the edges by a distance that is at least about 15% of the width of the first major surface.
- [0054] In an aspect of the first embodiment, the sensing region is spaced away from the edges by a distance that is at least about 20% of the width of the first major surface.
- [0055] In an aspect of the first embodiment, the sensing region is spaced away from the edges by a distance that is at least about 25% of the width of the first major surface.
- [0056] In an aspect of the first embodiment, the sensing region is spaced away from the edges by a distance that is at least about 30% of the width of the first major surface.
- [0057] In an aspect of the first embodiment, the spacing of the sensing region from the edges is true for at least two width measurements, which measurements are taken generally transverse to each other.
- [0058] In an aspect of the first embodiment, the body includes a first major surface on which the sensing region is located and a second major surface, wherein the first major surface is at least slightly convex.
- [0059] In an aspect of the first embodiment, a reference plane may be defined that touches the first major surface at a point spaced in from edges of the first major surface, and is generally parallel to the first major surface, and is spaced away from opposite edges of the first major surface due to convexity of the first major surface, and wherein a location of an edge is the point at which a congruent line or a normal line is angled 45 degrees with respect to the reference plane.
- [0060] In an aspect of the first embodiment, the reference plane is spaced from the edges a distance that is at least about 3% from the edges, and not more than 50% of the width.
- [0061] In an aspect of the first embodiment, the reference plane is spaced from the edges a distance that is at least about 3% from the edges, and not more than 25% of the width.
- [0062] In an aspect of the first embodiment, the reference plane is spaced from the edges a distance that is at least about 3% from the edges, and not more than 15% of the width.
- [0063] In an aspect of the first embodiment, the body includes a first major surface on which the sensing region is located, and wherein edges of the first major surface are rounded and transition smoothly away from the first major surface.
- [0064] In an aspect of the first embodiment, the body defines a surface area, and wherein between 10% and 100% of the surface area is convexly curved.

[0065] In an aspect of the first embodiment, the body defines a surface area, and wherein a substantial portion of the surface area is convexly curved.

[0066] In an aspect of the first embodiment, the body defines a surface area, and where at least about 90% of the surface area is convexly curved.

[0067] In an aspect of the first embodiment, the body includes plastic.

[0068] In an aspect of the first embodiment, the plastic is selected from the group consisting of thermoplastic and thermoset.

[0069] In an aspect of the first embodiment, the thermoset is epoxy.

[0070] In an aspect of the first embodiment, the thermoset is silicone.

[0071] In an aspect of the first embodiment, the thermoset is polyurethane.

[0072] In an aspect of the first embodiment, the plastic is selected from the group consisting of metal, ceramic, and glass.

[0073] In an aspect of the first embodiment, a porous bio-interface material that covers at least a portion of the sensing region.

[0074] In an aspect of the first embodiment, the biointerface material includes interconnected cavities dimensioned and arranged to create contractile forces that counteract with the generally uniform downward fibrous tissue contracture caused by the foreign body capsule in vivo and thereby interfere with formation of occlusive cells.

[0075] In an aspect of the first embodiment, the sensor is a glucose sensor.

[0076] In a second embodiment, an implantable sensor is provided for use in measuring a concentration of an analyte in a bodily fluid, the sensor including: a body including a sensing region on a major surface of the body, wherein the major surface includes a continuous curvature substantially across the entire surface such that when a foreign body capsule forms around the sensor, a contractile force is exerted by the foreign body capsule toward the sensing region.

[0077] In a third embodiment, a wholly implantable sensor is provided to measure a concentration of an analyte in a bodily fluid, including: a wholly implantable body including a sensing region adapted for transport of analytes between the sensor and the bodily fluid, wherein the sensing region is located on a curved portion of a first surface of the body and wherein the first surface includes anchoring material thereon for supporting tissue ingrowth.

[0078] In a fourth embodiment, an implantable sensor is provided to measure a concentration of an analyte in a bodily fluid, including: a body having a first major surface and, opposite thereto, a second major surface, wherein the first major surface is generally planar, slightly convex, and has rounded edges, with a sensor region located on the first major surface that is spaced away from the rounded edges, wherein the first major surface is sufficiently convex that when a foreign body capsule forms around the sensor, contractile forces are exerted thereby generally uniformly towards the sensing region.

[0079] In a fifth embodiment, an implantable sensor is provided for use in measuring a concentration of an analyte in a bodily fluid, the sensor including: a body, the body including a sensing region adapted for transport of analytes between the sensor and the bodily fluid, wherein the sensing region is

located on a curved portion of the body, and wherein a thermoset material substantially encapsulates the body outside the sensing region.

[0080] In a sixth embodiment, an implantable sensor for use in measuring a concentration of an analyte in a bodily fluid, the sensor including: sensing means for measuring a concentration of analyte in a bodily fluid; and housing means for supporting the sensing means, wherein the sensing means is located on a curved portion of housing means such that when a foreign body capsule forms around the housing means, a contractile force is exerted by the foreign body capsule toward the sensing means.

[0081] In a seventh embodiment, an implantable drug delivery device is provided that allows transport of analytes between the device and a bodily fluid, the device including: a body including an analyte transport region adapted for transport of analytes between the device and the bodily fluid, wherein the transport region is located on a curved portion of the body such that when a foreign body capsule forms around the device, a contractile force is exerted by the foreign body capsule toward the analyte transport region.

[0082] In an eighth embodiment, an implantable cell transplantation device is provided that allows transport of analytes between the device and a bodily fluid, the device including: a body including an analyte transport region adapted for transport of analytes between the device and the bodily fluid, wherein the transport region is located on a curved portion of the body such that when a foreign body capsule forms around the device, a contractile force is exerted by the foreign body capsule toward the analyte transport region.

#### BRIEF DESCRIPTION OF THE DRAWINGS

[0083] FIG. 1 is an illustration of classical foreign body response to an object implanted under the skin.

[0084] FIG. 2A is schematic side view of a prior art device that has a sensing region with an abrupt inside turn, causing a sub-optimal foreign body response.

[0085] FIG. 2B is a photomicrograph of the foreign body response to a portion of the device of FIG. 2A, after formation of the foreign body capsule and subsequent explantation, showing thickened immune response adjacent to the abrupt inside turn.

[0086] FIG. 3A is a schematic side view of another prior art device that has flattened surfaces across the entire device, and particularly across the sensing region, causing sub-optimal foreign body capsule healing.

[0087] FIG. 3B is a schematic side view of the sensing region of yet another device that has flattened surfaces across the entire device, and an inset sensing region, which is an example of another device that causes sub-optimal foreign body capsule healing in implantable sensors.

[0088] FIG. 4 is a cross-sectional view of the sensing region of an analyte sensor in one embodiment of the present invention, wherein the sensing region is continuously curved, thereby causing contractile forces from the foreign body capsule to press downwardly on the sensing region.

[0089] FIG. 5A is a perspective view of an analyte sensor in another embodiment, including a thin oblong body, a curved sensing region, and an overall curved surface on which the sensing region is located, thereby causing contractile forces from the foreign body capsule to press downward on the sensor head.

[0090] FIG. 5B is the analyte sensor of FIG. 5A shown implanted with the sensing region adjacent to the fascia underlying the subcutaneous space, and overlaying adjacent muscle.

[0091] FIG. 5C is an end view of the analyte sensor of FIG. 5A showing the contractile forces caused by the foreign body capsule.

[0092] FIG. 5D is a side view of the analyte sensor of FIG. 5A.

[0093] FIG. 6 is a perspective view of sensor geometry in an alternative embodiment wherein the sensor includes a curved sensor region and a flat region, wherein the interface between the flat region and the curved region includes a gradual transition.

[0094] FIG. 7 is a perspective view of sensor geometry in an alternative embodiment wherein the entire sensor body is curved.

[0095] FIG. 8 is a perspective view of sensor geometry in an alternative embodiment including a cylindrical geometry wherein a plurality of sensing regions are located on the curved lateral surface of the sensor body.

[0096] FIG. 9A is a perspective view of sensor geometry in an alternative embodiment including a substantially spherical body wherein a plurality of sensing regions are located about the circumference of the sphere.

[0097] FIG. 9B is a perspective view of a sensor geometry in an alternative embodiment including a substantially spherical body with a rod extending therefrom.

[0098] FIGS. 10A to 10D are perspective views of a sensor that has an expandable sensing body in one embodiment. FIGS. 10A and 10C are views of the sensor with the sensing body in a collapsed state, FIGS. 10B and 10D are views of the sensor with the sensing body in an expanded state.

[0099] FIGS. 11A to 11D are perspective views of sensors wherein one or more sensing bodies are tethered to an electronics body in a variety of alternative embodiments.

[0100] FIGS. 12A to 12B are perspective views of a sensor in an alternative embodiment wherein an electronics body is independent of the sensing bodies in a preassembled state and wherein the sensing bodies are independently inserted (and operatively connected) to the electronics body in a minimally invasive manner.

[0101] FIG. 13A is a side schematic view of an analyte sensor with anchoring material on a first and second major surface of the device, including the surface on which the sensing region is located, wherein the analyte sensor is implanted subcutaneously and is ingrown with fibrous, vascularized tissue.

[0102] FIG. 13B is a side schematic view of an analyte sensor with anchoring material on a first major surface on which the sensing region is located, and wherein a second major surface is substantially smooth.

[0103] FIG. 14A is a graph showing the percentage of functional sensors from a study of two different sensor geometries implanted in a host.

[0104] FIG. 14B is a graph showing the average R-value of sensors from a study of two different sensor geometries implanted in a host.

#### DETAILED DESCRIPTION OF THE PREFERRED EMBODIMENT

[0105] The following description and examples illustrate some exemplary embodiments of the disclosed invention in detail. Those of skill in the art will recognize that there are

numerous variations and modifications of this invention that are encompassed by its scope. Accordingly, the description of a certain exemplary embodiment should not be deemed to limit the scope of the present invention.

#### Definitions

[0106] In order to facilitate an understanding of the disclosed invention, a number of terms are defined below.

[0107] The term “analyte,” as used herein, is a broad term and is used in its ordinary sense, including, without limitation, to refer to a substance or chemical constituent in a biological fluid (for example, blood, interstitial fluid, cerebral spinal fluid, lymph fluid or urine) that can be analyzed. Analytes may include naturally occurring substances, artificial substances, metabolites, and/or reaction products. In some embodiments, the analyte for measurement by the sensor heads, devices, and methods is glucose. However, other analytes are contemplated as well, including but not limited to acarboxyprothrombin; acylcarnitine; adenine phosphoribosyl transferase; adenosine deaminase; albumin; alpha-feto-protein; amino acid profiles (arginine (Krebs cycle), histidine/urocanic acid, homocysteine, phenylalanine/tyrosine, tryptophan); adrenostenedione; antipyrine; arabinitol enantiomers; arginase; benzoylcegonine (cocaine); biotinidase; bioprotein; c-reactive protein; carbon dioxide; carnitine; carnitine; CD4; ceruloplasmin; chenodeoxycholic acid; chloroquine; cholesterol; cholinesterase; conjugated 1-β hydroxy-cholic acid; cortisol; creatine kinase; creatine kinase MM isoenzyme; cyclosporin A; d-penicillamine; de-ethyl-chloroquine; dehydroepiandrosterone sulfate; DNA (acetyl-ator polymorphism, alcohol dehydrogenase, alpha 1-antitrypsin, cystic fibrosis, Duchenne/Becker muscular dystrophy, glucose-6-phosphate dehydrogenase, hemoglobinopathies, A,S,C,E, D-Punjab, beta-thalassemia, hepatitis B virus, HCMV, HIV-1, HTLV-1, Leber hereditary optic neuropathy, MCAD, RNA, PKU, Plasmodium vivax, sexual differentiation, 21-deoxycortisol); desbutylhalofantrine; dihydropteridine reductase; diphtheria/tetanus antitoxin; erythrocyte arginase; erythrocyte protoporphyrin; esterase D; fatty acids/acylglycines; free β-human chorionic gonadotropin; free erythrocyte porphyrin; free thyroxine (FT4); free tri-iodothyronine (FT3); fumarylacetoacetase; galactose/gal-1-phosphate; galactose-1-phosphate uridylyltransferase; gentamicin; glucose-6-phosphate dehydrogenase; glutathione; glutathione peroxidase; glycocholic acid; glycosylated hemoglobin; halofantrine; hemoglobin variants; hexosaminidase A; human erythrocyte carbonic anhydrase I; 17 alpha-hydroxyprogesterone; hypoxanthine phosphoribosyl transferase; immunoreactive trypsin; lactate; lead; lipoproteins ((a), B/A-1, β); lysozyme; mefloquine; netilmicin; oxygen; phenobarbitone; phenytoin; phytanic/pristanic acid; progesterone; prolactin; prolidase; purine nucleoside phosphorylase; quinine; reverse tri-iodothyronine (rT3); selenium; serum pancreatic lipase; sissomicin; somatomedin C; specific antibodies (adenovirus, anti-nuclear antibody, anti-zeta antibody, arbovirus, Aujeszky's disease virus, dengue virus, *Dra-cunculus medinensis*, *Echinococcus granulosus*, *Entamoeba histolytica*, enterovirus, *Giardia duodenalis*, *Helicobacter pylori*, hepatitis B virus, herpes virus, HIV-1, IgE (atopic disease), influenza virus, *Leishmania donovani*, leptospira, measles/mumps/rubella, *Mycobacterium leprae*, *Mycoplasma pneumoniae*, *Myoglobin*, *Onchocerca volvulus*, parainfluenza virus, *Plasmodium falciparum*, poliovirus, *Pseudomonas aeruginosa*, pH, respiratory syncytial virus,

rickettsia (scrub typhus), *Schistosoma mansoni*, *Toxoplasma gondii*, *Treponema pallidum*, *Trypanosoma cruzi/rangeli*, vesicular stomatis virus, *Wuchereria bancrofti*, yellow fever virus; specific antigens (hepatitis B virus, HIV-1); succinylacetone; sulfadoxine; theophylline; thyrotropin (TSH); thyroxine (T4); thyroxine-binding globulin; trace elements; transferrin; UDP-galactose-4-epimerase; urea; uroporphyrinogen I synthase; vitamin A; white blood cells; and zinc protoporphyrin. Salts, sugar, protein, fat, vitamins and hormones naturally occurring in blood or interstitial fluids may also constitute analytes in certain embodiments. The analyte may be naturally present in the biological fluid, for example, a metabolic product, a hormone, an antigen, an antibody, and the like. Alternatively, the analyte may be introduced into the body, for example, a contrast agent for imaging, a radioisotope, a chemical agent, a fluorocarbon-based synthetic blood, or a drug or pharmaceutical composition, including but not limited to insulin; ethanol; cannabis (marijuana, tetrahydrocannabinol, hashish); inhalants (nitrous oxide, amyl nitrite, butyl nitrite, chlorohydrocarbons, hydrocarbons); cocaine (crack cocaine); stimulants (amphetamines, methamphetamines, Ritalin, Cylert, Preludin, Didrex, PreState, Voranil, Sandrex, Plegine); depressants (barbituates, methaqualone, tranquilizers such as Valium, Librium, Miltown, Serax, Equanil, Tranxene); hallucinogens (phencyclidine, lysergic acid, mescaline, peyote, psilocybin); narcotics (heroin, codeine, morphine, opium, meperidine, Percocet, Percodan, Tus-sionex, Fentanyl, Darvon, Talwin, Lomotil); designer drugs (analogs of fentanyl, meperidine, amphetamines, methamphetamines, and phencyclidine, for example, Ecstasy); anabolic steroids; and nicotine. The metabolic products of drugs and pharmaceutical compositions are also contemplated analytes. Analytes such as neurochemicals and other chemicals generated within the body may also be analyzed, such as, for example, ascorbic acid, uric acid, dopamine, noradrenaline, 3-methoxytyramine (3MT), 3,4-Dihydroxyphenylacetic acid (DOPAC), Homovanillic acid (HVA), 5-Hydroxytryptamine (5HT), and 5-Hydroxyindoleacetic acid (FHIAA).

**[0108]** By the terms “evaluated”, “monitored”, “analyzed”, and the like, it is meant that an analyte may be detected and/or measured.

**[0109]** The terms “sensor head” and “sensing region” as used herein are broad terms and are used in their ordinary sense, including, without limitation, the region of a monitoring device responsible for the detection of a particular analyte. In one embodiment, the sensing region generally comprises a non-conductive body, a working electrode (anode), a reference electrode, and a counter electrode (cathode) passing through and secured within the body forming an electrochemically reactive surface at one location on the body and an electronic connective means at another location on the body, and a multi-region membrane affixed to the body and covering the electrochemically reactive surface. The counter electrode generally has a greater electrochemically reactive surface area than the working electrode. During general operation of the sensor a biological sample (for example, blood or interstitial fluid) or a portion thereof contacts (directly or after passage through one or more membranes or domains) an enzyme (for example, glucose oxidase); the reaction of the biological sample (or portion thereof) results in the formation of reaction products that allow a determination of the analyte (e.g., glucose) level in the biological sample. In preferred embodiments, the multi-region membrane further comprises an enzyme domain and an electrolyte

phase, namely, a free-flowing liquid phase comprising an electrolyte-containing fluid described further below. While the preferred embodiments are generally illustrated by a sensor as described above, other sensor head configurations are also contemplated. While electrochemical sensors (including coulometric, voltammetric, and/or amperometric sensors) for the analysis of glucose are generally contemplated, other sensing mechanisms, including but not limited to optochemical sensors, biochemical sensors, electrocatalytic sensors, optical sensors, piezoelectric sensors, thermoelectric sensors, and acoustic sensors may be used. A device may include one sensing region, or multiple sensing regions. Each sensing region can be employed to determine the same or different analytes. The sensor region may include the entire surface of the device, a substantial portion of the surface of the device, or only a small portion of the surface of the device. Different sensing mechanisms may be employed by different sensor regions on the same device, or a device may include one or more sensor regions and also one or more regions for drug delivery, immunoisolation, cell transplantation, and the like. It may be noted that the preferred embodiments, the “sensor head” is the part of the sensor that houses the electrodes, while the “sensing region” includes the sensor head and area that surrounds the sensor head, particularly the area in such proximity to the sensor head that effects of the foreign body capsule on the sensor head.

**[0110]** The term “foreign body capsule” or “FBC,” as used herein, is a broad term and is used in its ordinary sense, including, without limitation, body’s response to the introduction of a foreign object; there are three main layers of a FBC: 1) the innermost layer, adjacent to the object, is composed generally of macrophages, foreign body giant cells, and occlusive cell layers; 2) the intermediate FBC layer, lying distal to the first layer with respect to the object, is a wide zone (e.g., about 30-100 microns) composed primarily of fibroblasts, contractile fibrous tissue fibrous matrix; and 3) the outermost FBC layer is loose connective granular tissue containing new blood vessels. Over time, this FBC tissue becomes muscular in nature and contracts around the foreign object so that the object remains tightly encapsulated.

**[0111]** The term “subcutaneous,” as used herein, is a broad term and is used in its ordinary sense, including, without limitation, under the skin.

**[0112]** The term “intramuscular,” as used herein, is a broad term and is used in its ordinary sense, including, without limitation, within the substance of a muscle.

**[0113]** The term “intraperitoneal,” as used herein, is a broad term and is used in its ordinary sense, including, without limitation, within the peritoneal cavity, which is the area that contains the abdominal organs.

**[0114]** The term “intrafascial,” as used herein, is a broad term and is used in its ordinary sense, including, without limitation, within the fascia, which is a sheet or band of fibrous tissue such as lies deep to the skin or forms an investment for muscles and various other organs of the body.

**[0115]** The term “axillary region,” as used herein, is a broad term and is used in its ordinary sense, including, without limitation, the pyramidal region between the upper thoracic wall and the arm, its base formed by the skin and apex bounded by the approximation of the clavicle, coracoid process, and first rib; it contains axillary vessels, the brachial plexus of nerves, many lymph nodes and vessels, and loose areolar tissue.

**[0116]** The term “apex,” as used herein, is a broad term and is used in its ordinary sense, including, without limitation, the uppermost point; for example the outermost point of a convexly curved portion.

**[0117]** The term “cuboidal,” as used herein, is a broad term and is used in its ordinary sense, including, without limitation, a polyhedron composed of six faces, eight vertices, and twelve edges, wherein the faces.

**[0118]** The term “convex,” as used herein, is a broad term and is used in its ordinary sense, including, without limitation, outwardly protuberant; that is, an object is convex if for any pair of points within the object, any point on the line that joins them is also within the object. A convex portion is a portion of an object that is convex in that portion of the object. For example, a solid cube is convex, but anything that is hollow or has a dent in it is not convex.

**[0119]** The term “curvature,” “curved portion,” and “curved,” as used herein, are broad terms and is used in their ordinary sense, including, without limitation, one or more arcs defined by one or more radii.

**[0120]** The term “cylindrical,” as used herein, is a broad term and is used in its ordinary sense, including, without limitation, a solid of circular or elliptical cross section in which the centers of the circles or ellipses all lie on a single line. A cylinder defines a lateral surface and two ends.

**[0121]** The term “ellipsoidal,” as used herein, is a broad term and is used in its ordinary sense, including, without limitation, closed surface of which all plane sections are either ellipses or circles. An ellipsoid is symmetrical about three mutually perpendicular axes that intersect at the center.

**[0122]** The term “spherical,” as used herein, is a broad term and is used in its ordinary sense, including, without limitation, a solid that is bounded by a surface consisting of all points at a given distance from a point constituting its center.

**[0123]** The term “anchoring material,” as used herein, is a broad term and is used in its ordinary sense, including, without limitation, biocompatible material that is non-smooth, and particularly comprises an architecture that supports tissue ingrowth in order to facilitate anchoring of the material into bodily tissue in vivo. Some examples of anchoring materials include polyester, polypropylene cloth, polytetrafluoroethylene felts, expanded polytetrafluoroethylene, and porous silicone, for example.

**[0124]** The term “mechanical anchoring mechanism,” as used herein, is a broad term and is used in its ordinary sense, including, without limitation, mechanical mechanisms (e.g., prongs, spines, barbs, wings, hooks, helical surface topography, gradually changing diameter, or the like), which aids in immobilizing the sensor in the subcutaneous space, particularly prior to formation of a mature foreign body capsule

**[0125]** The term “biocompatible,” as used herein, is a broad term and is used in its ordinary sense, including, without limitation, compatibility with living tissue or a living system by not being toxic.

**[0126]** The term “non-adhesive to tissue,” as used herein, is a broad term and is used in its ordinary sense, including, without limitation, a material or surface of a material to which cells and/or cell processes do not adhere at the molecular level, and/or to which cells and/or cell processes do not adhere to the surface of the material.

**[0127]** The term “plastic,” as used herein, is a broad term and is used in its ordinary sense, including, without limitation, polymeric materials that have the capability of being molded or shaped, usually by the application of heat and

pressure. Polymers that are classified as plastics can be divided into two major categories: thermoplastic and thermoset.

**[0128]** The term “thermoplastic,” as used herein, is a broad term and is used in its ordinary sense, including, without limitation, polymeric materials such as polyethylene and polystyrene that are capable of being molded and remolded repeatedly. The polymer structure associated with thermoplastics is that of individual molecules that are separate from one another and flow past one another.

**[0129]** The term “thermoset,” as used herein, is a broad term and is used in its ordinary sense, including, without limitation, polymeric materials such as epoxy, silicone, and polyurethane that cannot be reprocessed upon reheating. During their initial processing, thermosetting resins undergo a chemical reaction that results in an infusible, insoluble network. Essentially, the entire heated, finished article becomes one large molecule. For example, the epoxy polymer undergoes a cross-linking reaction when it is molded at a high temperature. Subsequent application of heat does not soften the material to the point where it can be reworked and indeed may serve only to break it down.

**[0130]** The term “substantially,” as used herein, is a broad term and is used in its ordinary sense, including, without limitation, refers to an amount greater than 50 percent, preferably greater than 75 percent and, most preferably, greater than 90 percent.

**[0131]** The term “host,” as used herein is a broad term and is used in its ordinary sense, including, without limitation, both humans and animals.

**[0132]** The term “R-value,” as used herein, is a broad term and is used in its ordinary sense, including, without limitation, one conventional way of summarizing the correlation of data; that is, a statement of what residuals (e.g., root mean square deviations) are to be expected if the data are fitted to a straight line by the a regression.

#### Overview

**[0133]** In a preferred embodiment, the sensor heads, devices, and methods of the preferred embodiments may be used to determine the level of glucose or other analytes in a host. The level of glucose is a particularly important measurement for individuals having diabetes in that effective treatment depends on the accuracy of this measurement.

**[0134]** Although the description that follows is primarily directed at implantable glucose sensors, the methods of the preferred embodiments are not limited to either electrochemical sensing or glucose measurement. Rather, the methods may be applied to any implantable sensor that detects and quantifies an analyte present in biological fluids (including, but not limited to, amino acids and lactate), including those analytes that are substrates for oxidase enzymes (see, e.g., U.S. Pat. No. 4,703,756 to Gough et al., hereby incorporated by reference), as well as to implantable sensors that detect and quantify analytes present in biological fluids by analytical methods other than electrochemical methods, as described above. The methods may also offer benefits and be suitable for use with implantable devices, other than sensors, that are concerned with the transport of analytes, for example, drug delivery devices, cell transplantation devices, tracking devices, or any other foreign body implanted subcutaneously or in other soft tissue of the body, for example, intramuscular, intraperitoneal, intrafascial, or in the axial region.



**[0135]** Methods and devices that may be suitable for use in conjunction with aspects of the preferred embodiments are disclosed in copending applications including U.S. application Ser. No. 09/916,386 filed Jul. 27, 2001 and entitled "MEMBRANE FOR USE WITH IMPLANTABLE DEVICES"; U.S. application Ser. No. 09/916,711 filed Jul. 27, 2001 and entitled "SENSOR HEAD FOR USE WITH IMPLANTABLE DEVICE"; U.S. application Ser. No. 09/447,227 filed Nov. 22, 1999 and entitled "DEVICE AND METHOD FOR DETERMINING ANALYTE LEVELS"; U.S. application Ser. No. 10/153,356 filed May 22, 2002 and entitled "TECHNIQUES TO IMPROVE POLYURETHANE MEMBRANES FOR IMPLANTABLE GLUCOSE SENSORS"; U.S. application Ser. No. 09/489,588 filed Jan. 21, 2000 and entitled "DEVICE AND METHOD FOR DETERMINING ANALYTE LEVELS"; U.S. application Ser. No. 09/636,369 filed Aug. 11, 2000 and entitled "SYSTEMS AND METHODS FOR REMOTE MONITORING AND MODULATION OF MEDICAL DEVICES"; and U.S. application Ser. No. 09/916,858 filed Jul. 27, 2001 and entitled "DEVICE AND METHOD FOR DETERMINING ANALYTE LEVELS," as well as issued patents including U.S. Pat. No. 6,001,067 issued Dec. 14, 1999 and entitled "DEVICE AND METHOD FOR DETERMINING ANALYTE LEVELS"; U.S. Pat. No. 4,994,167 issued Feb. 19, 1991 and entitled "BIOLOGICAL FLUID MEASURING DEVICE"; and U.S. Pat. No. 4,757,022 filed Jul. 12, 1988 and entitled "BIOLOGICAL FLUID MEASURING DEVICE." All of the above patents and patent applications are incorporated in their entirety herein by reference.

**[0136]** Such medical devices, including implanted analyte sensors, drug delivery devices and cell transplantation devices require close vascularization and transport of solutes across the device-tissue interface for proper function. These devices generally include a biointerface membrane, which encases the device or a portion of the device to prevent access by host inflammatory cells, immune cells, or soluble factors to sensitive regions of the device.

#### Nature of the Foreign Body Capsule

**[0137]** Biointerface membranes stimulate a local inflammatory response, called the foreign body response (FBR) that has long been recognized as limiting the function of implanted devices that require solute transport. The FBR has been well described in the literature.

**[0138]** FIG. 1 is a schematic drawing that illustrates a classical foreign body response (FBR) to an object implanted under the skin. There are three main regions of a FBR. The innermost FBR region **12**, adjacent to the device, is composed generally of macrophages and foreign body giant cells **14** (herein referred to as the barrier cell layer). These cells form a monolayer of closely opposed cells over the entire surface of a microscopically smooth, macroscopically smooth (but microscopically rough), or microporous (i.e., less than about 1  $\mu\text{m}$  pore size) membrane. The intermediate FBR region **16** (herein referred to as the fibrous zone), lying distal to the first region with respect to the device, is a wide zone (about 30-1000 microns) composed primarily of fibroblasts **18**, contractile fibrous tissue **19**, and fibrous matrix **20** (shown as empty space, which is actually filled with this fibrous matrix). It may be noted that the organization of the fibrous zone, and particularly the contractile fibrous tissue **19**, contributes to the formation of the monolayer of closely opposed cells due to the contractile forces **21** around the surface of the foreign

body (e.g., membrane **10**). The outermost FBR region **22** is loose connective granular tissue containing new blood vessels **24** (herein referred to as the vascular zone). Over time, the foreign body capsule becomes muscular due to differentiation of fibroblasts into myofibroblasts and contracts around the foreign body so that the foreign body remains tightly encapsulated.

#### Sensor Geometry

**[0139]** It has been observed that the variability of function observed in implanted sensors may sometimes occur in several different devices implanted within the same host (e.g., human or animal). Accordingly, this observation suggests that individual variability of hosts may not be a significant factor in the observed variability. Data suggest that a major factor in the variability is the individual nature of how the surrounding tissue heals around each device. Accordingly, the present invention discloses methods and systems for selecting an appropriate geometry for a device that requires transport of analytes in vivo, such that the healing of the host tissue around the device is optimized. Optimizing the host response includes minimizing variability, increasing transport of analytes, and controlling motion artifact in vivo, for example.

**[0140]** FIG. 2A is schematic side view of a prior art device that has a sensing region with an abrupt inside turn, causing sub-optimal foreign body response. FIG. 2B is a photomicrograph of the type of device of FIG. 2A after formation of the foreign body capsule and subsequent explantation, showing thickened host response adjacent the abrupt inside turn and lymphocytic infiltrate.

**[0141]** Particularly, FIG. 2A depicts a sensor **26** wherein a dome sensor head **28** incorporating the sensing electrodes **30** or other sensing devices or means protrudes above a large, flat surface **32** of the device. Particularly noteworthy is the abrupt change in curvature of an approximately 90-degree turn between the sensor head **28** and the flat surface **32**. Additionally, an O-ring **34** encircles the device to hold a biointerface membrane (not shown) over the dome sensor head **28** of the device and causes further discontinuity of the surface between the sensor head and the flat surface of the sensor body.

**[0142]** A wide variability in the healing of the tissue adjacent to the sensor dome of the device is observed. Particularly, the foreign body capsule is thickest in the area **42** adjacent to the discontinuous surface (e.g., O-ring and sensor head-sensor body interface). This thickest portion is a result of tissue contracture that occurs during the foreign body response, resulting in forces being applied to the portion of the device interfacing with the tissue. Notably, because the device of FIG. 2A has an inside turn where the dome meets the top plate at the O-ring, the forces **40** exerted by contracture pull outward, and thus away from the device-tissue interface. This causes inflammation in the region of the inside turn. Greater tissue trauma and the formation of barrier cell layers are typically observed adjacent to the region of the device wherein the dome meets the top plate. It is believed that outward forces produced by tissue contraction cause wounding in this site, which stimulates higher levels of inflammation, resulting in occlusion. It should be noted that this more "turbulent area" **42** is marked by an increase chronic inflammatory response which is most occlusive at the discontinuous

surface are, but spreads to include the thickening in sensing area **41** that may effect the transport of analytes and thus the function of the sensor in vivo.

**[0143]** FIG. 2B is a photomicrograph of the foreign body capsule, after a device having the sensor configuration of FIG. 2A was explanted from a host. The right side of the photomicrograph shows a thickening of the tissue response with inflammatory cells present near the inside turn (within **44**). The o-ring **34** was located approximately as shown by the dashed line, which contributed to the thickening of the tissue response due to the abruptness of the surface area. It may be noted that the tissue response thins near the center of the dome (at **46** (the fold in the section near the center of the dome is an artifact of sample preparation)). The electrodes are located within the sensing region **47** as shown on the photomicrograph, over which occlusive cells extend from the thickened response **44**. That is, the thickening of the tissues in the “turbulent area”, which is the area adjacent to the discontinuous surfaces at the inside turn, leads to the subsequent formation of barrier cell layers that may continue over the sensor head and block the transport of analytes across the device-tissue interface over time. The nature of the response suggests that trauma to the tissue may have occurred during or after the initial wound healing. If trauma occurs during wound healing, complete healing never occurs and the tissue stays in a hyper-inflammatory state during the entire course of the implant period. Alternatively, if trauma occurs subsequent to the initial wound healing, the wound heals but is re-injured, perhaps repeatedly, over time. Either of these trauma-induced wounding mechanisms may lead to improper healing and the growth of occlusive cells at the biointerface. It may be noted that it is the combination of the severity of the inside turn and its proximity to the sensing region that forms the occlusive cell layer, which may cause blockage of analyte transport to the sensor. In some alternative embodiments, certain turns (e.g., inside turns or otherwise) on the surface of the sensor body may not adversely effect the transport of analytes; for example, turns that are located at a sufficient distance from the sensing region may not produce a thickened inflammatory host response adjacent the sensing region and/or turns that are sufficiently gradual and/or lack abruptness may not adversely effect the host response adjacent the sensing regions.

**[0144]** The tissue response resulting in the growth of occlusive cells as described above tends to occur due to the contraction of the surrounding wound tissue. It is therefore desirable to ensure stable wound healing that does not change after the initial healing. As illustrated by the photomicrograph of FIG. 2B, the geometry of the device depicted does not favor stable healing because tissue contracture results in the pulling away of tissues from the device surface at the junction between the dome and top plate.

**[0145]** FIG. 3A is a schematic side view of another prior art device that has flattened surfaces across the entire device, and particularly across the sensing region, creating sub-optimal foreign body capsule healing. In the sensor of FIG. 3A, all surfaces are flat and all edges and corners are sharp; there is no curvature or convexity, particularly in the sensing region.

**[0146]** Consequently, contractile forces **54** pull laterally and outwardly along the flat surfaces, including the sensing region, which is the area proximal to the electrodes **52**, as the FBC tightens around the device. Lateral contractile forces **54** caused by the FBC **50** along the flat surfaces are believed increase motion artifact and tissue damage due to shear forces **56** between the device **52** and the tissue. In other words, rather

than firmly holding the tissue adjacent the sensing region with a downward force against the sensing region (such as will be shown with the geometry of the present invention), a lateral movement (indicated by arrow **56**) is seen in the tissue adjacent to the sensing region, causing trauma-induced wounding mechanisms that may lead to improper healing and the growth of occlusive cells at the biointerface. This is especially harmful in the sensing region, which requires substantially consistent transport of analytes, because it is known that thickening of the FBC from chronic inflammation and occlusive cells decreases or blocks analyte transport to the device.

**[0147]** It may be noted that some prior art devices attempt to minimize tissue trauma by rounding edges and corners, however the effects of tissue trauma will still be seen in the flat surfaces (e.g., sensing region) of the device such as described above, thereby at least partially precluding function of a device requiring analyte transport. Similarly, placement of the sensing region, or a plurality of sensing regions, away from the center of the device (such as seen in some prior art devices) would not significantly improve the effects of the lateral contractile forces along the flat surface of the sensing region(s), because it is the flat surface, whether at the center and/or off center, that causes in the occlusive tissue trauma in vivo.

**[0148]** It may be noted that the thickness of the FBC appears to increase around the central portion of the device and be thinner around the ends. It is believed that this phenomenon is due to the loose and counteracting lateral contractile forces near the center of the device, while a tighter contractile force near the ends of the device indicates tighter control of the FBC.

**[0149]** FIG. 3B is a schematic side view of the sensing region of yet another prior art device that has flattened surfaces across the device, however includes an inset sensing region. The device of FIG. 3B is similar to the device of FIG. 3A, and is another example of a disadvantageous device due to sub-optimal foreign body capsule healing. Particularly, the inset portion **58**, whether bounded by sharp or rounded edges, will cause contractile forces **54** of the foreign body capsule to pull outwardly and laterally. The inset region of the device will experience increased trauma-induced wounding mechanisms that may lead to improper healing and the growth of occlusive cells at the biointerface as compared to FIG. 3A. In other words, both flat and inset (e.g., concave) sensing regions will cause tissue wounding and chronic inflammatory response leading to decreased transport of analytes, increased time lag, and decreased device function.

**[0150]** In contrast to the prior art, a preferred embodiment of the present invention provides a sensor geometry that includes a sensing region adapted for transport of analytes between the sensor and the bodily fluid, wherein the sensing region is located on a curved portion of the sensor body such that when a foreign body capsule forms around the sensor, a contractile force is exerted by the foreign body capsule toward the sensing region. This contractile force provides sufficient support to maintain the foreign body capsule in close proximity to the sensing region without substantial motion artifact or shearing forces, thereby minimizing inflammatory trauma, minimizing the thickness of the foreign body capsule, and maximizing the transport of analytes through the foreign body capsule. Additionally, the overall design described herein ensures more stable wound healing, and therefore better acceptance in the body.

**[0151]** It may be noted that the disadvantageous outward forces (e.g., forces **40** as described with reference to FIG. 2A, and forces **54** such as described with reference to FIG. 3B) refer to forces that cause motion of the foreign body capsule relative to the device as a whole. In other words, the discontinuity of the surface on which the sensing region is located creates outward forces of the FBC as a whole, which unfortunately allows motion of the device within the FBC. These outside forces **40** create a thickened FBC due to chronic inflammatory response responsive to motion of the device within the FBC such as described with reference to FIGS. 2 and 3. It may be noted however that a biointerface material with interconnected cavities in at least a portion thereof may be placed over the sensor head such as described with reference to copending U.S. patent application Ser. No. 10/647,065 filed Aug. 22, 2003 and entitled "POROUS MEMBRANE FOR USE WITH IMPLANTABLE DEVICES", which is incorporated herein in its entirety by reference. This biointerface material advantageously causes disruption of the contractile forces caused by the fibrous tissue of the FBC within the cavities of the biointerface material. Particularly, the biointerface material includes interconnected cavities with a multiple-cavity depth, which may affect the tissue contracture that typically occurs around a foreign body. That is, within the cavities of the biointerface material, forces from the foreign body response contract around the solid portions that define the cavities and away from the device. This architecture of the interconnected cavities of the biointerface material is advantageous because the contractile forces caused by the downward tissue contracture that may otherwise cause cells to flatten against the device and occlude the transport of analytes, is instead translated to and/or counteracted by the forces that contract around the solid portions (e.g., throughout the interconnected cavities) away from the device. Therefore, the mechanisms of the present invention (e.g., geometric configurations described herein) are designed to increase downward forces on the sensor head in order to decrease motion of the device relative to the FBC as a whole, which complements the mechanisms of the biointerface material that causes disruption of the contractile forces within the biointerface material in order to deflect the forces toward the solid portions within the biointerface and away from the device itself, both of which mechanisms work to prevent the formation of occlusive cells that block analyte transport. Therefore, a biointerface material such as described above may be placed over at least a portion (e.g., some or all) of the sensing region of the devices of the present invention to aid in preventing the formation of occlusive cells (e.g., barrier cell layer) and increasing the transport of analytes.

**[0152]** FIG. 4 is a cross-sectional view of the sensing region of an analyte sensor in one embodiment, wherein the sensing region is continuously curved, thereby causing contractile forces from the foreign body capsule to press downward thereon. The sensing region is located on an end of sensor that extends longitudinally (not shown). Particularly, the curved sensor region **70** includes no abrupt edges or discontinuous surfaces to ensure stable wound healing. For example, such a device **68** may be cylindrical with a collet that meets the head, as depicted in FIG. 4. The collet produces a continuous curvature from the sensor dome **72** to the wall of the cylinder **73**. When this design is employed, tissue contracture (depicted by the arrows **74**) results in forces oriented in towards the device interface along the entire surface of the dome (depicted by arrows **76**). Thus, the foreign body capsule is pulled down

against the surface of the device. Injury and re-injury is thereby minimized or even prevented because there are no outward forces produced by tissue contracture as in the design depicted in the devices of FIGS. 2 and 3. Improved biointerface healing is observed for this geometry, as evidenced by improved in vivo performance. A device with a design similar to that depicted in FIG. 4 was the subject of animal testing, which is described in more detail with reference to FIGS. 11A and 11B.

**[0153]** FIG. 5A is a perspective view of an analyte sensor in another embodiment, including a thin ellipsoidal geometry, a curved sensing region, and an overall curved surface on which the sensing region is located, thereby causing contractile forces from the foreign body capsule to press downward on the sensor head. FIG. 5B is the analyte sensor of FIG. 5A shown implanted with the sensing region adjacent to the muscle fascia underlying the subcutaneous space. FIG. 5C is an end view of the analyte sensor of FIG. 5A showing the contractile forces that would be caused by a foreign body capsule. FIG. 5D is a side view of the analyte sensor of FIG. 5A.

**[0154]** In this embodiment, the analyte sensor **80** includes the sensing region **82** located on a curved portion of the sensor body, and including no abrupt edge or discontinuous surface in the proximity of the sensing region. Additionally, the overall curvature of the surface on which the sensing region is located, including rounded edges, invokes a generally uniform FBC around that surface, decreasing inflammatory response and increasing analyte transport at the device-tissue interface **84**.

**[0155]** In one aspect of this embodiment, the sensor geometry particularly suited for healing at the device-tissue interface **84** when the sensor is implanted between two tissue planes. That is, the geometry includes a thin, substantially oval sensor, wherein the sensor head is positioned on one of the major surfaces of the sensor rather than at the tip, as illustrated in FIG. 4. When implanted, the sensor is oriented such that the sensor head is adjacent to the fascia underlying the subcutaneous space.

**[0156]** Perpendicular forces **88**, depicted in FIG. 5C by arrows pointing down, reduce or eliminate shear forces with the tissue at the sensor head. While lateral forces **90** may appear to create shear forces at the sensor head, several features of the sensor mitigate these forces. For example, the sensor is much thinner and is immediately adjacent to the fascia, underlying the fat, making it less prone to movement. As another example, the sensor may be sutured to the tough fascia, which further prevents lateral forces from being conveyed to the sensor head; while in other preferred embodiments, an anchoring material or other method of attachment may be employed. As yet another example, in order to facilitate proper healing, the side of the sensor upon which the sensor head is situated preferably has a curved radius extending from lateral side to lateral side. As depicted in the side view and end view (FIGS. 5C and 5D), the sensor head is positioned at the apex of the radius. When surrounding tissue contracts as it heals, the radius serves to optimize the forces **88** exerted down onto the curved surface, especially the forces in the lateral directions **90**, to keep the tissue uniformly in contact with the surface and to produce a thinner foreign body capsule. The curvature ensures that the head is resting against the tissue and that when tissue contraction occurs, forces are generated downward on the head so that the tissue attachment is maintained. It may be noted that the downward forces bring

the tissue into contact with porous biointerface materials used for ingrowth-mediated attachment and for biointerface optimization, such as described above and in copending U.S. patent application Ser. No. 10/647,065 filed Aug. 22, 2003 and entitled "POROUS MEMBRANE FOR USE WITH IMPLANTABLE DEVICES". While it is preferable to have a curved radius extending longitudinally, in certain embodiments it may be acceptable to incorporate a longitudinally flat surface or longitudinal surface with another configuration. In a device as depicted in FIG. 5C, the radius of curvature in the lateral direction is preferably about 2.7 cm.

[0157] It may be noted that any curved surface can be deconvoluted to a series of radii, as is appreciated by one skilled in the art. It is generally preferred to have a radius of curvature in the lateral, longitudinal or other direction of from about 0.5 mm or less to about 10 cm or more. More preferably the radius of curvature is from about 1, 2, 3, 4, 5, 6, 7, 8, or 9 mm to about 5, 6, 7, 8, or 9 cm, even more preferably the radius of curvature is from about 1, 1.25, 1.5, 1.75, 2 or 2.25 cm to about 3, 3.25, 3.5, 3.75, 4, 4.25, 4.5, or 4.75 cm, and most preferably the radius of curvature is from about 2.5 or 2.6 cm to about 2.7, 2.8, or 2.9 cm. Radii of curvature in the longitudinal direction are generally preferred to be larger than those in the lateral direction. However, in certain embodiments the radii of curvature may be approximately the same, or smaller in the longitudinal direction.

[0158] In one embodiment, the preferred shape of the device can be defined in the context of a reference plane. In such an embodiment, the device has a first major surface and a second major surface opposite the first major surface, where the first major surface includes a sensor. The first and second major surfaces together preferably account for at least about 40% or 50% of the surface area of the device. The first major surface has edges between which a width of the first major surface can be measured, and the sensor is preferably spaced away from the edges by a distance that is at least about 10% of the width, and preferably at least about 15%, 20%, 25%, or 30% of the width of the first major surface. It is understood that the first major surface may have multiple edges and that multiple widths can be measured, and in the context of the foregoing, a width should be configured to run from one edge to an opposite edge. Preferably, spacing of the sensor from the edges specified above is true for at least two width measurements, which measurements are taken generally transverse to each other.

[0159] With the sensor situated on the first major surface of the device, a reference plane can be imagined that is congruent to the first major surface, which first major surface is preferably at least slightly convex. This plane, which would then touch the first major surface at a point spaced in from the edges of the first major surface, would be generally parallel to the first major surface and would additionally be spaced away from opposite edges of the first major surface due to the convex nature of the first major surface. In preferred embodiments, the reference plane would be spaced from the edges a distance that is at least about 3%, 4%, or 5% of the width between those edges, and more preferably 6%, 7%, 8% or more from the edges, but at the same time the distance is preferably not more than 50%, 40%, or 30% of the width, and may well be not more than 25%, 20%, or 15% of the width between the edges. In preferred embodiments, the edges of the first major surface are rounded, so that they transition smoothly away from the first major surface. In this situation, the location of the edge can be configured to be the point at

which a congruent line and/or a normal line would be angled 45 degrees with respect to the reference plane.

[0160] In preferred embodiments, the sensor body defines a surface area, and wherein between 10% and 100% of the surface area is convexly curved. In some preferred embodiments a substantial portion of the surface area is convexly curved. In one preferred embodiment, at least about 90% of the surface area is convexly curved. In other preferred embodiments, 10, 20, 30, 40, 50, 60, 70, 80, 90, or 100% of the surface area is curved.

[0161] FIG. 6 is a perspective view of a sensor geometry in an alternative embodiment wherein the sensor includes a curved sensor region and a flat region, wherein the interface between the flat region and the curved region includes a gradual transition. The implantable sensor includes a major surface **100** with a curved portion **102** on which the sensing region **101** is located and a flat portion **104** adjacent to the curved portion **102**. Although the major surface is not entirely curved in this embodiment, the interface **103** between the curved and flat portions has a gradual transition and is located sufficiently distal from the sensing region **101** (where the transport of analytes is required) that any chronic inflammation caused by the turn at the interface **103** will not likely translate to the sensing region **101**. In other words, the contractile forces **106** from a foreign body capsule that forms around the sensor in vivo will tend to contract toward the sensing region **101**; although some outward and lateral forces are seen at the interface **103** and flat surface **104**, they are spaced sufficiently far from the sensing region such that any chronic inflammatory response will not likely cover the sensing region **101** and block analyte transport. Anchoring material may cover some part or the majority of the major surface **100**, may encircle the circumference of the sensor body **107**, and/or may cover some part or the entire surface **108** opposite the sensing region, such as described in more detail elsewhere herein.

[0162] FIG. 7 is a perspective view of a sensor geometry in an alternative embodiment wherein the entire sensor body is curved. The implantable sensor has a curvature over the entire surface area of the sensor body **110**. The curvature includes a variety of different radii at varying locations of the sensor body, and the contractile forces **112** from a FBC that forms around the sensor in vivo will tend to contract toward the entire sensor body **110**, including the sensing region **114** on a first major side **116**. Accordingly, this embodiment optimizes foreign body healing by minimizing the chronic inflammatory response that is otherwise caused by motion within the FBC. In other words, the FBC holds tightly to the sensor body **110** to provide optimal control (e.g., minimal motion) of the tissues around the sensor geometry, and particularly around the sensing region **112**. It may be noted that the second major side **118** has a slight curvature that allows the entire sensor body to be curved. However in some embodiments, the second major side **118** can be designed flat rather than curved; in these embodiments, it may be noted that the sensing region is located on the side opposite the flat surface and there is no concavity therein or thereon. Anchoring material may cover some part or a majority of the first major side **116**, may encircle the circumference of the sensor body **117**, and/or may cover some part or the entire second major side **118** opposite the sensing region.

[0163] FIG. 8 is a perspective view of a sensor **120** in an alternative embodiment including a cylindrical geometry wherein a plurality of sensors **124** are located on the curved

lateral surface **122** of the sensor body. Anchoring material (not shown) may cover at least some of the non-electrode surface area of the cylindrical body. The sensor of this embodiment takes advantage of numerous features described herein, including, but not limited to, the following advantages.

**[0164]** As a first noted advantage, the cylindrical geometry of the sensor body **120** allows for discreet placement within or between tissue types when the overall surface area-to-volume ratio can be optimized to provide a maximal surface area with a minimal volume. That is, although the volume of a sensor often depends on the necessary electronics within the sensor body, the evolution of smaller batteries and circuit boards sanctions the design and manufacture of a cylindrical sensor with minimal volume; simultaneously, the surface area inherent in a cylindrical geometry allows for maximal tissue anchoring in vivo (e.g., as compared to a substantially rectangular or oval structure). In one exemplary embodiment, an application specific integrated circuit (ASIC) may be designed to fit within the geometric design of any of the embodiments disclosed herein to maximize the electronic capabilities while minimizing volume requirements as compared to conventional circuit boards. Sensor electronics requirements vary depend on the sensor type, however one example of electronics for a glucose sensor is described in more detail with reference to copending U.S. patent application Ser. No. 10/633,367 filed on Aug. 1, 2003 and entitled "SYSTEM AND METHODS FOR PROCESSING ANALYTE SENSOR DATA," which is incorporated by reference herein in its entirety.

**[0165]** As a second noted advantage, the curved lateral surface **122** of the cylindrical structure lends itself to a plurality of sensing regions **124** (e.g., electrodes) and allows the sensor to sense a variety of different constituents (e.g., glucose, oxygen, interferants (e.g., ascorbate, urate, etc.)) using one compact sensor body.

**[0166]** As a third noted advantage, when the plurality of sensing regions **124** are configured to sense the same constituent (e.g., glucose) such as shown in FIG. **8**, and are spread apart such as shown in FIG. **8**, the likelihood of sensor location adjacent an area of the FBC that is optimized for transport of analytes is increased by the amount of increase of the area of the sensing regions **124**. For example, inflammatory host response sometimes forms unevenly, therefore a distribution and increased surface area of sensing region(s) increases the likelihood of placement of the sensing region adjacent an area of minimum inflammatory host response and maximum transport of analytes to the sensor.

**[0167]** As a fourth noted advantage, the FBC that forms around the lateral curved surface **122** will create generally uniform forces **126** toward the sensing region **124** and around the entire lateral surface. Furthermore, when the ends **128** of the cylindrical sensor body **120** are designed with a curvature such as shown in the embodiment of FIG. **8**, minimal chronic inflammatory foreign body response, and further induce a firm, substantially motion-free hold of the sensor body **120** within the host.

**[0168]** FIG. **9A** is a perspective view of a sensor geometry in an alternative embodiment including a substantially spherical body. The spherical sensor body **130a** has a plurality of sensing regions **132a** that encircle the body. However, in some alternative embodiments one or more sensing regions may be provided in a collective location or spread across the surface area of the sphere. Anchoring material is placed on or

around the sensor body; for example, the anchoring material **136a** may encircle the body in a manner similar to that of the sensing regions **132a**. The embodiment of FIG. **9** takes advantage of numerous features described herein, including, but not limited to, the following advantages.

**[0169]** As a first noted advantage, a spherical geometry defines an optimal surface-to-volume ratio when compared to other geometries of devices with a comparable volume (e.g., rectangular, oval, and cylindrical). That is, when volume is a constant, the spherical geometry will provide an optimal surface area for tissue ingrowth in vivo in combination with an optimal curvature for uniform contractile forces from a FBC in vivo as compared to other geometries.

**[0170]** As a second noted advantage, entirely curved surface area of the spherical geometry lends itself to a plurality of sensing regions (e.g., electrodes) **132a** and allows the sensor to sense a variety of different constituents (e.g., glucose, oxygen, interferants (e.g., ascorbate, urate, etc.)) using one compact sensor body **130a**.

**[0171]** As a third noted advantage, when a plurality of sensing regions **132a** that sense the same constituent (e.g., glucose) are spread apart, the likelihood of finding an area of the FBC that is optimized for transport of analytes is increased by the amount of increase of the area of the sensing regions.

**[0172]** As a fourth noted advantage, the FBC that forms around the spherical sensor body will create uniform forces **134a** toward the entire surface area, including the sensing regions **132a**, which may therefore be located anywhere on the sensor body. Consequently in vivo, a sensor body with a curvature such as shown in the embodiment of FIG. **9A** will induce minimal chronic inflammatory foreign body response, and further induce a firm, substantially motion-free hold of the sensor body within the host.

**[0173]** FIG. **9B** is a perspective view of a sensor geometry in an alternative embodiment including a substantially spherical body with a rod extending therefrom. The spherical sensing body **130b** has a plurality of sensing regions **132b** and anchoring material **136b** that encircle (or may be otherwise located on) the body such as described with reference to FIG. **9A**. However, in contrast to the embodiment of FIG. **9A**, a rod **138** is connected to the spherical body **130b** and houses some or all of the sensor electronics, which are described with reference to FIG. **8**. The embodiment of FIG. **9B** takes advantage of numerous features described herein, including those advantages described with reference to FIG. **9A**, and further includes the following advantages.

**[0174]** The separation of at least some of the electronics between the sensing body which houses the electrodes, from the rod which may house, for example a cylindrical battery, allows for optimization of the sensing body design by minimizing the volume and/or mass requirements of the sensing body **130b** due electronics. The geometric design of the sphere and rod as shown in FIG. **9B** enables good formation of a FBC because all surfaces, particularly on the sensing body **130b** are curved, and there are not abrupt or flat turns or edges; that is, the contractile forces created by the FBC will be exerted generally uniformly toward at least the sensing body, and notably toward the sensing region **132b**. Additionally, the sensing regions **132b** are optimally located on a curved area that can be designed with maximum surface area and minimum mass and/or volume (e.g., some or all sensor electronics account for much of the mass and/or volume are located within the rod). It may be noted that in some alternative

embodiments, the rod is removably attachable to the sensing body in vivo such that the electronics and/or sensing body may be individually removed and replaced (e.g., via minimally invasive methods).

[0175] FIGS. 10A to 10D are perspective views of a sensor that has an expandable sensing body in one embodiment. FIGS. 10A and 10C are views of the sensor with the sensing body in a collapsed state, FIGS. 10B and 10D are views of the sensor with the sensing body in an expanded state. An expandable sensor 140 is advantageous in that it can be inserted into the subcutaneous space in a minimally invasive manner (e.g., through a catheter) in its collapsed state. It may be, for example, less than or equal to about 3 mm in diameter 142 and may be designed with a guide wire (not shown) extending through the sensor in some embodiments. Once it has been delivered into the appropriate site in vivo, the sensing body expands to an increased surface area.

[0176] The sensor 140 includes a sensing body 144 on which the sensing region 145 is located and an electronics body 146 in which the sensor electronics are located such as described with reference to FIG. 8. In alternative embodiments, some portion of the electronics may be housed within the sensing body. The sensing body 144 is formed from an elastomeric material and adapted for expansion using a liquid (e.g., saline or silicone oil). As an alternative, the sensing body 144 may be formed from a non-elastomeric material (e.g., polyethylene terephthalate) and folded for insertion using a catheter (not shown). As another alternative, the sensing body can be formed from nitinol, or the like, which may be advantageous due to its ability to self-expand and memorize its shape long term. In some embodiments, the expandable sensing body is adapted to fill a particular subcutaneous pocket without leaving spaces in the subcutaneous space and without causing pressure necrosis. In one example a metal framework may be used to hold the sensing body in its expanded state. The sensing region 145 includes electrodes, which are connected to the electronics body via a flexible wire or the like (not shown). Anchoring material 148 encircles (or is otherwise located on) the sensing body 144 in order to anchor the sensing body stably in vivo. The sensor electronics portion may be formed with or without a curvature, with or without anchoring material, and with or without particular concern for its effect on the foreign body capsule in vivo as it relates to the sensing body. Additional advantages of this embodiment correspond to the advantages described with reference to FIG. 9B due to its substantially similar configuration in its expanded state.

[0177] FIGS. 11A to 11D are perspective views of sensors wherein one or more sensing bodies are tethered to an electronics body in a variety of alternative embodiments. In each of the embodiments, the sensor 150 includes a sensing body 152 with a sensing region 153 located on a curved portion of the sensing body 152 such that when a foreign body capsule forms around the sensing body 152, the foreign body capsule exerts a contractile force toward the sensing region 153 as described elsewhere herein. Anchoring material 154 is located on at least a portion of the sensing body 152 in any known manner such as described elsewhere herein. Furthermore, in each of these embodiments, the electronics body 156 may include the majority of the mass of the sensor 150, which is remote from the sensing body 152. The electronics body 156 is connected to the sensing body 152 via a tether 158, which may have a variety of configurations such as described herein. As an alternative to the tether, the electronics body 156

may be connected to the sensing body 152 via a wireless RF connection (not shown) such that the electronics body 156 and the sensing body 152 may be separately implanted, explanted, monitored, and/or replaced. It may be noted that in an embodiment that utilizes RF transmission to connect the sensing body to the electronics body, some electronics are housed in the sensing body 152 to enable measurement and transmission of sensor information. Additionally, in some alternative embodiments of the tethered sensor, at least some of the electronics are housed within the sensing body.

[0178] In these embodiments wherein the sensing body 152 is tethered to the electronics body 156, the sensing body 152 can be easily optimized for surface area, shape, size, geometry, mass, density, volume, surface area-to-volume, surface area-to-density, and surface area-to-mass as desired. That is, without the mass, size, and volume constraints normally imposed by the electronics portion of a sensor, the sensing body can be optimally designed for a particular implantation site, function, or other parameter. Additionally, the electronics body can be formed from any biocompatible material (e.g., metal, ceramic, or plastic) known in the art. Additionally, it may be hermetically sealed to protect the electronic components. The tether 158 may be formed from a polymeric material or other biocompatible material and encases a conductive wire (e.g., copper) that connects the electronics within the electronics body 156 to the electronics portion of the sensing body 152 (e.g. to electrodes on the sensing region 153).

[0179] This tethered sensor design of these embodiments advantageously allows for an optimal design of the sensing body without concern for the effects of the foreign body response caused by the electronics body. The tether can be design shorter or longer, and stiffer or more flexible, in order to optimize the isolation, strain relief, and/or implantation issues.

[0180] FIG. 11A illustrates a tethered sensor 150a includes a sensing body 152a, a flexible tether 158a, and an electronics body 156a. In this exemplary embodiment, the sensing body 152a is disk-like with a curved surface on which the sensing region 153a is located. An anchoring material 154a encircles the sensing body for anchoring to the tissue. The tether acts as a strain relief, isolating the adverse effects of the FBC that forms around the electronics body 156a from the FBC that forms around the sensing body 152a.

[0181] FIG. 11B illustrates an alternative tethered sensor 150b that includes a sensing body 152b, a flexible tether 158b, and an electronics body 156b. In this exemplary embodiment, the sensing body 152b comprises a cylindrical body with the sensing region 153b on a curved end. The tether 158b is formed from a flexible material and may be formed shorter or longer to adapt to an implantation site. It may be noted that a longer tether may better isolate the adverse effects of the FBC that forms around the electronics body 156b from the FBC that forms around the sensing body 152b, however a shorter tether may simplify the implantation considerations.

[0182] FIG. 11C illustrates an alternative tethered sensor 150c that includes a sensing body 152c, a tether 158c, and an electronics body 156c. In this exemplary embodiment, the tether may be formed from a slightly flexible to somewhat rigid material. A more rigid material may be advantageous in controlling the positioning of the sensing body 152c in vivo, a more flexible material may act as a better strain relief in vivo.

[0183] FIG. 11D illustrates an alternative tethered sensor 150d that includes a plurality of sensing bodies 152d, a tether 158d, and an electronics body 156d. In this exemplary embodiment, the plurality of sensing bodies 152d with sensing regions on a curved portion of the sensing body and anchoring material such as described elsewhere herein, however may provide additional advantages including for example, the ability to remotely turn on/off one or more of the sensing bodies 152c, the ability to determine which sensing body 152d is performing more optimally and/or consistently for optimizing accuracy and implantation site, and the ability to have a “back up” sensing body 152d in the event one or more of the sensing bodies fails to function as required.

[0184] FIGS. 12A to 12B are perspective views of a sensor in an alternative embodiment wherein an electronics body is independent of the sensing bodies in a preassembled state and wherein the sensing bodies are independently inserted (and operatively connected) to the electronics body in a minimally invasive manner. Particularly, FIG. 12A illustrates the sensor wherein all four sensing bodies have been inserted and locked within the ports of the electronics body; FIG. 12B includes a cut-away portion to illustrate how the sensing body locks into electrical contact within a port of the electronics body. In this embodiment, the sensor 160 includes a plurality of independent sensing bodies 162, also referred to as biointerface probes, and include any necessary components (e.g., electrodes, biointerface materials, etc.) to sense an analyte of interest. The sensing bodies 162 further comprise electrical contacts 164 that allow the sensing bodies to operatively connect (and lock) within the multiple (optionally inclined) ports 166 of the electronics body 168. The sensing bodies 162 may be somewhat flexible and configured with a curvature and anchoring material such as described elsewhere herein.

[0185] In practice, the electronics body 168 may be implanted in the subcutaneous tissue without particular concern for the design (e.g., anchoring material, curvature, etc) and its effect on the formation of a FBC. After the FBC has healed around the electronics body 168, the sensing bodies 162 can be individually inserted in a minimally invasive manner (e.g., guide wire introduced with needle and sheath) as needed. Advantageously, each sensing body 162 functions up to about one year or more in vivo. Accordingly, when a sensing body fails to function as needed, another sensing body 162 may be inserted into another port 166 of the electronics body 168.

[0186] It may be noted that the sensors of preferred embodiments may be rigid or flexible, and of any suitable shape, including but not limited to rectangular, cylindrical, square, elliptical, oval, spherical, circular, ellipsoidal, ovoid, hourglass, bullet-shaped, porpoise-nosed, flat sheet, accordion, or any other suitable symmetrical or irregular shape. Corners may range from sharp to slightly round, to substantially round. While the sensors of preferred embodiments are preferably employed to determine the presence of an analyte, devices of preferred geometries may also be constructed for drug delivery, immunoisolation, cell transplantation, and the like. For example, the preferred device configurations can be suitable for use in fabricating an artificial pancreas.

[0187] In addition to a simple circular curvature, the curvature can also be elliptical or parabolic. The curvature can be perfectly symmetrical about the sensor head, or can possess some degree of asymmetry. While a true curvature is generally preferred, in certain embodiments a triangular profile or other polygonal profile with rounded edges may also be

employed. While a smooth surface is generally preferred, in certain embodiments it may be desired to incorporate local features, such as bumps, dimples, ridges, and the like, while maintaining an overall curvature. It is generally preferred that each surface is convex, or less preferably flat but not concave. However, in certain embodiments a slightly concave or recessed surface may be acceptable presuming it is located sufficiently far from the sensing region that any chronic inflammatory response will not translate to the area adjacent the sensor head. The sensor head preferably protrudes above the radius of curvature or is flush with the radius of curvature. A recessed sensor head is generally not preferred. However, in certain embodiments such a configuration may be acceptable.

[0188] The sensor head may be positioned on any convenient location of on the device. Particularly preferred locations are the geometric center of a surface of the device, or offset to one side. In certain embodiments it may be desirable to incorporate multiple sensor heads on a single device. Such sensor heads may be spaced apart so as to maximize the distance between the sensor heads, or grouped together at one location on the device.

#### Manufacture of Sensor Body

[0189] In a preferred embodiment, the sensor is formed by substantially entirely epoxy encapsulating the sensor electronics; that is, the sensor body, outside the sensor head, is comprises an epoxy resin body. During the manufacture of the sensor body of the preferred embodiment, the sensitive electronic parts (e.g. battery, antenna, and circuit board, such as described in copending U.S. patent application Ser. No. 10/633,367 filed on Aug. 1, 2003 and entitled “SYSTEM AND METHODS FOR PROCESSING ANALYTE SENSOR DATA”) are substantially entirely encapsulated in epoxy, with the exception of the sensor head. In some molding processes, the epoxy body may be formed with a curvature on a portion thereof. After the epoxy has completely cured, additional curvature may be machined, milled, laser-etched, or otherwise processed into the epoxy body to form the final geometric shape. In alternative embodiments, a light epoxy coating may be applied to the sensitive electronic parts, after which injection molding or reaction injection molding (RIM) may be used to form the final shape of the epoxy body. While a preferred sensor is constructed of epoxy resin, a non-conductive metal, ceramic or other suitable material may be used.

#### Anchoring Material & Implantation

[0190] In one embodiment, the entire surface of the sensor is covered with an anchoring material to provide for strong attachment to the tissues. In another embodiment, only the sensor head side of the sensor incorporates anchoring material, with the other sides of the sensor lacking fibers or porous anchoring structures and instead presenting a very smooth, non-reactive biomaterial surface to prevent attachment to tissue and to support the formation of a thicker capsule. The anchoring material may be selected from the group consisting of: polyester, polypropylene cloth, polytetrafluoroethylene felts, expanded polytetrafluoroethylene, and porous silicone.

[0191] FIG. 13A is a side view of an analyte sensor with anchoring material on a first and second major surface of the device, including the surface on which the sensing region is located, wherein the analyte sensor is implanted subcutane-

ously and is ingrown with fibrous, vascularized tissue. FIG. 13B is a side view of an analyte sensor with anchoring material on a first major surface on which the sensing region is located, and wherein a second major surface is substantially smooth.

[0192] While these configurations of anchoring materials are particularly preferred, other configurations may also be suitable for use in certain embodiments, including configurations with different degrees of surface coverage. For example, from less than about 5, 10, 15, 20, 25, 30, 35, 40, 45, or 50% to more than about 55, 60, 65, 70, 75, 80, 85, 90, or 95% of the surface of the device may be covered with anchoring material. The anchoring material may cover one side, two sides, three sides, four sides, five sides, or six sides. The anchoring material may cover only a portion of one or more sides, for example, strips, dots, weaves, fibers, meshes, and other configurations or shapes of anchoring material may cover one or more sides. Likewise, while silicone and polyester fibers are particularly preferred, any biocompatible material capable of facilitating anchoring of tissue to the device may be employed.

[0193] It may be noted that the optimum amount of anchoring material that may be used for any particular sensor is dependent upon one or more of the following parameters: implantation site (e.g., location in the host), surface area, shape, size, geometry, mass, density, volume, surface area-to-volume, surface area-to-density, and surface area-to-mass. For example, a device with a greater mass as compared to a device with a lesser mass may require more anchoring material to support the greater mass differential.

[0194] In preferred embodiments, the sensor of the described geometry is implanted at the interface between two kinds of tissue, and is preferably anchored to the more robust tissue type. For example, the sensor may be placed adjacent to an organ (for example, a kidney, the liver, or the peritoneal wall), or adjacent to the fascia below adipose tissue. When implanted in such a fashion, the sensor geometry minimizes force transference, permitting non-anchored tissue to move over the smooth surface of the sensor, thereby minimizing the force transferred to the underlying tissue to which the sensor is anchored. While it is generally preferred to anchor the sensor to the more robust tissue type, in certain embodiments it may be preferred to anchor the sensor to the less robust tissue type, permitting the more robust tissue to move over the smooth surface of the sensor. While the sensor geometries of preferred embodiments are particularly preferred for use at tissue interfaces, such sensors are also suitable for use when implanted into a single type of tissue, for example, muscle tissue or adipose tissue. In such embodiments, however, the sensor geometry may not confer any benefit, or only a minimal benefit, in terms of force transference. Other benefits may be observed, however. In another embodiment, the sensor may be suspended, with or without sutures, in a single tissue type, or be placed between two tissue types, and anchoring material covering substantially the entire surface of the device may be employed.

[0195] In some alternative embodiments, a mechanical anchoring mechanism, such as prongs, spines, barbs, wings, hooks, helical surface topography, gradually changing diameter, or the like, may be used instead of or in combination with anchoring material such as described herein. For example when an oblong or cylindrical type sensor is implanted within the subcutaneous tissue, it may tend to slip along the pocket that was formed during implantation, particularly if some

additional space exists within the pocket. This slippage can lead to increased inflammatory response and/or movement of the sensor prior to or during tissue ingrowth. Accordingly, a mechanical mechanism can aid in immobilizing the sensor in place, particularly prior to formation of a mature foreign body capsule. One example of mechanical anchoring means is shown on FIG. 13B, at 179; however, it should be noted that the placement and configuration of a mechanical anchoring mechanism is broad in scope as described herein.

[0196] FIG. 13A illustrates the surface of the sensor 140 in mechanical contact with the overlying tissue 172, as well as the underlying muscle fascia 174, due to the ingrowth of the fibrous tissue and vasculature. In this embodiment, any surface of the sensor 170 covered with anchoring material 176 is typically ingrown with fibrous, vascularized tissue 178, which aids in anchoring the sensor and mitigating motion artifact. It may be noted however, that in some cases, forces applied laterally to this tissue may be translated to the sensor, and likewise to the fascia side of the sensor, causing potential disruption of the interface with the fascia. Therefore, although the radial profile of the side of the sensor incorporating the sensor head assists in preventing forces in the distal subcutaneous tissue from exerting forces on the sensor head side, which is attached to the muscle fascia by an anchoring material, complete coverage of the device with anchoring material may not be preferred in certain embodiments.

[0197] An anchoring material covering the sensor may also make it difficult to remove the sensor for maintenance, repair, or permanent removal if its function is no longer necessary. It is generally difficult to cut down through the surrounding tissue to the surface of the sensor without also cutting into the anchoring material and leaving some of it behind in the patient's tissues. Leaving a portion of the sensor free of anchoring material enables the sensor to be more easily removed by locating the smooth surface, grasping the sensor with a holding tool, and then cutting along the plane of the anchoring material to fully remove the sensor. In certain embodiments, however, it may be desirable for the entire surface of the sensor, or a substantial portion thereof, to be covered with an anchoring material. For example, when implanted into a single tissue type (subcutaneous adipose tissue, or muscle tissue), it may be desirable to have anchoring over all or substantially the entire surface of the sensor. In still other embodiments, no anchoring at all may be preferred, for example, in sensors having very small dimensions. One contiguous sheet of anchoring material can be employed, or two or more different sheets may be employed, for example, an array of dots, stripes, mesh, or other suitable configuration of anchoring material.

[0198] FIG. 13B illustrates a preferred embodiment wherein the surface 180 of the sensor facing away from the muscle fascia 174 (e.g., surface opposite the sensing region) is not covered with anchoring material, but instead is a smooth, biocompatible material that is non-adhesive to tissues 182. It is also generally preferred that the surface 180 facing away from the fascia have a radius of curvature, although in certain embodiments it may also be acceptable for the surface to have another shape, for example, a flat surface. When mechanical force is applied to the overlying tissue, the force is dissipated in the elastic foreign body response overlying the sensor, and is not effectively translated through the sensor to the biointerface with the fascia. This preferred configuration decreases damage to the biointerface caused by external forces. Moreover, for sensor removal, the surgeon



can easily find the outermost surface of the sensor without cutting into it. The outermost aspect of the sensor is surrounded by a thick foreign body capsule, which substantially frees the sensor when it is cut free. Once the sensor is located and grasped by the surgeon, complete removal by careful dissection of the face of the sensor associated with the fascia can be readily accomplished. Transference of lateral force around a sensor with anchoring material covering the entire surface compared to sensors with anchoring materials covering only the face with the sensor head are depicted in FIG. 13A and FIG. 13B, respectively.

[0199] In other words, in FIG. 13A, vascular and fibrous tissues 178 intertwine with the anchoring material 176. When a force is applied to tissue overlying the sensor of FIG. 13A, it may be translated into the sensor because of the mechanical attachment of the sensor to the fibrous tissue, which grows into the interstices of the anchoring material. In contrast, the sensor of FIG. 13B is smooth on the side opposite the fascia. When mechanical energy is applied to the overlying tissue, it is not effectively transferred to the sensor because the tissue is not attached to the sensor nor intertwined with it.

[0200] It may be noted that the smoothness of the surface of the device can be measured by any suitable method, for example, by profilometry as described in U.S. Pat. No. 6,517,571, the contents of which is hereby incorporated by reference in its entirety. Measurements are preferably taken from representative areas (for example, square areas of 500 microns length on each side) of the smooth surface of the device. A surface is generally considered "smooth" if it has a smoothness of less than 1.80 microns RMS. Surfaces with a smoothness greater than or equal to 1.80 microns RMS are generally considered "rough." In certain embodiments, however, the cut-off between "rough" and "smooth" may be higher or lower than 1.80 microns RMS.

[0201] Profilometry measurements can be performed with a Tencor Profiler Model P-10, measuring samples of square areas of 500-micron length per side. Surface data measurements can be made using the Tencor Profiler Model P-10 with a MicroHead or Exchangeable Measurement Head (stylus tip radius of 2.0 microns with an angle of 60°). Preferred menu recipe settings for the profilometer are as follows:

Scan length:	500 microns
Scan speed:	50 microns/second
Sampling rate:	200 Hz
No. of traces:	50
Spacing between traces:	10 microns
No. of points/trace:	2000
Point interval:	0.25 microns
Stylus force:	5 mg
Range/resolution:	65 microns/0.04 Angstroms
Profile type:	Peaks and valleys
Waviness filter:	45 mm/1.8 in.

[0202] Cursors can be set at each end of the length of each area to be sampled, for example, at 0 microns and at 500 microns. Scans can be performed in the longitudinal direction of tubular samples, or in any convenient direction for samples of other shapes. A parameter correlating to roughness of surfaces of the devices of preferred embodiments is  $R_q$ , which is the Root-Mean-Square (RMS) roughness, defined as the geometric average of the roughness profile from the mean line measured in the sampling length, expressed in units of microns RMS.

[0203] The use of an alternative (finer) waviness filter during profilometry allows for materials that include gross surface non-uniformities, such as corrugated surfaces made from microscopically smooth materials.

[0204] In certain embodiments it is preferred that the smooth surfaces of the device are smooth in their entirety, namely, along the entire length of the surface. For surfaces of relatively uniform smoothness along their entire length, surface measurements are preferably made at three points along the length of the surface, specifically at points beginning at one fourth, one half and three fourths of the length of the surface as measured from one end of device to the other. For surfaces of non-uniform surface character along their entire length, five samples equally spaced along the length are preferably considered. The measurements from these 3-5 sample areas are then averaged to obtain the surface value for the smooth surface. In other embodiments, however, other methods of obtaining measurements may be employed.

[0205] An article entitled "Atomic force microscopy for characterization of the biomaterial interface" describes the use of AFM for consideration of surface smoothness (Siedlecki and Marchant, *Biomaterials* 19 (1998), pp. 441-454). AFM may be usefully employed for the smoothness evaluation of device surfaces where the resolution of profilometry is marginally adequate for extremely smooth surfaces. However, for purposes of the preferred embodiments, profilometry measurements made using the above-described Tencor profilometer are generally adequate for determining the smoothness of the device surface

#### EXAMPLES

[0206] Weekly infusion studies were conducted for four-weeks to investigate the effects of sensor geometries of preferred embodiments on the functional performance of glucose sensors. A first group of sensors ( $n=5$ ) included a cylindrical geometry similar to that described with reference to FIG. 4. A second group of sensors ( $n=6$ ) included a thin, oblong geometry similar to that described with reference to FIG. 5. The functional aspects of each sensor were constructed in a similar manner, such as described in Published Patent Application No. 2003/0032874, which is incorporated herein by reference. The sensors were then implanted into the subcutaneous tissue in dogs between the fascia and adipose tissues, and sensor function evaluated by weekly glucose infusion tests.

[0207] The implantation entailed making a 1-inch incision, then forming a pocket lateral to the incision by blunt dissection. After placement of the device with the sensing region facing towards the fascia, a suture was placed by pulling the connective tissue together at the end of the device proximal to the incision. It is believed that the sutures held effectively during wound healing and device integration with tissues.

[0208] FIG. 14A is a graph showing the percentage of functional sensors from the two different sensor geometry groups. The x-axis represents time in weeks; the y-axis represents percentage of functional sensors for each group during the weekly infusion studies. It is known that an initial startup period exists for sensors implanted in the subcutaneous space, between about one and three weeks, during which delayed sensor functionality may be related to the amount and speed of tissue ingrowth into the biointerface, as described with reference to copending U.S. patent application Ser. No. 10/647,065 filed Aug. 22, 2003 and entitled "POROUS MEMBRANE FOR USE WITH IMPLANTABLE

DEVICES.” Interestingly, both sensor geometries functioned substantially as expected in that the majority of devices were functional by week four. However, the sensors of the thin, oblong sensor geometry group showed faster start-up times as evidenced by a higher percentage of functional sensors at weeks two and three.

[0209] The delayed start-up of the cylindrical group as compared to the thin, oblong group is believed to be due to delayed ingrowth of tissues or lack of ingrowth of tissues, which effects device function through lack of glucose sensitivity, compromised function after start-up, low sensitivity, and long time lags. One cause for this delay of or lack of tissue ingrowth in the cylindrical group is believed to be the placement of the sensing region on the device. Particularly, when a sensor is implanted in the subcutaneous space between two tissue types, such as the adipose subcutaneous tissue and the fascia, optimal tissue ingrowth may occur when the sensor is directly adjacent and fully engaged with the fascia, such as described with reference in FIG. 5B. In contrast to the sensors of the thin, oblong geometry group, when the sensors of the cylindrical are implanted in the pocket formed between the two tissue types, a space may exist adjacent at least a portion of the sensing region between the two tissue types creating delayed or lack of tissue ingrowth due to spacing from soft tissue. Accordingly, it may be advantageous to design the sensing region on a sensor body such that the entire sensing region is directly adjacent to the fascia or similar tissue immediately after implantation.

[0210] Some additional observations may be directly related to the delayed sensor function in the cylindrical sensors of this study. For example, the thin, oblong geometry as compared to the cylindrical geometry does not protrude from the host as much and is less amenable to accidental bumping or movement, and less available for patient “fiddling.” Thus, it may be inferred that overall dimensions may effect sensor geometry such that by increasing the discreteness of the geometry (e.g., mass, shape, dimensions), sensor functionality may improve. As another example, the thin, oblong geometry as compared to the cylindrical geometry is less susceptible to torsion and/or rotational forces, which may create motion artifact and therefore chronic inflammatory response at the device-tissue interface. In other words, with the sensor head oriented down towards the fascia, and nearer to the center of the sensor, downward pressure on either end is not transferred as shear force to the sensor head; even if the sensor is moved, the sensor head more likely remains adjacent to the tissue so that it may heal in a favorable fashion, unlike the sensors wherein the tip is positioned on an end of the sensor body, which can leave a space after lateral movement. From this observation, it may be hypothesized that surface area-to-volume ratio may effect the function of the sensor. Particularly, an increased surface area-to-volume ratio, particularly as a consequence of reducing the volume of the sensor, may decrease the effects of forces (e.g., torsion, rotational, and shearing) caused by behavioral and environment movement. Similarly, optimization of surface area-to-mass and surface area-to-density ratios may impact healing.

[0211] FIG. 14B is a graph showing the average R-value of sensors from a study of the two different sensor geometries implanted in a host. The x-axis represents time in weeks; the y-axis represents average R-value for each group of sensors during each weekly infusion study. R-values were obtained by correlating sensor output to the externally derived meter values, and performing a least squares analysis, such as

described with reference to copending U.S. patent application Ser. No. 10/633,367 filed on Aug. 1, 2003 and entitled “SYSTEM AND METHODS FOR PROCESSING ANALYTE SENSOR DATA.”

[0212] It may be observed that both geometry groups performed with sufficient accuracy by week three (e.g., greater than 0.79 R-value constitutes sufficient accuracy in one example). It may also be observed that the sensors of the thin, oblong group increased in accuracy and were more consistent than the sensors of the cylindrical group. It is believed that the slightly improved performance of the thin, oblong group as compared to the cylindrical group may be due to a variety of factors, including those described with reference to FIG. 11A, and additional factors such as surface area, size, mass, density, volume, surface area-to-volume, surface area-to-density, and surface area-to-mass.

[0213] From the observations of the above described study, optimization of the sensor geometry may additionally include: 1) density optimization to better correspond to the density of tissue (e.g., fascia or adipose), 2) surface area-to-volume optimization by increasing the surface area-to-volume ratio of the sensor, 3) size optimization by decreasing the overall size, mass, and/or volume of the sensor, and 4) surface area-to-mass optimization by increasing the surface area-to-mass ratio of the sensor, for example.

[0214] Table 1 illustrates additional analysis from the above described infusion study, including a comparison of average R-value at week 4 and standard deviation at week 4 for the two groups of sensors.

TABLE 1

Results of Geometry Study	Cylindrical Geometry with sensor on curved end	Thin, oblong geometry with sensor on curved major surface
Average R-value at Week 4	0.73	0.87
Standard Deviation at Week 4	0.41	0.08

[0215] As described above with reference to FIG. 11B, the average R-value at week 4 was better for the thin, oblong group as compared to the cylindrical group. Additionally the average standard deviation of the thin, oblong group as compared to the cylindrical group was much lower, indicating greater consistency and tighter tolerances with the thin, oblong group. As described above with reference to FIGS. 11A and 11B, this performance differential may be due to additional geometric factors such as surface area-to-volume ratio, size, mass, and surface area-to-density ratio, for example.

[0216] The above description discloses several methods and materials of the present invention. This invention is susceptible to modifications in the methods and materials, as well as alterations in the fabrication methods and equipment. Such modifications will become apparent to those skilled in the art from a consideration of this disclosure or practice of the invention disclosed herein. Consequently, it is not intended that this invention be limited to the specific embodiments disclosed herein, but that it cover all modifications and alternatives coming within the true scope and spirit of the invention as embodied in the attached claims. All patents, applications, and other references cited herein are hereby incorporated by reference in their entirety.

What is claimed is:

**1.** An implantable sensor for use in measuring a concentration of an analyte in a bodily fluid, the sensor comprising: a substantially cylindrical body comprising a sensing region and adapted for transport of at least one analyte from a bodily fluid to the sensing region, wherein the substantially cylindrical body is defined by a curved lateral surface and two ends, and wherein the sensing region is located on the curved lateral surface such that when a foreign body capsule forms around the sensor in vivo, a contractile force is exerted by the foreign body capsule toward the sensing region.

**2.** The sensor of claim **1**, wherein the substantially cylindrical body comprises a thermoplastic plastic or a thermoset plastic.

**3.** The sensor of claim **2**, wherein the substantially cylindrical body comprises epoxy.

**4.** The sensor of claim **1**, further comprising a battery and a circuit board housed within the substantially cylindrical body.

**5.** The sensor of claim **1**, further comprising an application specific integrated circuit housed within the substantially cylindrical body.

**6.** The sensor of claim **1**, wherein the sensing region comprises a plurality of sensors.

**7.** The sensor of claim **6**, wherein the plurality of sensors are configured to sense a same analyte.

**8.** The sensor of claim **6**, wherein the plurality of sensors are configured to sense at least two different analytes.

**9.** The sensor of claim **1**, wherein the sensing region is configured for measurement of a concentration of glucose in the bodily fluid.

**10.** The sensor of claim **1**, wherein the sensing region comprises an electrode.

**11.** The sensor of claim **1**, wherein the sensor is configured for implantation in a soft tissue of a body.

**12.** The sensor of claim **1**, further comprising a porous biointerface material that covers at least a portion of the sensing region.

**13.** The sensor of claim **12**, wherein the biointerface material comprises interconnected cavities dimensioned and arranged to create contractile forces that counteract a generally uniform downward fibrous tissue contracture caused by the foreign body capsule in vivo so as to interfere with formation of occlusive cells.

**14.** The sensor of claim **1**, wherein the sensing region encircles the curved lateral surface.

\* \* \* \* \*