



US 20040216236A1

(19) **United States**

(12) **Patent Application Publication**  
**Lievestro et al.**

(10) **Pub. No.: US 2004/0216236 A1**

(43) **Pub. Date: Nov. 4, 2004**

(54) **SEAT CUSHION, AND SEAT APPARATUS PROVIDED WITH SUCH A SEAT CUSHION**

**Publication Classification**

(76) Inventors: **Robert Lievestro**, Elst (NL); **John Willem Herman Heijs**, Lissersbroek (NL)

(51) **Int. Cl.<sup>7</sup>** ..... **A47C 20/02**

(52) **U.S. Cl.** ..... **5/655.9; 5/652**

(57) **ABSTRACT**

Correspondence Address:

**WEINGARTEN, SCHURGIN, GAGNEBIN & LEBOVICI LLP**  
**TEN POST OFFICE SQUARE**  
**BOSTON, MA 02109 (US)**

A seat cushion, in particular for an aircraft seat, provided with:

a first foam body (2);

a second foam body (3) extending below the first foam body (2);

detachable connecting means (7, 8) to connect the first foam body (2) to the second foam body (3);

wherein the first foam body is provided with a covering (5) which is fixedly connected to this first foam body (2).

(21) Appl. No.: **10/776,018**

(22) Filed: **Feb. 10, 2004**

(30) **Foreign Application Priority Data**

Feb. 10, 2003 (NL)..... 1022632

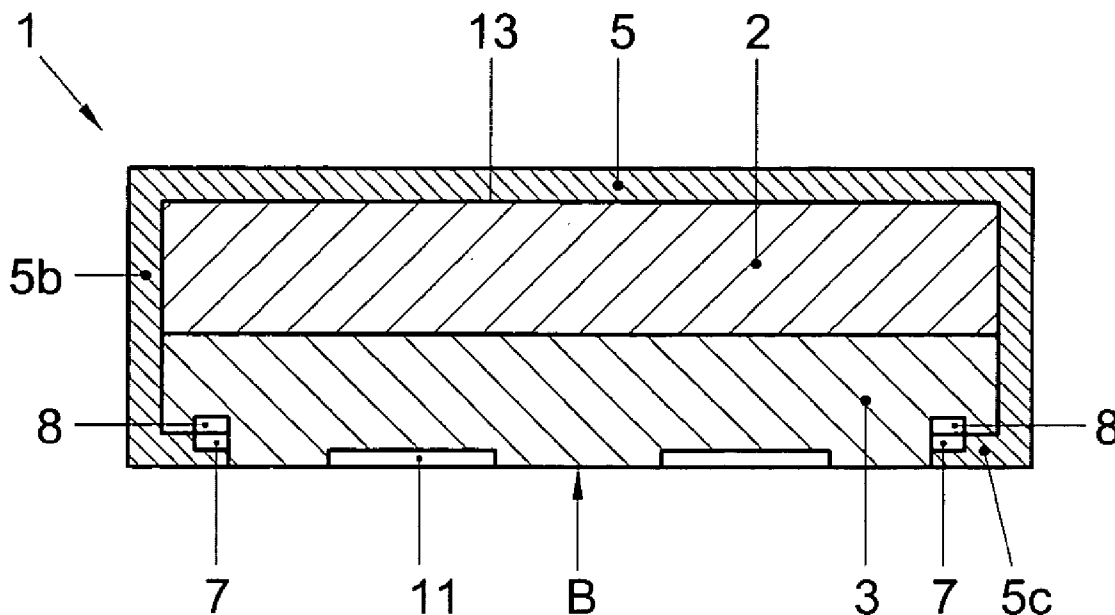

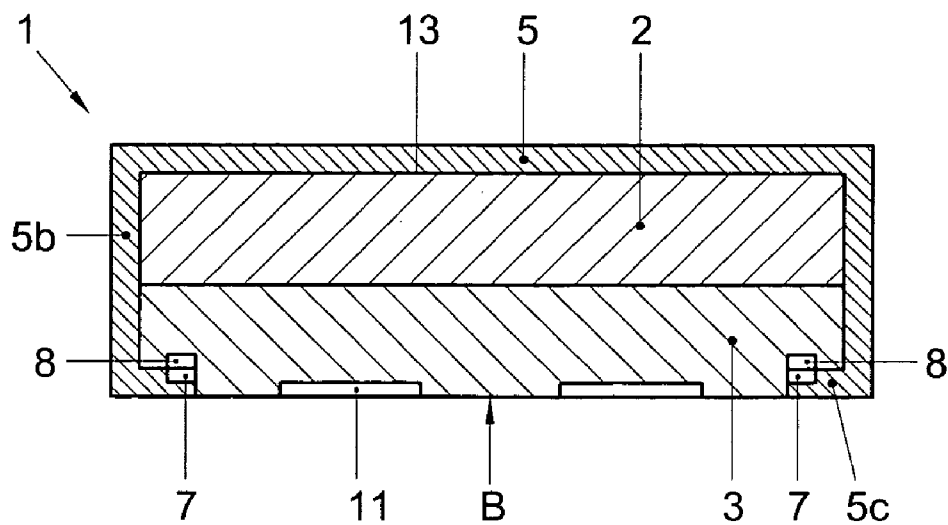

Fig. 1

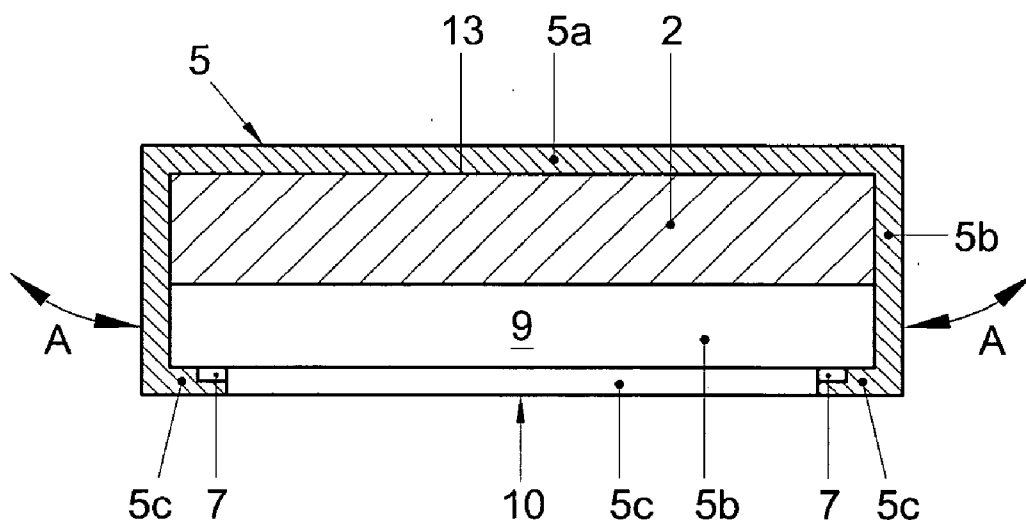

Fig. 2

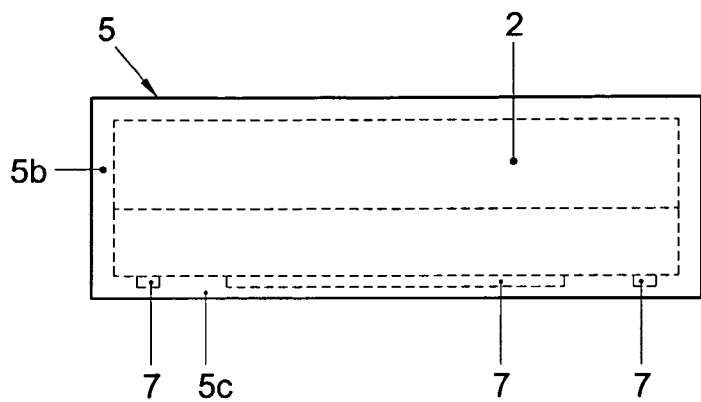

Fig. 3



Fig. 4

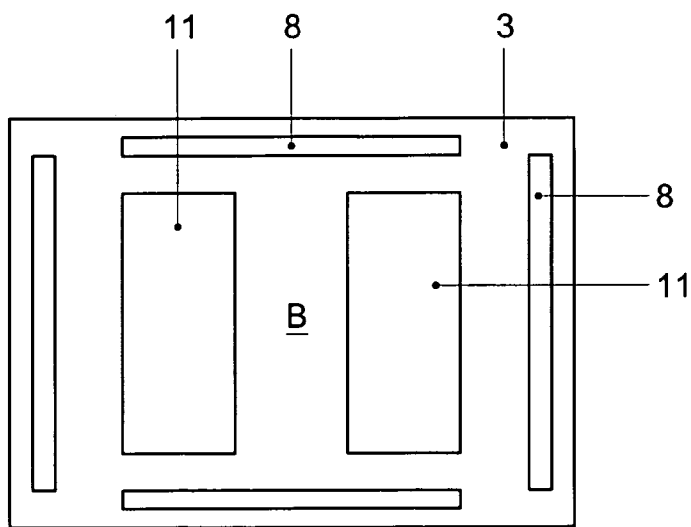

Fig. 5

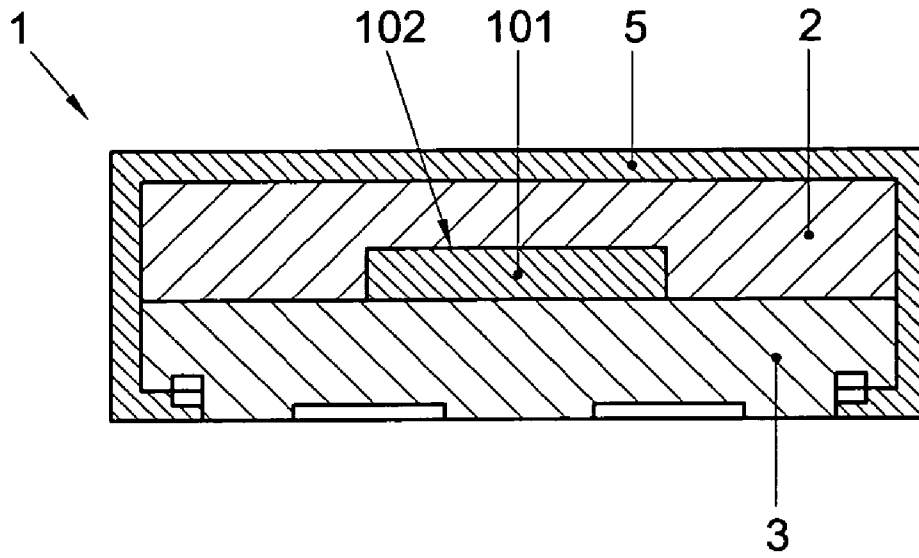

Fig. 6

### SEAT CUSHION, AND SEAT APPARATUS PROVIDED WITH SUCH A SEAT CUSHION

[0001] The invention relates to a seat cushion, in particular for an aircraft seat.

[0002] U.S. Pat. No. 5,632,053 describes an aircraft seat, provided with a seat cushion with two foam bodies provided on top of each other which are detachably connected to each other. The seat cushion is further provided with a covering which is detachably connectable to the lower of the foam bodies. An advantage of this seat cushion is that its upper part, which relatively rapidly wears and soils under the influence of use, can be removed from another part of the seat cushion and from the seat for the purpose of replacement, recycling and/or a separate cleaning.

[0003] A disadvantage of this seat cushion is that the covering is found to crease or wrinkle easily during use. Thus, this seat is relatively uncomfortable and relatively little durable. In addition, the replacement of the upper foam body costs relatively much time, since, for this purpose, each time, the covering needs to be detached before this foam body can be removed.

[0004] The invention contemplates obviating these drawbacks. In particular, the invention contemplates a seat cushion which is comfortable and durable.

[0005] For this purpose, the seat cushion according to the invention is characterized by the measures of claim 1.

[0006] In the seat cushion according to the invention, creasing is avoided in a surprisingly simple manner in that the covering is fixedly connected to the first foam body. In addition, the advantage is preserved that the upper part of the seat cushion can easily be separated from another part. In this case, for this purpose, the covering and the first foam body are, moreover, easily detached from the second foam body together. Replacing the upper seat cushion part by a new upper part can thus be done relatively rapidly, which is particularly advantageous when a large number of seat cushions is to be replaced and/or cleaned. It was found that, in this manner, replacement can be carried out considerably more rapidly than with the seat cushion known from U.S. Pat. No. 5,632,053.

[0007] According to a preferred embodiment, at least a part of the seat cushion comprises a lightweight, fire-retardant foam material. This allows the seat cushion to have a lightweight design, which is advantageous for, for instance, use in aircraft.

[0008] Further elaborations of the invention are described in the subclaims. The invention will now be clarified on the basis of two exemplary embodiments and with reference to the drawing, in which:

[0009] FIG. 1 shows a cross-sectional view of an exemplary embodiment of the invention;

[0010] FIG. 2 shows a similar view to FIG. 1, in which the lower cushion part is not shown;

[0011] FIG. 3 shows a side elevational view of the upper cushion part of the exemplary embodiment shown in FIG. 1;

[0012] FIG. 4 shows a side elevational view of the lower cushion part of the exemplary embodiment shown in FIG. 1;

[0013] FIG. 5 shows a bottom view of the side elevational view shown in FIG. 2; and

[0014] FIG. 6 shows a second exemplary embodiment of the invention.

[0015] The first exemplary embodiment shown diagrammatically in FIGS. 1-5 of a seat cushion 1 comprises an upper cushion part 2, 5 and a lower cushion part 3. The upper cushion part comprises an upper foam body 2 and a cover 5. The lower cushion part comprises a lower foam body 3. In the assembled condition shown in FIG. 1 of the exemplary embodiment, the lower foam body 3 extends below the upper foam body 2. As FIG. 1 clearly shows, the foam bodies 2, 3 are formed such that the sides of the foam bodies facing each other substantially completely contact each other. The lower foam body 3 extends below the upper foam body 2 such that a bottom side of the upper foam body 2 is substantially completely supported by the lower foam body 3. Thus, there is no cavity between the sides facing each other of the various foam bodies 2, 3. The seat cushion 1 is thus, in the condition assembled from the foam bodies 2, 3, substantially completely filled with foam material.

[0016] As FIG. 2 shows, an upper part 5a of the covering 5 extends over a top side of the upper foam body 2. The upper covering part 5a is integrally connected to the upper foam body, for instance by a glue connection or the like. Preferably, the upper covering part 5a and the top side of the upper foam body 2 are connected to each other along substantially the whole contact surface 13. The covering 6 is also provided with side flaps 5b extending from this covering top side 5a to lower covering strips or flaps 5c. The covering side flaps 5b, the covering strips 5c and a bottom side of the upper foam body 2 bound an inner space 9 in which the second foam body 3 is receivable. Via an opening 10 provided between the lower covering strips 5c, this space 9 is accessible for providing and removing the lower foam body 3. Preferably, at least the side flaps 5b and lower strips 5c of the covering are manufactured from such material, for instance provided with a slightly flexible material, that these covering parts 5b, 5c can be pulled apart, in particular can be folded or rolled up, to facilitate the access to the inner space 9. In FIG. 2, such a movement of the covering is shown by arrows A.

[0017] The lower strips 5c of the covering 5 are provided with detachable connecting means 7, for instance Velcro or the like, to detachably connect the upper cushion part 2, 5 to respective first connecting means 8 of the lower foam body 3. As FIG. 5 shows, at the bottom side B, near the bottom edges, the lower foam body 3 is provided with any number of strips, in this specific case four strips, of such connecting means 8. At the bottom side B, the lower foam body 3 is further provided with second detachable connecting means 11 to detachably couple the cushion 1 to a seat apparatus, for instance a chair or a couch. Naturally, the cushion 1 can also be placed loosely on a seat apparatus during use, such second connecting means 11 being redundant.

[0018] Preferably, the covering 5 is provided with a fire-retardant material, so that the cushion cannot easily catch fire. The covering 5 may further comprise strengthening material, for instance glass fiber, laminate or the like.

[0019] During use, the cushion can simply be placed on a chair, couch or the like, so that a user can then be comfort-

ably supported by the cushion 1. Because the covering 5 is integrally connected to the top side of the upper foam body 2, the chance of undesired wrinkling and/or creasing in the upper part 5a of the covering 5 is considerably reduced. In addition, this prevents wear of the upper cushion part. Thus, the comfort of the cushion 1 according to the invention is considerably higher compared to cushions known from practice, whose covering is completely loose with respect to the upper foam body.

[0020] When the upper cushion part 2, 5 is to be replaced, the covering 5 is simply detached from the lower foam body 3. Here, side flaps 5b may, for instance, be swung outwards in direction A. Covering 5 and the upper foam body 2 can then be removed from the lower cushion part 3 in one go. In addition, the lower cushion part 3 can easily maintain its position, for instance on the seat apparatus, while a new, clean upper cushion part can rapidly be provided on this lower cushion part 3. Because the covering 5 is connected to the lower foam body 3 near the bottom edges 12 of this body 3, this connection can easily be reached from the outside to be detached and attached.

[0021] Although this is not shown in the drawing, it is further advantageous if the second, at least the lower foam body 3 is also provided with a covering. This covering then preferably extends at least along the bottom side B of this foam body 3. Preferably, this covering of the second foam body is also provided with fire-retardant material and/or glass fiber. The detachable connections 8, 11 of the second foam body 3 may, for instance, easily be provided on the outside of this covering.

[0022] The second exemplary embodiment shown in FIG. 6 differs from the above-described first exemplary embodiment in that the seat cushion 1 is provided with a lightweight, fire-retardant foam material 101. As FIG. 6 shows, in particular, the seat cushion 1 comprises a third, lightweight foam body 101 of fire-retardant material, which third foam body 101 is received in a cavity 102 between the first and second foam body 2, 3, such that this cavity 102 is completely filled by the third foam body 101. As FIG. 6 clearly shows, the lower foam body 3 extends below the upper foam body 2 and the third foam body 101 such that the joint bottom side of the upper foam is body 2 and the third foam body 101 is substantially completely supported by the lower foam body 3. The foam bodies 2, 3, 101 are formed such that the various sides facing each other of the foam bodies substantially completely contact each other. Thus, in the condition assembled from the foam bodies 2, 3, 101, the present seat cushion 1 is substantially filled with foam material, just like in the first exemplary embodiment (see FIG. 1). In the second exemplary embodiment, the cavity 102 is provided in the first foam body 2. However, such a cavity 102 may also extend in other places in the seat cushion 1, for instance also or only in the second foam body 3.

[0023] The lightweight foam body 101 preferably has a lower average density than the first foam body 2 and the second foam body 3. As a result, the seat cushion 1 shown in FIG. 6 has a lower mass than the first exemplary embodiment shown in FIG. 1, which makes the second exemplary embodiment more suitable for use in, for instance, aircraft. The fire-retardant foam material of the third foam body 101 has, in particular, an average density

lower than approximately 0.1 gram/cm<sup>3</sup>, more in particular lower than approximately 0.02 gram/cm<sup>3</sup>. In addition, it is advantageous to use melamine foam as fire-retardant foam material. Melamine foam, which is generally known and available and is, for instance, available from BASF under the name of Basotect®, has good fire-resistant properties and can have a particularly light design.

[0024] The exemplary embodiment shown in FIG. 6 can relatively simply be assembled and mounted. The third foam part 101 can easily be placed in the cavity 102 intended for this purpose when the first and second foam body 2, 3 have been brought in a position moved away from each other, after which the first and second foam body 2, 3 are coupled to each other and receive the fire retardant foam part 101 between them. Here, the third, lightweight foam body 101 may, for instance, be received loosely or fixedly in the cavity 102 between the first and second foam body 2, 3.

[0025] Needless to say, the invention is not limited to the exemplary embodiments described. Various modifications are possible within the scope of the invention as set forth in the following claims.

[0026] For instance, the seat cushion or cushion 1 may be designed in various forms. For instance, the first seat cushion part and/or the second seat cushion part may be provided with straight, inclined and/or bent surfaces.

[0027] Further, the covering 5 may be built up from one or more covering layers and/or contain various materials. This cover 5 may, for instance, also comprise a foam layer.

[0028] In addition, each of the detachable connecting means may be designed in various manners and comprise, for instance, click, button, hook, Velcro, elastic connections and/or the like.

[0029] In addition, the seat cushion may, for instance, be used in various types of seat apparatuses, for instance chairs, couches and/or armchairs, and for, for instance, seat apparatuses in aircraft, vessels and/or vehicles, in particular trains, automobiles and the like.

[0030] Further, the first foam body 2, second foam body 3 and/or the covering 5 may in themselves contain lightweight, preferably fire-retardant foam material. Such fire-retardant foam material may, for instance, comprise a synthetic foam, provided with one or more fire-retardant substances, melamine foam or the like.

1. A seat cushion, in particular for an aircraft seat, provided with:

a first foam body;

a second foam body extending below the first foam body;

detachable connecting means to connect the first foam body to the second foam body;

wherein the first foam body is provided with a covering which is fixedly connected to this first foam body.

2. A seat cushion according to claim 1, wherein the covering is connected to at least an upper surface of the first foam body.

3. A seat cushion according to claim 1, wherein the covering is glued to the first foam body.

4. A seat cushion according to claim 1, wherein the first and second foam body are detachably connected to each other by Velcro connections.

5. A seat cushion according to claim 1, wherein the covering comprises a fire-retardant material.

6. A seat cushion according to claim 1, wherein the said covering comprises glass fiber.

7. A seat cushion according to claim 1, wherein the second foam body is also provided with a covering, wherein the covering of the second foam body preferably comprises a fire-retardant material, wherein the covering of the second foam body preferably comprises glass fiber.

8. A seat cushion according to claim 1, wherein the seat cushion is arranged to be detachably placed on a seat apparatus, in particular a seat and/or couch.

9. A seat cushion according to claim 1, wherein the covering is provided with at least a part of the said detachable connecting means.

10. A seat cushion according to claim 9, wherein the first and second foam body are detachably connectable to each other only via the covering.

11. A seat cushion according to claim 9, wherein the second foam body is arranged, near respective bottom edges, to be detachably connected to the covering.

12. A seat cushion according to claim 1, wherein the covering is provided with an upper covering part, a lower covering part extending opposite it, and side flaps extending between the upper and lower covering part.

13. A seat cushion according to claim 1, wherein the covering and the upper foam body bound an inner space in which the second foam body is receivable.

14. A seat cushion according to claim 13, wherein the lower covering part is provided with an opening offering access to the said inner space.

15. A seat cushion according to claim 1, wherein at least a part of the seat cushion comprises relatively lightweight, fire-retardant foam material.

16. A seat cushion according to claim 15, wherein said fire-retardant foam material has an average density which is lower than approximately 0.1 gram/cm<sup>3</sup>, more in particular lower than approximately 0.02 gram/cm<sup>3</sup>.

17. A seat cushion according to claim 15, wherein said fire-retardant foam material comprises melamine foam.

18. A seat cushion according to claims 15, wherein the said fire-retardant foam material is received in a cavity between said first and second foam body.

19. A seat apparatus, in particular a chair and/or couch, more in particular an aircraft seat, provided with a seat cushion according to claim 1.

20. A vehicle, vessel and/or aircraft, provided with a seat apparatus according to claim 19.

21. A seat cushion according to claim 2, wherein:

the covering is glued to the first foam body;

the first and second foam body are detachably connected to each other by Velcro connections;

the covering comprises a fire-retardant material;

the said covering comprises glass fiber;

the second foam body is also provided with a covering, wherein the covering of the second foam body preferably comprises a fire-retardant material, wherein the covering of the second foam body preferably comprises glass fiber;

the seat cushion is arranged to be detachably placed on a seat apparatus, in particular a seat and/or couch;

the covering is provided with at least a part of the said detachable connecting means;

the first and second foam body are detachably connectable to each other only via the covering;

the second foam body is arranged, near respective bottom edges, to be detachably connected to the covering;

the covering is provided with an upper covering part, a lower covering part extending opposite it, and side flaps extending between the upper and lower covering part;

the covering and the upper foam body bound an inner space in which the second foam body is receivable;

the lower covering part is provided with an opening offering access to the said inner space;

at least a part of the seat cushion comprises relatively lightweight, fire-retardant foam material;

said fire-retardant foam material has an average density which is lower than approximately 0.1 gram/cm<sup>3</sup>, more in particular lower than approximately 0.02 gram/cm<sup>3</sup>;

said fire-retardant foam material comprises melamine foam;

the said fire-retardant foam material is received in a cavity between said first and second foam body.

22. A seat apparatus, in particular a chair and/or couch, more in particular an aircraft seat, provided with a seat cushion according to claim 21.

23. A vehicle, vessel and/or aircraft, provided with a seat apparatus according to claim 22.

\* \* \* \* \*