

(No Model.)

J. L. BROWN.  
TRIPOD.

No. 464,471.

Patented Dec. 1, 1891.

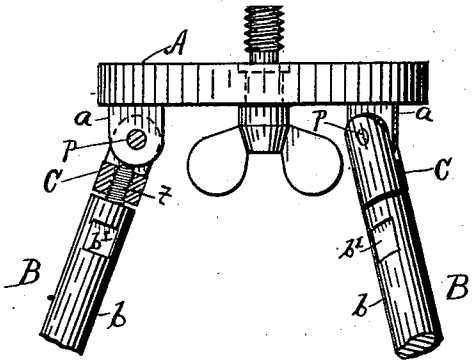

Fig. 1

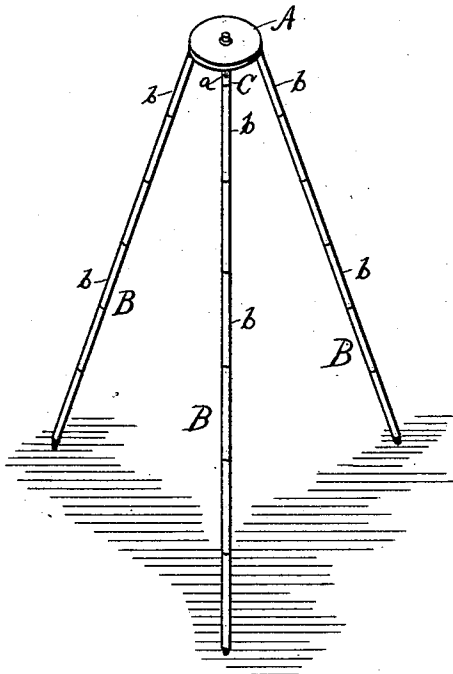

Fig. 2

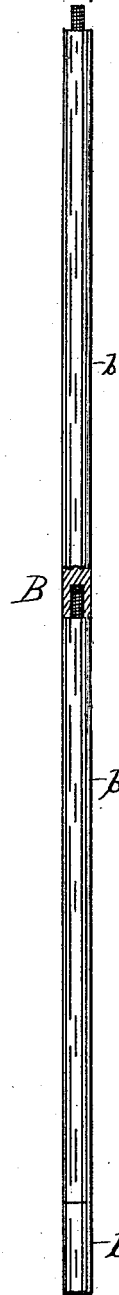

Fig. 3

Witnesses

*Cora Thomas*  
*Hellie Wood*

Inventor

*Julius L. Brown.*

by *a. a. Woodson*  
Attorneys.

# UNITED STATES PATENT OFFICE.

JULIUS L. BROWN, OF ATLANTA, GEORGIA.

## TRIPOD.

SPECIFICATION forming part of Letters Patent No. 464,471, dated December 1, 1891.

Application filed May 7, 1891. Serial No. 391,982. (No model.)

*To all whom it may concern:*

Be it known that I, JULIUS L. BROWN, of Atlanta, in the county of Fulton and State of Georgia, have invented certain new and useful Improvements in Tripods; and I do hereby declare the following to be a full, clear, and exact description of the invention, such as will enable others skilled in the art to which it appertains to make and use the same, reference being had to the accompanying drawings, and to letters of reference marked thereon, which form a part of this specification.

The object of this invention is to improve the construction of tripods to make them more convenient for transportation and for adjustment and more rigid when in use.

The invention consists of several of the features of the device, that will be hereinafter described, and that are shown in the accompanying drawings, in which—

Figure 1 is a side elevation showing the connection of the legs with the disk that forms the support for the theodolite or camera and the means by which the hinges of legs are made rigid. Fig. 2 shows a perspective view of the device. Fig. 3 shows the construction of the legs.

In the several figures the different parts of the device are uniformly marked by reference characters.

On the under side of the disk A are the downwardly-projecting lugs *a*, preferably three in number. The legs B are hinged to the lugs *a* by the pins *p* passing through the forked ends of the hinge-pieces C and said lugs, which forms a hinge-joint. The bottoms of the lugs *a* are semicircular, the axes being the pivoting-pins *p*. The legs B are composed of sections *b*, one end of each section being provided with a threaded hole and the other with a threaded pin, as shown in Fig. 3. These sections *b* may be made of a uniform or of a varying diameter, and if of a varying diameter each section, commencing at the top, may be of a uniformly smaller

diameter of a tapering form, and the larger or top end of each should be of the same size as the smaller or bottom end of the one that it follows. These legs may be made hollow or solid or of any available material according to the requirements.

The hinge-pieces C have tapped holes through them, as shown in Fig. 1, that are in line with the lugs *a* and lugs *t* of the top sections *b* of the legs which screw into said holes, the screws on the legs being long enough to abut against the circular faces of the lugs *a*, thus preventing the movement of the legs, and it is preferable that all of the screws on the several sections should be of uniform length and size.

The legs on being detached from the hinge-pieces may be subdivided into short sections for convenient transportation, and when in use the tripod may be adjusted as to height by using more or less of the section *b*, as required. The height and position being adjusted, the whole structure may be made rigid by the screwing of the top sections against the lugs *a*. Flat faces *b'* for a wrench should be on the top pieces and may be on all.

Having thus described my invention, what I claim as new, and desire to secure by Letters Patent of the United States, is—

In a device of the class specified, the center plate A, having lugs *a* and the swivel C pivoted thereon, having a screw-threaded hole radially therein, and a leg B, having a screw-threaded portion adapted to be screwed into and through said radial hole in said swivel and be forced against the circular portion of said lug, substantially as and for the purpose specified.

In testimony whereof I hereunto affix my signature in presence of two witnesses.

JULIUS L. BROWN.

Witnesses:

A. P. WOOD,  
EDWARD P. WOOD.