



US008960459B2

(12) **United States Patent**  
**Givens**

(10) **Patent No.:** **US 8,960,459 B2**  
(45) **Date of Patent:** **Feb. 24, 2015**

(54) **SLANT-TRUSS CRANE RAIL**

945,751 A \* 1/1910 Butler et al. .... 104/95  
1,204,470 A \* 11/1916 Miller ..... 254/342  
1,296,755 A \* 3/1919 Buckley ..... 105/163.1

(76) Inventor: **Ray Givens**, London (CA)

(Continued)

(\* ) Notice: Subject to any disclaimer, the term of this patent is extended or adjusted under 35 U.S.C. 154(b) by 842 days.

**OTHER PUBLICATIONS**

Unified Industries, Diagram, Undated.

(Continued)

(21) Appl. No.: **13/012,669**

(22) Filed: **Jan. 24, 2011**

*Primary Examiner* — Emmanuel M Marcelo

*Assistant Examiner* — Michael Gallion

(65) **Prior Publication Data**

US 2011/0180507 A1 Jul. 28, 2011

(74) *Attorney, Agent, or Firm* — Katten Muchin Rosenman LLP

**Related U.S. Application Data**

(60) Provisional application No. 61/297,476, filed on Jan. 22, 2010.

(51) **Int. Cl.**

**B66C 19/00** (2006.01)  
**B66C 7/02** (2006.01)  
**B66C 5/02** (2006.01)  
**B66C 5/10** (2006.01)  
**B66C 7/04** (2006.01)

(52) **U.S. Cl.**

CPC ... **B66C 7/02** (2013.01); **B66C 5/02** (2013.01);  
**B66C 5/10** (2013.01); **B66C 7/04** (2013.01)  
USPC ..... **212/73**; 212/74; 212/328; 52/653.2

(58) **Field of Classification Search**

CPC ..... B66C 5/02; B66C 6/00; B66C 17/00;  
E04B 1/24; E04B 2001/2451  
USPC ..... 212/72-74, 122, 328, 336; 52/653.2  
See application file for complete search history.

(56) **References Cited**

**U.S. PATENT DOCUMENTS**

278,774 A \* 6/1883 Capen ..... 212/312  
779,493 A \* 1/1905 MoMyler ..... 414/21

(57) **ABSTRACT**

In one aspect, the invention is directed to an overhead crane with one or more bridge rails, that incorporates a reinforcement truss into its one or more bridge rails so as to reduce the overall mass of the one or more bridge rails. This facilitates movement of a load carried by the bridge by an operator to a destination point, particularly in embodiments wherein the one or more bridge rails do not have any bridge drive motors thereon. Reducing the mass of the bridge can increase the amount of lifted load that can comfortably be maneuvered by an operator, particularly when the bridge is manually moved along the runway. Additionally, reducing the mass of the bridge reduces the momentum associated with the bridge, which can increase the amount of control that the operator has when it is desired to stop the bridge when the load has been maneuvered to its desired destination point. The second reinforcement members may have first and second ends that are inserted into receiving apertures in the first reinforcement member and in a bracket that mounts to the bridge rail respectively. In embodiments wherein the bridge includes two rails and is capable of supporting a load in such a way as to generate a downward force that is offset from the bridge axis, the second reinforcement members may be connected to the first reinforcement member and to brackets in such a way as to prevent the withdrawal of the second reinforcement members from the receiving apertures.

**16 Claims, 14 Drawing Sheets**

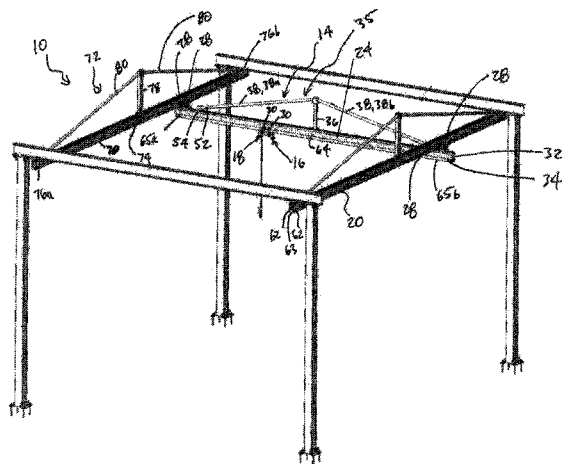

(56)

References Cited

U.S. PATENT DOCUMENTS

1,515,023 A \* 11/1924 Fitch ..... 104/126  
 1,858,183 A \* 5/1932 Bridges ..... 294/63.1  
 3,062,340 A \* 11/1962 Hunnebeck ..... 52/646  
 4,202,529 A \* 5/1980 Fitting ..... 254/89 H  
 4,502,527 A \* 3/1985 Brewer ..... 164/418  
 4,569,453 A \* 2/1986 Oustad ..... 212/299  
 4,730,743 A \* 3/1988 Rosman ..... 212/312  
 4,924,164 A \* 5/1990 Riley ..... 318/587  
 5,022,542 A \* 6/1991 Beier ..... 212/325  
 5,230,197 A \* 7/1993 Hart ..... 52/653.2  
 5,337,908 A \* 8/1994 Beck, Jr. .... 212/312  
 5,385,249 A \* 1/1995 Long, Jr. .... 212/324  
 5,443,151 A \* 8/1995 Taylor ..... 198/860.1

5,526,614 A \* 6/1996 Huang ..... 52/13  
 5,669,518 A \* 9/1997 Kundel ..... 212/315  
 5,694,857 A 12/1997 Taylor  
 5,921,415 A \* 7/1999 Markelz ..... 212/294  
 6,739,096 B2 \* 5/2004 Feldpausch et al. .... 52/36.1  
 7,048,491 B2 \* 5/2006 Windbergs ..... 414/542  
 7,850,026 B2 \* 12/2010 McKay ..... 212/315  
 8,678,209 B2 \* 3/2014 Chernyak ..... 212/324  
 2002/0084238 A1 \* 7/2002 Zingerman ..... 212/179  
 2004/0238473 A1 \* 12/2004 McKay ..... 212/315  
 2012/0005980 A1 \* 1/2012 Kundel et al. .... 52/651.05  
 2013/0112645 A1 \* 5/2013 Laliberte et al. .... 212/312

OTHER PUBLICATIONS

Gorbel Inc., Photograph, Undated.

\* cited by examiner

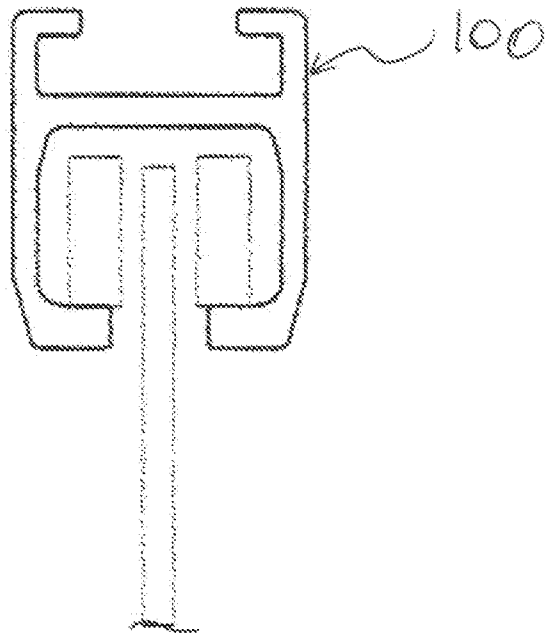

FIG 1  
(PRIOR ART)

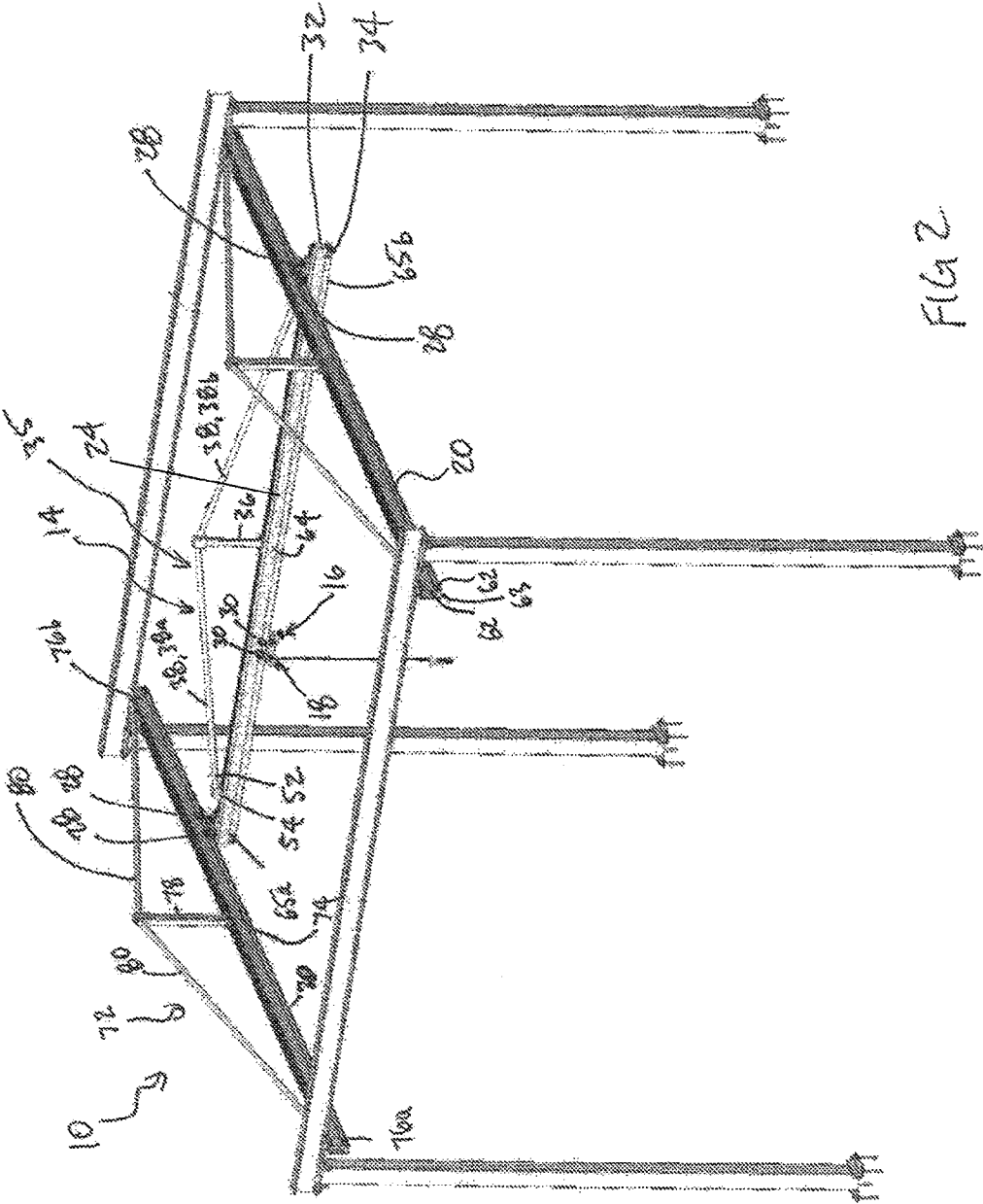

FIG 2

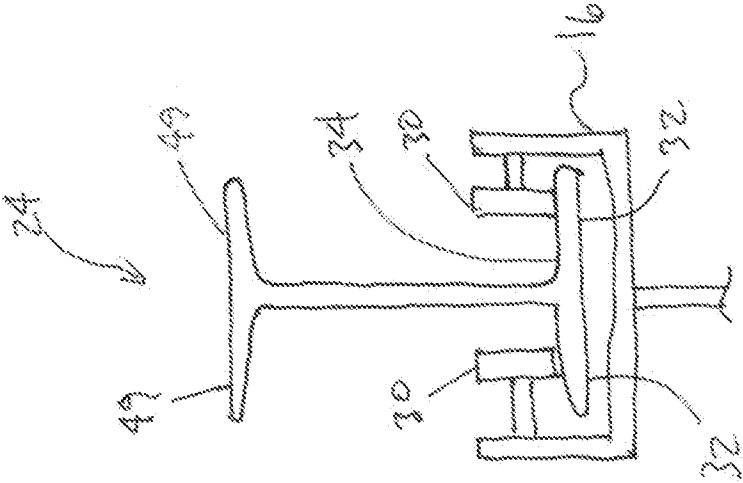

FIG. 3

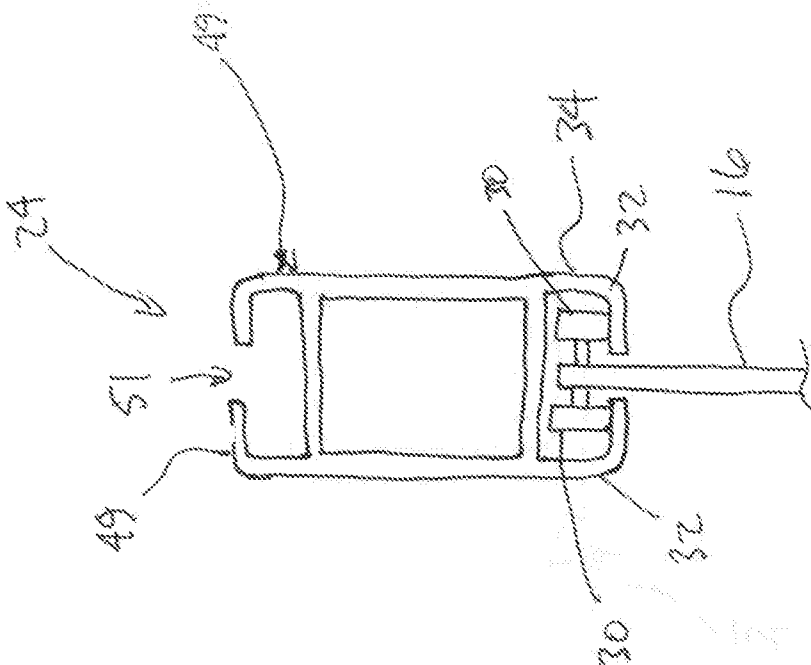

FIG. 4

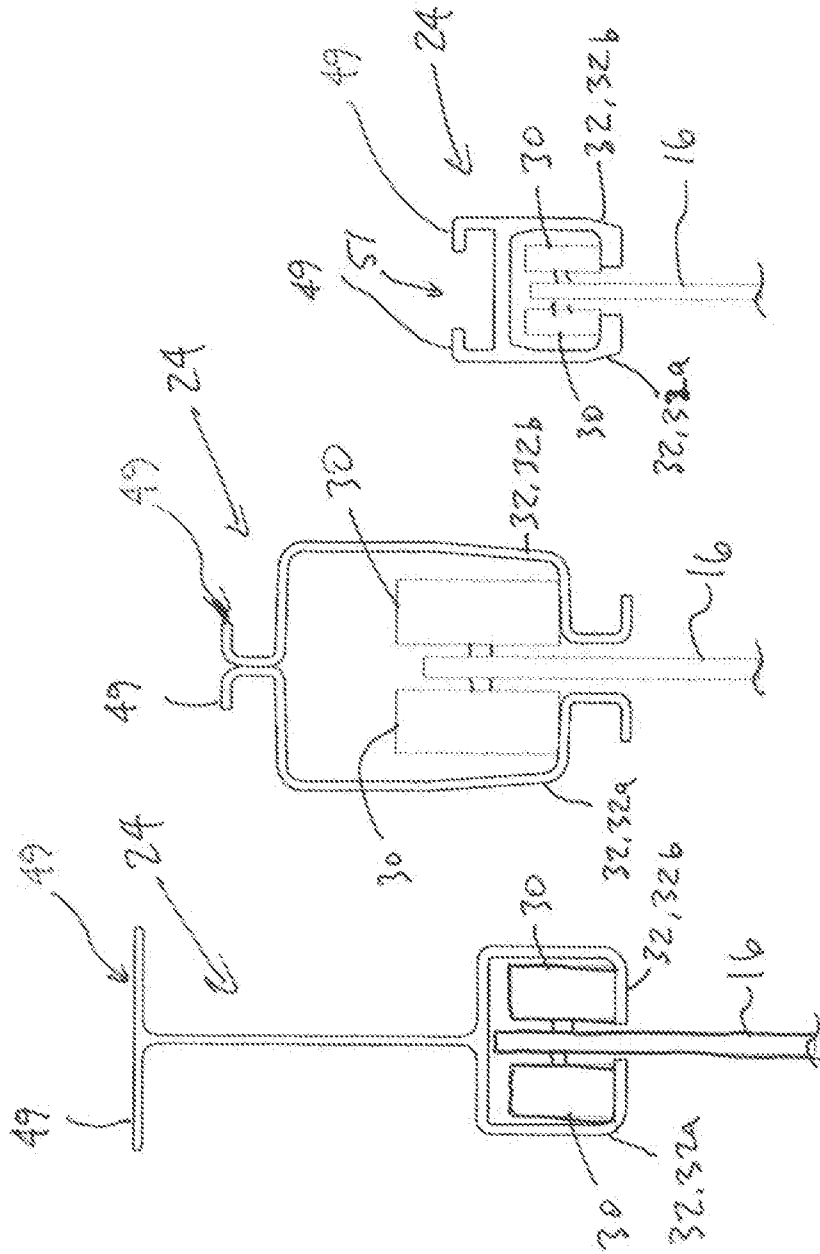

FIG. 7

FIG. 6

FIG. 5

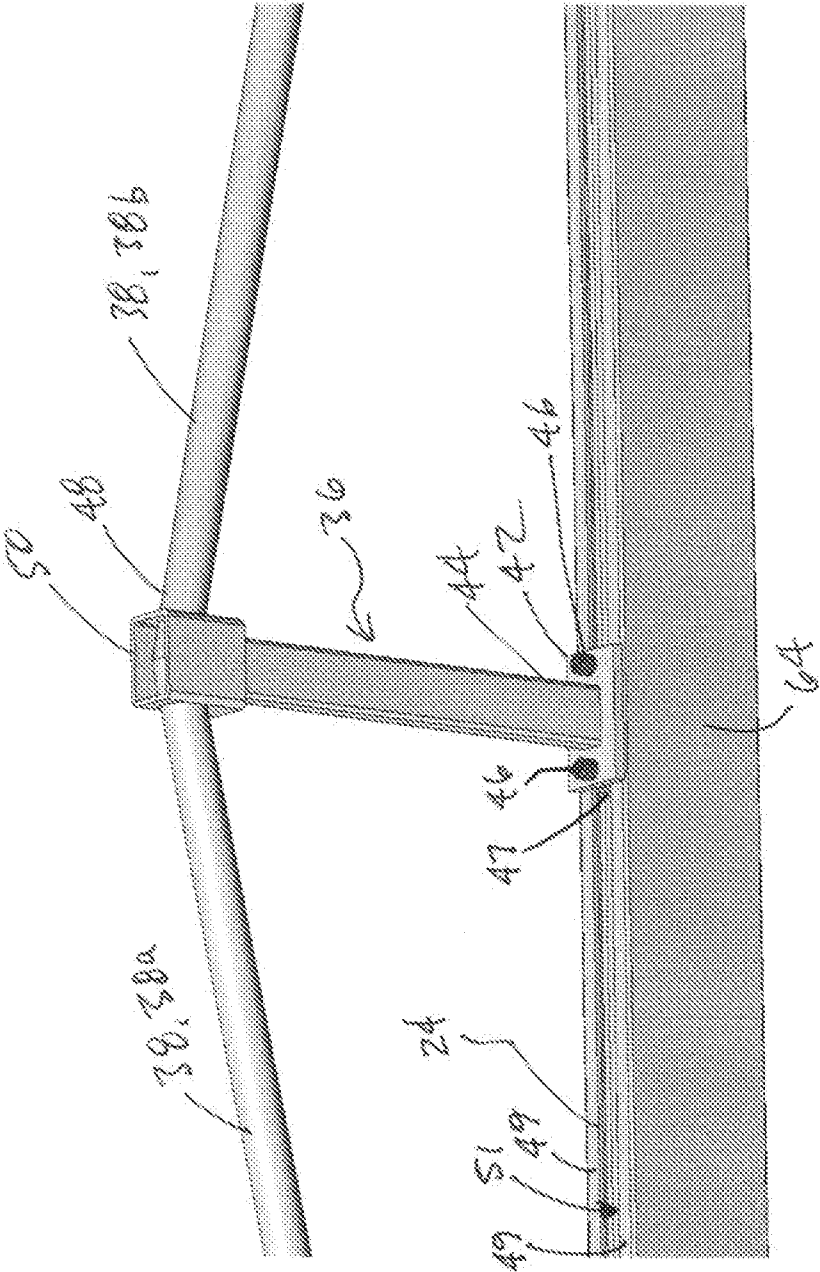

FIG 8

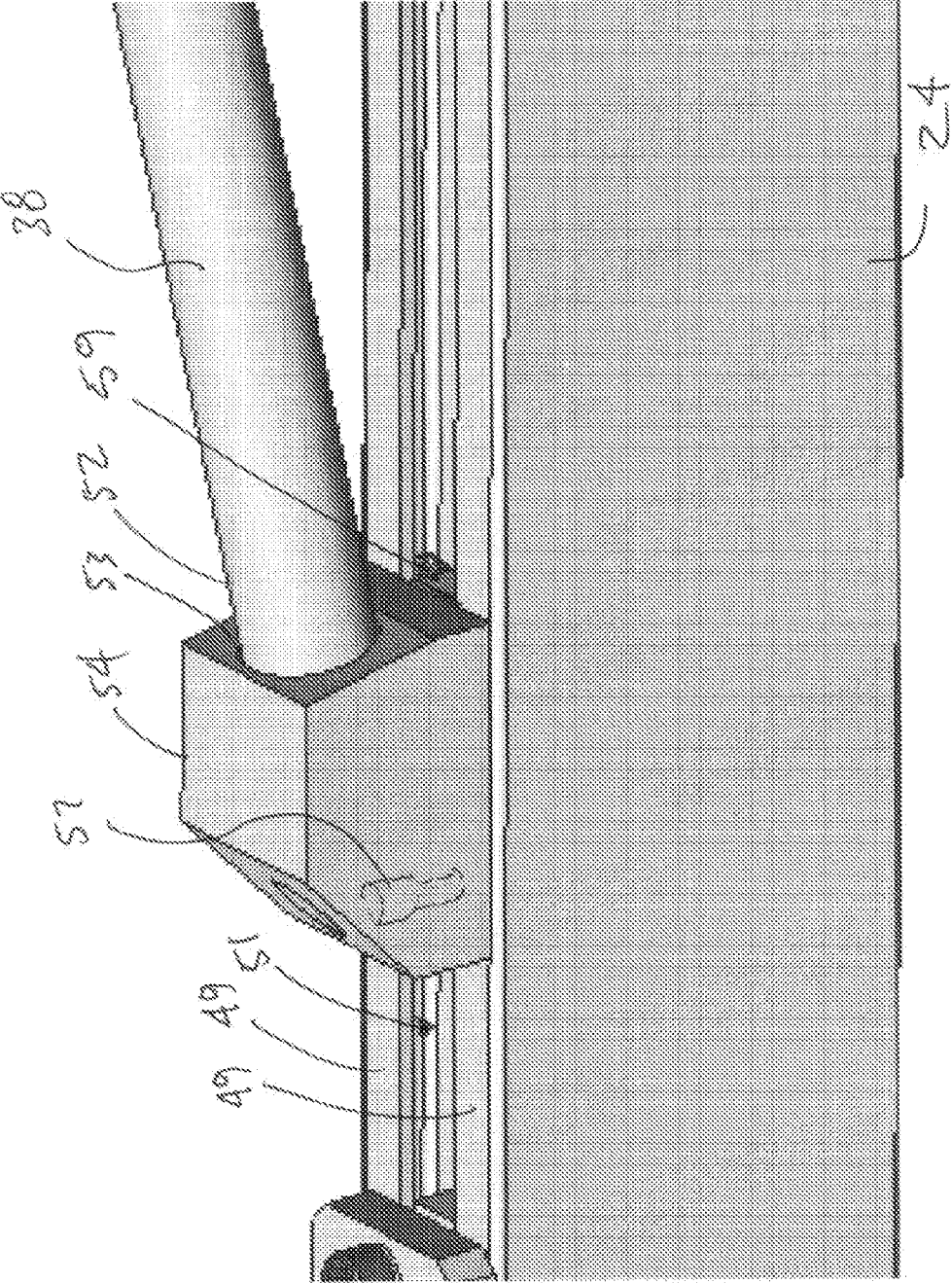

FIG 9

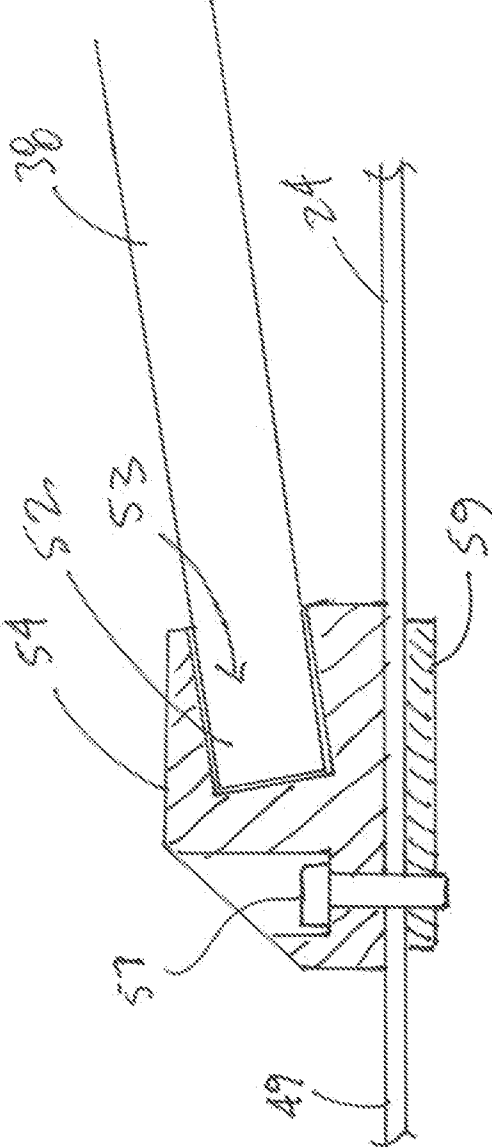

FIG 9a

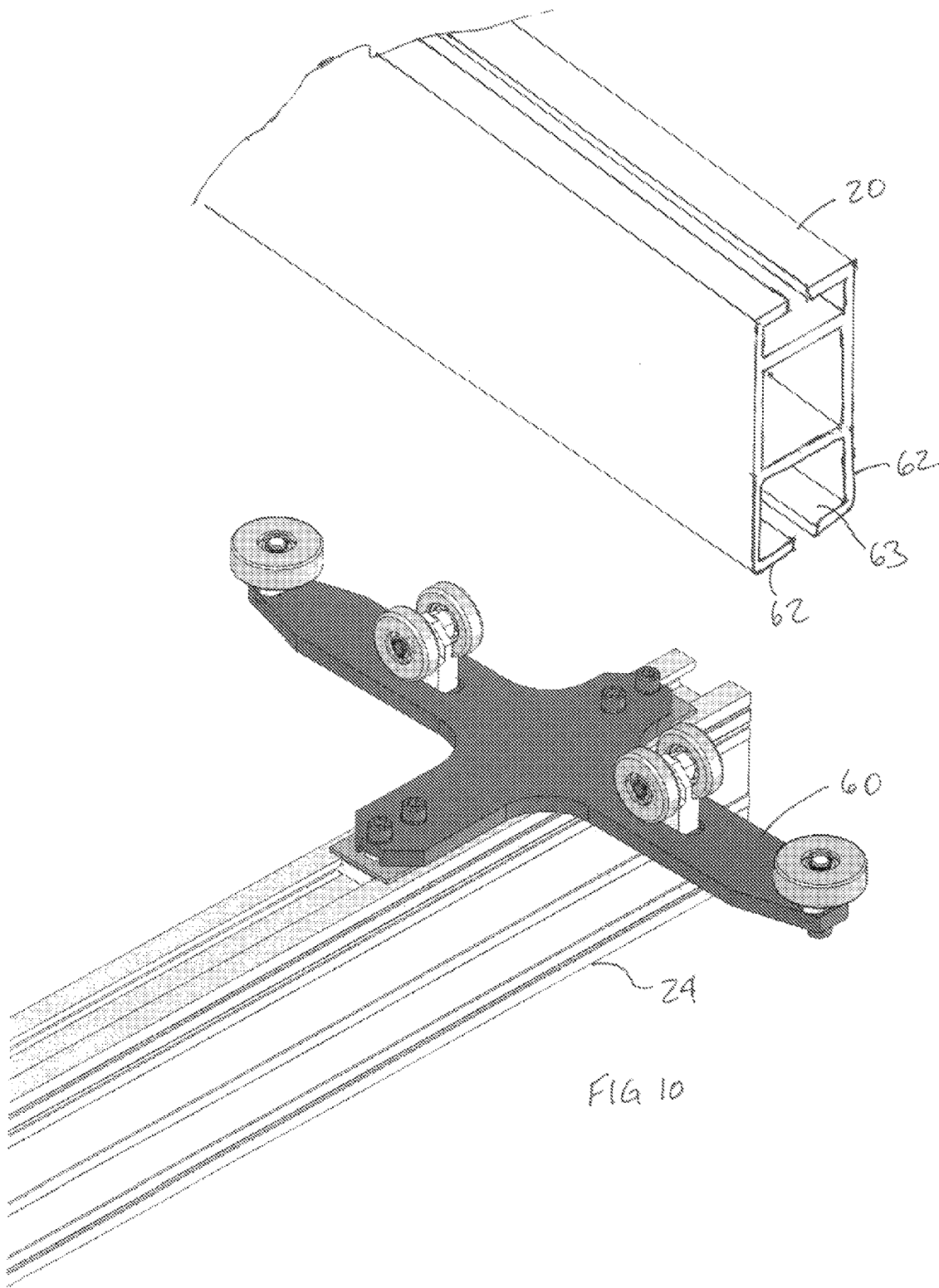

FIG 10

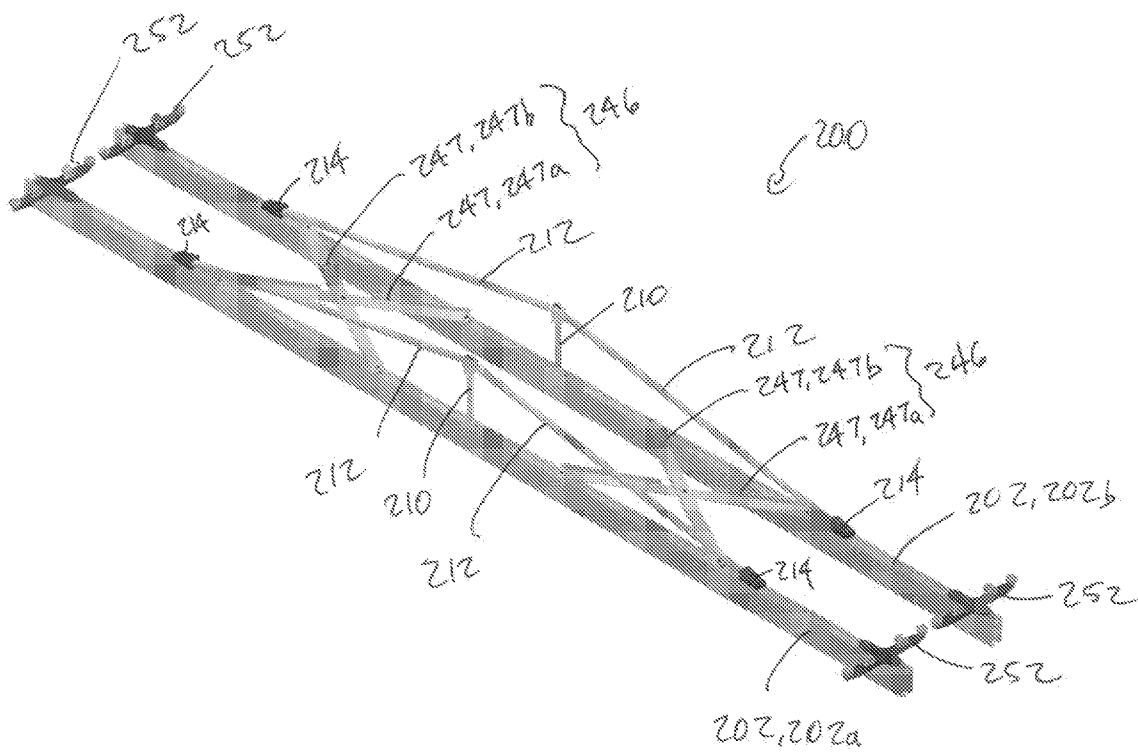

FIG 11

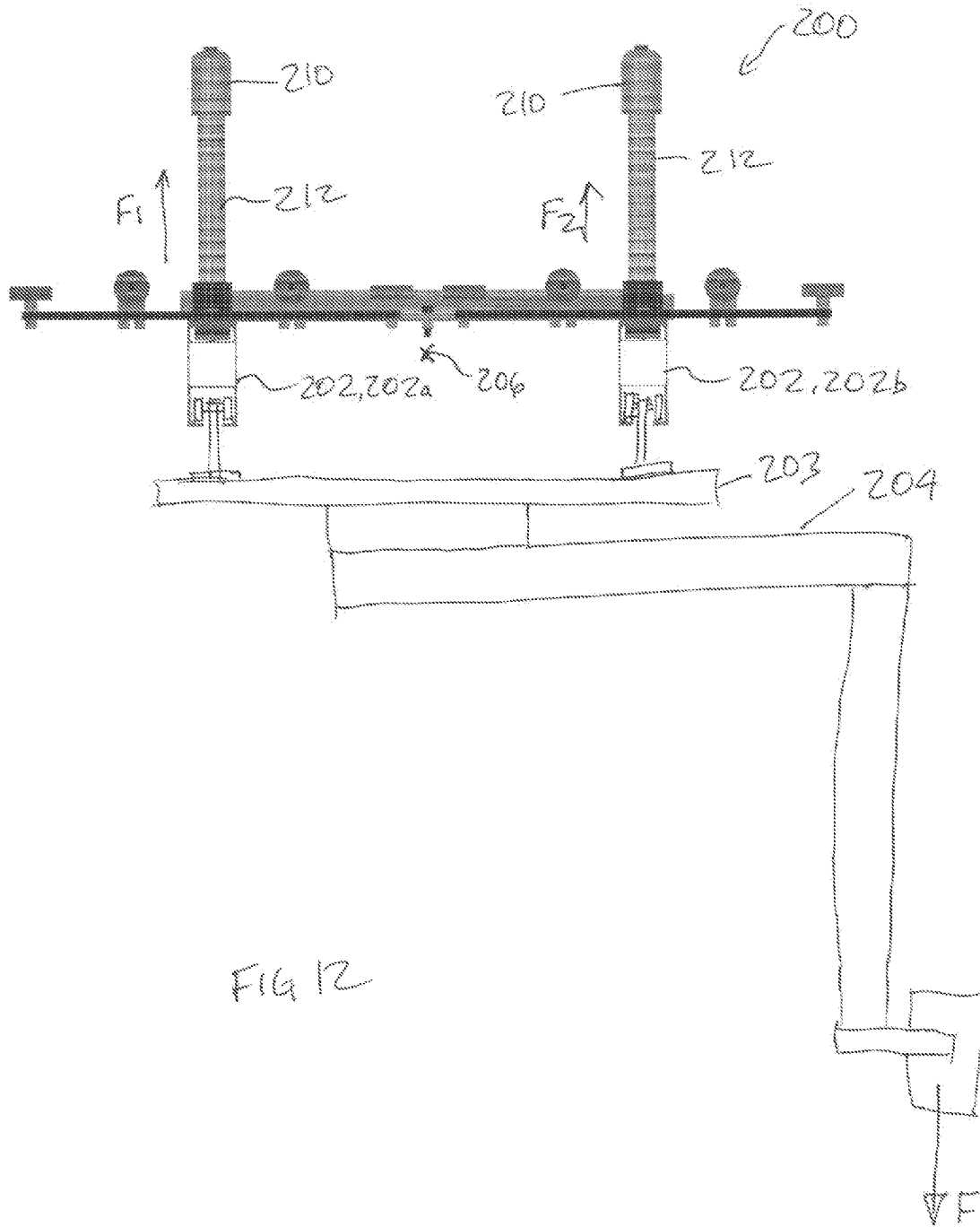

FIG 12

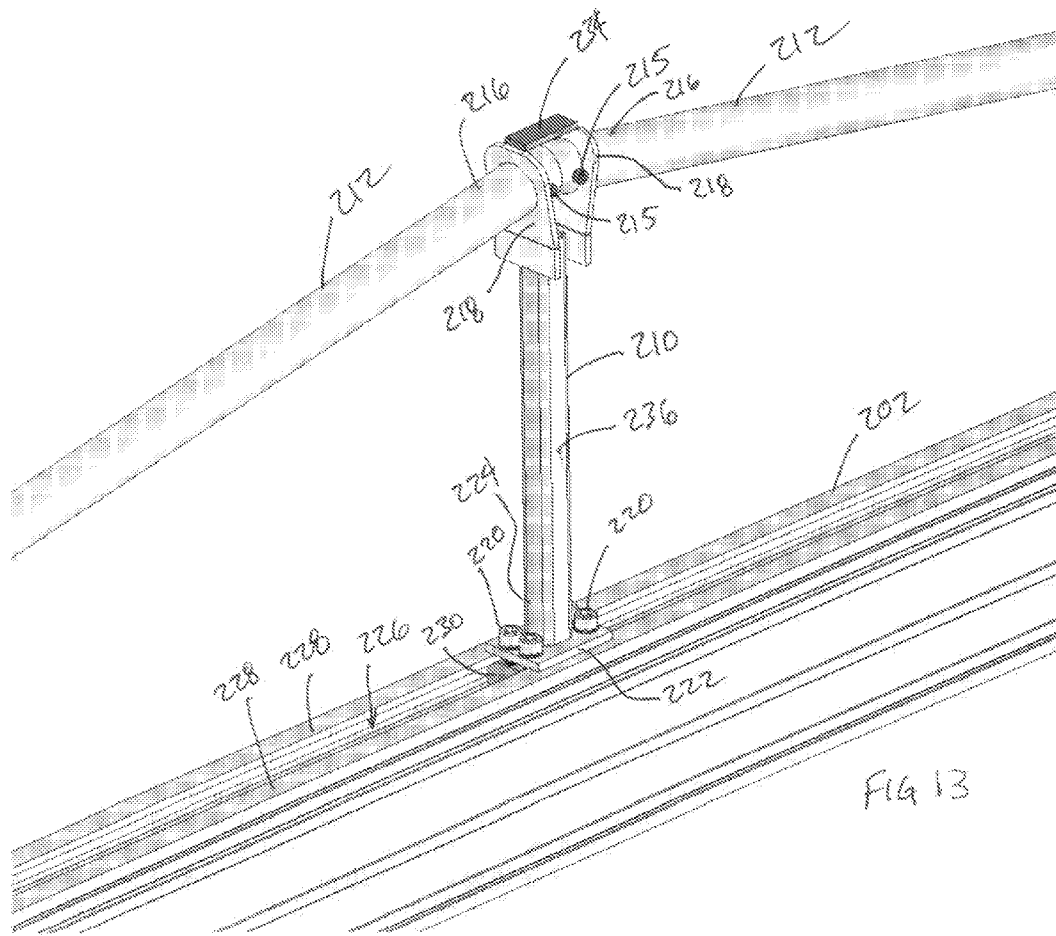

FIG 13

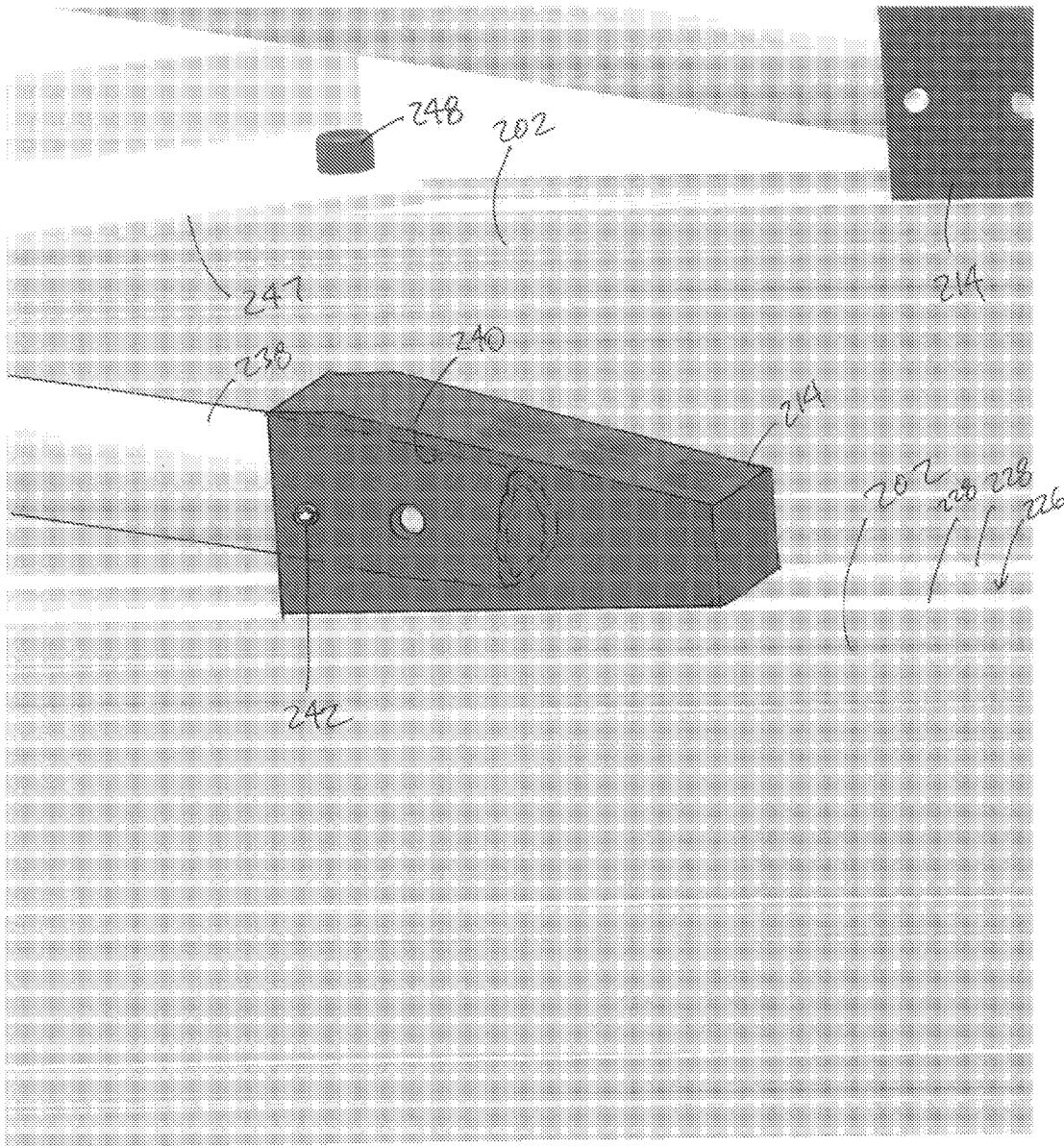
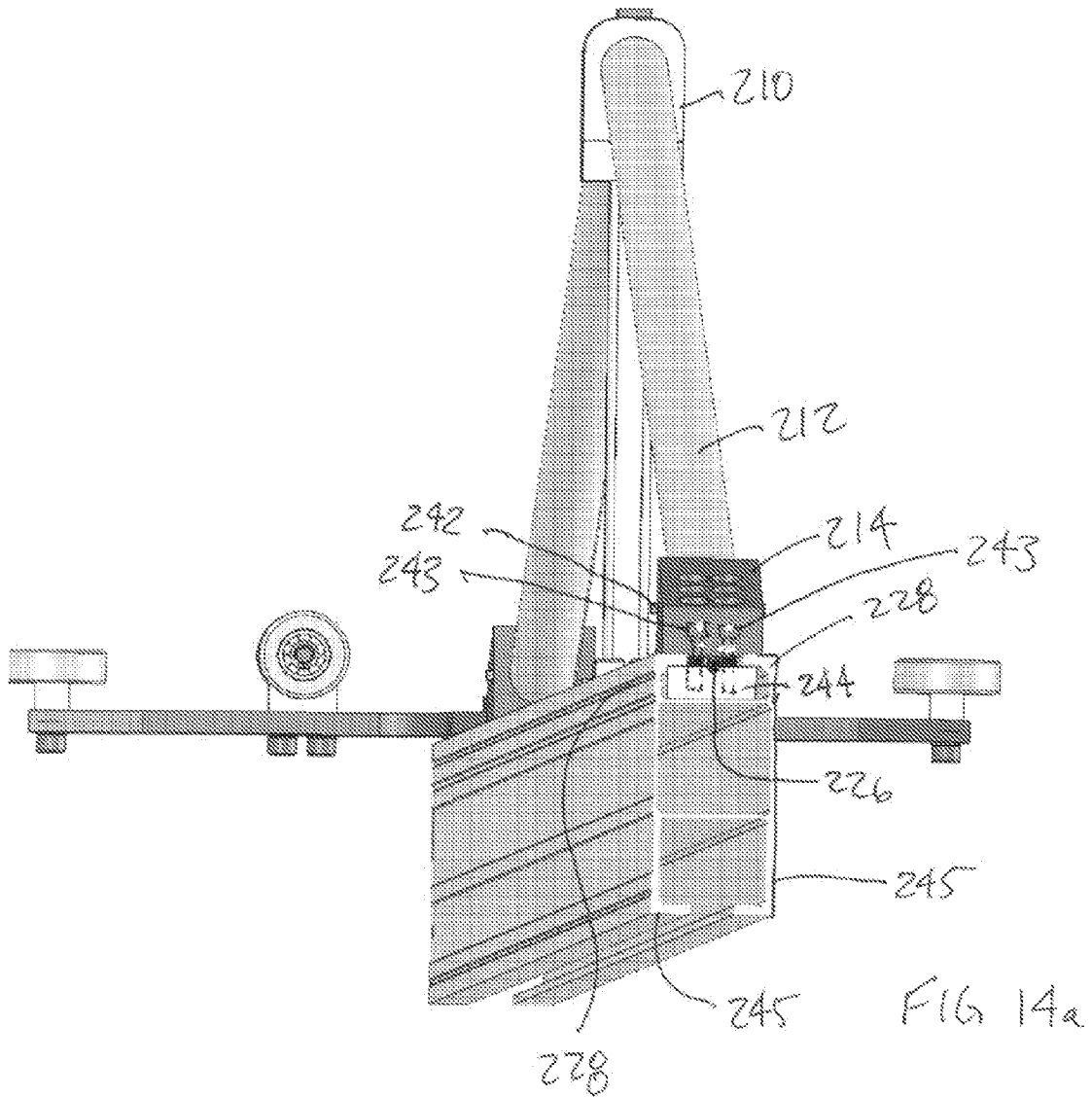

FIG 14



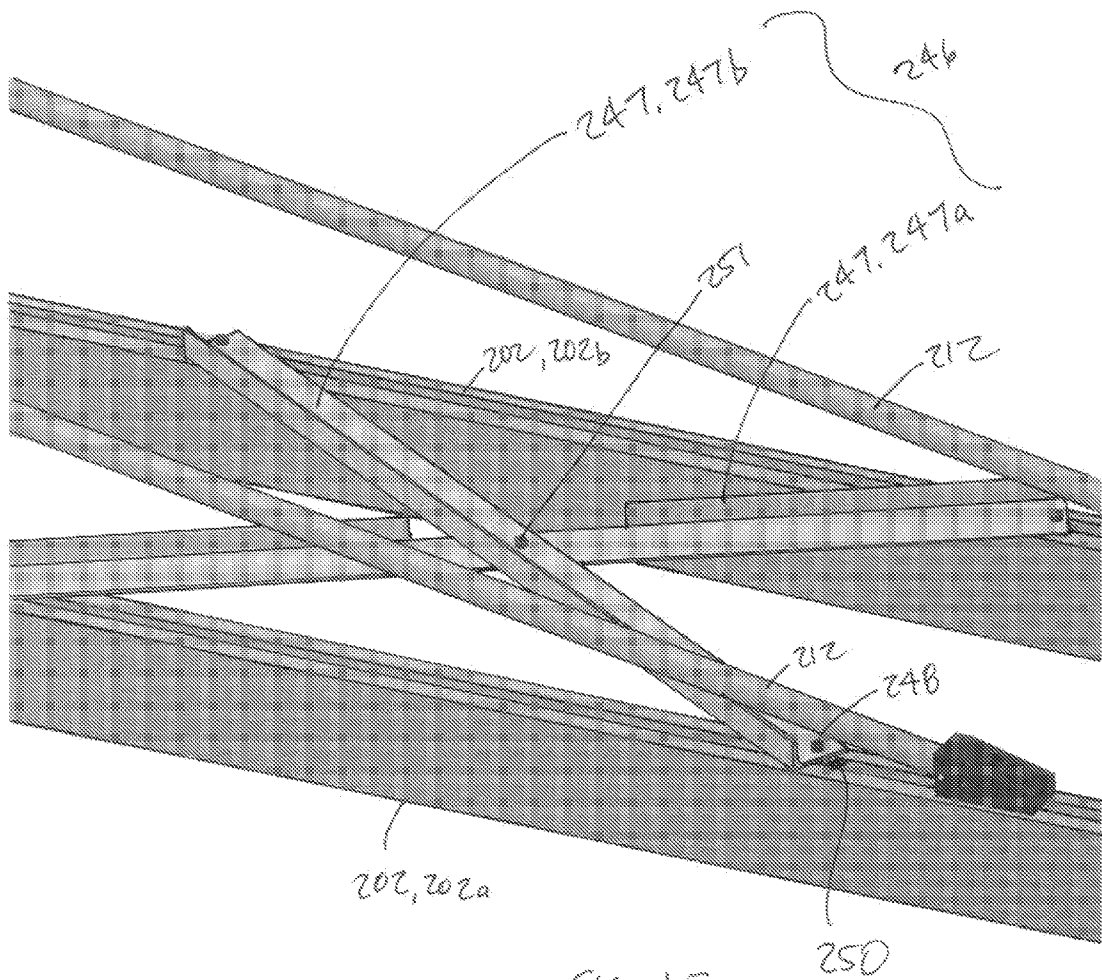

FIG 15

## 1

## SLANT-TRUSS CRANE RAIL

## FIELD OF THE INVENTION

The present invention relates to overhead cranes for use in industrial plants, and more particularly to an overhead crane that is configured to lift a load using motorized means, but wherein an operator manually pulls or pushes the lifted load to its destination.

## BACKGROUND OF THE INVENTION

Overhead cranes typically include a pair of runways, which may be mounted fixedly to the roof joists of an industrial plant, a bridge that includes one or more bridge rails which have rollers at their ends for rolling along the runway rails, and a trolley which has rollers thereon for rolling along the one or more bridge rails. A hoist or some other lifting device is provided on the trolley for lifting a load.

For cranes having capacities of more than 4000 lb, I-Beam crane rails are typically used for the one or more bridge rails and for the runways. For cranes having capacities of less than 4000 lb, enclosed track crane rails, such as the crane rail shown at 100 in FIG. 1 are typically used.

A particular category of cranes are referred to as 'light' cranes, and typically have a capacity of about 2000 lb or less. Light cranes typically do not have tractor drives on the bridge and trolley, which means that the load, once lifted off the plant floor, is moved around manually by the crane operator.

For such cranes, the weight of the bridge rails directly impacts the effort that the operator is required to exert when moving the lifted load to its destination. It is thus generally desirable to reduce the weight of the bridge rails. By reducing their weight, the effort required to move a given size of lifted load can be reduced.

A typical enclosed bridge rail is shown in FIG. 1. One method that has been used to reduce the weight of the bridge rail is to manufacture the bridge rail out of aluminum.

It would be desirable to find other ways of reducing the weight of the bridge rail particularly for light cranes that lack tractor drives for moving the bridge on the runways.

## SUMMARY OF THE INVENTION

In a first aspect, the invention is directed to an overhead crane with one or more bridge rails, that incorporates a reinforcement truss into its one or more bridge rails so as to reduce the overall mass of the one or more bridge rails. This facilitates movement of a load carried by the bridge by an operator to a destination point, particularly in embodiments wherein the one or more bridge rails do not have any bridge drive motors thereon. Reducing the mass of the bridge can increase the amount of lifted load that can comfortably be maneuvered by an operator, particularly when the bridge is manually moved along the runway. Additionally, reducing the mass of the bridge reduces the momentum associated with the bridge, which can increase the amount of control that the operator has when it is desired to stop the bridge when the load has been maneuvered to its desired destination point. The second reinforcement members may have first and second ends that are inserted into receiving apertures in the first reinforcement member and in a bracket that mounts to the bridge rail respectively. In embodiments wherein the bridge includes two rails and is capable of supporting a load in such a way as to generate a downward force that is offset from the bridge axis, the second reinforcement members may be connected to the first reinforcement member and to brackets in

## 2

such a way as to prevent the withdrawal of the second reinforcement members from the receiving apertures.

In another aspect, the invention is directed to a retrofit kit that permits the reinforcing structure described above to be easily retrofitted to existing bridge rails without the need for welding and without the need to install an inordinate quantity of fasteners.

## BRIEF DESCRIPTION OF THE DRAWINGS

The present invention will now be described by way of example only with reference to the attached drawings, in which:

FIG. 1 is an end view of a bridge rail used in a crane in accordance with the prior art;

FIG. 2 is a perspective view of an overhead crane including a bridge in accordance with an embodiment of the present invention;

FIG. 3 is a magnified end view of a bridge rail that is part of the bridge shown in FIG. 2;

FIG. 4 is a magnified end view of an alternative bridge rail that could alternatively be part of the bridge shown in FIG. 2;

FIG. 5 is a magnified end view of another alternative bridge rail that could alternatively be part of the bridge rail shown in FIG. 2;

FIG. 6 is a magnified end view of another alternative bridge rail that could alternatively be part of the bridge rail shown in FIG. 2;

FIG. 7 is a magnified end view of another alternative bridge rail that could alternatively be part of the bridge rail shown in FIG. 2;

FIG. 8 is a magnified perspective view of the mounting of a first reinforcement member to the bridge rail shown in FIG. 2;

FIG. 9 is a magnified perspective view of the mounting of a second reinforcement member to the bridge rail shown in FIG. 2;

FIG. 9a is a magnified sectional view of a bracket shown receiving the second reinforcement member in FIG. 9;

FIG. 10 is a magnified perspective view of an end of the bridge rail shown in FIG. 2 and an end of a runway rail shown in FIG. 2;

FIG. 11 is a perspective view of a double rail bridge that may be used with the overhead crane system shown in FIG. 2;

FIG. 12 is a magnified end view of the double rail bridge shown in FIG. 11 supporting a trolley and a manipulator;

FIG. 13 is a magnified perspective view of a portion of one of the bridge rails shown in FIG. 11;

FIG. 14 is a magnified perspective view showing the mounting of one of the second reinforcement members shown in FIG. 11 to one of the bridge rails shown in FIG. 11;

FIG. 14a is a magnified perspective view further showing the mounting of the second reinforcement member shown in FIG. 14 to a bracket, which is mounted to the bridge rail shown in FIG. 14; and

FIG. 15 is a magnified perspective view of the double rail bridge showing the connection between the first and second bridge rails.

## DETAILED DESCRIPTION OF THE INVENTION

Reference is made to FIG. 2, which shows an overhead crane 10 in accordance with an embodiment of the present invention. The overhead crane 10 includes a pair of runway rails 20, a bridge 14, a trolley 16 and a lifting device 18, such as a hoist. The runway rails 20 extend parallel to a generally horizontal runway axis. The bridge 14 is made up of a single

bridge rail **24** that extends parallel along a generally horizontal bridge axis that is perpendicular to the runway axis. The bridge rail **24** is rollably supported on the runway rails **20** at each end by bridge wheels **28**. The bridge **14** may be manually rollable along the runway rails **20** through the bridge wheels **28**. Alternatively a bridge drive motor may be provided (not shown) to drive the bridge **14** on the runway rails **20**. The trolley **16** is rollably supported on the bridge rail **24** by means of trolley wheels **30**. The trolley **16** may be manually rollable along the bridge rail **24**. Alternatively a trolley drive motor (not shown) may be provided to drive the trolley **16** along the bridge rail **24**.

The bridge **14** shown in FIG. 2 has a single bridge rail **24**. It will be noted that, in an alternative embodiment the bridge **14** could be provided with two or more bridge rails **24** (as shown in FIG. 11), and with a trolley that has wheels that roll along each bridge rail.

The bridge rail **24** in FIG. 2 has a pair of track flanges **32** (shown individually at **32a** and **32b**), which define a track **34** on which the trolley wheels **30** travel. The flanges **32** may be oriented towards each other so that the track **34** is an enclosed track as shown in FIG. 3. Alternatively, the flanges **32** may be oriented away from each other in which case the track **34** is an open track, as shown in FIG. 4. Other suitable shapes for the bridge rail **24** are shown in FIGS. 5, 6 and 7.

The bridge rail **24** may be made from any suitable material, such as aluminum. It will be understood that, throughout this disclosure, the term aluminum is intended to encompass both pure aluminum and aluminum alloys. By manufacturing the bridge rail **24** out of aluminum the bridge rail **24** is lighter than if it were manufactured from a material such as steel.

Referring to FIG. 2, the bridge **14** further includes a first bridge reinforcement member **36**, and two second bridge reinforcement members **38** (shown individually at **38a** and **38b**). The first and second bridge reinforcement members **36** and **38** may be made from any suitable material, such as aluminum tubing. The tubing may be round, which provides increased resistance to buckling (which is advantageous for the members that are in compression—in this case, the second members **38**).

The first bridge reinforcement member **36** may be mounted to the bridge rail **24** in any suitable way, such as by a mechanical connection. For example, as shown in FIG. 8, the first bridge reinforcement member **36** may be provided with a support flange **42** at its lower end shown at **44**. Mechanical fasteners **46** (eg. bolts) may be provided that pass through the support flange **42**, through a slot **51** between a pair of flanges **49** on the bridge rail **24**, and into a first member clamping plate **47**. When the fasteners **46** are tightened the two elements **42** and **47** together clamp the flanges **49** on the bridge rail **24** thereby fixing the first bridge reinforcement member **36** in position on the bridge rail **24**. The second flanges **49** may be referred to as reinforcement support flanges as they support the reinforcement structure **35**.

Each second bridge reinforcement member **38** has a first end **48** that may be mechanically connected to the top end (shown at **50**) of the first bridge reinforcement member **36**. For example, as shown in FIG. 8, the first ends **48** of the second reinforcement members **36** may pass through apertures **55** in the top end **50** of the first member **36**, and may abut each other so that the first end **48** of each member **36** braces the first end **48** of the other member **36**. Each aperture **55** may be referred to as a first member receiving aperture. It is alternatively possible instead to make each aperture **55** as a blind aperture that has an end wall that acts to brace the first end **48** of each second member **38**.

Each second bridge reinforcement member **38** has a second end **52** (FIGS. 9 and **9a**) that may be inserted into a receiving aperture **53** in a bracket **54** on the upper portion of the bridge rail **24**. The brackets **54** may be joined to the bridge rail **24** in any suitable way. For example, each bracket **54** may have one or more bracket mechanical fasteners **57** that pass through the bracket **54**, through the slot **51** between the reinforcement support flanges **49** and into a bracket clamping plate **59**. Tightening of the bracket mechanical fasteners **57** causes the bracket **54** and the bracket clamping plate **59** to clamp the flanges **49** on the bridge rail **24** to hold the bracket **54** in place during use. In FIG. **9a**, only one of the upper flanges **49** is shown for simplicity.

The receiving aperture **53** may be a blind aperture with an end wall to support the second end **52** of the second bridge reinforcement member **38**. The receiving aperture **53** may be referred to as a bracket receiving aperture **53**.

During use with a chain type hoist on the trolley **16**, the first member **36** is in tension and the second members **38** are in compression.

It will be noted that, because the second members **38** are in compression when in use, they do not require further fastening to the brackets **54** and to the first member **36**. Accordingly, they can be relatively simple to mount to the first member **36** and to the bridge rail **24**.

Referring to FIG. 2, the position of the first bridge reinforcement member **36** may be generally centered along the length of the bridge rail **24**. The positions of the second ends **52** of the second bridge reinforcement members **38** may be proximate the ends of the bridge rail **24** while ensuring that the brackets **54** and the reinforcement members **38** do not interfere with the rolling of the bridge **14** along the runway rails **20**.

The reinforcement members **36** and **38** together form a truss that is relatively simple and inexpensive to manufacture and that is relatively simple and quick to mount to the bridge rail **24** and is particularly advantageous in embodiments wherein the bridge rail **24** is made from aluminum. While mechanical joints are preferred for connecting the reinforcement members **36** and **38** to each other and to the bridge rail **24**, particularly when all of these components are made from aluminum, it is nonetheless contemplated that these components could alternatively be welded together.

In general, welding to an aluminum bridge rail can be difficult to achieve without weakening the parent material that makes up the bridge rail. Use of mechanical fasteners instead to join reinforcement members to a bridge rail can be relatively time consuming however. Some proposed prior art reinforcement structures do not lend themselves to be joined to an aluminum bridge rail, since they entail joining to the bridge rail at many points, which would involve either many welds, which would weaken the bridge rail, or many mechanical fasteners, which would make the bridge rail prohibitively time consuming to manufacture.

The reinforcement structure **35** provides the greatest increase in bending strength to the bridge rail **24** at the longitudinal center of the bridge rail **24**, shown at **64**, which is also where the lifting device **18** exerts the greatest bending moments on the bridge rail **24**. The amount of bending strength the reinforcement structure **35** provided to the bridge rail **24** decreases from the longitudinal center **64** toward the outer ends (which are shown at **65a** and **65b**). It will be noted that the increased resistance to bending provided by the reinforcement members **36** and **38** generally matches the bending moment profile of bending moments exerted by the lifting device **18** on the bridge rail **24** at different points along the bridge rail **24** while holding a load. As a result, the reinforce-

ment members **36** and **38** are efficient in the sense that they provide the most strengthening to the portion of the bridge rail **24** that incurs the highest bending moments (ie. the middle of the bridge rail **24**).

By providing the reinforcement members **36** and **38**, the bridge rail **24** can be made lighter than would otherwise be required if it consisted only of the bridge rail **24**, for holding a selected size of load. This reduces the overall amount of weight that an operator must push or pull in embodiments wherein bridge drive motors are not provided. This is also advantageous in embodiments that do include drive motors for the bridge since the bridge drive motor (or motors) have less work to do to move the lighter bridge along the runway rails.

Another advantage to this configuration is that the bridge **14** has less momentum associated with it, and so the operator has a greater degree of control over stopping the bridge **14** after rolling the bridge **14** to a selected point along the runway rails **20**. This is particularly relevant for bridges **14** that have relatively long spans, which are necessarily heavier and which have larger bending moments associated therewith resulting from the greater distances between their points of support on the runway rails and the load.

Referring to FIG. 10, the bridge **14** further includes a rolling structure **60** mounted at each end of the bridge rail **24** by clamping the upper flanges **49**, in similar fashion to the clamping of the flanges **49** by the first member **36** and by the brackets **54**. The rolling structure **60** rolls along flanges shown at **62** on the runway rails **20**.

The trolley **16** may be made substantially from aluminum. Other materials may also be used in addition to or instead of aluminum.

The lifting device **18** may be a hoist or may be some other suitable type of lifting device.

Other configurations of the reinforcement structure **35** are possible, which provide increased bending strength to the bridge rail **24**, while keeping the number of mounting points between the reinforcement structure **35** and the bridge rail **24** relatively low, and while generally matching the bending moment profile exerted on the bridge rail **24** by the load being held by the lifting device **18** at different positions along the length of the bridge rail **24**. In one exemplary alternative configuration, two first reinforcement members **36** may be provided, each of which is connected to a second member **38**. The two members **36** may optionally share a common support flange, or may optionally have separate support flanges. The two first members **36** can be positioned proximate each other at the longitudinal center **64** of the bridge rail **24** such that the increase in bending resistance to the bridge rail **24** has roughly the same shape as it did with one centrally positioned first member **36**. Alternatively, the two first members **36** can be spaced from each other, and optionally a third reinforcement member can extend between them (eg. generally horizontally between their upper ends). In another alternative, a single centrally positioned first member **36** may be provided, and smaller third members may be provided partway along the length of each second member **38** extending vertically between the second member and the bridge rail **24** to increase the buckling resistance of the second member **38**.

Referring to FIG. 2, the runway rails **20** may be made similarly to the bridge rail **24** in that they each include flanges **62** that define a track **63**. Each runway rail **20** may further be strengthened by a reinforcement structure **72** which increases the bending resistance of the runway rail **20** so as to resist bending forces from the bridge **14**. In the exemplary embodiment shown in FIG. 2, the reinforcement structure **72** comprises a first runway reinforcement member **78** which extends

upwardly from the longitudinal center of the runway rail **20**, and two second reinforcement members **80** which extend between the upper end of the first member **78** and the runway rail **20** proximate the ends **76a** and **76b**. By strengthening the bending resistance of the runway rail **20** in this way, the runway rail **20** itself may be made smaller than it would need to be if the reinforcement structure **72** were omitted. As a result, the overall weight and cost of the runway rail **20** may be reduced relative to a runway rail that did not have a reinforcement structure thereon. It will be noted, however, that reducing the weight of the runway rail, while advantageous, does not facilitate the movement of a lifted load to a destination point, since the runway rails **20** remain fixed in place throughout any operation with the overhead crane. The runway rails **20** may be made from any suitable material, such as steel, or aluminum.

Reference is made to FIG. 11, which shows a double rail bridge **200** which can be used as part of the overhead crane **10** instead of the single rail bridge **14** (FIG. 1). The double rail bridge **200** has first and second bridge rails **202** (shown individually at **202a** and **202b**), which together support a trolley **203** that may hold a lifting device such as a manipulator **204**. During use of the manipulator **204** forces may be applied to the bridge **200** that are laterally offset from the longitudinal centerline of the bridge **200** (which is shown at **206** as a point in FIG. 12). An exemplary offset force is shown at F. The force F generate reaction forces F1 and F2 on the bridge **200**. As shown the force F generates an upwardly directed force F1 on the bridge rail **202a** and a downwardly directed force F2 on the bridge rail **202b**. Each bridge rail **202** has a reinforcement structure **208** thereon that includes a first bridge reinforcement member **210** and two second reinforcement members **212**. Brackets **214** may be provided to connect the second ends of the second reinforcement members **212** to the bridge rail **202**.

It will be noted that, for the bridge rail **202a**, the first reinforcement member **210** is under compression and the two second reinforcement members **212** are under tension. Conversely, the first reinforcement member **210** on the second bridge rail **202b** is under tension and the second reinforcement members **212** on the second bridge rail **202b** are under compression, in similar manner to the single rail bridge **14** shown in FIG. 2. It will be understood that in situations during use of the crane **200**, the manipulator **204** may be positioned on the other side of the centerline **206** and so the tension and compression in the members of the reinforcement structures **208** on the two bridge rails **202a** and **202b** will be reversed.

In order to prevent the second reinforcement members **212** from withdrawing from the first reinforcement member **210**, the second reinforcement members **212** have lateral extending first end retaining pins **215** that pass through their first ends, shown at **216**. The pins **215** engage an inboard face of a wall **218** on the first reinforcement member **210** to prevent the withdrawal of the second reinforcement member **212** therefrom. The pins **215** may be in the form of threaded fasteners (e.g. a bolt and nut).

Referring to FIG. 13, the first reinforcement member **210** may be mounted to the bridge rail **202** in any suitable way, such as by use of one or more threaded fasteners **220** that pass through a support flange **222** at the bottom end **224** of the first reinforcement member **210**. The threaded fasteners **220** pass through a slot **226** between first and second reinforcement support flanges **228** on the bridge rail **202**, and pass into a threaded aperture in a clamping plate **230** so that the support flange **222** and the clamping plate **230** together clamp the flanges **228** on the bridge rail **202**.

Referring to FIG. 13 still, the walls 218 of the first reinforcement member 210 each have a first member receiving aperture 232 there in for receiving the first ends 216 of the second reinforcement members 212. The walls 218 may be connected to each other by a bar 234 that is welded (or is otherwise connected) across their respective tops. The walls 218 may each be connected to the main body shown at 236 of the first reinforcement member 210 by welds or by any other suitable type of connection. It can be seen that the space between walls 218 is open in the lateral direction so as to permit easy access for installing the first end retaining pins 215 and for visually ensuring that the first ends 216 are positioned suitably to brace each other.

Referring to FIG. 14, each second reinforcement member 212 has a second end 238 that extends into a bracket receiving aperture 240 in one of the brackets 214. A laterally extending second end retaining pin 242 extends laterally through the bracket 214 and through the second end 238 of the second reinforcement member 212. The pin 242 may be any suitable type of pin, such as a spring pin.

Referring to FIG. 14a, each bracket 214 may connect to the bridge rail 202 by means of mechanical fasteners 243 which pass through the bracket 14, through the slot 226 between the upper flanges 228 on the bridge rail 202, and into a threaded aperture in a clamping plate 244 so as to clamp the flanges 228.

As can be seen in FIG. 14a, the bridge rails 202 may each have a similar profile to the bridge rail 24. The bridge rails 202 may have any suitable profile, such as any of the profiles shown in FIGS. 3-7. The bridge rails 202 may thus have track flanges 245, which are similar to the track flanges 32 and which together define a track.

Referring to FIGS. 11 and 15, one or more X-bracing structures 246 may be provided between the first and second bridge rails 202a and 202b so as to structural connect them. Each X-bracing structure 246 may be made up of first and second cross members 247, shown individually at 247a and 247b. Each cross member 246 may be connected at its ends to the bridge rails 202 by means of threaded fasteners and clamping plates at shown at 248 and 250 in FIG. 15. The cross members 247a and 247b are also connected to each other at their respective middles by pin connection 251.

Referring to FIG. 11, each of the bridge rails 202 has a rolling structure 252 at each end that may be similar to the rolling structure 60 (FIG. 10).

It will be noted that the reinforcement structures 35 and 208 can easily be retrofitted to existing bridge rails 24, 202 in an existing overhead crane 10, 200, particularly where the overhead crane has upper flanges that can be used as reinforcement support flanges. As a result, the bridge rails can be strengthened significantly so as to be capable of supporting increased loads. It will further be noted that the reinforcement can be provided by the structure 35, 208 without the need for welding elements to the rails 24, 202, without drilling through the rails 24, 202 and without requiring an inordinate number of fasteners.

It is optionally possible to provide the retaining pins 215 and 242 on a single rail bridge, such as the bridge 14, for use in situations where the single rail bridge 14 will be subjected to upward forces from the lifting member.

While the above description constitutes a plurality of embodiments of the present invention, it will be appreciated that the present invention is susceptible to further modification and change without departing from the fair meaning of the accompanying claims.

The invention claimed is:

1. An overhead crane, comprising:

first and second runway rails that extend parallel to a generally horizontal runway axis;

a bridge that extends along a bridge axis that is generally horizontal and perpendicular to the runway axis and that is movable on the runway rails along the runway axis, wherein the bridge includes a bridge rail having first and second ends and rolling structures at the first and second ends which are rollably supported on the first and second runway rails;

a trolley having a plurality of trolley wheels thereon permitting movement of the trolley along the bridge rail; and

a lifting device for holding a load, wherein the lifting device is supported by the trolley,

wherein the bridge further includes

a single first bridge reinforcement member supporting the bridge rail and extending upwardly substantially from the longitudinal center of the bridge rail, the first bridge reinforcement member having a lower end mechanically connected to the bridge rail, and an upper end, the first bridge reinforcement member loaded under tension,

a single pair of second bridge reinforcement members also supporting the bridge rail and extending between the upper end of the first bridge reinforcement member and mechanically connected to the bridge rail proximate the first and second outer ends, the second bridge reinforcement members loaded in compression, and

the bridge reinforcement members providing the greatest increase in bending strength at the longitudinal center of the bridge rail.

2. The overhead crane as claimed in claim 1, wherein the bridge rail comprises aluminum.

3. The overhead crane as claimed in claim 1, wherein the bridge rail is manually rollable along the runway rails by means of bridge wheels.

4. The overhead crane as claimed in claim 1, wherein for each runway rail, the runway includes:

a first runway reinforcement member extending upwardly from the runway rail, the first runway reinforcement member having a lower end connected to the runway rail, and an upper end; and

two second runway reinforcement member extending between the upper end of the first runway reinforcement member and the runway rail proximate the first and second outer ends.

5. The overhead crane as claimed in claim 1, wherein the first bridge reinforcement member has first and second opposed first member receiving apertures at the upper end, and wherein the bridge rail further includes first and second brackets positioned respectively at the first and second outer ends of the bridge rail, each bracket having a bracket receiving aperture that generally faces one of the first member receiving apertures, and wherein each second bridge reinforcement member has a first end that extends into one of the first member receiving apertures and a second end that extends into the bracket receiving aperture on one of the brackets.

6. The overhead crane as claimed in claim 5, wherein the first ends of the two second bridge reinforcement members abut each other.

7. The overhead crane as claimed in claim 6, wherein the first bridge reinforcement member and the brackets are mounted to the bridge via mechanical fasteners.

9

8. The overhead crane as claimed in claim 7, wherein the bridge rail includes a pair of track flanges which form a track for a trolley, and wherein the bridge rail further includes a pair of reinforcement support flanges, and

wherein at least one fastener passes through each of the first bridge reinforcement member and the brackets and into an associated clamping plate to clamp the reinforcement support flanges.

9. The overhead crane as claimed in claim 8, wherein the at least one fastener comprises a threaded fastener that removably connects to the respective clamping plate.

10. The overhead crane as claimed in claim 5, wherein the first end of each second bridge reinforcement member is retained within the first end receiving aperture by a first end retaining pin, and the second end of each second bridge reinforcement member is retained within the second end receiving aperture by a second end retaining pin.

11. An overhead crane, comprising:

first and second runway rails that extend parallel to a generally horizontal runway axis;

a bridge that extends along a bridge axis that is generally horizontal and perpendicular to the runway axis and that is movable on the runway rails along the runway axis, wherein the bridge includes first and second bridge rail that are connected to each other and that are generally parallel, wherein each bridge rail has first and second ends and rolling structures at the first and second ends which are rollably supported on the first and second runway rails;

a trolley that is rollably supported on the first and second bridge rails; and

a lifting device for holding a load, wherein the lifting device is supported by the trolley and is capable of lifting loads in such a way as to generate downward forces that are offset laterally from the bridge axis,

wherein, for each bridge rail, the bridge further includes

a single first bridge reinforcement member supporting the bridge rail and extending substantially upwardly from the longitudinal center of the bridge rail, the first bridge reinforcement member having a lower end mechanically connected to the bridge rail, and an upper end, the first bridge reinforcement member loaded under tension,

a single pair of second bridge reinforcement members also supporting the bridge rail and extending between the upper end of the first bridge reinforcement member and mechanically connected to the bridge rail proximate the first and second outer ends, the second bridge reinforcement members loaded in compression, and

the bridge reinforcement members providing the greatest increase in bending strength at the longitudinal center of the bridge rail,

wherein the first bridge reinforcement member has first and second opposed first member receiving apertures at the upper end, and wherein the bridge rail further includes first and second brackets positioned respectively at the first and second outer ends of the bridge rail, each bracket having a bracket receiving aperture that generally faces one of the first member receiving apertures, and wherein each second bridge reinforcement member has a first end that extends into one of

10

the first member receiving apertures and a second end that extends into the bracket receiving aperture on one of the brackets, and

wherein the first end of each second bridge reinforcement member is retained within the first end receiving aperture by a first end retaining pin, and the second end of each second bridge reinforcement member is retained within the second end receiving aperture by a second end retaining pin.

12. A retrofit kit for strengthening an overhead crane, wherein the overhead crane includes first and second runway rails that extend parallel to a generally horizontal runway axis, a bridge that extends along a bridge axis that is generally horizontal and perpendicular to the runway axis and that is movable on the runway rails along the runway axis, wherein the bridge includes a bridge rail having first and second ends and rolling structures at the first and second ends which are rollably supported on the first and second runway rails, a trolley having a plurality of trolley wheels thereon permitting movement of the trolley along the bridge rail, and a lifting device for holding a load, wherein the lifting device is supported by the trolley, wherein the bridge rail includes a pair of track flanges which form a track for a trolley and wherein the bridge rail further includes a second pair of flanges, wherein the retrofit kit includes:

a single first bridge reinforcement member supporting the bridge rail and extending upwardly substantially from the longitudinal center of the bridge rail, the first bridge reinforcement member having a lower end mechanically connected to the bridge rail, and an upper end, the first bridge reinforcement member loaded under tension,

a single pair of second bridge reinforcement members also supporting the bridge rail and extending between the upper end of the first bridge reinforcement member and mechanically connected to the bridge rail proximate the first and second outer ends, the second bridge reinforcement members loaded in compression, and

the bridge reinforcement members providing the greatest increase in bending strength at the longitudinal center of the bridge rail,

wherein the first bridge reinforcement member is the only first bridge reinforcement member on the bridge rail and wherein the two second bridge reinforcement members are the only two second bridge reinforcement members on the bridge rail, and

wherein at least one fastener passes through each of the first bridge reinforcement member and the brackets and into an associated clamping plate to clamp the second flanges.

13. The retrofit kit as claimed in claim 12, wherein the at least one fastener is a threaded fastener that removably connects to the respective clamping plate.

14. The overhead crane as claimed in claim 1, wherein the second bridge reinforcement members are unfastened with respect to the first bridge reinforcement member.

15. The overhead crane as claimed in claim 11, wherein the second bridge reinforcement members are unfastened with respect to the first bridge reinforcement member.

16. The retrofit kit as claimed in claim 12, wherein the second bridge reinforcement members are unfastened with respect to the first bridge reinforcement member.

\* \* \* \* \*