

Dec. 15, 1959

B. B. VAN IPEREN

2,917,657

KLYSTRON TUBE

Filed March 7, 1957

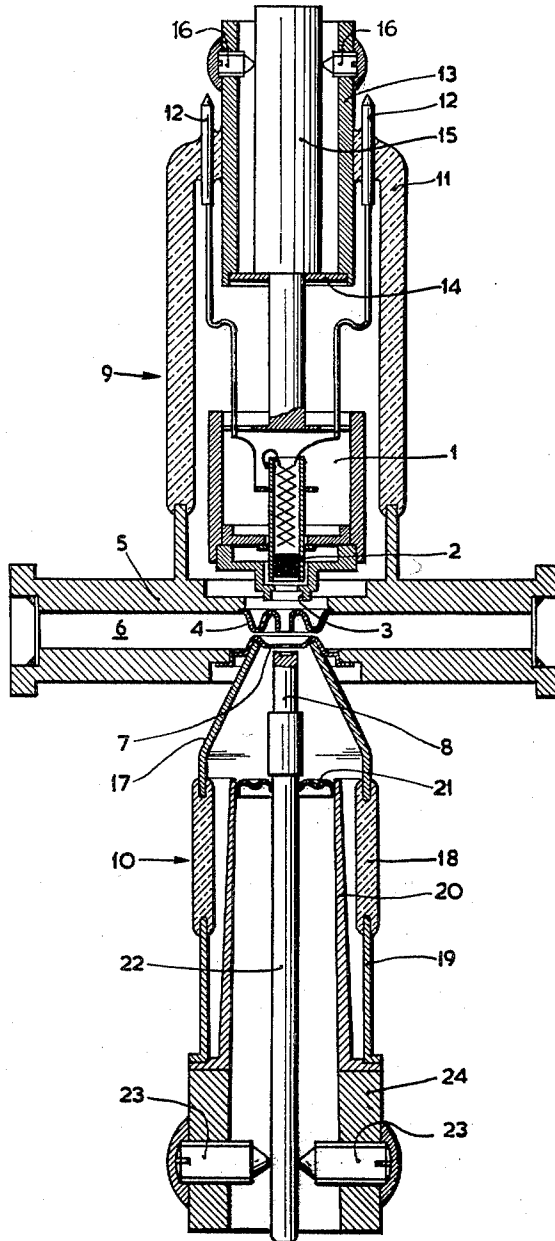

INVENTOR

BERNARDUS BASTIAAN VAN IPEREN

BY

*Frank R. Infante*

AGENT

1

2,917,657

## KLYSTRON TUBE

Bernardus Bastiaan van Iperen, Eindhoven, Netherlands, assignor to North American Philips Company, Inc., Irvington on Hudson, N.Y.

Application March 7, 1957, Serial No. 644,634

Claims priority, application Netherlands March 17, 1956

2 Claims. (Cl. 315—5.19)

This invention relates to klystron tubes and particularly to reflex klystron oscillators operating at extremely high frequencies which have not been obtainable heretofore. These frequencies are of the order of 75,000 mc/s.

At such high frequencies the spacing between electrodes in the tube becomes so small that it is impossible to use ordinary production techniques in assembling the parts. There is simply no room to allow a jig to be placed between adjacent electrodes, and furthermore, the small spacing between electrodes precludes the use of built-in dielectric spacers because the voltage gradient through the spacer would be exorbitantly high and the tolerance to which the spacers would have to be built would be almost impossible, or at least impractical, to achieve.

The primary object of the invention is to provide a klystron which will produce substantial power output at extremely high frequencies of the order of 75,000 mc/s. A second object is to provide a klystron which is capable of operating at frequencies in this range and which can yet be built at a reasonable expense and can be reproduced in any desired quantity.

Other objects will be apparent from the following specification together with a drawing in which the only figure is a cross sectional view of a klystron constructed according to the principles of the invention.

Electrically, the klystron consists of an electron gun, a resonant cavity having a pair of apertures through which the beam from the gun passes, and a repeller electrode. The present invention consists in the mechanical arrangement of these components, which are known per se. The resonant cavity is constructed as an integral part of a relatively stiff-walled evacuated chamber and the electron gun is supported by an elongated support member that passes through, and is sealed to, a diaphragm which is at least a little more flexible than the stiff walls. The end of the support member external to the evacuated chamber is constrained by clamping means secured to the stiff walls, so that, by manipulation of the clamping means, the elongated support member may be pivoted about a point determined by the diaphragm, thereby moving the electron gun within the evacuated chamber so as to align the gun with the apertures in the resonant cavity.

This structure, which allows the electron gun to be precisely positioned after the klystron has been constructed and evacuated, eliminates the necessity for attempting the almost-impossible task of achieving precise positioning of the parts during construction and permits the spacing between components to be greatly reduced, with a concomitant increase in operating frequency, over what has hitherto been possible. The external positioning arrangement may also be applied to the repeller electrode, which is located on the far side of the resonant cavity from the electron gun.

In the drawing reference numeral 1 designates the electron gun structure consisting of the cathode 2 and a control electrode, or Wehnelt cylinder, 3. The electron beam formed by the gun is directed through an aperture 4 in a wall 5, of a resonant cavity 6 and through a sec-

2

ond, slightly flexible apertured membrane 7 in the opposite wall of cavity 6. In accordance with the usual principles of reflector klystrons, the electrons are then reflected by a reflector electrode 8 so as to complete the necessary oscillatory movement.

The resonant cavity 6 forms the backbone of the klystron and carries a tubular extension 9 on one side in which the electron gun 1 is mounted and a tubular extension 10 on the other side in which the reflector electrode 8 is mounted.

Since, in the operation of the klystron, a voltage difference of the order of 2200 to 2500 volts may exist between the electron gun and the resonant cavity, some means must be provided in the interconnecting mechanical structures to insulate the gun from the cavity. It is convenient to make this insulation in the form of a tubular glass section 11 of the tubular extension 9. This glass section 11 also provides a place for the connecting pins 12 to be mounted. The outer end of the glass section 11 is sealed to the midportion of a relatively stiff metal tubular member 13, the inner, or reentrant, end of which is closed by a slightly flexible diaphragm 14 which, in turn, is sealed to a central point of an elongated support member 15 that carries on its inner end the electron gun 1. The designation of "central point" does not, of course, mean the mathematical center of member 15 but merely some point substantially in from each end. Clamping means in the form of a plurality of set screw 16 spaced around the outer end of the tubular member 13 exert a lateral pressure on the outer end of the support member 15.

The other tubular extension 10 in which the repeller electrode 8 is mounted is basically the same as the tubular extension 9 in which the electron gun 1 is mounted. However, instead of being affixed directly to the stiff wall of the resonant cavity 6, the tubular extension 10 includes a reduced diameter part 17 that is sealed to the slightly flexible apertured membrane 7 so that, as is common in reflex klystrons, this membrane may be distorted by being pushed in or pulled out slightly to vary the spacing between it and the aperture 4 and thereby to vary the tuning of the klystron. The insulating section of extension 10 is a piece of glass tubing 18 which is sealed at one end to the conical section 17 and at the other end to another metallic section 19. This section 19, in turn, is sealed to a reentrant member 20, the inner end of which is closed by a diaphragm 21 which is relatively flexible with respect to the other components of tubular section 10. The diaphragm 21 is sealed to a support rod 22 on which the repeller electrode 8 is mounted and the outer end of which is clasped between a plurality of set screws 23 that are held in a tubular member 24 affixed to the reentrant member 20. It will be understood that the invention is not limited to the specific components illustrated in making up the tubular sections 9 and 10; a large variety of alternative arrangements will readily occur to one skilled in the art.

After the klystron has been constructed, using reasonable manufacturing tolerances, the electron gun 1 and the repeller electrode 8 must be aligned with respect to the apertures in the resonant cavity 6. The reason for this alignment and the difficulty of achieving it directly by attention to manufacturing tolerances will readily be apparent when it is considered that the diameter of the aperture in membrane 7 is of the order of  $\frac{1}{4}$  of a mm. and the spacing between the reflector electrode 8 and the membrane 7 is of the order of  $\frac{1}{6}$  of a mm. However, by virtue of the customary manufacturing tolerances it can be assumed that at least some of the electrons of the beam formed by applying voltages to the electron gun 1 will find their way through the apertures to the repeller electrode 8 and will produce oscillations in the

resonant cavity 6. These oscillations may be measured by microwave measuring instruments which are not shown. By adjusting the set screws 16 and the set screws 23 the power output of the klystron may be maximized, thus indicating proper alignment of the electron gun 1 and the repeller electrode 8. The adjusting process need be carried out only once, after which the set screws 16 and 23 may be sealed, by cement or other suitable means, to the tubular members 13 and 24, respectively, so that the electron gun 1 and the reflector electrode 8 remain properly positioned laterally for the life of the klystron.

Nominal operation voltages with respect to the cathode in the electron gun 1 are as follows:

- Control grid minus 30 to minus 60 volts
- Resonant cavity 2200 to 2500 volts
- Repeller electrode 100 to 500 volts.

The voltages are only illustrative and may vary with modifications in the design.

While the invention has been tested at frequencies of the order of 75,000 mc./s. (corresponding to wave lengths of 4 mm.) at a power output of the order of 40 mw. and at lower frequencies of about 37,000 mc./s. and 25,000 mc./s. (corresponding to wave lengths of 8 mm. and 12 mm. respectfully) the invention is not limited to use at the extremely high frequencies but is also applicable to much lower ones. And while 75,000 mc./s. is a higher frequency than has yet been achieved by any other production klystron, and particularly by klystrons which put out over 40 mw. of power, even this extremely high frequency is not the upper limit. Without a basic difference in design klystrons constructed according to the invention are operable well over 150,000 mc./s., although at a somewhat reduced power output.

What is claimed is:

1. A klystron comprising an evacuated chamber including a resonant cavity as a part of said chamber, said chamber having relatively stiff walls and said resonant cavity having a pair of apertures in opposite walls thereof to allow a beam of electrons to pass therethrough; an electron gun to generate said beam of electrons and located on one side of said cavity to direct the electron beam through both of said apertures in succession; a reflector electrode located on the other side of said cavity to reflect electrons from said beam back through said apertures; a first tubular portion of the wall of said chamber; a second tubular portion extending reentrantly within said first portion; a slightly flexible diaphragm at the inner end of said reentrant portion; an elongated support member extending through the central portion of said diaphragm, said support member, diaphragm, reentrant portion, and first tubular portion all forming vacuum-tight portions of the wall of said chamber, the inner end of said support member within said chamber being attached to and supporting said electron gun; movable set screw clamping means within that part of the wall of said second tubular portion external to said evacuated chamber adjacent the outer end of said support member, a central part of said support member being sealed to said diaphragm whereby manipulation of said set screws exerts lateral pressure on said outer end of said support

member to pivot it about a point determined by said diaphragm so as to move said electron gun laterally within said chamber and align the electron beam therefrom with said apertures; a third tubular portion of said wall on the other side of said resonant cavity from said first tubular portion; a fourth tubular portion extending reentrantly within said third tubular portion; a second diaphragm closing the reentrant end of said fourth tubular portion, said second diaphragm being more flexible than said first-named diaphragm; a second elongated support member extending through the central portion of said second diaphragm; the inner end of said second support member forming said reflector electrode, said second support member, second diaphragm, fourth tubular portion and third tubular portion all forming portions of the wall of said evacuated chamber; a plurality of set screws extending through a portion of the outermost wall of said third tubular portion and exerting lateral pressure on the outer end of said second support member, said second diaphragm being sealed to said second support member at a point on said second support member intermediate the ends thereof whereby said second support member can be pivoted about a point determined by said second diaphragm by means of the lateral pressure exerted by said last-named set screws to align said reflector electrode with the electron beam passing through said apertures and means to lock all of said set screws in place once said reflector and said electron gun have been aligned.

2. A klystron comprising an evacuated chamber having a relatively stiff wall provided with axially aligned apertures, a flexible apertured diaphragm in at least one of said apertures, a pair of tubular extensions on opposite sides of said chamber surrounding said apertures and vacuum tight sealed to the wall of said chamber, at least a portion of the wall of each of said tubular extensions being relatively rigid, an electron gun assembly positioned in one of said tubular extensions, a repeller electrode positioned in the other of said tubular extensions; support members within said tubular extensions for each of said electron gun and said repeller electrode, and means external to said tubular extensions to permanently align said electron gun, said repeller electrode, and said apertures relative to one another, said means including a clamping member extending through the relatively rigid wall portion of at least one of said tubular extensions and exerting lateral pressure on at least one of said support members, and means to permanently fix the position of said clamping member.

References Cited in the file of this patent

UNITED STATES PATENTS

2,368,821	Foulkes	Feb. 6, 1945
2,396,802	Mouromtseff et al.	Mar. 19, 1946
2,416,318	Hotine	Feb. 25, 1947
2,418,317	Runge	Apr. 1, 1947
2,506,660	Blattmann et al.	May 9, 1950
2,794,931	Gardner	June 4, 1957

FOREIGN PATENTS

766,156	Great Britain	Jan. 16, 1957
---------	---------------	---------------