



INTERNATIONAL APPLICATION PUBLISHED UNDER THE PATENT COOPERATION TREATY (PCT)

<p>(51) International Patent Classification <sup>5</sup> : <b>A61F 13/15</b></p>	<p><b>A1</b></p>	<p>(11) International Publication Number: <b>WO 94/15563</b> (43) International Publication Date: 21 July 1994 (21.07.94)</p>
<p>(21) International Application Number: PCT/DK94/00008 (22) International Filing Date: 5 January 1994 (05.01.94) (30) Priority Data: 0010/93 5 January 1993 (05.01.93) DK (71)(72) Applicant and Inventor: NEUBERT, Robert [DK/DK]; Rodskovvej 51, DK-8543 Hornslet (DK). (74) Agent: K. SKØTT-JENSEN, PATENTINGENIØRER A/S; Lemmingvej 225, DK-8361 Hasselager (DK).</p>	<p>(81) Designated States: AT, AU, BB, BG, BR, BY, CA, CH, CN, CZ, CZ (Utility model), DE, DE (Utility model), DK, DK (Utility model), ES, FI, FI (Utility model), GB, HU, JP, KP, KR, KZ, LK, LU, LV, MG, MN, MW, NL, NO, NZ, PL, PT, RO, RU, SD, SE, SK, SK (Utility model), UA, US, UZ, VN, European patent (AT, BE, CH, DE, DK, ES, FR, GB, GR, IE, IT, LU, MC, NL, PT, SE), OAPI patent (BF, BJ, CF, CG, CI, CM, GA, GN, ML, MR, NE, SN, TD, TG).</p> <p><b>Published</b> <i>With international search report.</i> <i>With amended claims.</i> <i>In English translation (filed in Danish).</i></p>	

(54) Title: ABSORBING ARTICLE OF THE DIAPER OR INSERT TYPE

(57) Abstract

Hygienic, absorbing pad bodies are used increasingly as disposable units, made with a fibrous, super absorbing material in an envelope which, with the use of suitable sheet materials, is liquid tight at the outside, while at the inner side it is liquid permeable, but non-absorbing, whereby the pad in wet condition will feel dry. These articles load the refuse system due to their contents of plastics, and according to the invention it is proposed that the pad member (12) itself is made in a both mechanically and biologically decomposable manner and that the envelope (2) is designed such that after use the pad member is removable therefrom, preferably for disposal by direct closet flushing. As far as diapers are concerned the envelope (2) may be of a washable textile material, having a pocket or cover flap (10) of the non-absorbing material at the inner side, such that new pad members may be mounted in a pleasant and reusable textile diaper.

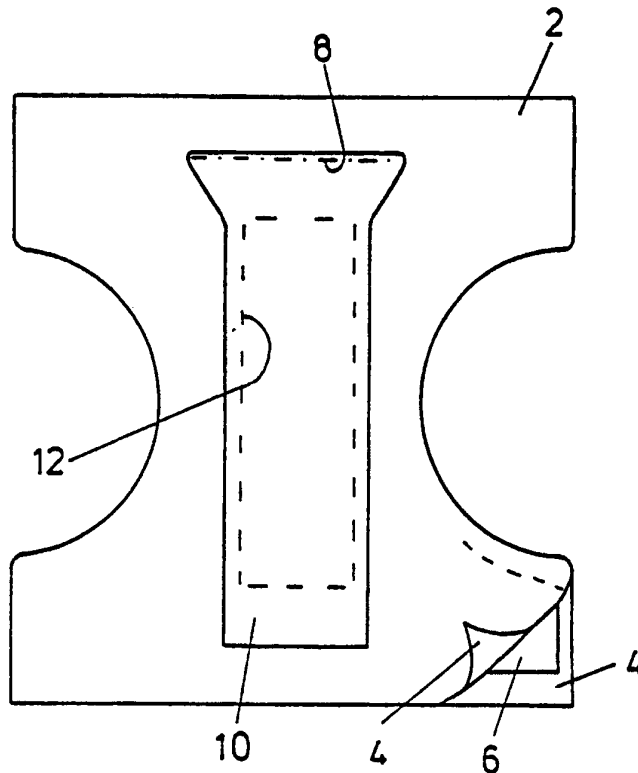

**FOR THE PURPOSES OF INFORMATION ONLY**

Codes used to identify States party to the PCT on the front pages of pamphlets publishing international applications under the PCT.

AT	Austria	GB	United Kingdom	MR	Mauritania
AU	Australia	GE	Georgia	MW	Malawi
BB	Barbados	GN	Guinea	NE	Niger
BE	Belgium	GR	Greece	NL	Netherlands
BF	Burkina Faso	HU	Hungary	NO	Norway
BG	Bulgaria	IE	Ireland	NZ	New Zealand
BJ	Benin	IT	Italy	PL	Poland
BR	Brazil	JP	Japan	PT	Portugal
BY	Belarus	KE	Kenya	RO	Romania
CA	Canada	KG	Kyrgystan	RU	Russian Federation
CF	Central African Republic	KP	Democratic People's Republic of Korea	SD	Sudan
CG	Congo	KR	Republic of Korea	SE	Sweden
CH	Switzerland	KZ	Kazakhstan	SI	Slovenia
CI	Côte d'Ivoire	LI	Liechtenstein	SK	Slovakia
CM	Cameroon	LK	Sri Lanka	SN	Senegal
CN	China	LU	Luxembourg	TD	Chad
CS	Czechoslovakia	LV	Latvia	TG	Togo
CZ	Czech Republic	MC	Monaco	TJ	Tajikistan
DE	Germany	MD	Republic of Moldova	TT	Trinidad and Tobago
DK	Denmark	MG	Madagascar	UA	Ukraine
ES	Spain	ML	Mali	US	United States of America
FI	Finland	MN	Mongolia	UZ	Uzbekistan
FR	France			VN	Viet Nam
GA	Gabon				

## ABSORBING ARTICLE OF THE DIAPER OR INSERT TYPE

The present invention relates to absorbing articles of the diaper or insert type.

Earlier it was customary to use for this type of articles simple textile pieces of cotton, which could be washed and reused many times, but for a desirably high absorption capacity it had to be accepted that several cotton layers were needed, whereby the articles became heavy and voluminous and in fact also rather expensive to wash. As well known the development has taken the direction of the use of disposable products, which have a high absorption capacity without being bulky from the beginning, because of the use of a filler material of the so-called super absorbing type.

For the actual use it is a condition that the absorption material be insulated both to the outside, so that it will not give off liquid to the surroundings, and to the inside, so it will not be in wet contact with the skin of the user. This is achieved by enveloping the material in a casing having at the outside a tight sheet layer and at the skin side a liquid permeable cover, which, itself, is of a non-absorbing plastic that will steadily be felt as a dry layer.

This holds for disposable diapers and for hygienic pads, and it is true that in the waste system these products constitute problematic units that occur in quite large amounts. They are too large to just be flushed out in the toilet, and they are not particularly suited to be delivered to the normal waste bags, e.g. for kitchen refuse; when removed as solid refuse they load the relevant destruction plants with their high contents of substances which, in fact, could be dealt with in a simpler manner, viz. by composting the purely organic substances.

The US-A-2,826,199 discloses a diaper made with an outer layer of a liquid tight material and an inner

layer of flannel rubber having small holes in its central area. From the front edge of the diaper a pocket opening extends between the two layers, and in this pocket is placed a sponge plate adapted to be reused after drying. Obviously this is no suitable solution.

In US-A-3,070,095 is disclosed a plural layer material which can be used for or as the relevant absorbing articles, having a skin touching layer of a thin, loose and soft, liquid absorbing material of cellulose which, on at least one side, is coated with a moisture tight substance, which, however, will permit a closet flushing of the article; the inner sides are impregnated with a particular absorption material, also of a decomposable character. These articles will be highly unsuitable because in order to be flushable they should exhibit such a low wet strength that they will become more or less disintegrated already when in use. Inversely, in a practically usable quality they will not be suited to be flushed out, particularly not the larger sizes, as there are not proposed any measures for facilitating the flushing.

On this background it is proposed by the present invention to design the relevant articles in such a manner that on the place of use it will be possible to effect an easy separation of the absorption material from the surrounding envelope, it being aimed hereby that the envelope material can be handled as solid refuse with a relatively small volume, while the absorption material, which accounts for the major part of the volume and is easily biologically decomposable, can be disposed of by simple closet flushing. This may be conditioned, by way of example, by the pad being separated or easily separable in two or more parts, such that these will be of a reduced size, making them suitable for this type of removal.

As far as hygienic pads are concerned the invention

may be realized in that the envelope surrounding the pad material is provided with a tearing facility that makes it possible to break the envelope for easy separation of the inner pad or the separate parts, of which it consists, such that the user can easily separate the used article in an envelope portion to be treated as kitchen refuse and one or preferably more smaller pad portions for immediate closet flushing.

As far as diapers are concerned the situation is somewhat different, because the diapers as a whole cannot be regarded as a pad or an insert, as they are complete garment articles comprising both the absorbing material pad and an associated garment portion for mounting on the body of the child. For the disposable diapers here considered it is characteristic that the garment portion is constituted by projecting extensions of the sheet materials encasing the moisture absorbing material pad, and with the invention an extra advantage will be gained when the pad material can be separated from the casing material and these materials be treated in respective optimized manners.

Particularly as far as diapers are concerned it will be especially advantageous if, on this background and in accordance with the present invention, the development is brought back to the use of washable textile materials for the envelope or garment portion. This portion may very advantageously be made of cotton or a correspondingly washable and skin friendly material, whereby the diapers will consist of a reusable casing/garment portion and a disposable absorption pad or insert.

For the refuse handling it will be of noticeable importance that a substantial part of the mass of diapers, viz, the casing or garment portions, will thus be left out from the refuse or at least only appear therein after many times of use. These textile articles should

not be dimensioned so as to be operatively absorbing, themselves, as the absorption is safeguarded by the insert pads, so they may be designed as non-voluminous articles which can be washed or co-washed in ordinary household washing machines without loading these unduly, and the result will be that the visible refuse is reduced to a minimum while the user comfort of the disposable diapers can be increased noticeably, without the removal costs being noticeably increased otherwise.

Particularly as far as diapers are concerned the refuse products will not only be liquid, but also faeces. These are beforehand well suited for delivery to the most inexpensive waste handling system, viz. by flushing to the sewer system, and here there will be no problems with respect to separation of this waste in smaller units fit to be flushed. For that sake the faeces could be delivered directly to the outside of the liquid absorbing pad portions, when these are preadapted to be flushed out.

However, for the invention it is a preferred feature that the casing or garment portion is provided with an inwardly facing pocket or flap portion of a liquid permeable and non-absorbing textile material, such that this flap portion may, in a permanent manner, form the desired dry separation between the skin and the absorbing body, i.e. without this body or pad itself having to be provided with such an outer layer. This, of course, will contribute to the low costs of the insert pads, which will not, then, need to have such a cover layer of their own. The faeces will be deposited directly on the said flap portion, but for the user it will be easy to pour or shake the faeces from the opened diaper into the closet and thereafter take or pour out the insert pad or pad portions the same way.

The pad member may be produced beforehand in a way such that it appears as a unit of sufficient size, yet

being divided in mutually coherent areas which are easily separable, e.g. already by the action of the water in the flushing system. Thereby the user may handle the pad member as a coherent, relatively large unit both when laying it into the textile garment casing and by the later removal therefrom, such that the pad will automatically be separated into smaller parts that are conveyable through the sewer system without problems.

Optionally, the said flap portion may be prepared for the holding to the textile part in being stitched thereto at one end and provided with a burr tape at the opposite, free end.

The actual diaper inserts can be made as relatively inexpensive and small members, whereby it will also be easier to produce and store them in different designs, e.g. in particularly adapted designs for girls and boys and in different sizes and different absorption capacities. It is important here that the diurnal rhythm of the children enable a differentiated application of pads with different absorption capacities, because at several of the changings it is then possible to use cheaper pads with reduced capacity relative to the high night capacity normally aimed at. It is to be noticed that every unused capacity, e.g. during the day hours, will mean a certain mass of refuse loading any removal system in an unnecessary way, while also the same mass or amount has had to be produced, mostly as wood pulp. In connection with the invention, of course, the same size of diaper casing can be used with pad inserts of different capacities.

In a preferred embodiment of the invention the said flap portion is made with such an oversize that it can be used for a real packing in of the pad member, which, by the associated stabilization, may be produced in a low-coherent quality promoting the flushability, and the absorbing insert may be a bunch or a paper wrapped

pack of fully loose, unbounded fibres.

In the following the invention is described in more detail with reference to the drawing, in which:-

Fig. 1 is a plan view of a diaper member according to the invention;

Fig. 2 is a corresponding view of a diaper insert;

Fig. 3 is a perspective view of a hygienic pad;

Fig. 4 is a plan view of a preferred embodiment of a diaper garment according to the invention;

Fig. 5 is a perspective view of a preferred embodiment of a diaper according to the invention;

Fig. 6 is a sectional view thereof;

Figs. 7 and 8 are sectional view of a pad insert therefor, and

Figs. 9 and 10 are a perspective view and an end view, respectively, of an insert according to the invention.

The diaper shown in Fig. 1 comprises an outer cover or garment portion 2 made of cotton or a corresponding textile material. This material does not, itself, constitute the relevant absorbent of the diaper, and the cover 2, therefore, can be made as a lightweight product, preferably consisting of two textile layers 4 with an intermediate layer 6 of a liquid tight material, this layer being somewhat retracted from the edge of the cover. In order for the cover to be easy to wash and dry, instead of pure cotton it may consist of a mixture, e.g. 60 % cotton and 40 % polyester, which will also improve the lifetime of the product. The contents of artificial fibres may even be still higher, since there is no need for any absorbing capacity, and the modern artificial materials can be made so that they are very soft and comfortable. In a manner not shown the cover can be provided with special closing facilities, e.g. burr tapes, just as it may otherwise be prepared with a high quality, e.g. with incorporated rubber bands at the



edges of the side constrictions; it will be acceptable that the product is considerably more expensive than a disposable diaper, as it may be used hundreds of times and moreover be more comfortable every time.

At the tight places around the legs and the waist the cover will provide a pleasant, breathing textile contact, because the layer 6 is retracted from the edge of the cover, while this layer will otherwise prevent access of liquid to the textile layer facing the skin. It should be mentioned that it is not even necessary for the layer 6 to be located spaced from the edge, as the skin will be touched by a breathing textile layer anyway. The edge area of the layer 6 may then be effectively prevented from touching the skin by making the edge seam on an outwardly folded edge fold of the workpiece.

At the interior side of the cover 2 there is secured by stitching, at 8, a textile flap 10 of a liquid permeable, non-absorbing material, e.g. of the type known from the inner side of disposable diapers, but optionally of a still better quality. This flap covers the entire critical area and is adapted to cover a diaper pad 12 that is laid under the flap. Optionally, the free end of the flap may be adapted to be fastened releasably to the cover 2, e.g. by means of burr locking.

The diaper pads, as mentioned, may be manufactured in different models, partly for girls and boys, respectively, partly with different sizes, and partly with different absorbing capacities. The pads or inserts may be made from fibre mass without any kind of envelope, optionally only with an increased concentration of binding fibres on the flat sides, and with an adjusted content of a super absorbing substance. The pads may be closed at the edges by welding or any other manner. At their outsides they may carry a couple of strips of adhesive that will stabilize them in their mounted condition.

It will be possible to adapt the pads to the waste or decomposition system to which the used pads are delivered, for example combustion, direct composting or composting from the sewer system, after closet flushing in the latter case. The larger pads may be unfit for direct flushing, but according to the invention they may be subdivided in two or more pieces that are easy to separate in connection with their removal from the cover, e.g. in connection with a joining area already being weakened in the wet surroundings prior to that removal. The flushing will be an attractive possibility, and since the user will normally be conscious of the fact that whole pads may choke the downlet, the user will then be motivated to carry out a modest activity for effecting the required separation, when the pads are suitably prepared. They may consist of mutually separated pad portions joined only by an adhesive tape to form the entire pad, and the user should then only tear up a portion of this tape for separating the pad. Fig. 2 shows a diaper pad 12 with an indicated separation area 14.

Fig. 3 shows a hygienic pad comprising a corresponding absorbing pad 12 surrounded by a casing having a liquid tight outer layer and a non-absorbing, liquid permeable inner layer. According to the invention this casing is provided with a tear up cord 16 enabling the user to open the casing in a simple manner for dropping the used pad in the closet and subsequent handling of the casing as solid waste. Alternatively, one side may be in two pieces, joined by a removable adhering tape.

It is a further possibility that also ordinary disposable diapers may be designed according to the principle here disclosed, i.e. with a removable insert pad for removal by flushing, while it will then only be the remaining part of the diaper that loads the household refuse generally.

Fig. 4 shows a diaper garment or cover corresponding to Fig. 1, where only now the flap 10 is stitched or otherwise secured to the main portion along three sides, such that an elongate pocket is formed, accessible from the rear end of the diaper for introduction of a hand and therewith also for both insertion and removal of a diaper pad 12. Thus, this pad will be totally supported inside the pocket, whereby the demand for rigidity of the pads can be reduced. At the extreme, a handful of loose fibres could be sufficient, taken from a mixture of cellulose fibres and fibres of a super absorbing material, but preferably, prefabricated fibre packages should be used, only with a wrapping of paper like toilet paper, such that the pads, after use, are well suited to be flushed out in the closet after being withdrawn or otherwise manipulated out from the elongate pocket once faeces, if any, are sent the same way.

When the requirements as to the rigidity of the pads are kept low, these pads will be particularly easy to produce in a manner promoting their ability to be removed by flushing into the sewer system. The pads will not have to be wrapped in any particularly strong material, and optionally they may just be surface coated by spraying with a suitable binding agent, which becomes partly decomposed already during its stay in the diaper pocket, once this has been wetted during the use.

After use, the pad will be easy to press or pour out of the diaper pocket, and it is easily beaten apart by the very flushing. If desired, the pad may also be disposed of as a fully compostible solid waste, a so-called green waste product.

Preferably, the length of the pads used is only slightly more than half the length of the pocket. The pad may then be placed correctly all according to the wearer being a girl or a boy, and moreover, for particularly productive periods such as overnight, two partly

overlapping pads may be placed in the pocket, such that a desirable differentiation is achievable with the use of cheap standard components. It is also a possibility that the pads can be still smaller, both in area and thickness, whereby the use can be differentiated still more.

As an alternative to the flap 10 of Fig. 1 and the pocket according to Fig. 4, more flaps or half pockets of the liquid permeable material can be used, e.g. a side flap fixed to one of the long sides, Fig. 4, and a half pocket fixed to the other long side and to the shorter front side, whereby the inserted pad or pads may be easier to remove, even though they will still be well stabilized in use. Even traditional disposable diapers may, advantageously, be arranged in this or a similar manner for enabling a refuse separation between the contents and the cover.

A preferred embodiment of the diaper cover is shown in Fig. 5. The textile diaper of Fig. 1 is here supplemented with a stitched on textile strip 20, which in a known manner may form an extrusion barrier towards the sides and rearwardly from the central production area. This strip may consist of the same impermeable, yet breathing material as the intermediate layer 6 in the cover. To one of the sides of this strip there is secured a laterally projecting flap portion 22 consisting of the said permeable and non-absorbing material of the flap 10 in Fig. 1. As shown, this flap portion may have bent over side edge portions 24, between which, at the outer end of the flap portion, there may be placed an absorbing pad 12, whereafter the flap portion may be folded a couple of times until the pad is brought into a position in the receiver trough formed by the space inside the strip 20, confer Fig. 6.

Hereby the pad insert 12 will be easy to mount, but in particular the pad will be effectively enclosed in

the flap portion 22 and will be easy to pour out from its mounted position, viz. by a simple lateral tilting of the cover, whereby the pad, all by itself, will roll out from its mounted position, preferably for delivery to the closet for being flushed out.

Because the pad 12 will here be particularly well protected inside the folded together flap portion 22 as held inside the pocket 20, the pad may be designed in a correspondingly weakened manner, such that it may be particularly easily disintegratable when poured into the closet.

Preferably, confer Fig. 7, the pad insert 12 is produced as a plate 26 of a fibrous, absorbing material surrounded by a wrapping 28 of a paper of low wet strength, i.e. of the toilet paper type, which may be wrapped one or more times about the fibre plate 26. In Fig. 7 the paper is shown wrapped one and a half time, whereby there will be double layer strength at one side, while at the side edges there is only a single layer of paper. When the fibre plate 26 expands by liquid absorption these side edge areas will be stretched by the associated thickening of the plate, whereby the paper will burst such that the wrapping will not thereafter hold the fibre plate package 26 together. The pad insert may thus be poured out in an already partly disintegrated condition, whereby, by the flushing itself, it is readily further disintegrated.

As already mentioned in connection with Fig. 3, the pad may be provided with a tear cord 16, which, however, will now refer to a tearing of the paper casing around the fibre package 26 for ensuring an easy flushability of the entire pad insert 12. It is to be noted that faeces, if any, will have been delivered to the closet already before it becomes actual to handle the pad insert, whereby it will be a clean and simple operation to break up the pad for ensuring a safe flushing thereof.

It will even be a further possibility to create, in connection with the mounting of the pad, an operative connection with the diaper or the flap 22, e.g. with the use of an adhering zone, such that already by the very pouring out of the pad the pad will get torn without any separate manipulation.

In Fig.8 it is shown that instead of a single fibre plate 26 two mutually separated plates or pads 30 may be used. In principle, such a division may occur in both the longitudinal and the transverse direction, whereby it is preensured that the pads are divided into relatively small pieces that are flushable without problems. This may cause difficulties in the production, but already a simple two part division of the fibre plate in the longitudinal or the transverse direction will provide a good result.

Fig. 9 shows that the pad 12 may appear as a suitably closed package, with the paper wrapping 28 closed by a stamping 32 at the ends. Thus, such a pad may as a whole be flushed out in the closet after use, in a more or less disintegrated condition.

In connection with the invention it has been realized that with the use of simple fibre packages 26,30 with an even material distribution, including that of the superabsorbing material, it will be advantageous to make arrangements for facilitating the distribution of spotwise applied liquid over the whole area of the pad, such that the absorption capacity may be fully exploited. For that reason, Figs. 9 and 10 show that the pad 12 may be designed with stamped surface grooves 34, along which the liquid may be distributed all over the pad area.

It should be mentioned that for a further optimizing in this respect paper wrappings may be used, the fibre direction of which will predominantly promote a liquid spreading in the longitudinal direction of the

pad. Moreover, it is possible to choose for the flap 22 a fabric with good liquid spreading abilities.

Even though the pad, when removed, has not been fully utilized, it will have been wetted at least over a partial area, sufficiently to weaken the paper wrapping in order to be easily broken. Most users will automatically make sure that the used pad is at least partially broken before delivering it to the closet, and as the flap fabric 22 will typically be a deformable knitted product the user may easily and as a matter of routine effect a breaking of the pad by external manipulation of the wrapping 22 or for that sake the entire relevant area of the diaper. Therefore, special means for breaking up the pads could well be renounced.

## C L A I M S :

1. An absorbing article of the diaper or insert type, comprising a fibrous pad body in a wrapping that is liquid impermeable at one pad side and liquid permeable at the opposite side, the body side, characterized in that the pad body is a separate element, which is made so as to be biologically decomposable, e.g. with an envelope wrapping of pure paper, and that the said wrapping is designed so as to be easily openable for enabling removal of the pad therefrom after use, the pad body preferably being designed so as to be flushable in the closet.

2. An article according to claim 1, characterized in that the wrapping is made as a reusable, washable diaper garment mainly consisting of cotton or a similar textile material in two layers with an intermediate, moisture impermeable sheet layer, the garment having at its body side a pocket or flap formation of a material of a non-absorbing, but liquid permeable type, behind which one or more pad bodies are removably mountable in a stabilized position of use.

3. An article according to claim 2, characterized in that the flap formation projects in the cross direction of the diaper garment and has a length substantially larger than the width of the pad inserts.

4. An article according to claim 2, characterized in that the pocket or flap formation is mounted in such a manner that the pad inserts are naturally placeable inside an area delimited by a barrier strip at the inside of the diaper garment.

5. An article according to claim 2, characterized in that the flap formation is made with folded side edge portions.

6. An insert for an article according to claim 1,



characterized in that it is made as an absorption pad adapted for use once only and preferably made in such a disintegratable manner that it is flushable in the closet.

7. An insert according to claim 6, characterized in that it is generally made with a low wet strength, either as a whole or/and in areas of separation between partial areas thereof.

8. An insert according to claim 7, characterized in that it appears as a fibre package in a wrapping of paper of toilet paper quality.

9. An insert according to claim 6, characterized in that it is made with means for tearing up the insert.

10. An insert according to claim 6, characterized in that it is made with an adhering area for adhesion to the diaper garment.

11. An insert according to claim 6, characterized in that it is made with exterior longitudinal grooves and, optionally, with other measures for the spreading of locally received liquid.

12. An article according to claim 1 and an associated insert according to claim 6, characterized in that between the article and the insert there is arranged an engagement to the effect that the insert, when removed or poured out, will automatically be disintegrated at least partially.

## AMENDED CLAIMS

[received by the International Bureau on 6 June 1994 (06.06.94);  
original claims 1-12 replaced by amended claims 1-11 (2 pages)]

1. A garment article of the diaper type for use in combination with an absorbing fibrous pad body enclosed so as to be accessible for liquid from one side, through a permeable non-absorbing cover sheet, while at the opposite side the pad body is covered by a liquid impermeable material, characterized in that the diaper garment article is a washable and reusable textile unit comprising, generally at least two textile layers and an intermediate liquid impermeable barrier layer, the skin contact side of the article being provided with an openable and closable pocket or flap formation constituting said permeable, non-absorbing cover sheet and adapted to receive one or more absorbing pads of a flushable type.

2. An article according to claim 1, in which the flap formation is a sheet member secured to the garment along one side or end only, so as to be usable as a wrapping for the absorbing pad or pads.

3. An article according to claim 2, in which the flap sheet member is attached to the garment along a longitudinal seam so as to project therefrom generally in the width direction of the garment.

4. An article according to claim 2, in which the pocket or flap formation is mounted in such a manner that the pad or pads are naturally placeable inside an area delimited by a freely outstanding barrier edge strip on the inside of the diaper garment.

5. An article according to claim 2, in which the flap formation is made with folded side edge portions to accommodate opposed pad edge areas.

6. As a commercially available, disposable refill for mounting in reusable, purpose adapted holding garment articles, preferably as claimed in claim 1, an absorbing pad member having a body of absorption material and an outer wrapping or coating of an easily breakable material, e.g. of toilet paper type, so as to be disposable by flushing.

7. A refill pad member according to claim 6 and made with a low wet strength, either as a whole or/and in areas of separation between partial areas thereof.

8. A refill pad member according to claim 6, made with means for tearing up the pad.

9. A refill pad according to claim 6 and made with an adhering area for adhesion to the holding garment.

10. A refill pad according to claim 6, made with exterior longitudinal grooves and, optionally, with other measures for the spreading of locally received liquid.

11. An article according to claim 1 and an associated refill pad member according to claim 6, characterized in that one or both of these elements are prepared such that between them there is arranged an engagement to the effect that the refill pad, when removed or poured out, will automatically be disintegrated at least partially.

1/2

FIG. 1

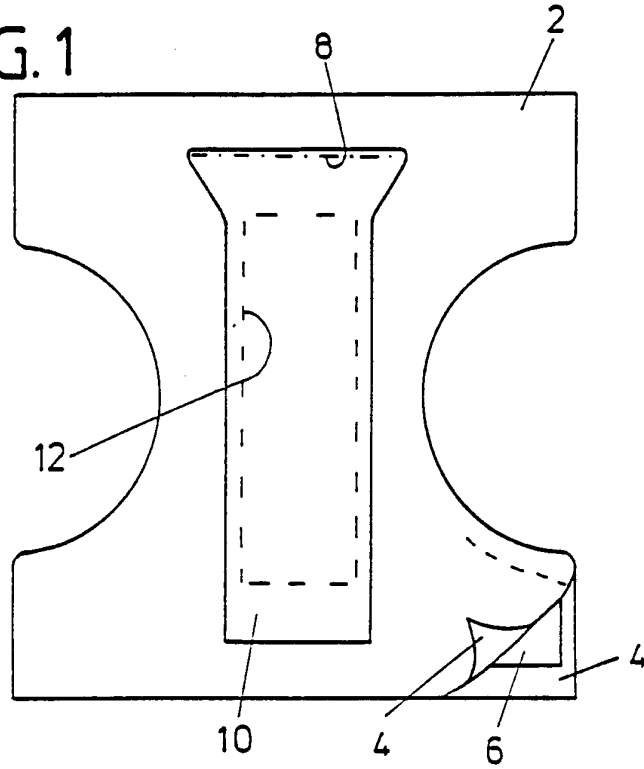

FIG. 2

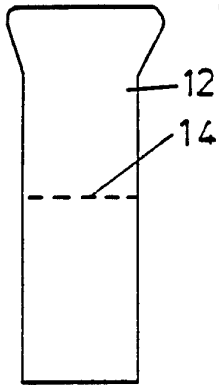

FIG. 3

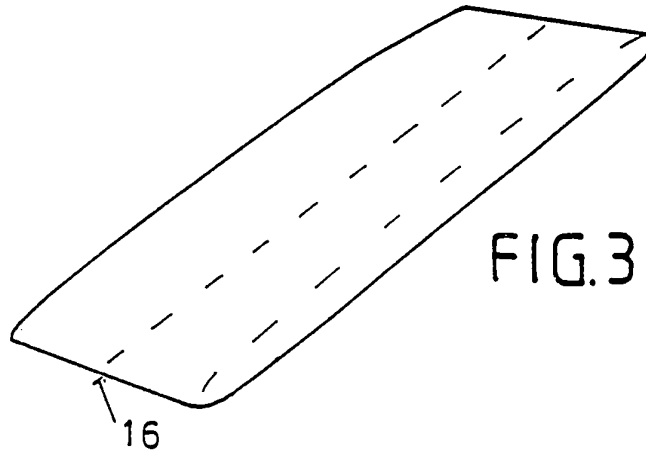
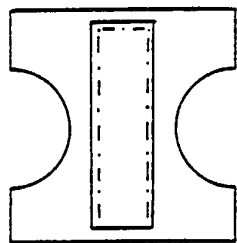
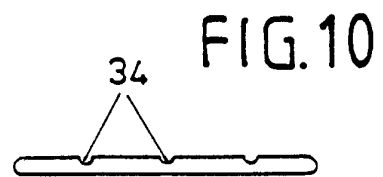
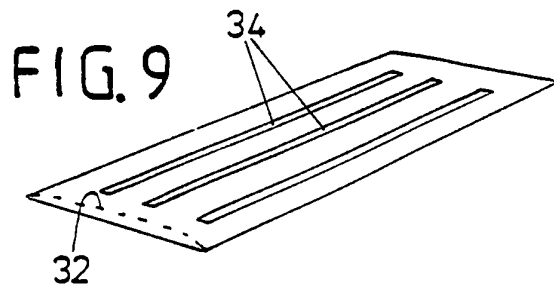
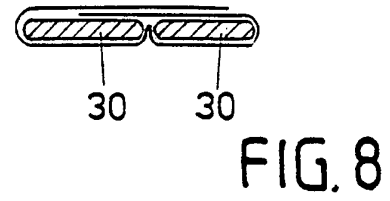
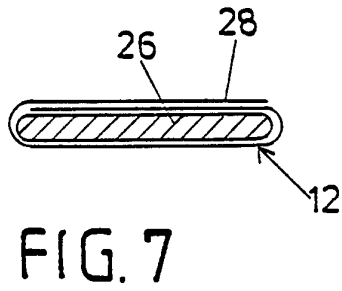
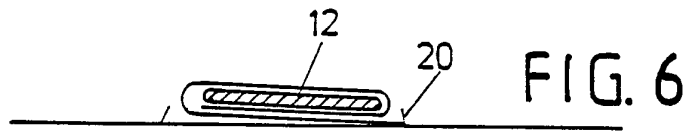
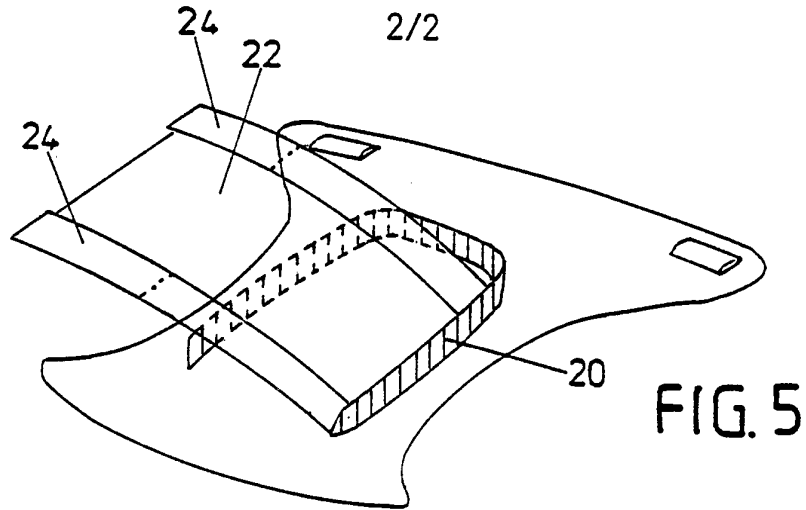

FIG. 4





## INTERNATIONAL SEARCH REPORT

International application No.

PCT/DK 94/00008

A. CLASSIFICATION OF SUBJECT MATTER		
IPC5: A61F 13/15 According to International Patent Classification (IPC) or to both national classification and IPC		
B. FIELDS SEARCHED		
Minimum documentation searched (classification system followed by classification symbols)		
IPC5: A61F		
Documentation searched other than minimum documentation to the extent that such documents are included in the fields searched		
SE,DK,FI,NO classes as above		
Electronic data base consulted during the international search (name of data base and, where practicable, search terms used)		
C. DOCUMENTS CONSIDERED TO BE RELEVANT		
Category*	Citation of document, with indication, where appropriate, of the relevant passages	Relevant to claim No.
X	US, A, 5026363 (PRATT), 25 June 1991 (25.06.91)	1,5-10,12
Y	--	2-4,11
X	US, A, 4964857 (OSBORN), 23 October 1990 (23.10.90)	1,6
Y	US, A, 4352356 (TONG), 5 October 1982 (05.10.82), figures 1,2	2-4
Y	US, A, 4022210 (GLASSMAN), 10 May 1977 (10.05.77), figures 3,5	11
<input checked="" type="checkbox"/> Further documents are listed in the continuation of Box C. <input checked="" type="checkbox"/> See patent family annex.		
* Special categories of cited documents: "A" document defining the general state of the art which is not considered to be of particular relevance "B" earlier document but published on or after the international filing date "L" document which may throw doubts on priority claim(s) or which is cited to establish the publication date of another citation or other special reason (as specified) "O" document referring to an oral disclosure, use, exhibition or other means "P" document published prior to the international filing date but later than the priority date claimed "T" later document published after the international filing date or priority date and not in conflict with the application but cited to understand the principle or theory underlying the invention "X" document of particular relevance: the claimed invention cannot be considered novel or cannot be considered to involve an inventive step when the document is taken alone "Y" document of particular relevance: the claimed invention cannot be considered to involve an inventive step when the document is combined with one or more other such documents, such combination being obvious to a person skilled in the art "&" document member of the same patent family		
Date of the actual completion of the international search		Date of mailing of the international search report
8 April 1994		14 -04- 1994
Name and mailing address of the ISA/ Swedish Patent Office Box 5055, S-102 42 STOCKHOLM Facsimile No. +46 8 666 02 86		Authorized officer  Ingrid Falk Telephone No. +46 8 782 25 00

## INTERNATIONAL SEARCH REPORT

International application No.

PCT/DK 94/00008

C (Continuation). DOCUMENTS CONSIDERED TO BE RELEVANT		
Category*	Citation of document, with indication, where appropriate, of the relevant passages	Relevant to claim No.
P	EP, A1, 0549988 (KIMBERLY-CLARK CORPORATION), 7 July 1993 (07.07.93)  -----  -----	1-12

**INTERNATIONAL SEARCH REPORT**  
 Information on patent family members

26/02/94

International application No.  
 PCT/DK 94/00008

Patent document cited in search report	Publication date	Patent family member(s)	Publication date
US-A- 5026363	25/06/91	NONE	
US-A- 4964857	23/10/90	NONE	
US-A- 4352356	05/10/82	GB-A,B- 2070086 GB-A,B- 2124072	03/09/81 15/02/84
US-A- 4022210	10/05/77	NONE	
EP-A1- 0549988	07/07/93	AU-A- 3046192 CA-A- 2072689	08/07/93 01/07/93