

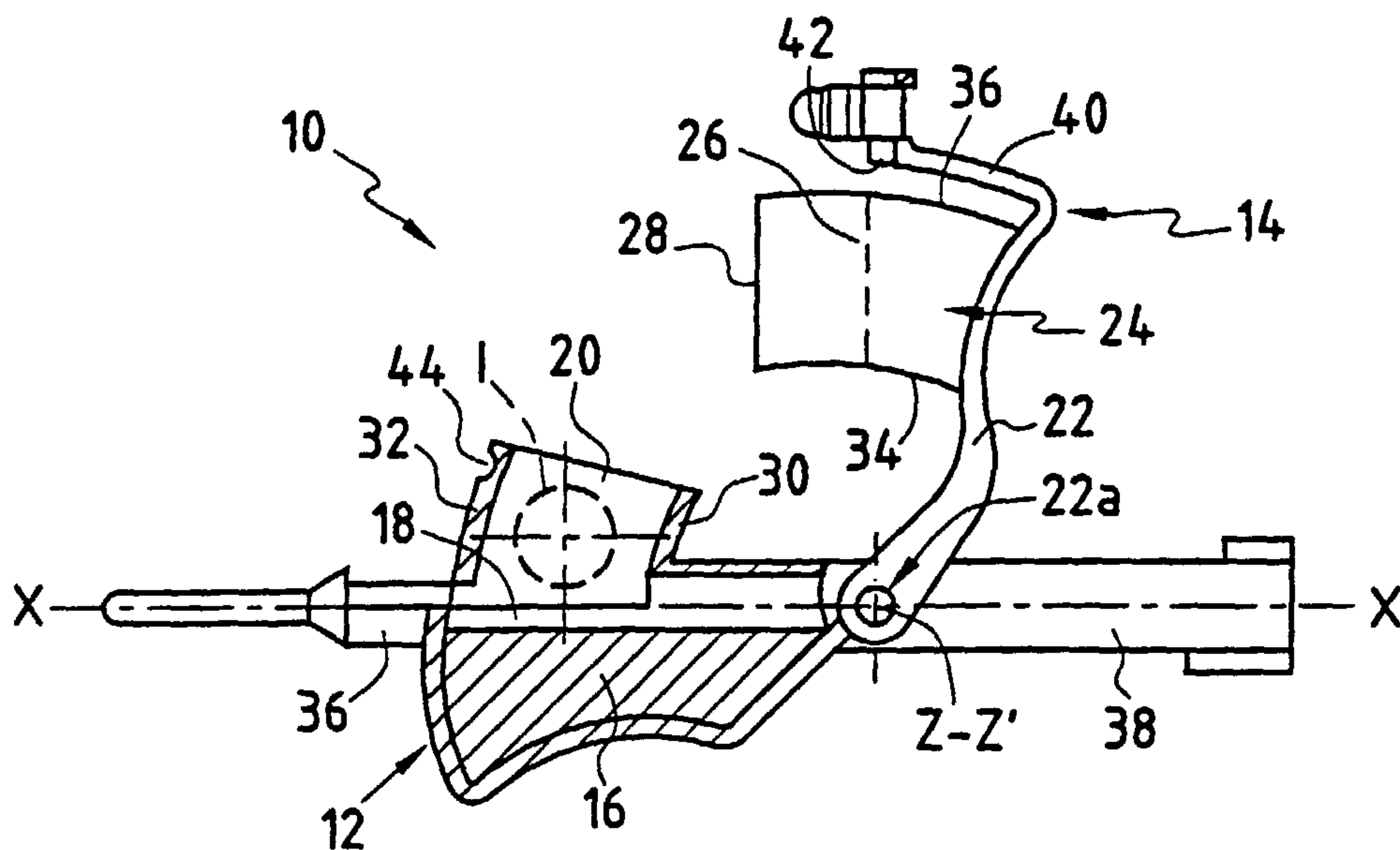

(86) Date de dépôt PCT/PCT Filing Date: 2001/05/17
 (87) Date publication PCT/PCT Publication Date: 2001/11/22
 (85) Entrée phase nationale/National Entry: 2002/11/18
 (86) N° demande PCT/PCT Application No.: FR 2001/001510
 (87) N° publication PCT/PCT Publication No.: 2001/087186
 (30) Priorité/Priority: 2000/05/19 (00/06417) FR

(51) Cl.Int.⁷/Int.Cl.⁷ A61F 2/16, A61B 17/28
 (71) Demandeur/Applicant:
CORNEAL INDUSTRIE, FR
 (72) Inventeurs/Inventors:
JEANNIN, LIONEL, FR;
BOS, GILLES, FR
 (74) Agent: SIM & MCBURNEY

(54) Titre : INJECTEUR POUR IMPLANT SOUPLE
 (54) Title: INJECTOR FOR FLEXIBLE IMPLANT



(57) **Abrégé/Abstract:**

The invention concerns a module for folding a flexible intraocular implant for its injection into a patient's eye. The module comprises two jaws (12, 14) mobile relative to each other, each jaw comprising a folding wall (18, 26) formed by a cylindrical surface portion and a planar wall (20, 28) integral with the folding wall, the two planar walls being arranged in parallel planes; a rotation shaft (22) orthogonal to the planar walls to control the relative rotational movement of a jaw relative to the other; one of the jaws being capable of taking up with respect to the other a first position wherein the planar walls are offset relative to each other; a second position wherein the planar walls are opposite each other to define a confinement volume for the implant; a third position wherein the folding walls are mutually linked to define a folding chamber ensuring the final folding of the implant.

A B S T R A C T

AN INJECTOR FOR A FLEXIBLE IMPLANT

5 The invention relates to a folder module for folding
a flexible intraocular implant for injection into the eye
of a patient. The module comprises two jaws (12, 14)
that are movable relative to each other, each jaw having
a folder wall (18, 26) constituted by a portion of a
10 cylindrical surface, and a plane wall (20, 28) secured to
the folder wall, the two plane walls lying in parallel
planes;

- a pivot axis (22) orthogonal to the plane walls to
control relative pivoting movement of one jaw relative to
15 the other;

- one of the jaws being capable of occupying
relative to the other a first position in which said
plane walls are offset relative to each other;

- a second position in which the plane walls face
20 each other so as to define an implant confinement volume;
and

- a third position in which the folder walls meet
each other to define a folder chamber enabling the
implant to be finally folded.

25

30

Translation of the title and the abstract as they were when originally filed by the
Applicant. No account has been taken of any changes that may have been made
35 subsequently by the PCT Authorities acting ex officio, e.g. under PCT Rules 37.2,
38.2, and/or 48.3.

AN INJECTOR FOR A FLEXIBLE IMPLANT

The present invention relates to a folder module for folding a flexible implant and to a flexible implant injector using the folder module.

5 Flexible implants are usually made of polyhydroxyethyl methacrylate (pHEMA) or of a silicone-based material presenting the essential feature that since the optical portion of such an implant is made out of such a flexible material, the implant and in
10 particular its optical portion can be folded so as to reduce its transverse dimensions and thus enable the implant to be inserted into the eye through an incision made in the cornea, said incision being very small in size, typically about 3 millimeters (mm).

15 Such flexible implants are particularly advantageous in that novel techniques for removing the natural lens now require an incision to be made in the lens that is of small size only, about 3 mm when using the technique of phacoemulsification.

20 Nevertheless, folding the implant which is constituted by a substantially circular optical portion and by a haptic portion, presents certain difficulties, in particular because of the small dimensions of an intraocular implant where the diameter of the optical
25 portion is typically no more than 6 mm, given the nature of the material constituting the implant.

In order to enable the implant to be folded or rolled up prior to being inserted in the eye, various types of flexible implant injector have already been
30 proposed that incorporate a folder unit for the implant.

The term "folding" the implant should be understood as covering any mechanical operation enabling the shape of the implant to be modified elastically, and in particular the shape of its optical portion, so as to
35 reduce the transverse size of the implant, i.e. in a direction that is orthogonal to the diameter of the optical portion containing the haptic elements of the

implant. This can comprise merely folding about a diameter of the optical portion, or folding that is more complex about axes that are parallel to said diameter, or indeed rolling up about an axis parallel to said
5 diameter.

It will be understood that once the implant has been folded, it suffices to place a cannula in the incision in the eye, said cannula extending the folder unit, and then to push the implant while it is in its folded shape
10 through the cannula and into the inside of the eye.

Document WO 95/13022 describes a flexible implant injector comprising a folder unit which is constituted firstly by a folder chamber having a curved folder wall and two parallel walls, and secondly by a pusher acting
15 on the proximal edge of the optical portion of the implant in a direction orthogonal to the folder wall, so that progressive displacement of the pusher causes the implant to be folded or rolled up.

Nevertheless, it has been found that that type unit
20 for folding or rolling up an implant is poorly adapted, particularly when the implant has certain types of haptic portion. It will be understood that the haptic portion which is usually constituted by two distinct elements needs to be folded or rolled up in the same direction as
25 the optical portion. Unfortunately, the haptic portion is of dimensions that are small relative to those of the optical portion and as a result it has weaker mechanical strength properties which make folding the haptic portion very difficult.

30 In addition, it is awkward to put the implant into the folder chamber of a known folder module, and proper positioning of the haptic portions is random.

An object of the present invention is to provide a flexible implant folder module and a flexible implant
35 injector using said folder module that make it possible to ensure that not only the optical portion but also the

haptic portion of the intraocular implant can be folded or rolled up under improved conditions.

According to the invention, this object is achieved by a flexible implant folder module comprising:

5 - two jaws that are movable relative to each other, each jaw having a folder wall constituted by a portion of a cylindrical surface and a plane wall secured to the folder wall, the two plane walls lying in parallel planes;

10 - a pivot axis orthogonal to the plane walls to control relative pivoting movement of one jaw relative to the other;

 - one of the jaws being capable of occupying relative to the other jaw a first position in which the
15 plane walls are spaced apart from each other, thereby enabling the implant to be put into place on the bottom plane wall;

 - a second position in which the plane walls face each other, whereby the folder walls and the plane walls
20 define a confinement volume for the implant; and

 - a third position in which the folder walls meet each other so as to define a substantially cylindrical volume forming a folder chamber enabling the implant to be finally folded.

25 Because of the relative pivoting movement of the two jaws about the pivot axis, the folder walls of the jaws do not make contact simultaneously with both elements of the haptic portion of the implant and with its optical
30 action on the various portions of the implant in this manner that is offset in time makes it possible to obtain appropriate folding of the implant as a whole, regardless of the shape of the elements constituting the haptic
portion.

35 In addition, the implant is easy to put into place in the module when the two jaws are in their first relative position.

Preferably, the first of said jaws further comprises two side walls parallel to said pivot axis and secured to the edges of the plane wall of said jaw, such that when the two jaws are in their second relative position, the plane walls, the folder walls, and the side walls together define a "closed" storage space in which the implant can be held in a non-folded state.

By means of this disposition, the implant can be placed initially in the storage chamber, with the module then serving simultaneously as an element for confining the implant. The surgeon then need only remove the packaging from the module already fitted with its implant and bring the two jaws into their third relative position in order to be able to proceed with injecting the implant into the eye of a patient.

The invention also provides a flexible implant injector which is characterized in that it comprises:

- a folder module;
- an injector body including a housing for receiving said folder module, an injection cannula for extending said injection passage when said folder module is in place in said housing, and an axial guide duct for extending said guide passage when said folder module is in place in said housing; and
- a piston whose rod is slidably mounted in said axial guide duct, whereby the end of the rod of said piston can co-operate with one end of the pusher member of said folder module.

In a first embodiment of the injector, the folder module is removable from the injector body so that after the injector has been used it suffices to change the folder module in which the implant was initially stored. In a second embodiment, the folder module forms an integral portion of the injector and the entire injector needs to be changed on each use.

Other characteristics and advantages of the invention appear more clearly on reading the following

description of various embodiments of the invention given as non-limiting examples.

The description refers to the accompanying figures, in which:

- 5 - Figure 1 is a fragmentary section view of a folder module in the open position;
- Figure 2A is a longitudinal section view of the module in an intermediate open position;
- Figure 2B is a section view on line B-B of
10 Figure 2A;
- Figure 3A is a longitudinal section view of the module in a final folding position;
- Figure 3B is a section view on line B-B of
Figure 3A;
- 15 - Figure 4 is a plan view of an implant injector of the invention;
- Figure 5 is a longitudinal section view of the Figure 4 injector;
- Figure 6 is a side view of the Figure 4 implant
20 injector; and
- Figures 7A and 7B are diagrams showing how the implant is folded in a standard injector and in an injector in accordance with the invention.

With reference initially to Figures 1 to 3, there
25 follows a description of a preferred embodiment of the module for folding a flexible implant. The module 10 is essentially constituted by a first jaw 12 and by a second jaw 14 which are mutually pivotable about an axis. The first jaw 12 has a base 16 which defines a folder face 18
30 of semicylindrical shape on an axis X-X' together with an extension defining a plane face 20 which is connected tangentially to the folder face 18. The base 16 serves to connect the pivot axis Z-Z' which is orthogonal to the longitudinal axis X-X' to the folder face 18 and to the
35 plane face 20. The second jaw 14 also comprises a base 22 which is in the form of an arm having one end 22a mounted to pivot about the axis Z-Z' and an extension 24

defining a folder face 26 that is substantially semicylindrical in shape, together with a plane face 28. These various portions can be seen more clearly in Figure 2B. The first jaw 12 also has two ribs 30 and 32 disposed on either side of the plane face 20. These ribs 30 and 32 are in the form of circular arcs centered on the axis Z-Z'. In the same manner, the base 24 and the extension 26, 28 of the second jaw 14 have edges 34 and 36 in the form of circular arcs. The first jaw 12 also has a first injection passage 36 disposed on the axis X-X' and enabling the implant to be expelled after it has been folded, and a second guide passage 38 which enables a pusher member to slide so as to enable the folded implant to be introduced into the injection passage 36.

As shown better in Figure 2B, the plane faces 20 and 28 of the two jaws are spaced apart by a distance h which is greater than the thickness of the implant to be folded and which corresponds to the outside diameter of the implant after it has been folded. The distance h corresponds to the inside diameter of the injection passage 36. h preferably lies in the range 1 mm to 3 mm. As also shown in Figure 2B, the face 24a of the base 24 can slide over the plane face 20 of the other jaw, and the same applies to the face 16a of the base 16 and the plane face 28 of the other jaw.

In addition, the jaw pivot axis Z-Z' preferably intersects the axis X-X' of the jaw 12.

In Figure 1, the second jaw 14 is shown in its position where it is spaced fully apart from the first jaw 12. In this position, it is easy to put an implant I into place so that it rests on the plane face 20 between the two side walls 30 and 32.

The jaw 14 can then be moved into a second position as shown in Figure 2A in which the jaw 14 is partially engaged with the jaw 12. More precisely, the arm 22 of the jaw 14 has an extension 40 provided with a pip 42 which can co-operate with the notch 44 provided in the

outside face of the side wall 32 of the jaw 12. The jaw 12 can thus be prevented from pivoting relative to the jaw 14 in a position such that the volume V1 defined by the folder faces 26 and 18 and by the plane faces 20 and 28, and by the side walls contain the implant I but without folding it. This position of the two jaws constitutes an implant-confinement position optionally allowing it to be stored for a reasonable length of time.

Furthermore, it should be observed that in this stage, and in the following stage (Figures 3A and 3B), the plane face of one jaw meets the semicylindrical face of the other jaw substantially tangentially. This avoids having any point of singularity when the two jaws are brought together.

The implant can be folded in the manner defined above by bringing the jaw 14 into a third position relative to the jaw 12 in which the two semicylindrical folder faces are adjacent so as to define an internal volume V2 of substantially cylindrical shape. On passing from the position shown in Figure 2B to the position shown in Figure 3B, it will be understood that the coming together of the folder faces of the two jaws causes the implant to be folded, with the implant being held between the plane faces 20 and 28. Depending on the nature and the dimensions of the implant, this folding can be folding substantially along a diameter of the optical portion of the implant, or folding that is more complex, or indeed it can comprise rolling the implant up about an axis parallel to the axis X-X'. The end of the extension 40 may have a snap-fastening system 46 co-operating with the outside face of the injection channel 36 to hold the jaw 14 in the position shown in Figure 3A, i.e. in the injection position.

The folder module shown in Figures 1 to 3 is designed to be put into place in an injector body for actual injection of the implant. Under such circumstances, the guide channel 38 is fitted with a

pusher 50 enabling the folded implant to be introduced into the guide channel 36 under drive from a piston fitted to the injector body.

Figure 7A shows an implant I being folded by a conventional type of folder module in which there is a folder chamber 60 defining a folder wall of semicylindrical shape 62 and two parallel walls, of which only the wall 64 is visible. Folding is obtained by movement in rectilinear translation along a direction orthogonal to the folder wall 62 of a pusher 66 whose active face 68 is likewise semicylindrical. During displacement of the pusher 66 in rectilinear translation, its folder face 68 acts simultaneously on the proximal edges 70 and 71 of the implant I, i.e. on its haptic portions 74 and 76. These proximal edges 70 and 71 are mechanically independent of each other. When the active face 68 of the pusher 66 comes into contact with one of the proximal edges, the folding or rolling up of the corresponding portion of the implant can take place randomly in one direction or the other. Since the two proximal edges 70 and 71 are mechanically independent, there is a risk that the direction in which folding or rolling up begins will be different for these two haptic portions 74 and 76. Having the two haptic portions folded in different directions runs the risk of spoiling the implant as implant folding continues with the pusher 36 coming closer to the folder face.

As shown in Figure 7B which corresponds to the invention, the jaws 12 and 14 move relative to each other with pivoting motion. Consequently, as these two jaws move towards each other, the semicylindrical folder walls 18 and 26 come into contact initially with one of the haptic portions 76, then with the optical portion 72, and finally with the haptic portion 74, at least in the example shown. Because the folder walls make contact with the various portions of the implant in succession, a single direction of initial folding is obtained for one

of the portions of the implant, and this folding direction is then transmitted to the other portions of the implant as the folder faces come to act thereon, thereby ensuring that the entire implant is folded in
5 uniform manner.

Figures 4 to 6 show an embodiment of a flexible implant injector 80 using a folder module of the type shown in Figures 1 to 3. The first jaw 12 is extended at one end by the body 82 of the injector. The opposite end
10 of the jaw 12 is extended by a cannula 84 which in turn extends the injection passage 36 of the jaw. Under such circumstances, the pusher member is omitted and replaced by a piston 86 whose terminal portion 88 is of
15 appropriate diameter and length to push a folded implant into the cannula 84.

CLAIMS

1/ A folder module for folding a flexible intraocular implant for injection into the eye of a patient, the module being characterized in that it comprises:

5 - two jaws that are movable relative to each other, each jaw having a folder wall constituted by a portion of a cylindrical surface and a plane wall secured to the folder wall, the two plane walls lying in parallel planes;

10 - a pivot axis orthogonal to the plane walls to control relative pivoting movement of one jaw relative to the other;

 - one of the jaws being capable of occupying relative to the other jaw a first position in which the
15 plane walls are spaced apart from each other, thereby enabling the implant to be put into place on the bottom plane wall;

 - a second position in which the plane walls face each other, whereby the folder walls and the plane walls
20 define a confinement volume for the implant; and

 - a third position in which the folder walls meet each other so as to define a substantially cylindrical volume forming a folder chamber enabling the implant to be finally folded.

25

2/ A folder module according to claim 1, characterized in that the first of said jaws further comprises two side walls parallel to said pivot axis and secured to the edges of the plane wall of said jaw, such that when the
30 two jaws are in their second relative position, the plane walls, the folder walls, and the side walls together define a storage space in which the implant can be held in a non-folded state.

35 3/ A folder module according to claim 2, characterized in that the distance between the two plane walls is greater than the thickness of the implant.

4/ A folder module according to claim 3, characterized in that the distance between the plane walls lies in the range 1 mm to 3 mm.

5

5/ A folder module according to any one of claims 2 to 4, characterized in that said jaws further comprise means for holding them in their second relative position, whereby the implant can be held in said storage volume.

10

6/ A folder module according to any one of claims 2 to 5, characterized in that said jaws further comprise means for holding them in their third relative position, whereby the implant can be held in the folded state in the folder chamber so as to enable the implant to be injected into the eye of a patient.

7/ A folder module according to any one of claims 2 to 6, characterized in that said first jaw further comprises an injection passage at one of the ends of said folder chamber on an axis that substantially coincides with the axis of the cylindrical volume defined by the folder walls when said jaws are in their third relative position.

25

8/ A folder module according to claim 7, characterized in that said first jaw further comprises a guide passage opening out to the second end of the folder chamber and having the same axis as the folder chamber, and a pusher member slidably mounted in the guide passage for pushing the implant in the folded state into said injection passage.

9/ A flexible implant injector, characterized in that it comprises:

35

- a folder module according to claim 7 or claim 8;

5 - an injector body including a housing for receiving said confinement module, an injection cannula for extending said injection passage when said confinement module is in place in said housing, and an axial guide duct for extending said guide passage when said confinement module is in place in said housing, and an axial guide duct for extending said guide passage when said folder module is in place in said housing; and

10 - a piston whose rod is slidably mounted in said axial guide duct, whereby the end of the rod of said piston can co-operate with one end of the pusher member of said folder module.

15 10/ A flexible implant injector, characterized in that it comprises:

- a folder module according to any one of claims 1 to 6;

20 - a cannula extending a first end of said confinement chamber to guide the implant in its folded state;

- a guide passage extending a second end of said guide chamber; and

25 - a piston slidably mounted in said guide passage to push the implant in the folded state from said folder chamber into said cannula.

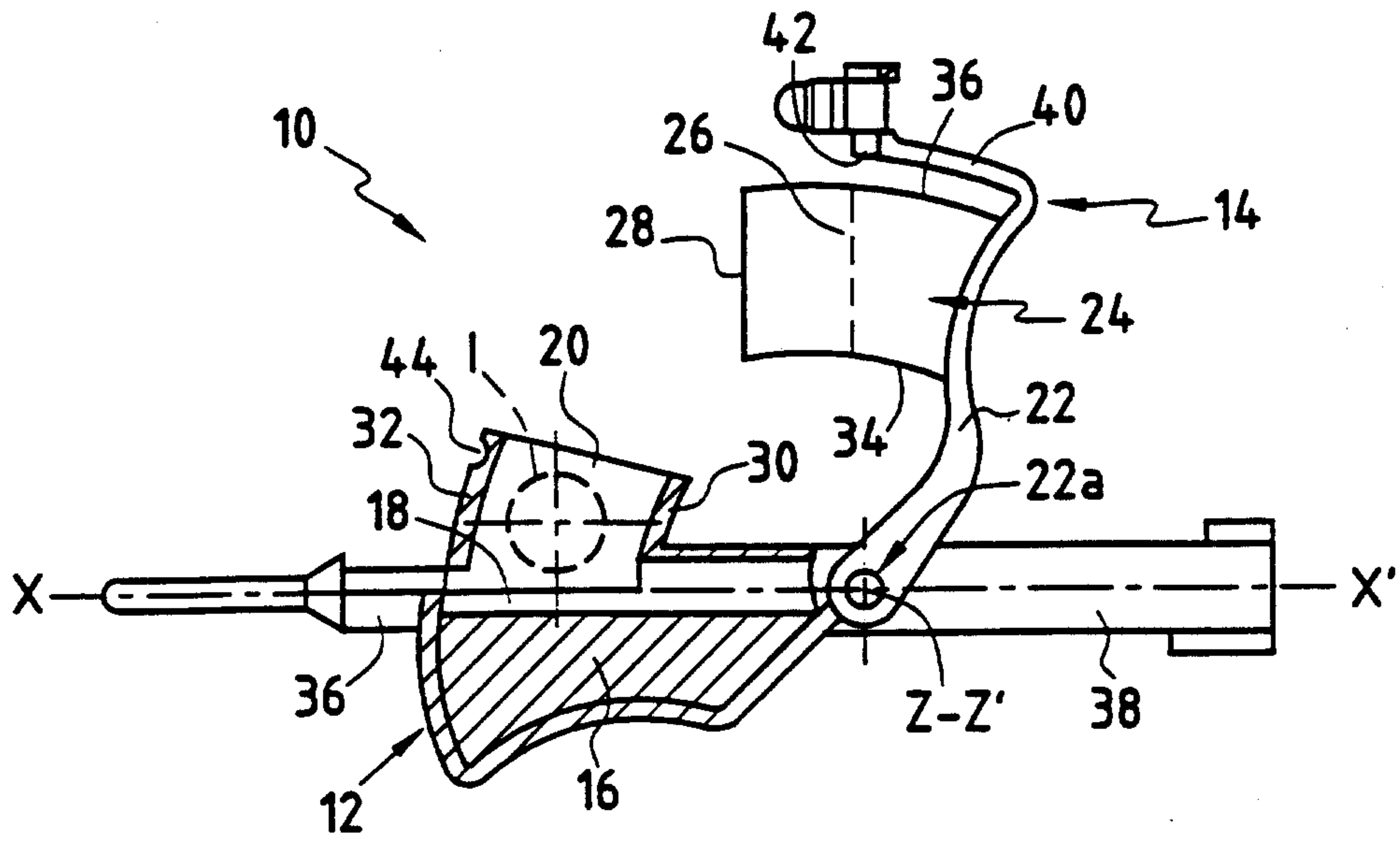

FIG. 1

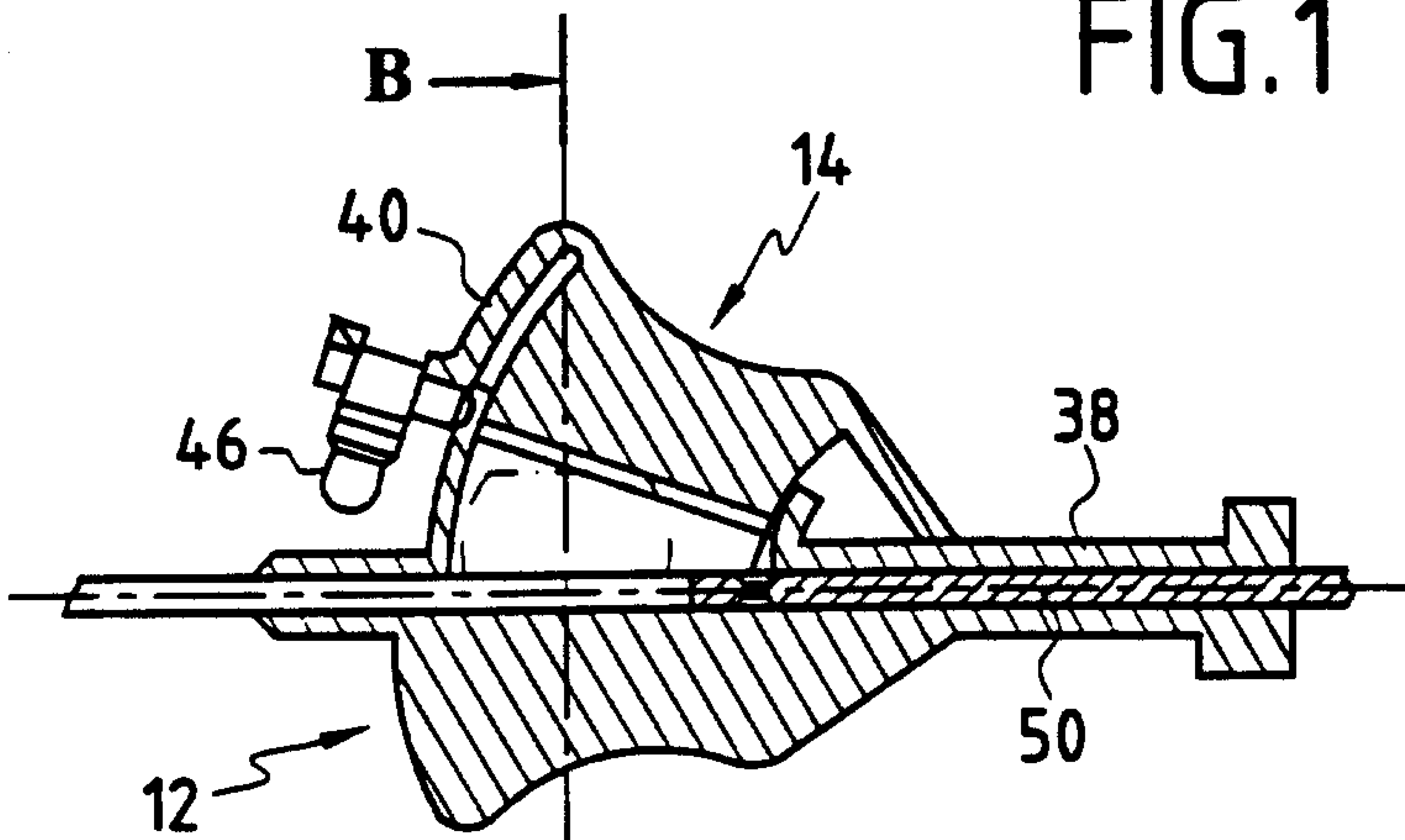

FIG. 2A

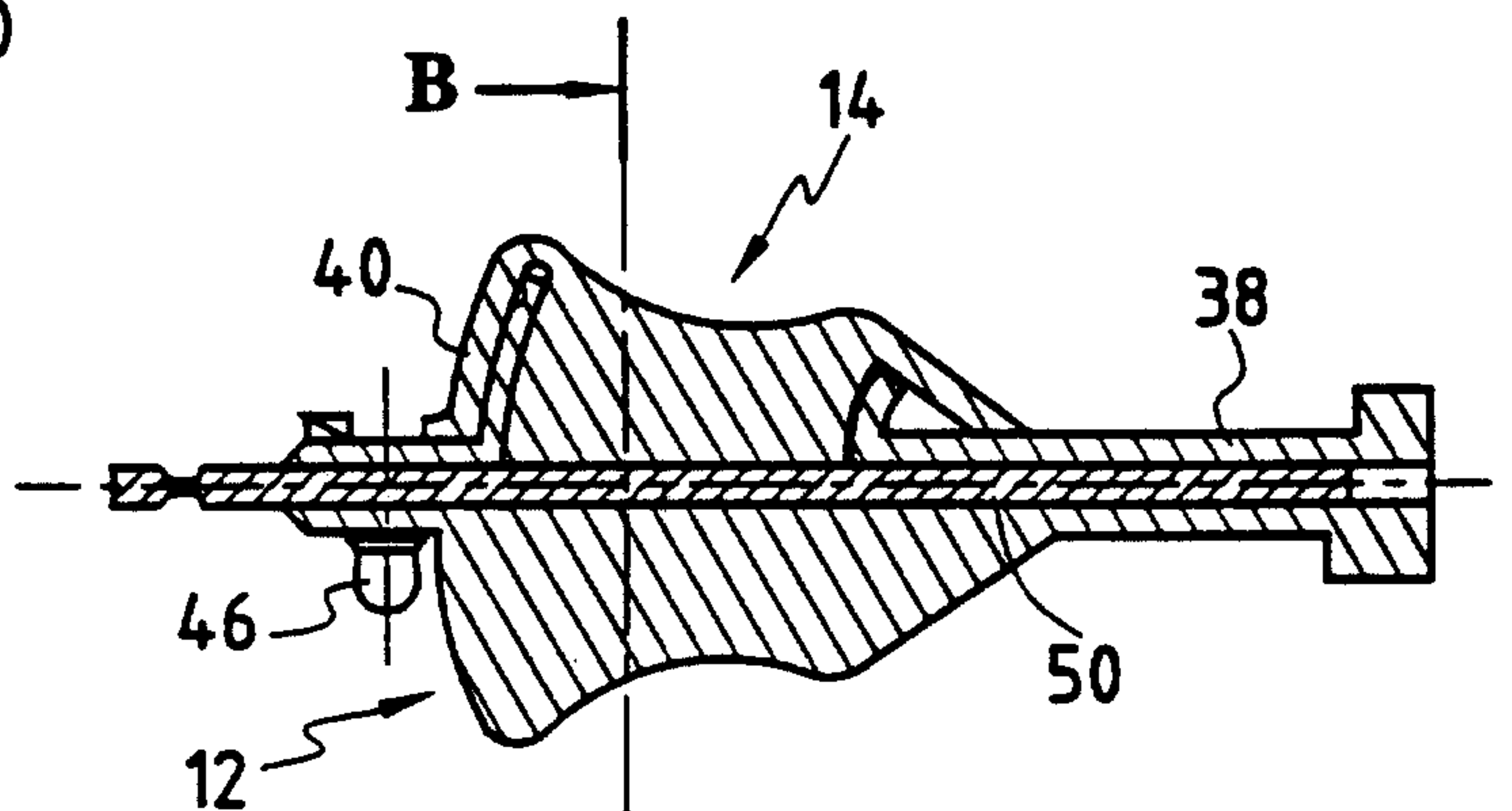

FIG. 3A

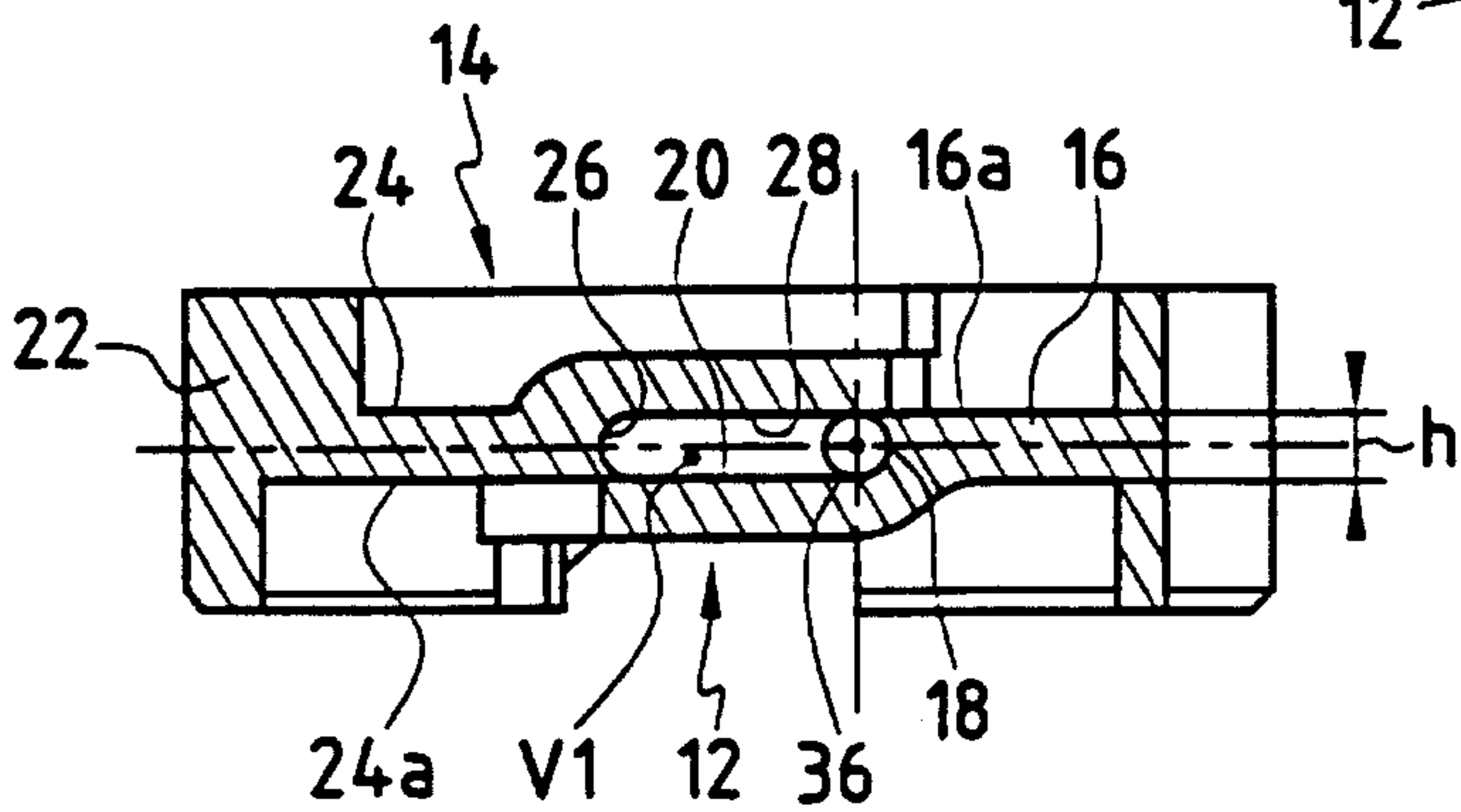

FIG. 2B

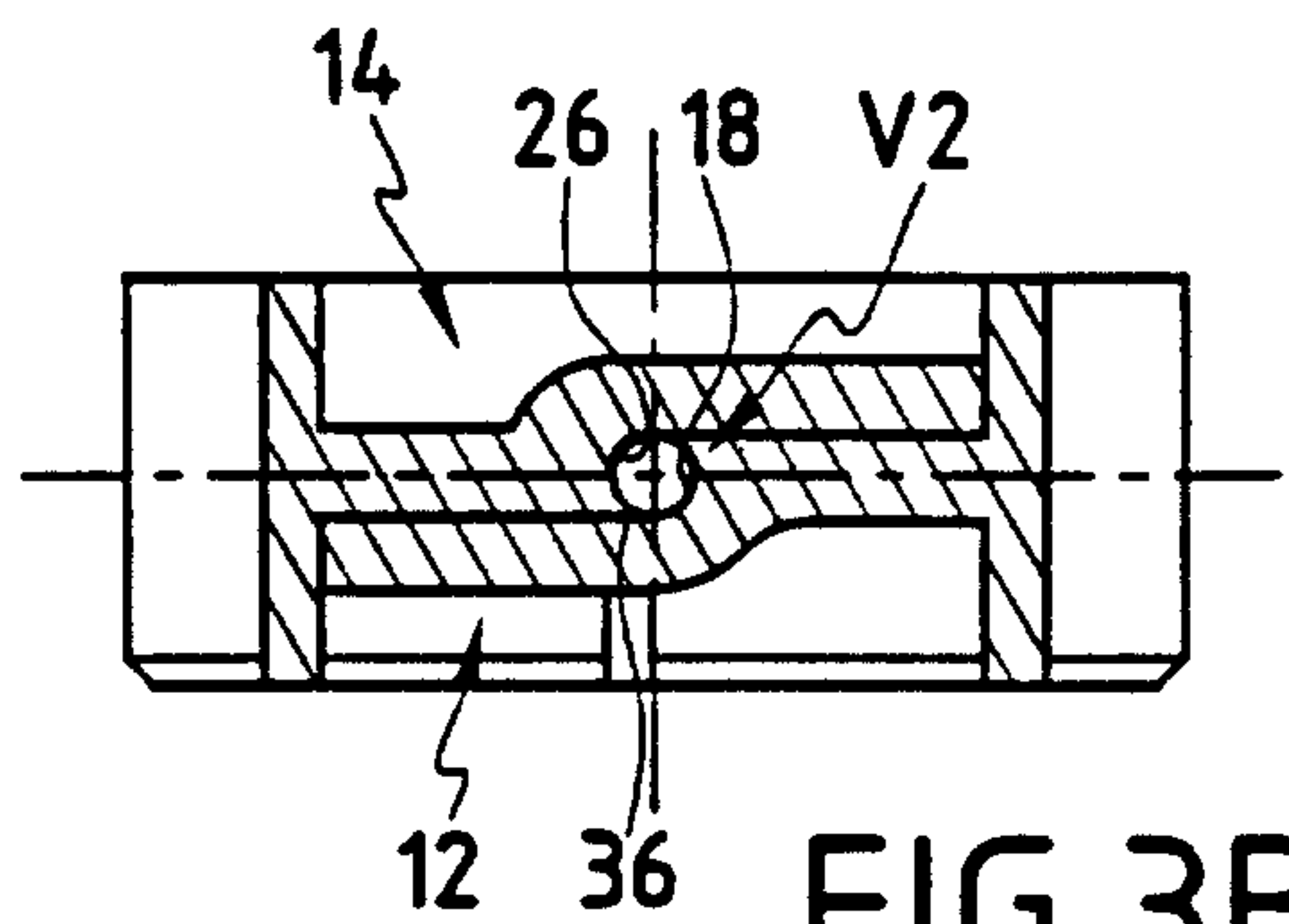

FIG. 3B

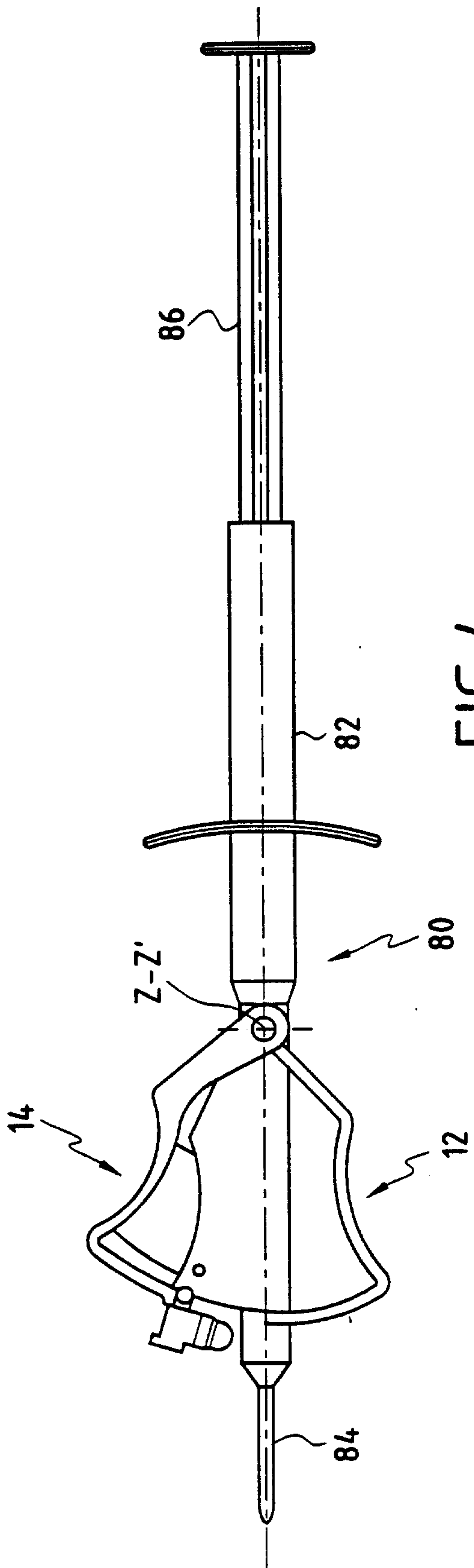

FIG. 4

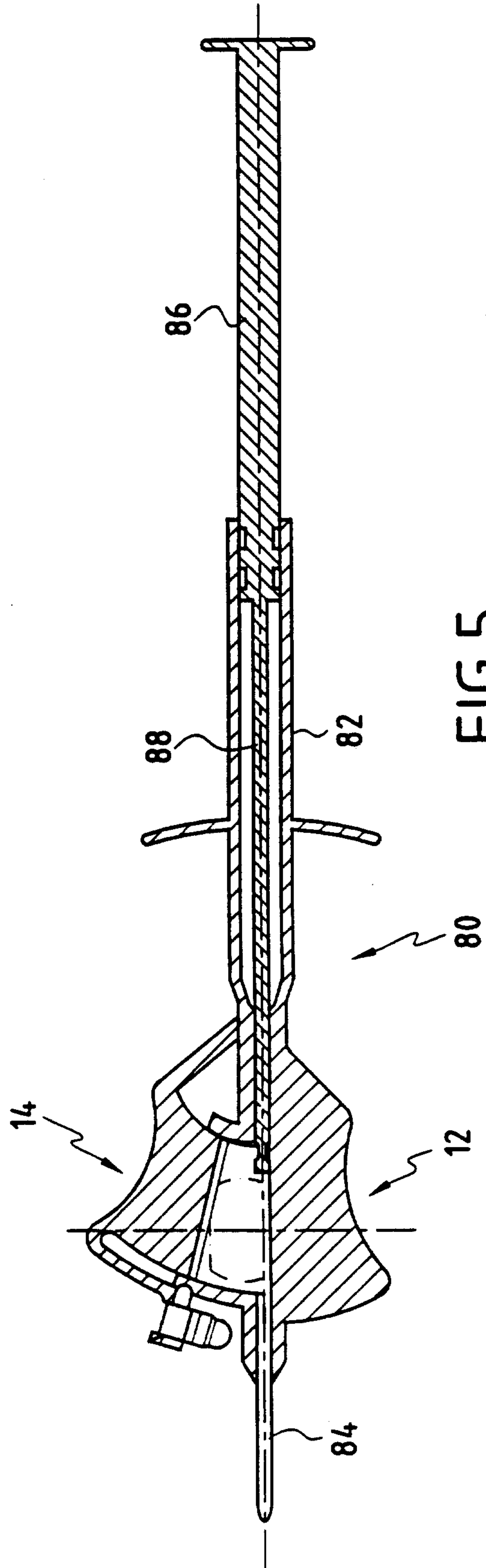

FIG. 5

