

⑫ **EUROPEAN PATENT SPECIFICATION**

- ④⑤ Date of publication of patent specification: **16.12.87** ⑤① Int. Cl.⁴: **D 06 F 37/26, D 06 F 37/22**
②① Application number: **83108538.6**
②② Date of filing: **30.08.83**

⑤④ **Laundry washing machine of the top-charging type provided with a counterweight.**

③⑨ Priority: **28.09.82 IT 3403782 u**

④③ Date of publication of application:
04.04.84 Bulletin 84/14

④⑤ Publication of the grant of the patent:
16.12.87 Bulletin 87/51

③④ Designated Contracting States:
AT BE CH DE FR GB IT LI LU NL SE

⑤⑨ References cited:
FR-A-2 218 418
FR-A-2 218 419
FR-A-2 318 261
FR-A-2 359 924

⑦③ Proprietor: **INDUSTRIE ZANUSSI S.p.A.**
Via Giardini Cattaneo 3
I-33170 Pordenone (IT)

⑦② Inventor: **Regazzo, Olindo**
Via Gasparinetti 5
I-31100 Treviso (IT)

⑦④ Representative: **Patentanwälte Grünecker, Dr.**
Kinkeldey, Dr. Stockmair, Dr. Schumann, Jakob,
Dr. Bezold, Meister, Hilgers, Dr. Meyer-Plath
Maximilianstrasse 58
D-8000 München 22 (DE)

Note: Within nine months from the publication of the mention of the grant of the European patent, any person may give notice to the European Patent Office of opposition to the European patent granted. Notice of opposition shall be filed in a written reasoned statement. It shall not be deemed to have been filed until the opposition fee has been paid. (Art. 99(1) European patent convention).

Description

The present invention relates to a laundry washing machine of the top-charging type, particularly for domestic use, provided with a counterweight for the dynamic balance of the tub-drum assembly of the machine.

As generally known, laundry washing machines of the top-charging type are at present being constructed to have the smallest possible dimensions so as to permit them to be installed in limited spaces.

The efficient dynamic balance of the tub-drum assembly of laundry washing machines of this type requires the employ of at least one counterweight formed of a material having a high specific weight. This material may be contained in a suitably formed container or may itself be formed to a compact block. The counterweight is generally attached to the outer periphery of the tub at a lower or lateral portion thereof. This manner of mounting the counterweight requires it to be considerably heavy and thus to have relatively great dimensions, so that the accommodation of the counterweight in a washing machine of reduced dimensions offers considerable difficulties.

It is therefore an object of the present invention to eliminate this disadvantage by providing a counterweight of the described type which is mounted on the top portion of the tub of the machine adjacent the access opening thereof.

The location of the counterweight in this position results in an upwards displacement of the center of gravity of the tub-drum assembly, whereby the lever arm of the center of gravity with respect to the suspension points of the tub-drum assembly within the frame of the machine is correspondingly shortened.

This permits a counterweight of reduced weight and dimensions as compared to hitherto employed counterweights to be employed for ensuring an efficient dynamic balance of the tub-drum assembly.

As a result, there is considerably more space available in the washing machine for mounting the counterweight itself or for installing the various electrical and mechanical components of the machine.

In addition, the formation of the counterweight requires a smaller amount of material, with the attendant economical advantages.

These and other objects are attained according to the invention by a laundry washing machine of the top-charging type, particularly for domestic use, comprising a tub suspended in a frame of the machine, a drum rotatably mounted in said tub and provided with two spring-biased peripheral doors adapted to partially overlap one another in the closed position, and a counterweight of a material having a high specific weight for the dynamic balance of the tub-drum assembly, said tub being provided with a top opening giving access to said drum.

In accordance with the invention, a laundry

washing machine of the above specified type is characterized in that said counterweight is formed with at least one central through-opening and is mounted on the top portion of said tub, so that said through-opening coincides with said access opening and with a charging port formed in the frame of the machine, flexible means being provided to connect to the respective peripheral borders of said counterweight and said charging port.

The characteristics of the invention will become more evident from the following description, given by way of a non-limiting example with reference to the accompanying drawings, wherein:

fig. 1 shows a partially sectioned elevational view of a top portion of a laundry washing machine of the top-charging type provided with a counterweight according to the invention, and

fig. 2 shows a perspective view of the counterweight as applied to the tub-drum assembly of a laundry washing machine of the top-charging type.

Shown in figs. 1 and 2 of the drawings is a laundry washing machine of the top-charging type, comprising a washing tub 3 suspended within an outer frame 4 by means of a not shown system of upper springs and lower shock absorbers, and a drum 5 rotatably mounted within tub 3 and provided with a peripheral opening 6 adapted to be closed by spring-biased door flaps 7, only one of which is shown in fig. 1, adapted to overlap one another in the closed position.

Formed in the upper portion of tub 3 is a through-opening 8 giving access to drum 5 for introducing and discharging the laundry into and out of drum 5, respectively.

For ensuring an efficient dynamic balance of the tub-drum assembly 3—5, there is in addition provided a counterweight 9 formed of a material having a high specific weight, such as cement, baryte or the like, which may be contained within a suitably shaped container or be formed as a compact block of the selected material.

Counterweight 9 is formed with at least one central through opening 10 and with a channel-shaped outer peripheral rim 11 for purposes to be described later.

For mounting counterweight 9 in the laundry washing machine, it is located on the top portion of tub 3 in such a position that its through-opening 10 coincides with a charging port 12 formed in the frame of the machine thereabove, and with the access opening 8 of the tub. In this position the counterweight is subsequently affixed to the tub of the machine by means of bolts 13 and nuts 14 or equivalent fastener elements.

Charging port 12 is surrounded by a frame structure 15 acting as a charging funnel and having a free edge 16 partially projecting into the interior of the machine.

Connected between the free edge portion 16 of frame structure 15 and channel-shaped outer peripheral rim 11 of counterweight 9 is a bellows-

shaped flexible element 17 for permitting the laundry to be safely introduced into and withdrawn from drum 5. For connecting flexible element 17 to frame structure 15, the free edge portions 16 and 18, respectively, of the frame structure and the flexible element brought into contact with each other, whereupon a profiled rigid clamping element 19 is slipped into the contacting edge portions.

The other free edge portion 20 of flexible element 17 is introduced into the channel-shaped edge 11 of counterweight 9 and retained therein by means of an expansible annular member 21.

The flexible element 17 may have a different shape and be connected between the charging port and the counterweight in a different manner without thereby leaving the scope of the invention.

As shown particularly in fig. 1, counterweight 9 is formed with two opposing lateral edge portions 22 partially projecting into opening 10 for being engaged by hooks 23 provided on the door flaps of the drum, should the latter be rotated with its door flaps accidentally open.

The described location of the counterweight on top of the tub of the washing machine results in an upwards displacement of the center of gravity of the tub-drum assembly and thus in a shorter lever arm of the center of gravity with respect to the suspension points of the assembly within the frame of the machine.

As a result, the dynamic balance of the said assembly is achieved by employing a counterweight of the same material as above specified, although of reduced weight, so that the counterweight may be designed with reduced dimensions and formed of a reduced amount of material.

As the dimensions of the counterweight are thus reduced, its accommodation within the frame of the machine as well as that of the outer components thereof is greatly facilitated.

Claims

1. A laundry washing machine of the top-charging type, particularly for domestic use, comprising a tub suspended in the frame of the machine, a drum rotatably mounted in said tub and provided with two spring-biased peripheral doors adapted to be partially superimposed on one another in the closed position, and a counterweight of a material having a high specific weight for ensuring the dynamic balance of the tub-drum assembly, said tub being provided with a top opening giving access to said drum, characterized in that said counterweight (9) is formed with at least one central through-opening (10) and is mounted on the top portion of said tub (3) so that said through-opening (10) coincides with said access opening (8) and with a charging port (12) formed in the frame of the machine, flexible means (17) being provided to connect to the respective peripheral borders of said counterweight (9) and said charging port (12).

2. A laundry washing machine according to claim 1, characterized in that said counterweight (9) is formed with at least two opposing lateral edge portions (22) partially projecting into said through opening (10) and cooperating with corresponding hooks (23) affixed to said doors of said drum, should the latter be rotated with its door flaps accidentally open.

10 Patentansprüche

1. Waschmaschine von der von oben zu beladenden Art, speziell für den Hausgebrauch, enthaltend einen in dem Rahmen der Maschine aufgehängten Bottich, eine in dem Bottich drehbar gelagerte Trommel, die mit zwei von Federn vorgespannten Umfangstüren versehen ist, die dazu eingerichtet sind, in der Schließstellung teilweise übereinander zu liegen, und ein Gegengewicht aus einem Material hohen spezifischen Gewichts zur Erzielung des dynamischen Ausgewichts der Bottich-Trommel-Anordnung, wobei der Bottich mit einer oberen Öffnung versehen ist, die Zugang zu der Trommel gewährt, dadurch gekennzeichnet, daß das Gegengewicht (9) mit wenigstens einer zentralen Durchgangsöffnung (10) versehen ist und am oberen Abschnitt des Bottichs (3) derart montiert ist, daß seine Durchgangsöffnung (10) mit der Zugangsöffnung (6) und einer Ladeöffnung (12), die in dem Rahmen der Maschine ausgebildet ist, zusammenfällt, wobei eine flexible Einrichtung (17) zur Verbindung der entsprechenden Umfangsränder des Gegengewichtes (9) und der Ladeöffnung (12) miteinander vorgesehen ist.

2. Waschmaschine nach Anspruch 1, dadurch gekennzeichnet, daß das Gegengewicht (9) mit wenigstens zwei entgegengesetzten quer vorstehenden Randabschnitten (22) versehen ist, die teilweise in die Durchgangsöffnung (10) vorstehen und mit entsprechenden Haken (23) zusammenwirken, die in den genannten Türen der Trommel vorgesehen sind, sollte letztere bei versehentlich offenen Türklappen in Drehung versetzt werden.

Revendications

1. Machine à laver le linge à chargement par le dessus, destinée notamment à l'usage domestique, comprenant une cuve suspendue dans le bâti de la machine, un tambour monté en rotation dans la cuve et comportant deux portes périphériques rappelées par ressorts adaptées pour se recouvrir partiellement l'une l'autre dans la position fermée, et un contrepoids en une matière de densité élevée pour assurer l'équilibrage dynamique de l'ensemble cuve-tambour, cette cuve comportant une ouverture supérieure donnant accès au tambour, caractérisée en ce que le contrepoids (9) présente au moins une ouverture centrale traversante (10) et est monté sur la partie supérieure de la cuve (3) de telle sorte que cette ouverture traversante (10) coïncide avec l'ouverture d'accès (8) et avec une ouverture de charge-

ment (12) formée dans le bâti de la machine, des moyens flexibles (17) étant prévus pour relier les bords périphériques respectifs du contrepoids (9) et de l'ouverture de chargement (12).

2. Machine à laver le linge selon la revendication 1, caractérisée en ce que le contrepoids (9) comporte au moins deux portions marginales

latérales opposées (22) se projetant partiellement dans l'ouverture traversante (10) et coopérant avec des crochets correspondants 23 fixés sur les portes du tambour, au cas où ce dernier tournerait avec ses battants de porte accidentellement ouverts.

10

15

20

25

30

35

40

45

50

55

60

65

4

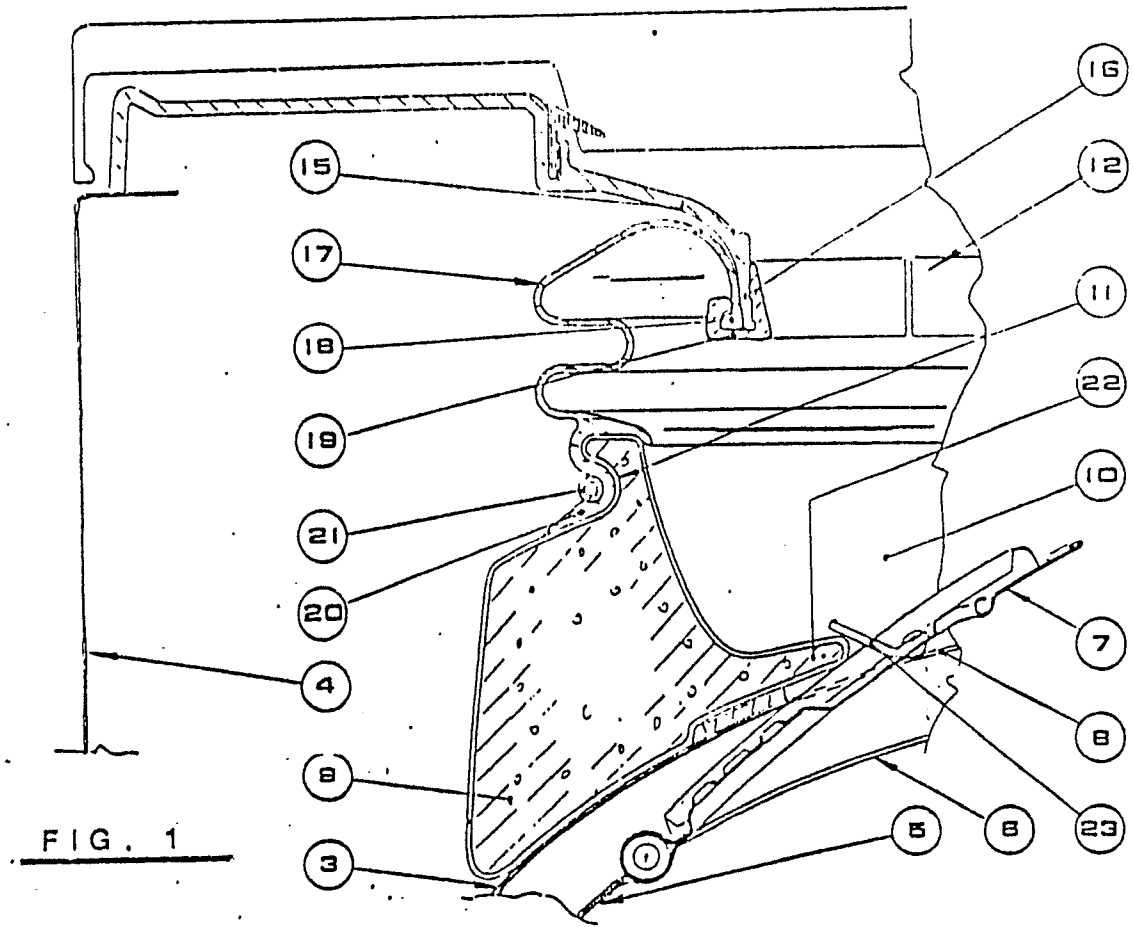

FIG. 2

