



(12) **EUROPEAN PATENT APPLICATION**

(43) Date of publication:  
24.03.1999 Bulletin 1999/12

(51) Int. Cl.<sup>6</sup>: **H01Q 1/38**, H01Q 1/12

(21) Application number: **98116584.8**

(22) Date of filing: **02.09.1998**

(84) Designated Contracting States:  
**AT BE CH CY DE DK ES FI FR GB GR IE IT LI LU  
MC NL PT SE**  
Designated Extension States:  
**AL LT LV MK RO SI**

(72) Inventor: **Vernon, Peter  
Maroubra, NSW 2035 (AU)**

(30) Priority: **19.09.1997 AU PO9298/97  
17.06.1998 US 98771**

(74) Representative:  
**Patentanwälte  
Westphal, Mussnug & Partner  
Waldstrasse 33  
78048 Villingen-Schwenningen (DE)**

(71) Applicant: **Vernon, Peter  
Maroubra, NSW 2035 (AU)**

(54) **Planar antenna device and a method for providing conductive elements on a substrate**

(57) A antenna arrangement is disclosed for use in vehicles and other application where the antenna can be affixed to a surface, e.g. a window. The antenna 10 is formed from 2 square elements 12,13, defined within a rectangle. Additional square elements 17, 18 may be defined within the other square elements. The dimensions may be chosen so as to maximise gain for selected radio frequencies. Also disclosed is a method for providing conductive elements on a substrate, including printing a conductor pattern onto a substrate using conductive ink, and using the deposited pattern as an electrode for an electroplating process.

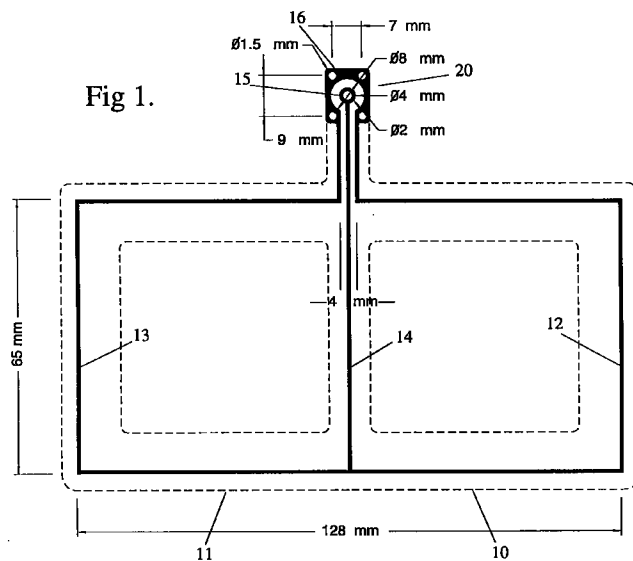

## Description

### Technical Field

[0001] The present invention relates to antennas intended to be affixed to surfaces, for use with radio frequency devices such as cellular phones, GPS location systems, and other RF applications. The present invention further relates to a method for manufacturing conductive patterns on substrates.

### Background Art

[0002] Many applications currently exist where an RF antenna is provided in order to enable communication - for example, cellular telephones, GPS systems, wireless data networks and the like. In some cases the antenna is provided with the device, for example as a stub unit on a cellular phone. In other cases, however, it is necessary to provide an externally connected antenna. Further, in applications such as in-car use of cellular phones, it is desirable to provide an additional antenna to boost signal strength. Traditional antennas for this purpose have been generally externally mounted on the vehicle. This increases wind noise, is prone to vandalism, and detracts from the appearance of the vehicle.

[0003] For any antenna application of this type, various issues need to be considered. Apart from addressing the problems mentioned above, the antenna should provide maximum capture area, whilst ideally being visually unobtrusive. It should be simple to install, yet electrically and structurally reliable.

[0004] It has been proposed to provide an antenna by adhering an array to the inside of a window of a motor vehicle. US Patent No. 5363114 to Shoemaker describes a planar, serpentine antenna which is adhered to a carrier layer, and which is then adhered to a suitable vehicle surface. The antenna is disclosed as having a serpentine patterned arrangement.

[0005] It is an object of the present invention to provide an improved antenna for mounting on planar surfaces.

### Summary of Invention

[0006] According to one aspect the present invention provides a planar antenna including a rectangular conductive element formed from two square elements, the square elements being defined within the rectangle by a centrally located return conductor. Each square element is connected at one end to a connector element, and at the other end to the return conductor. The lengths of the elements are chosen so as to maximise gain for the RF frequencies of interest.

[0007] In a preferred form, the antenna further includes one or more additional square elements disposed within the square elements of the antenna, each

being connected to the respective larger square at one end and to the return conductor at another point. The additional square elements can be sized for optimal reception of additional frequencies.

[0008] It will be understood that the term planar is intended to mean both flat surfaces and smooth curved surfaces, such as for example the shape of a vehicle windshield.

[0009] The inventive antenna arrangement has a number of advantages over the existing designs. The intended applications, where the antenna is adhered to an existing surface such as a window, do not require that the conductive elements be structurally rigid themselves, thereby enabling the use of a sparse geometry. This also enables the antenna to have a relatively large capture area, as it is mounted on a surface and not free-standing. Further, as there are elements disposed both horizontally and vertically, the antenna can receive either vertically or horizontally polarised signals well, which is advantageous in applications where scattering due to buildings and other structures occurs.

[0010] In the preferred implementation, the antenna also has the advantage of not requiring impedance matching electronics. A simple square antenna of the proportions of one of the square elements forming the antenna, with conductors 1mm wide and 25 microns thick, has an impedance of about 100 ohms. Because the present antenna arrangement has in effect two impedances of this size in parallel, the impedance is about 50 ohms, and so the inventive antenna can be directly connected to a standard 50 ohm cable. This reduction in impedance is inherent in the design.

[0011] According to another aspect the present invention provides a method for providing conductive elements on a substrate, including the steps of:

printing a desired conductor pattern onto a substrate, using conductive ink; and  
electrodepositing further conductive material onto the conductor pattern, using the pattern formed from conductive ink as an electrode in an electroplating process.

[0012] The conductive material may be conveniently copper. The parameters of the electroplating process will depend upon the process selected, but should be such as to provide an adequate thickness of copper, but not so much that too much copper is deposited and the pattern becomes vulnerable to mechanical failure. The inventor has found that in the cellular phone application a thickness of about 25 microns is suitable.

[0013] The pattern is suitably printed using a screen printing process. In practice, a large sheet of flexible material can be printed and cut using a suitable tool to provide many antenna arrays.

[0014] After depositing, preferably a double sided adhesive film, preferably transparent, is applied both to provide a mechanism for adhesion to the desired sur-

face, and to inhibit corrosion of the copper.

[0015] The inventors have investigated various methods for practical manufacture of the antenna. Whilst the invention arose in this context, it will be understood that the inventive method can equally be applied to manufacture of other conductor on substrate devices. The use of conductive ink alone did not provide suitable resistive properties for the antenna, and the addition of electrodeposition to the printing approach was only arrived at after significant trial and error.

### Brief Description of Drawings

[0016] An embodiment of the present invention will now be described with reference to the accompanying drawings, in which:

Figure 1 is a plan view of one embodiment of the inventive device;

Figure 2 is a plan view of a second embodiment of the inventive device;

Figure 3 is a schematic illustration showing connection of the device of Figure 2 to enable multiple device connection;

Figure 4 is an exploded view of the connector arrangement; and

Figure 5 is a flowchart illustrating the inventive process.

### Detailed Description

[0017] The present invention is principally described in terms of a device designed to be adhered to a surface as an add-on device. However, it will be appreciated that the inventive antenna design could be formed as part of an article or within, for example, part of a vehicle or a casing for an electronic device.

[0018] Referring to Figure 1, an embodiment of the present invention suitable for use for cellular telephone frequencies is shown. The device 10 is shown with dimensions suitable for 900 MHz +/- 50MHz - however, it will be understood that the dimensions can be altered for any desired band.

[0019] Antenna 10 is generally rectangular in shape, and is formed from two elements 12, 13. Each of these is connected to the outer part 16 of connector element 20. Central element 14 forms the common side of the square formed by both elements 12, 13 and is connected to the center component 15 of connector 20.

[0020] The antenna dimensions are shown on the figure. The tracks are desirably about 1mm across and about 30 microns thick, including both the conductive ink and the copper. Although the corners are shown as right angles, the corners may be rounded if desired. The antenna elements are mounted on a sheet 11, shown in dotted outline, of suitable flexible material. This may be any suitable substrate, for example clear polyester, or any material used for flexible PCBs. It is preferred that

the material be transparent, particularly for in-vehicle use, so as to minimise the obstruction to vision. In the applications discussed, the film is suitably between 75 and 300 microns thick.

5 [0021] It is desirable for the dimensioning of the antenna to be a full wavelength or multiples of the wavelength of the intended signal, so that the antenna can operate independently of a ground-plane or earth. A full wave loop is a simple square. It is known that the gain of a full wave loop over an isotropic (point source) radiator is 3 dB. For two such loop being fed simultaneously the gain would be an additional 3dB, giving a total of 6dB. However, as the central element 14 is common to both loops 12,13, the realised gain is 4.5dB.

10 [0022] The appropriate length for the elements of the antenna can be determined from the formula:

$$L = K/F$$

20 where L is the length, F is the frequency, and K is a constant which varies with the dielectric properties of the material surrounding the conductor. In the case of the implementation described, the dielectric properties of the substrate need to be considered. It will be appreciated that in use the dielectric properties of the surface adhered to, for example the windshield glass, will also be relevant to the constant K and consequently to the length L.

25 [0023] Figure 2 shows a preferred form of the present invention, in which additional elements 17, 18 are provided respectively inside elements 13, 12. The additional elements provide an antenna adapted for reception of different frequency bands. Each element 17,18 is connected to the central element 14 and to its respective outer element 13, 12 near the connection point.

30 [0024] This design is based upon a recognition that for many applications reception on multiple bands is useful, and also that multiple harmonics of the 900Mhz band fall close to other bands, in this case the Global Positioning Satellite (GPS) band at 1575MHz, and Personal Communication System (PCS) band at 1800-2000 MHz. The additional elements allow for proper resonance on these bands. Using the same methodology as described above, the theoretical gain for GPS band is 6dB and for PCS is 7.5dB. It will be understood that it is possible within the scope of the present invention to have further additional elements within elements 17, 18 if desired to provide additional band coverage for certain applications.

35 [0025] The inventor had difficulty in determining an appropriate manufacturing process for the present invention, and several problems became apparent. The standard technique used for flexible PCBs made from materials such as polyester is to screen print silver based polymer conductive ink, for example Acheson Electrodag 477SS. For the usual applications a resistivity of about 0.01 ohm/square is acceptable. However, for

high frequency radio signals, a lower resistivity is desirable, and the use of solid copper tracks was indicated. Although copper track flexible PCBs are used in other applications, the finished product produced is not acceptable for the present application. The material used is not suited chemically to standard PCB etching processes - particularly in terms of remaining transparent and of acceptable appearance after processing.

[0026] The inventive process is described by the flow chart shown in Figure 5. Initially the desired art work is prepared. This in use will normally be many - for example 20 - antenna units on a single sheet. The artwork is then screen printed onto the film using a suitable conductive ink. The screen printing must be done to a suitable level of detail - for example, using a 230 mesh stainless steel printing screen. This is then cured and dried as required for the ink - for example, using Acheson Electrodag 477SS for about 8 minutes at 150° C in a conveyerised convection oven.

[0027] The sheet is then placed in an electroplating bath, with the conductors arranged to act as the depositing electrode. The solution, time and current will depend on the specific process used. However, particular care needs to be taken with current levels in the conductive track. The electroplating should produce a sufficiently thick layer on the track, for example 25 microns. This provides an antenna with a track resistance of about .001 ohm/square, and leaves the substrate transparent.

[0028] In order to produce a bright and unblemished finish, the following steps are desirable. A fresh solution of electrolyte, for example Cuprax, should be used and must not have any form of contamination, for example from previous use of the solution. In standard electroplating some degree of contamination can be tolerated - this is not feasible for the present application.

[0029] Initial plating current is low, for example about 4 Amps for 5 minutes. This is so that a thin layer of copper is deposited on the conductive ink, and in turn carries the higher current required for normal electroplating processes. If a higher current is used, the conductive ink overheats causing potential problems. The conductive ink may separate from the substrate, or leave discoloration or burn marks. The final current used is 8-10 Amps for a further 10 minutes.

[0030] A double sided clear adhesive, for example 3M laminating adhesive, is then applied to the copper track side of the polyester film. This provides a means of attachment to the mounting surface, and inhibits oxidation of the copper. A suitable arrangement, for example a guillotine or knife tool, is then used to remove each antenna device from the film sheet.

[0031] A further problem relates to affixing a connector to the completed film antenna. The clear film used in the preferred implementation cannot tolerate the high temperatures involved with, for example, soldering. Figure 4 shows in exploded view an arrangement developed by the inventor to enable connection.

[0032] Element 20 is the connection part of the copper track. It will be appreciated that this is held between the substrate film 11, and the double sided adhesive film (not shown) and so the contacts are not exposed for simple connection. Shim 21 is placed below element 20, and socket 22 above element 20. Conductive rivets, for example of brass, are inserted through the openings 24,25,26,27 in the shim, through element 20, and through the corresponding holes in socket 22. This provides an electrical connection between the body of socket 22 and the outer part 16 of element 20. A further rivet passes through the central part 15 of element 20 and into the central part of socket 22. Plug 23 can then be readily connected illustratively by a force-fit mechanical connection, so as to provide a cable link to the device for connection to the antenna.

[0033] Figure 3 illustrates a connection arrangement for a device according to figure 2 - where multiple bands are received, and it is desired to connect these to separate devices. Illustratively, these are a cellular phone and a GPS receiver. Antenna 30 is connected via socket 22 to plug 23 on cable 24. Cable 24 connects the antenna to antenna power splitter unit 25. This then provides a connection 26 for a cellular phone, and a connection 27 for a GPS receiver.

[0034] Devices suitable for use as the antenna power splitter 25 are commercially available. The function of this device is to isolate the output ports 26, 27 from each other so that the respective devices do not interfere with each other. In this specific context, the concern would be to ensure that the cellular phone's transmit energy does not find its way to the GPS receiver. It is desirable that the antenna power splitter would have an isolation factor of at least -25dB in this application. It will be appreciated that the necessary isolation will depend on the devices intended to be connected to the antenna 30.

[0035] It will be understood that while the present invention is described mostly in the context of an in-vehicle antenna adhered inside a window, many other applications exist. The inventive antenna could be adhered to an internal or external building wall, or used to implement a wireless LAN or other data network. It could be readily used, with modifications to suit band changes, for mobile or fixed data logging and transfer.

[0036] The inventive method could be applied wherever a highly conductive pattern is required, particularly where a transparent substrate is used.

[0037] Variations and additions are possible within the general scope of the inventive concept, as will be apparent to those skilled in this field.

#### Claims

1. A planar antenna, characterised in that said antenna comprises a rectangular conductive element formed from two square elements, the square elements being defined within the rectangle by a centrally located return conductor, each said

- square element being connected at one end to a connector element, and at the other end to said return conductor, wherein the dimensions of the square elements are chosen so as to maximise gain for selected radio frequencies. 5
2. An antenna according to claim 1, wherein the conductive elements are formed on a substrate.
3. An antenna according to claim 2, wherein the substrate is a flexible film. 10
4. An antenna according to claim 2 or claim 3, wherein the substrate is transparent. 15
5. An antenna according to claim 1, wherein both square elements are electrically connected to the same connector element, and the return conductor is connected to an electrically separate connector element. 20
6. An antenna according to claim 1, wherein said antenna further includes one or more additional square elements disposed within said square elements, each additional square element being connected to the respective square element at one end and being defined by the return conductor on one side. 25
7. An antenna according to claim 6, wherein the conductive elements are formed on a substrate. 30
8. An antenna according to claim 7, wherein the substrate is a flexible film. 35
9. An antenna according to claim 7 or claim 8, wherein the substrate is transparent.
10. An antenna according to claim 6, wherein both square elements are electrically connected to the same connector element, and the return conductor is connected to an electrically separate connector element. 40
11. A method for providing conductive elements on a substrate, characterised in that the method includes the steps of: 45
- printing a conductor pattern onto a substrate, using conductive ink; and 50
- electrodepositing further conductive material onto the printed conductor pattern, using the pattern formed from conductive ink as an electrode in an electroplating process. 55
12. A method according to claim 11, wherein the substrate is flexible.
13. A method according to claim 11 or claim 12, wherein the substrate is transparent.
14. A method according to claim 11, wherein the conductor pattern is screen printed onto said substrate.
15. A method according to claim 14, wherein a plurality of conductor patterns are printed onto said substrate, and after electrodeposition a protective film is applied to the conductor pattern.
16. A method according to claim 15, wherein after the film is applied the substrate is cut to form a plurality of devices.
17. A method according to claim 15 or claim 16, wherein the film is adhesive on both sides.
18. A device including conductive elements formed by the method of claim 11.



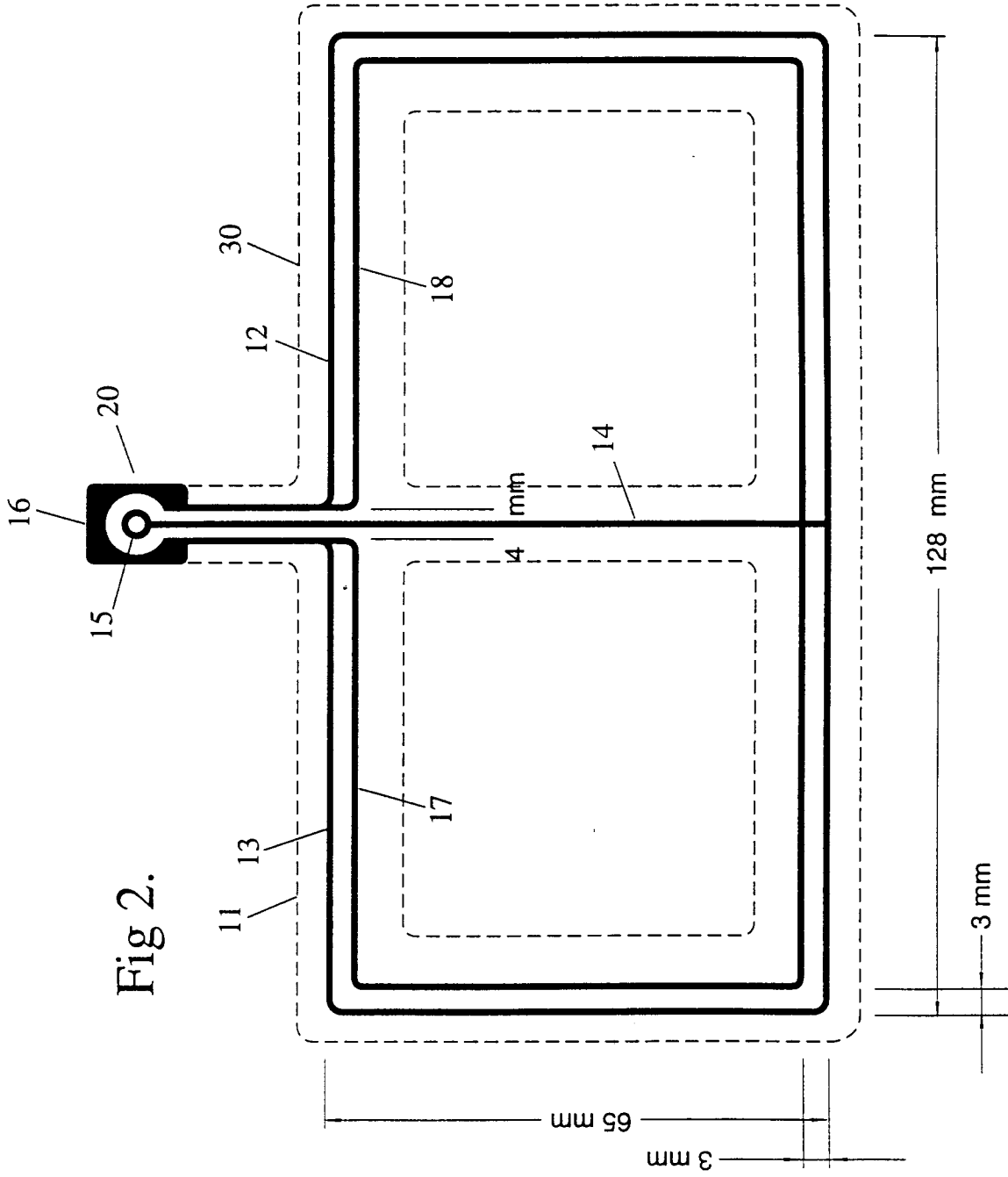

Fig 3.

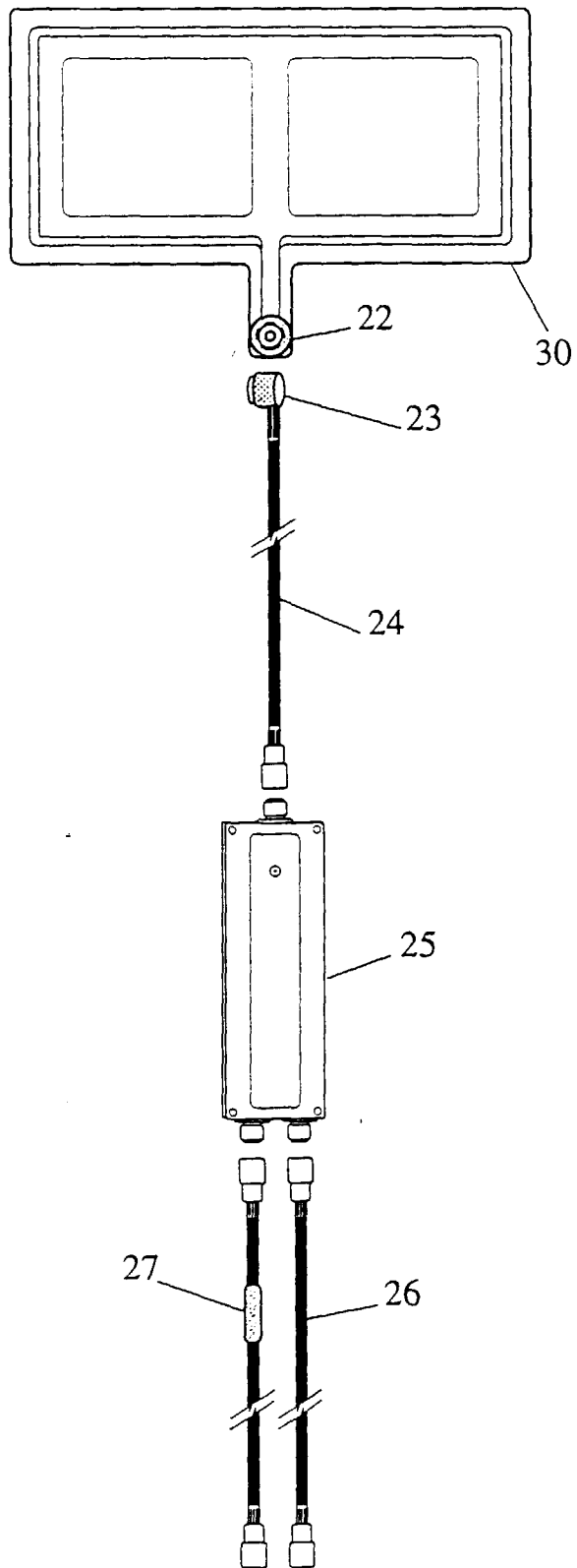

Fig 4.

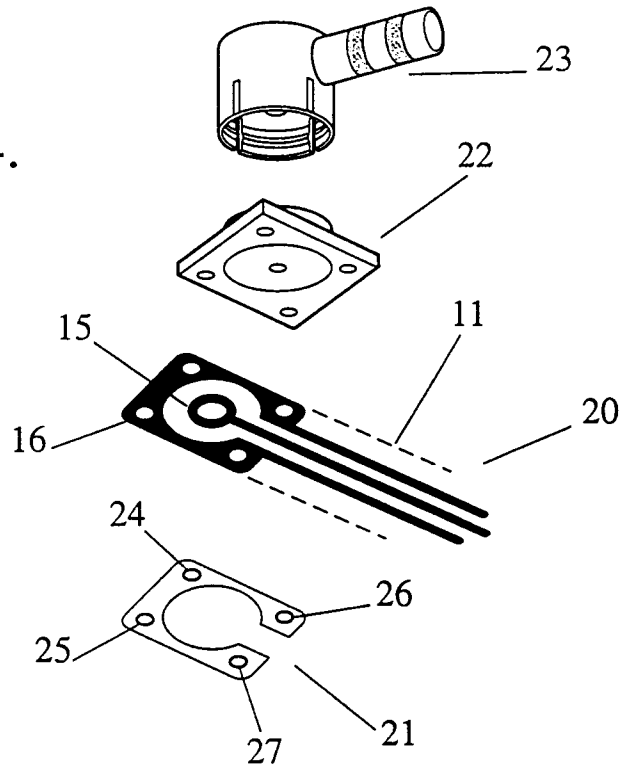

Fig 5.

