



US0D1069043S

(12) **United States Design Patent**
Kay et al.

(10) **Patent No.:** **US D1,069,043 S**

(45) **Date of Patent:** **** Apr. 1, 2025**

(54) **INLET ADAPTER COMPONENT**

(71) Applicant: **Lam Research Corporation**, Fremont, CA (US)

(72) Inventors: **Danae Nicole Kay**, Austin, TX (US);
Thomas Mark Pratt, Los Gatos, CA (US);
Matthew Palmer Kwan, Pleasanton, CA (US)

(73) Assignee: **Lam Research Corporation**, Fremont, CA (US)

(**) Term: **15 Years**

(21) Appl. No.: **29/819,868**

(22) Filed: **Dec. 17, 2021**

(51) **LOC (15) Cl.** **23-07**

(52) **U.S. Cl.**
USPC **D23/259; D23/262**

(58) **Field of Classification Search**
USPC D23/259–261, 206, 209, 217, 229,
D23/237–238, 249, 257–258, 267–268,
(Continued)

(56) **References Cited**

U.S. PATENT DOCUMENTS

D380,535 S * 7/1997 Joergensen D23/209
D663,385 S * 7/2012 Marquis-Martin D23/259
(Continued)

OTHER PUBLICATIONS

“Japanese Application Serial No. 30-2022-0023865, Response filed Apr. 20, 2023 to Preliminary Examination Report mailed Feb. 26, 2023”, w o English claims, 7 pgs.

Primary Examiner — Jennifer Rivard
Assistant Examiner — Jonathan E Fiencke

(74) *Attorney, Agent, or Firm* — Schwegman Lundberg & Woessner, P.A.

(57) **CLAIM**

The ornamental design for an inlet adapter component, as shown and described.

DESCRIPTION

FIG. 1 is a front view of an inlet adapter component, showing our new design.
FIG. 2 is a rear view thereof.
FIG. 3 is a right side view thereof.
FIG. 4 is a left side view thereof.
FIG. 5 is a top view thereof.
FIG. 6 is a bottom view thereof.
FIG. 7 is a first front-bottom-right perspective view thereof.
FIG. 8 is a first rear-bottom-right perspective view thereof.
FIG. 9 is a first front-bottom-left perspective view thereof.
FIG. 10 is a first rear-bottom-left perspective view thereof.
FIG. 11 is a front-top-right perspective view thereof.
FIG. 12 is a rear-top-right perspective view thereof.
FIG. 13 is a front-top-left perspective view thereof.
FIG. 14 is a rear-top-left perspective view thereof.
FIG. 15 is a second front-bottom-right perspective view thereof.
FIG. 16 is a second front-bottom-left perspective view thereof.
FIG. 17 is a second rear-bottom-right perspective view thereof; and,
FIG. 18 is a second rear-bottom-left perspective view thereof.
The shade lines show surface contour and not surface ornamentation. The broken lines depict portions of the inlet adapter component that form no part of the claimed design.

1 Claim, 18 Drawing Sheets

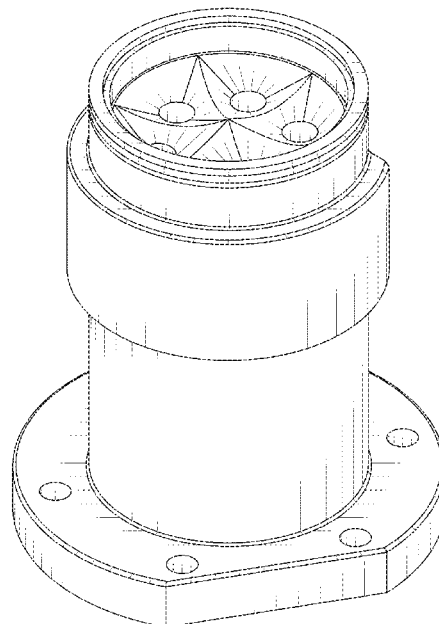

(58) **Field of Classification Search**

USPC D23/303, 355, 362-365; D8/343, 328,
 D8/399; D7/353, 387, 667; D9/435,
 D9/447; D13/154-156, 165, 173, 182
 CPC E03C 1/2306; E03C 1/262; E03C 1/22;
 E03C 1/26; E03C 1/282; E03C 1/264;
 E03C 1/12; E03C 1/2302; A47K 1/14;
 F04B 1/0443; E03F 5/04; B05B 1/00;
 B05B 1/14; A61L 9/03; F24F 8/10; B01D
 46/00; B01D 46/44; B01D 46/446; H05H
 1/245; H05H 1/46; H05H 2245/10; H05H
 1/48; H05H 1/2406
 See application file for complete search history.

D875,053 S * 2/2020 Shono D13/182
 D875,054 S * 2/2020 Shono D13/182
 D898,878 S * 10/2020 Sprenger D13/133
 D900,036 S * 10/2020 Wuester D13/151
 D905,842 S * 12/2020 Rahn D23/365
 D930,111 S * 9/2021 Pitman D23/209
 D1,010,788 S * 1/2024 Jiang D23/365
 D1,013,098 S * 1/2024 Liu D23/258
 RE50,058 E * 7/2024 Brill E03F 5/0408
 D23/259
 D1,038,886 S * 8/2024 Li D23/262
 D1,043,924 S * 9/2024 Sprenger D23/260
 D1,044,679 S * 10/2024 Hebert D23/237
 D1,051,070 S * 11/2024 Liu D13/154
 D1,051,305 S * 11/2024 Yoo D23/262
 2009/0263184 A1 * 10/2009 Riedel E03C 1/08
 403/301

(56) **References Cited**

U.S. PATENT DOCUMENTS

D668,751 S * 10/2012 Fitton D23/365
 D717,405 S * 11/2014 Coronado D23/259
 D726,869 S * 4/2015 Lepine D23/209
 D767,746 S * 9/2016 Moredock D23/365
 D781,402 S * 3/2017 Yan D23/266
 D785,775 S * 5/2017 McPhilliamy D23/364

2017/0348447 A1 * 12/2017 Lu A61L 2/14
 2018/0327283 A1 * 11/2018 Pemen B01J 19/088
 2019/0083161 A1 * 3/2019 Harle H05H 1/2406
 2021/0313155 A1 * 10/2021 Takikawa H05H 1/48
 2022/0023823 A1 * 1/2022 Reis Da Costa Labanca
 H05H 1/34
 2022/0087002 A1 * 3/2022 Sato H05H 1/2406
 2024/0287784 A1 * 8/2024 Jiang E03F 7/04

* cited by examiner

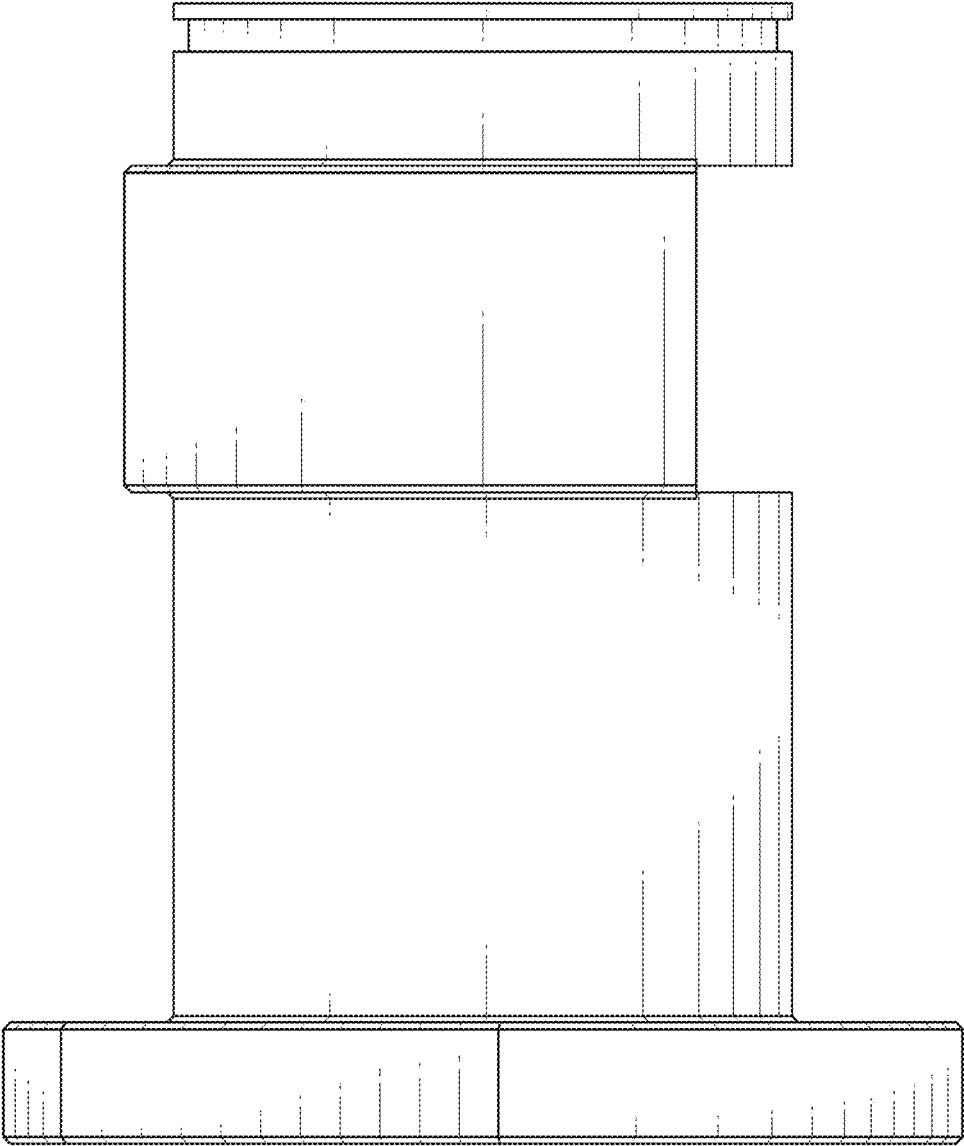

FIG. 1

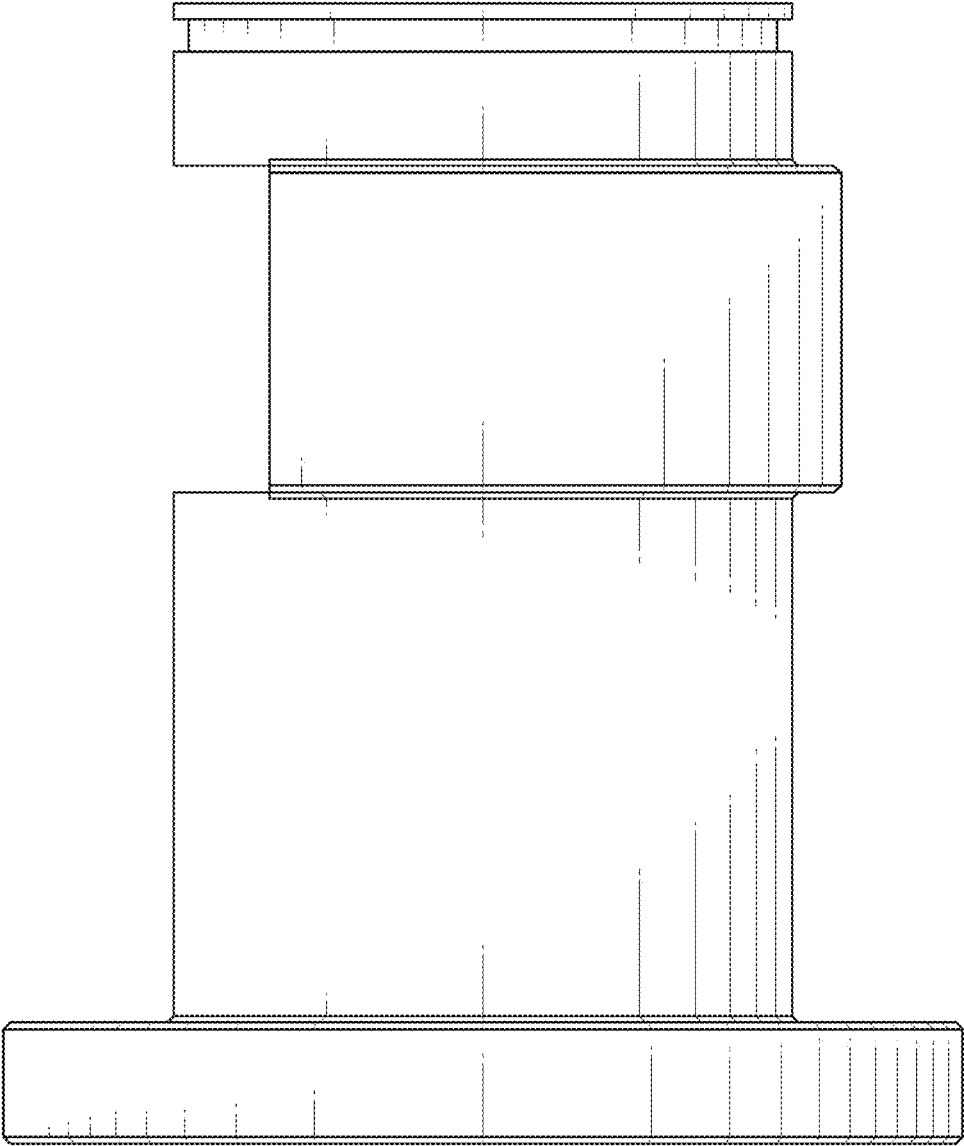

FIG. 2

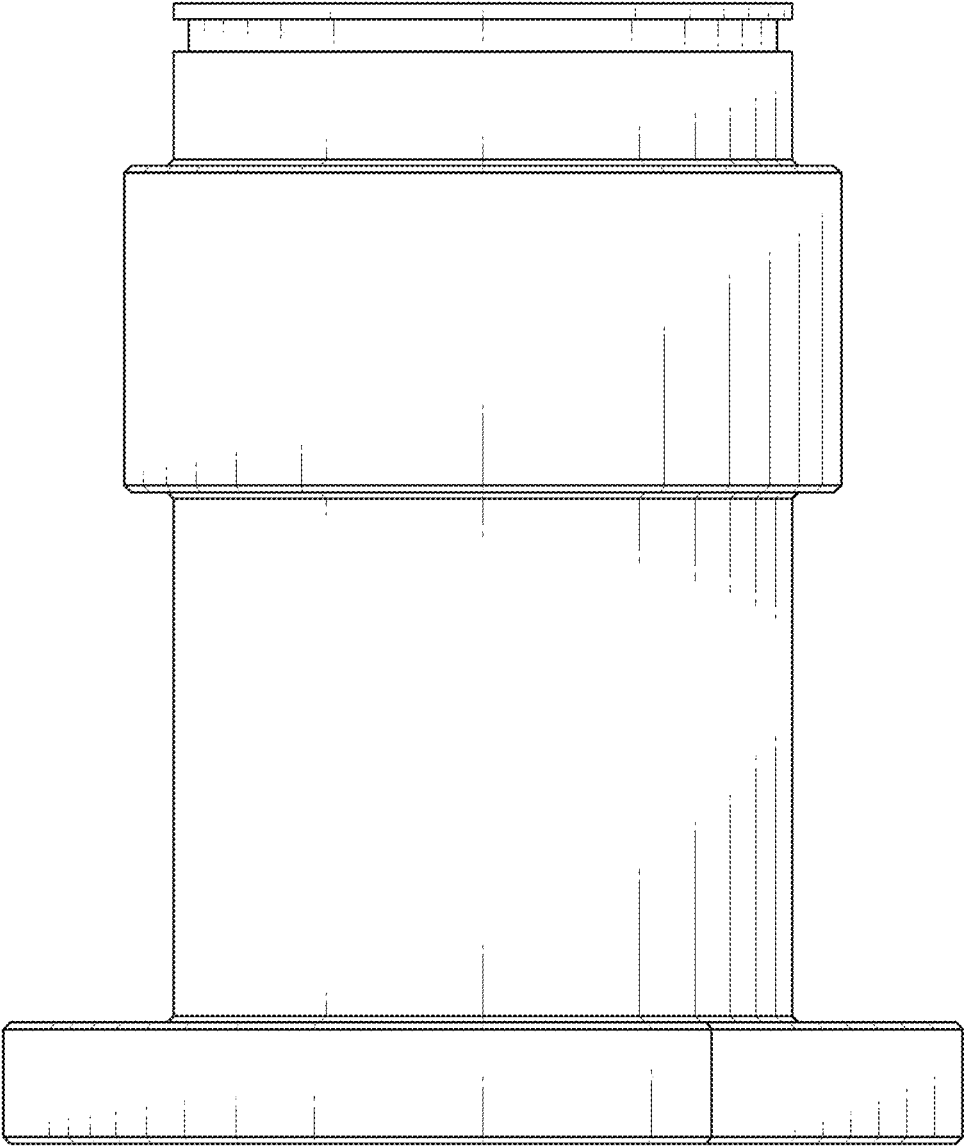

FIG. 3

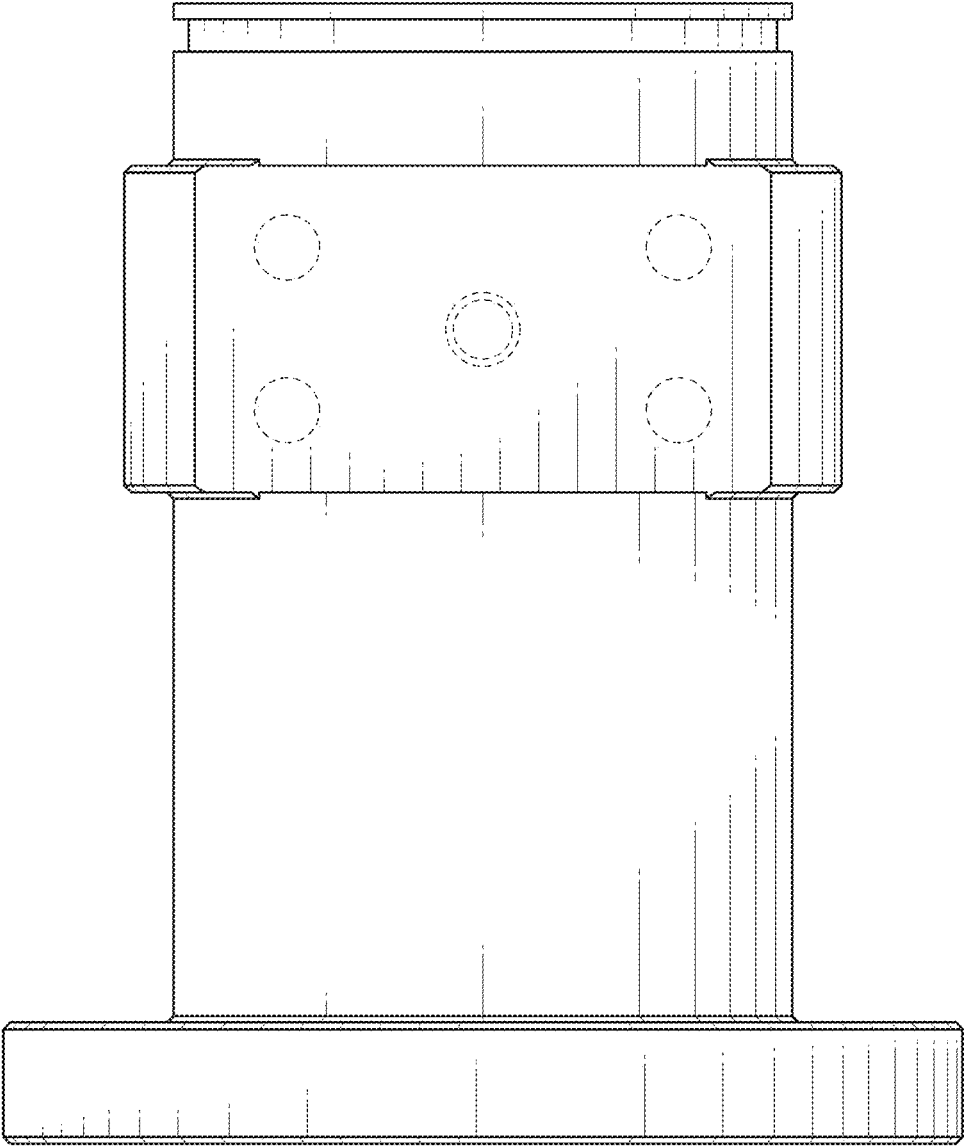

FIG. 4

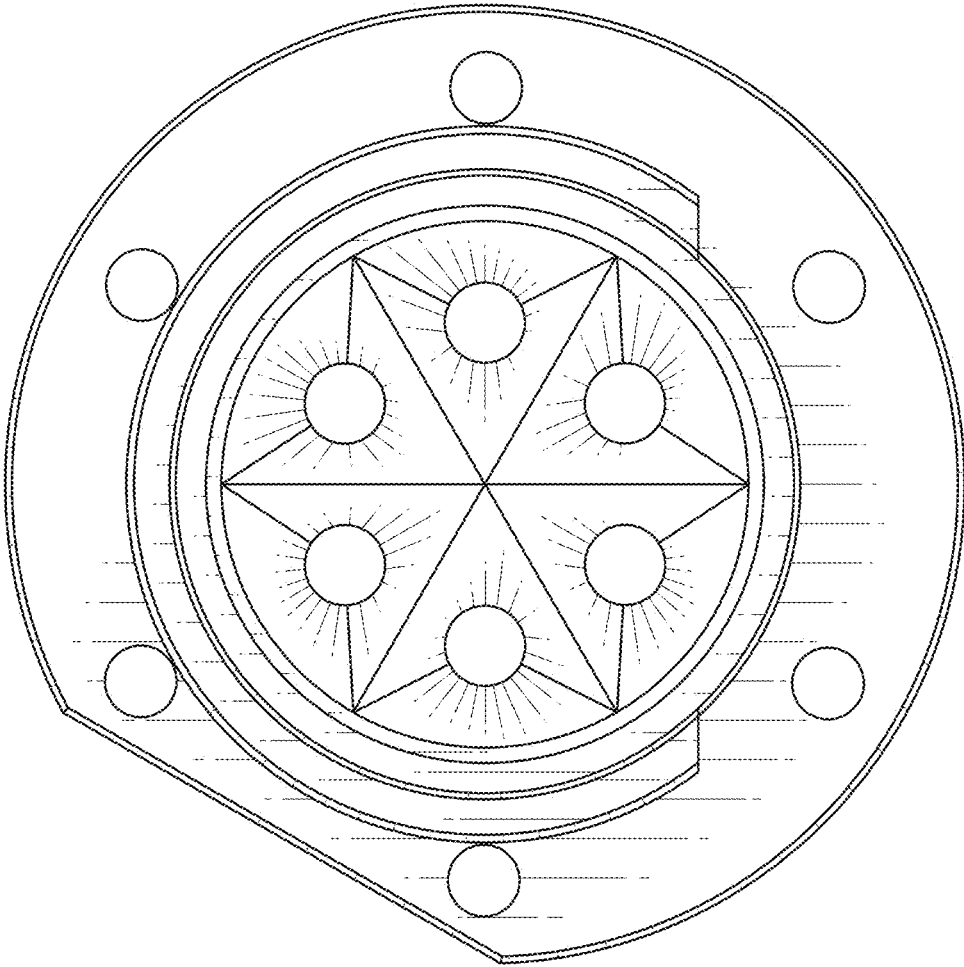

FIG. 5

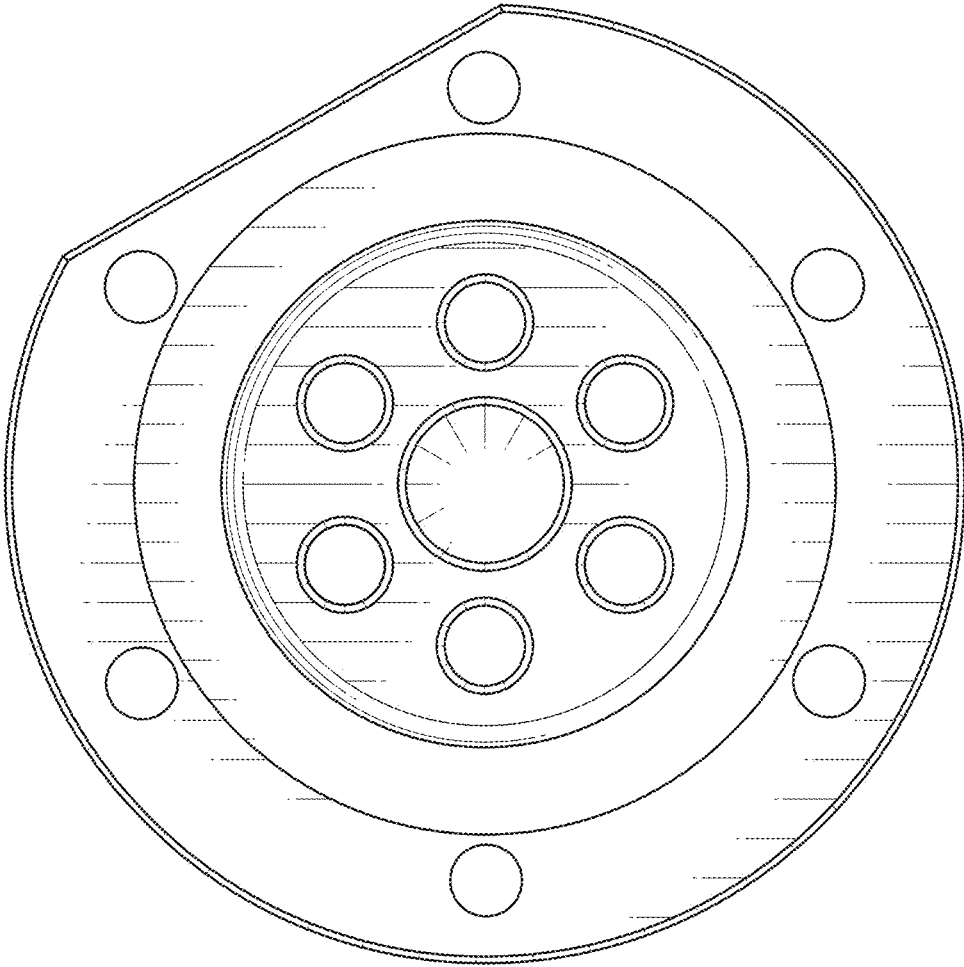

FIG. 6

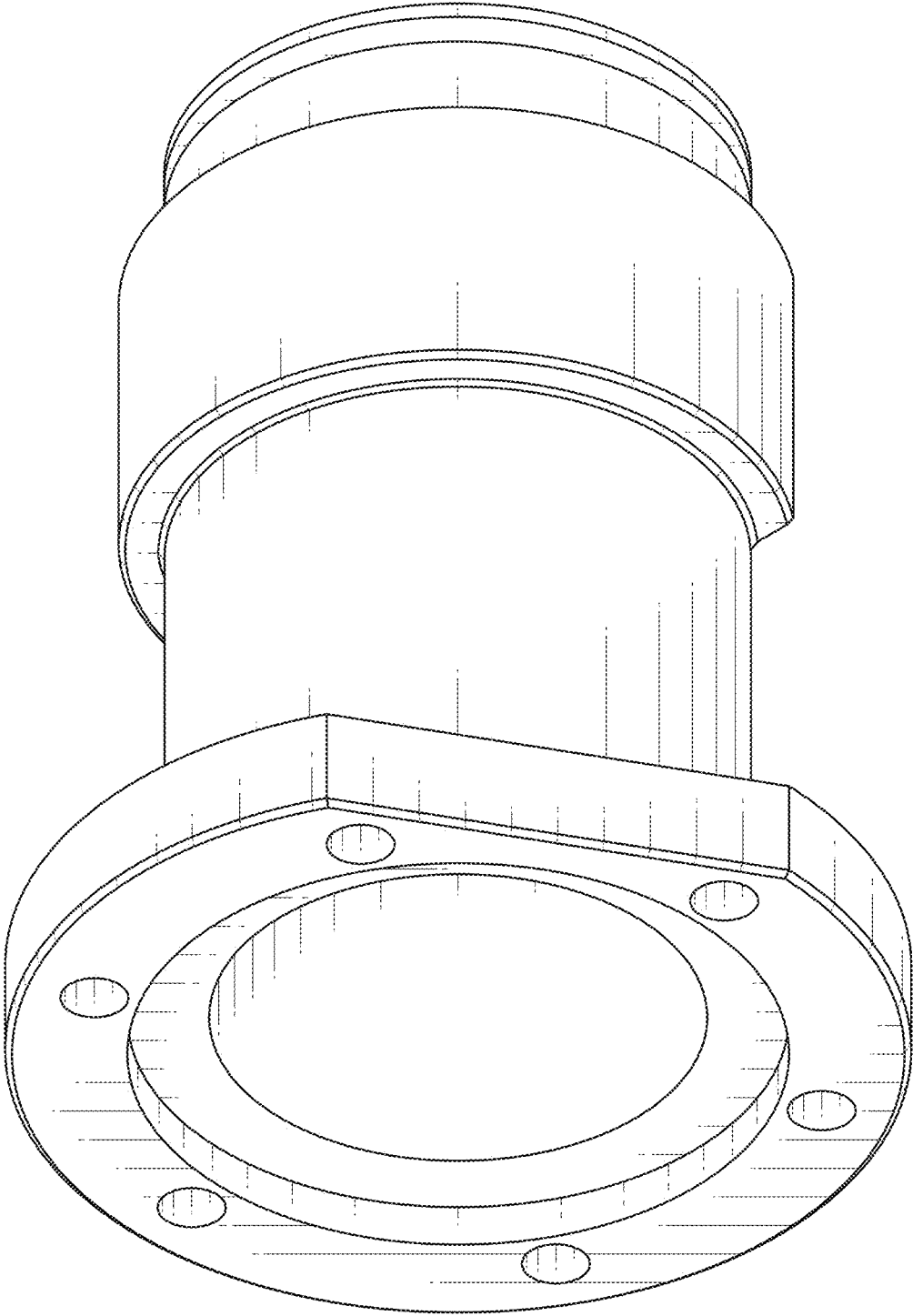

FIG. 7

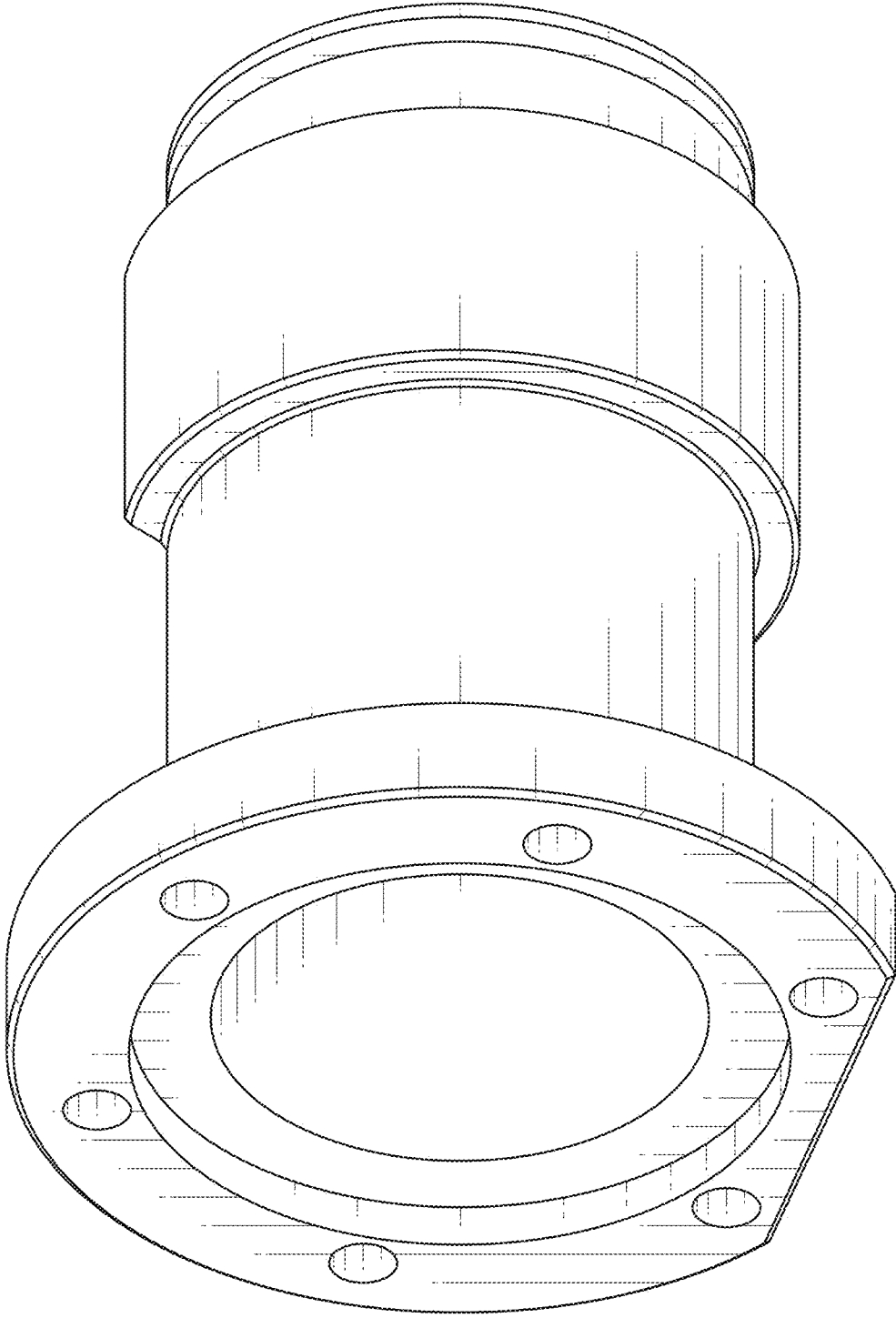

FIG. 8

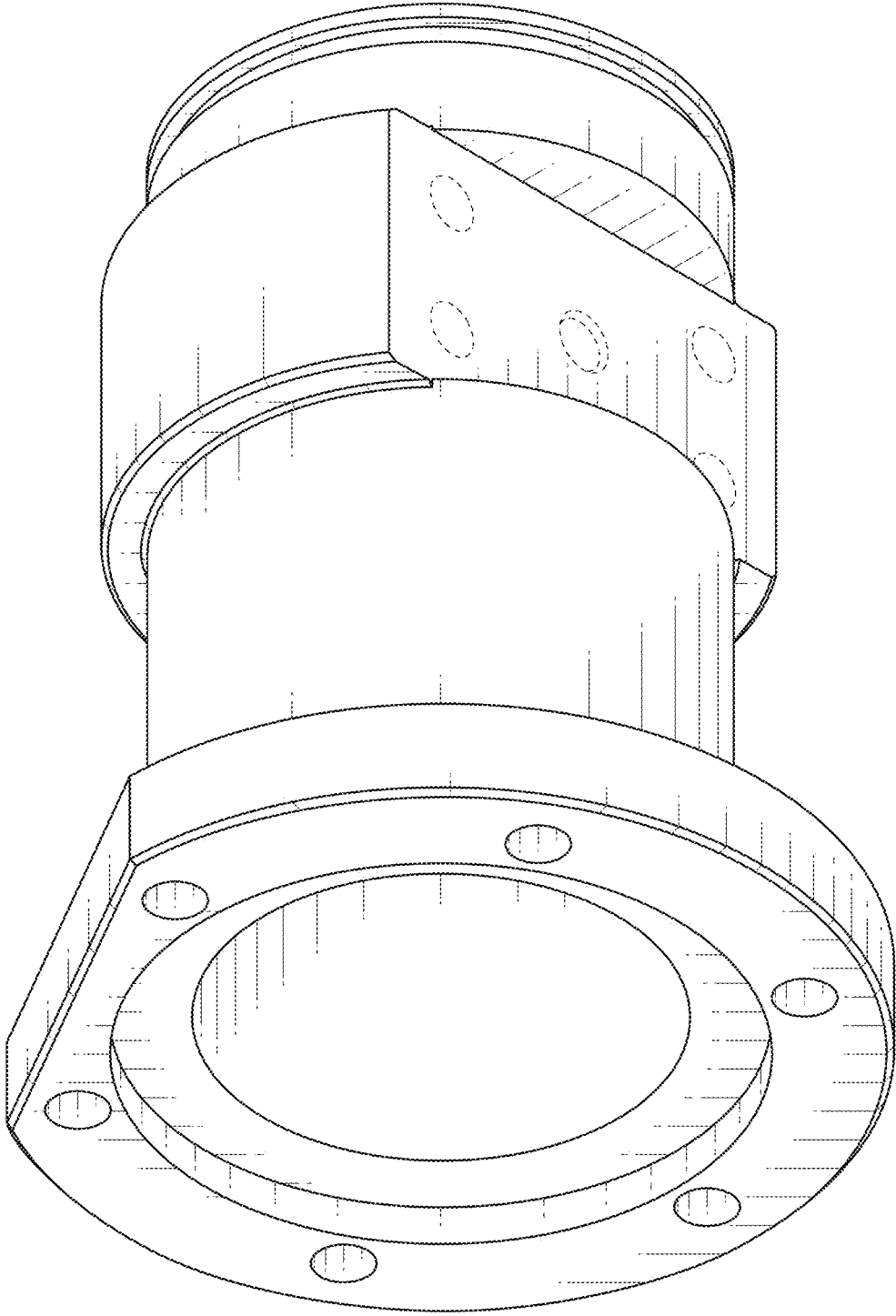

FIG. 9

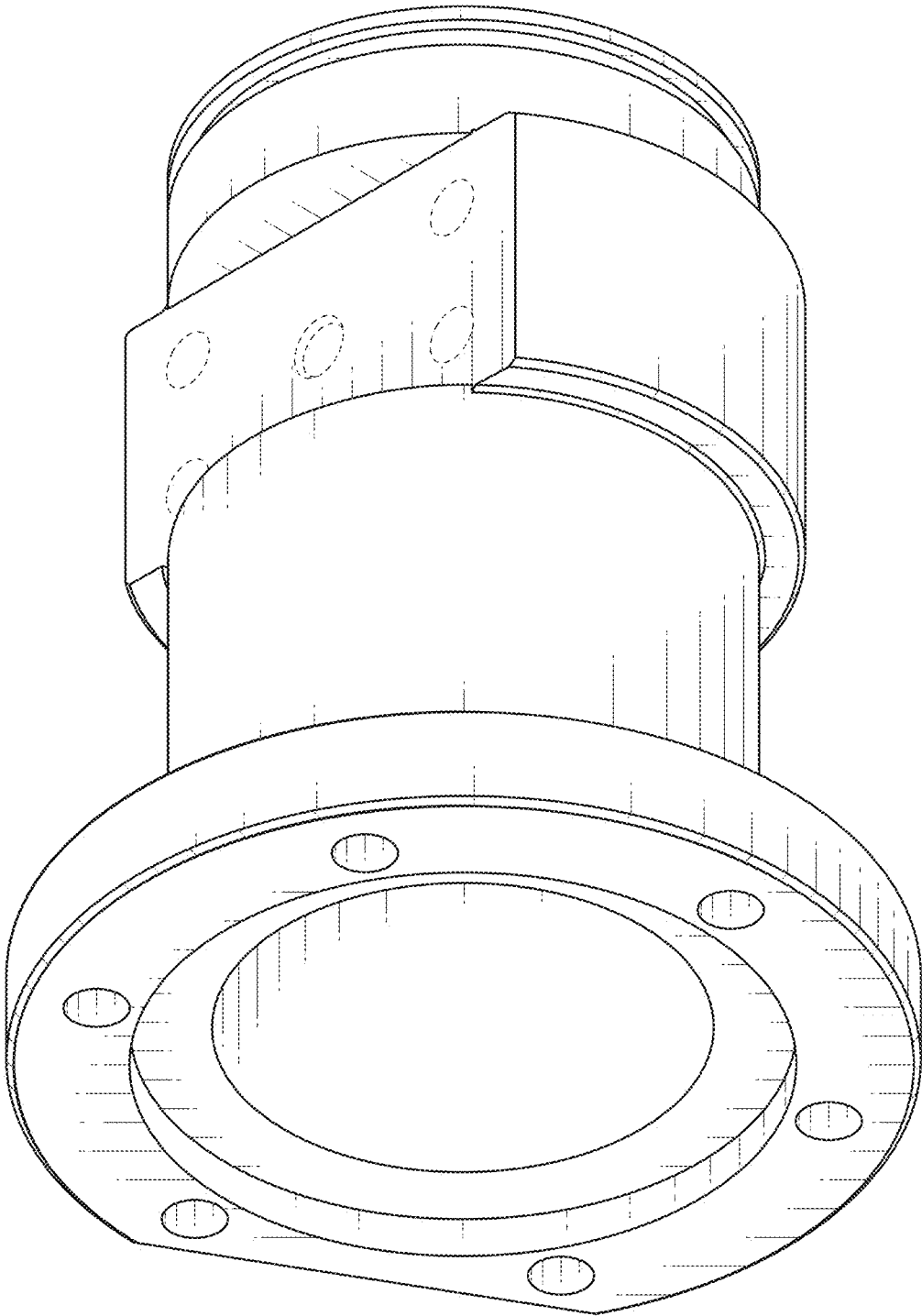

FIG. 10

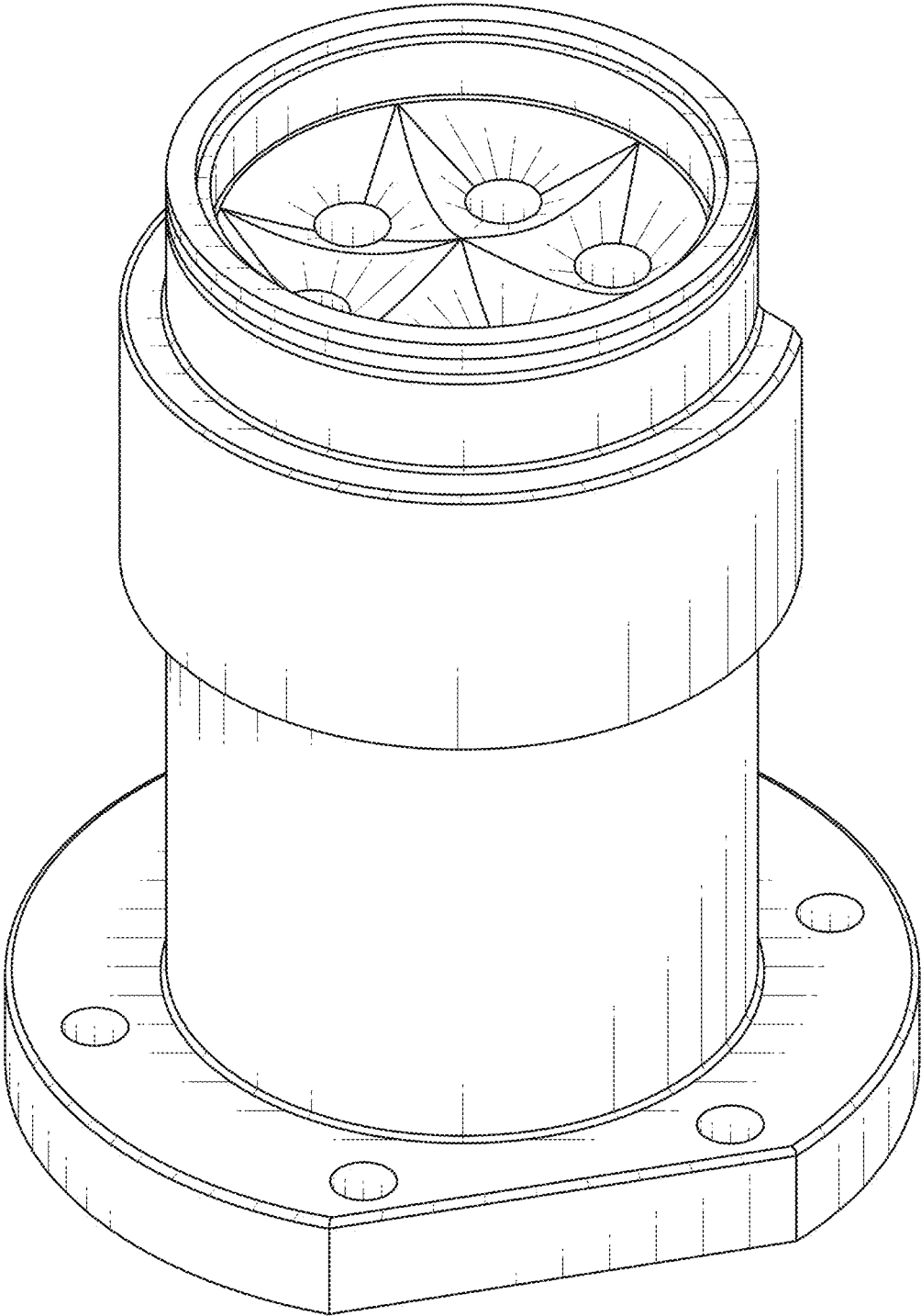

FIG. 11

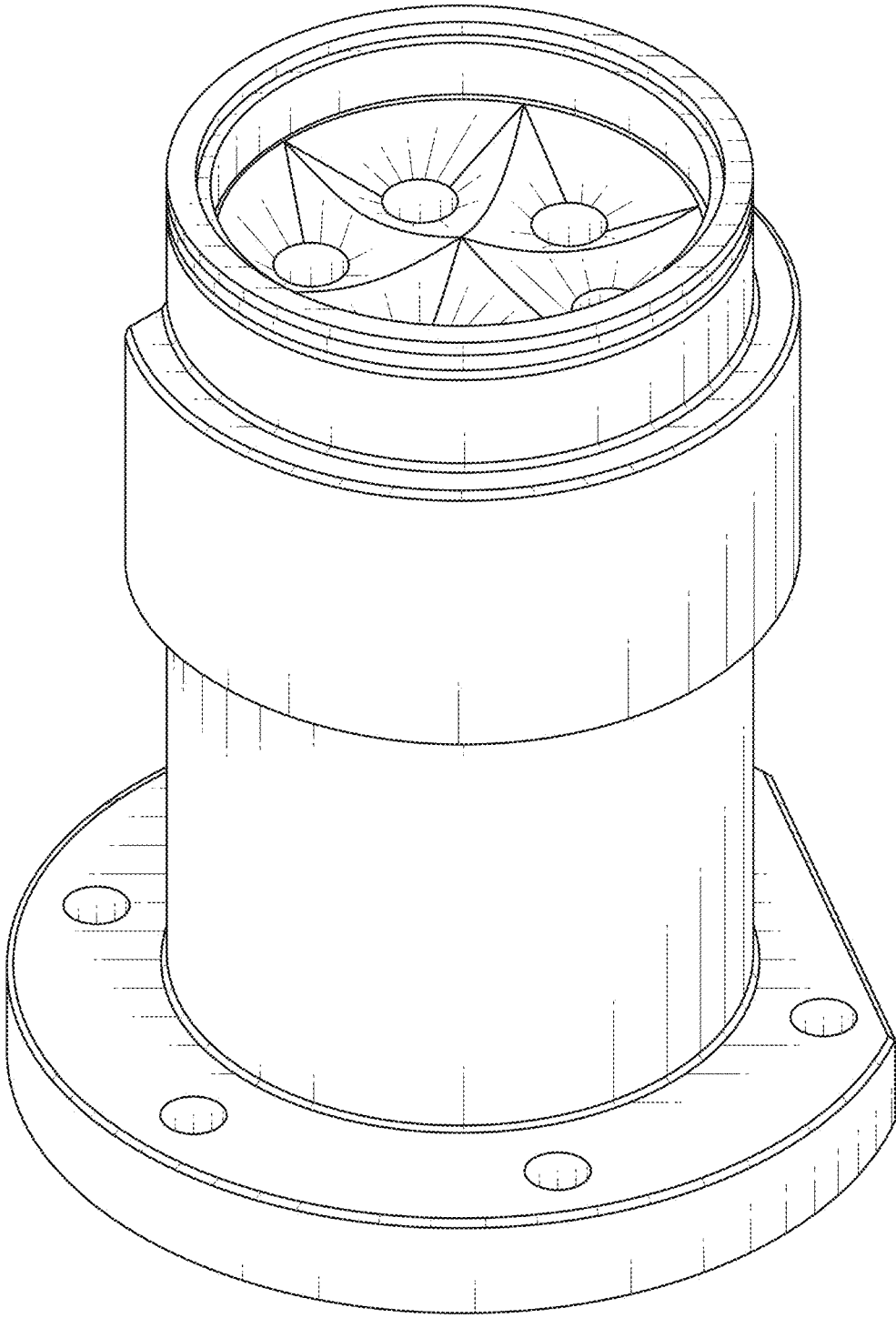

FIG. 12

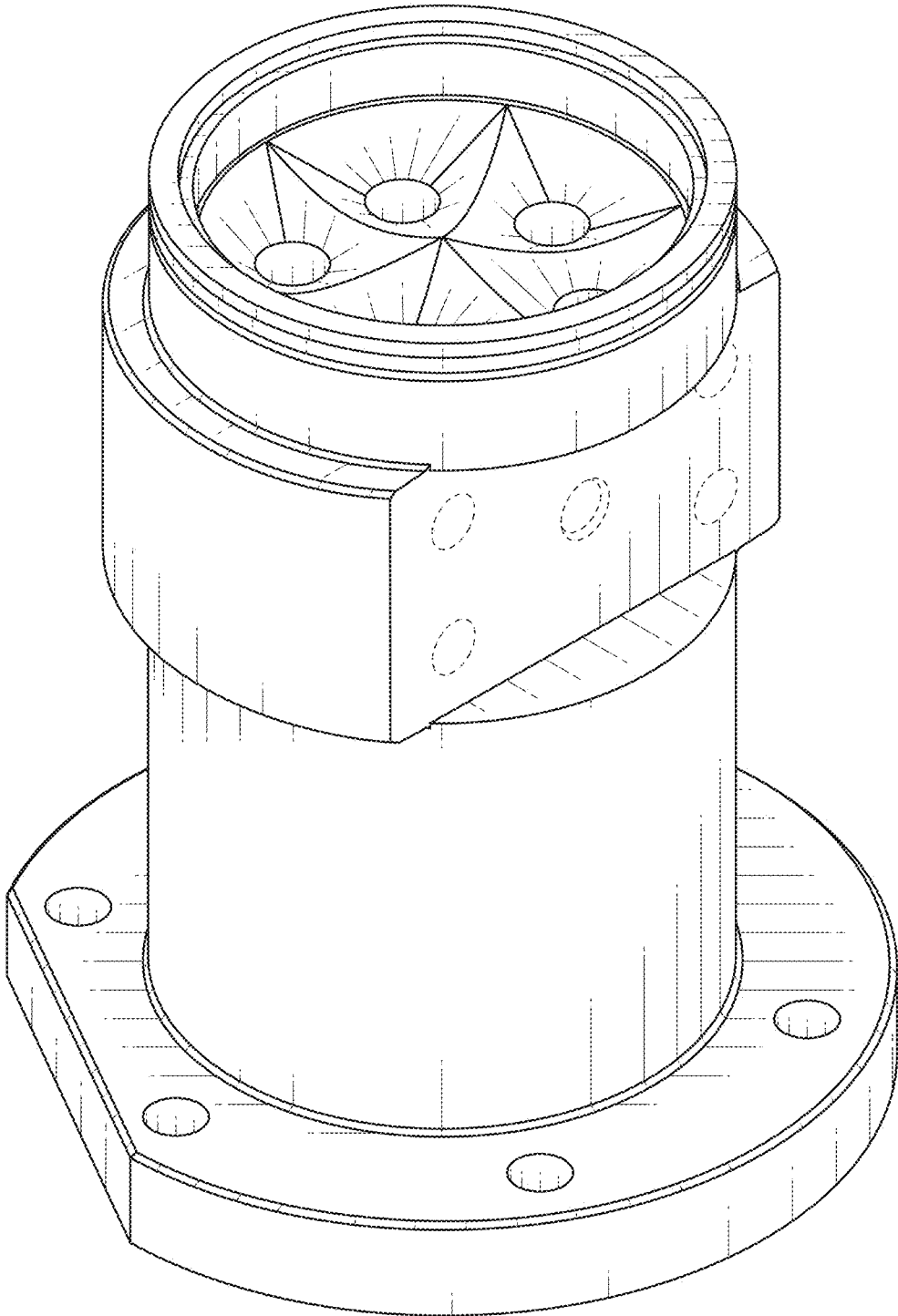

FIG. 13

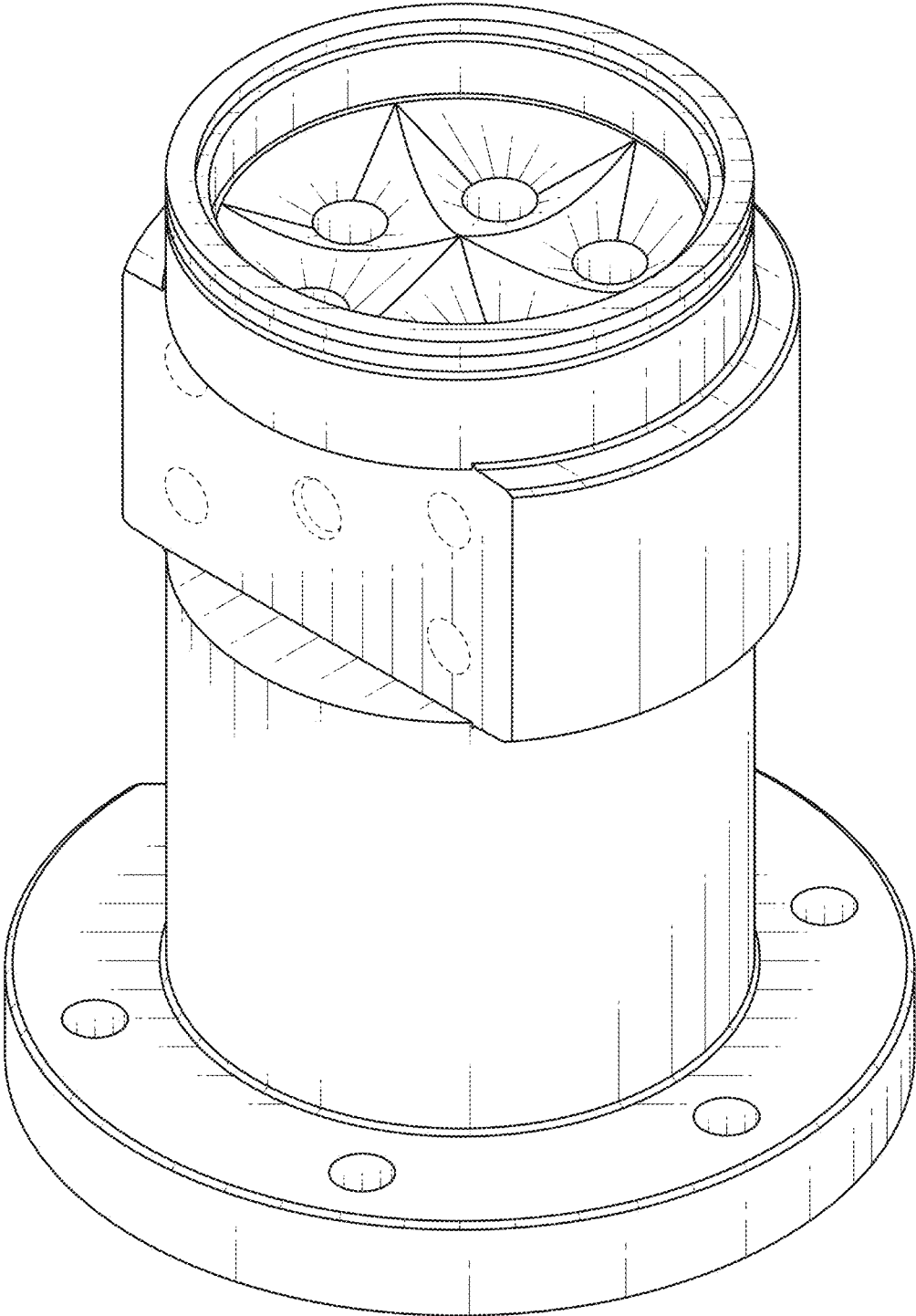

FIG. 14

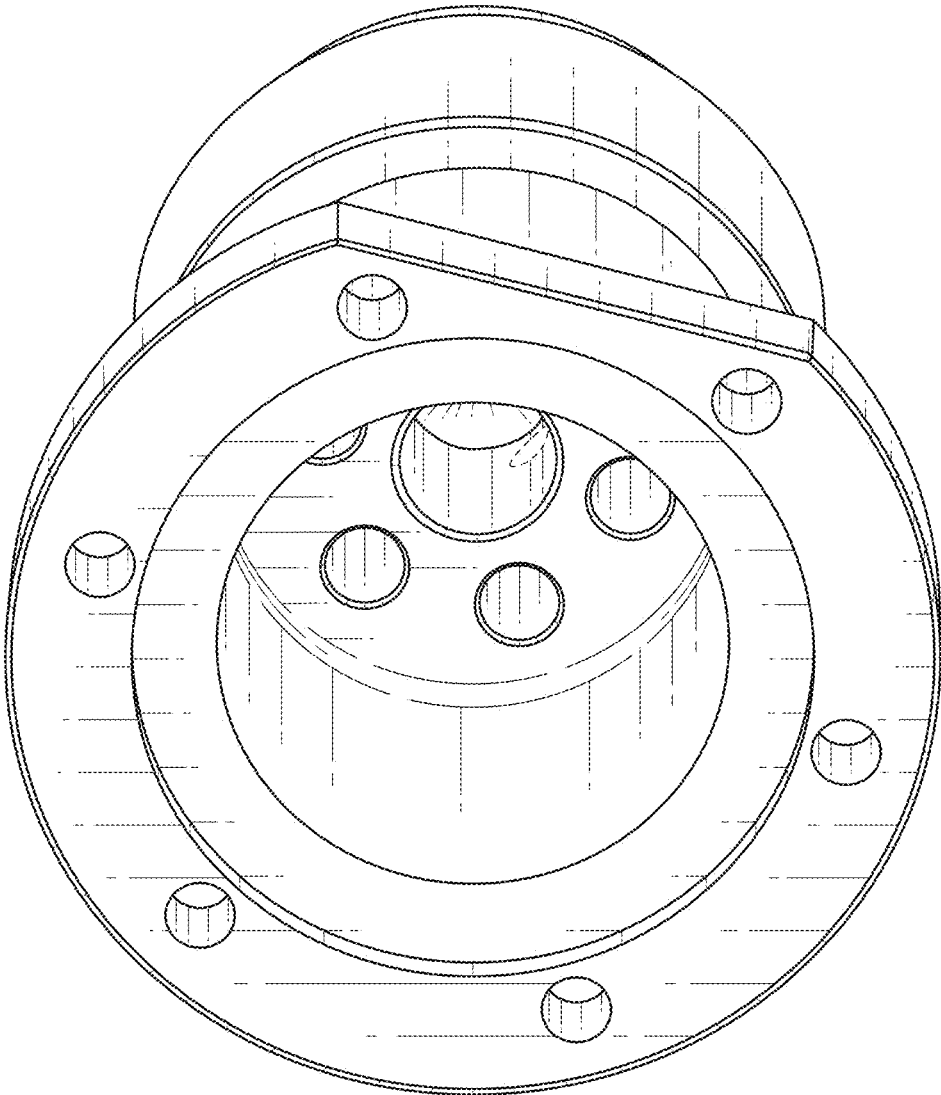

FIG. 15

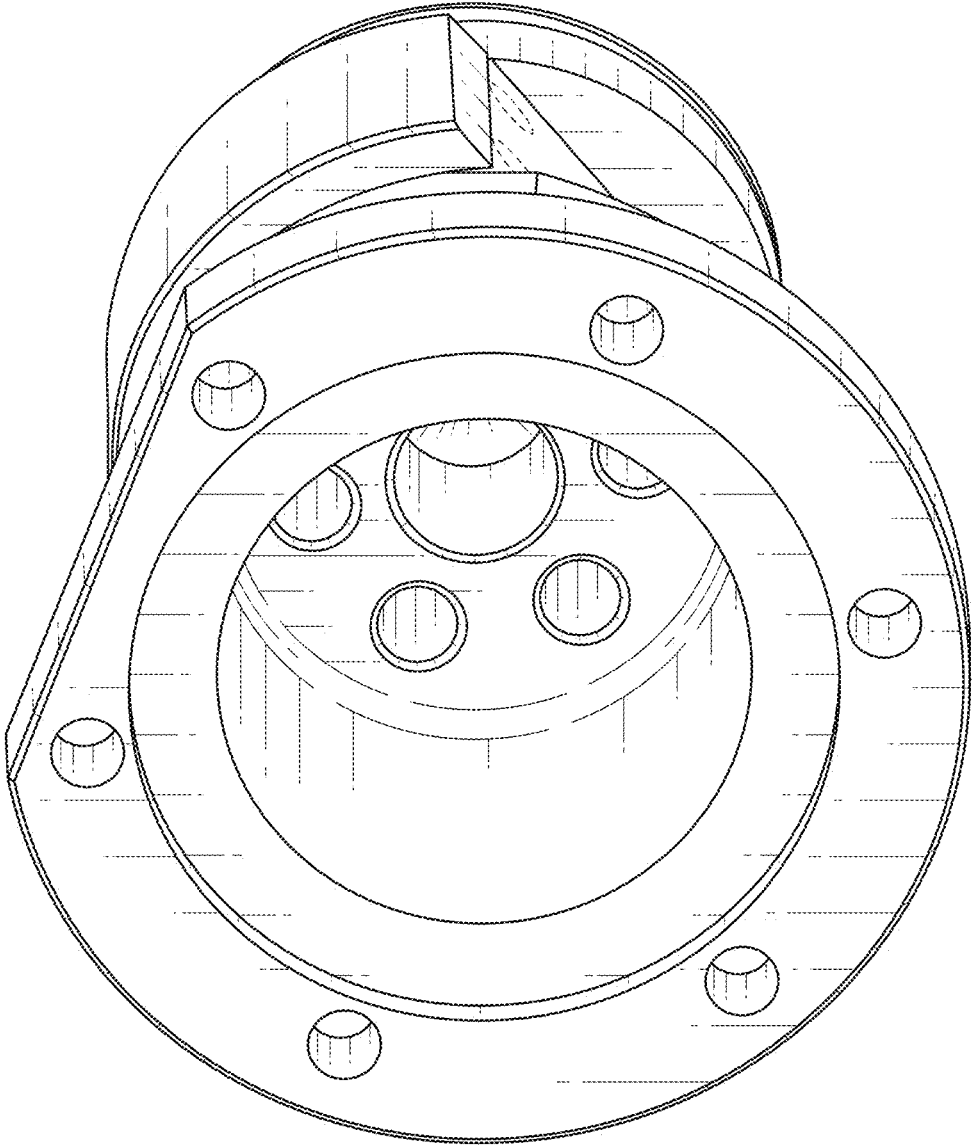

FIG. 16

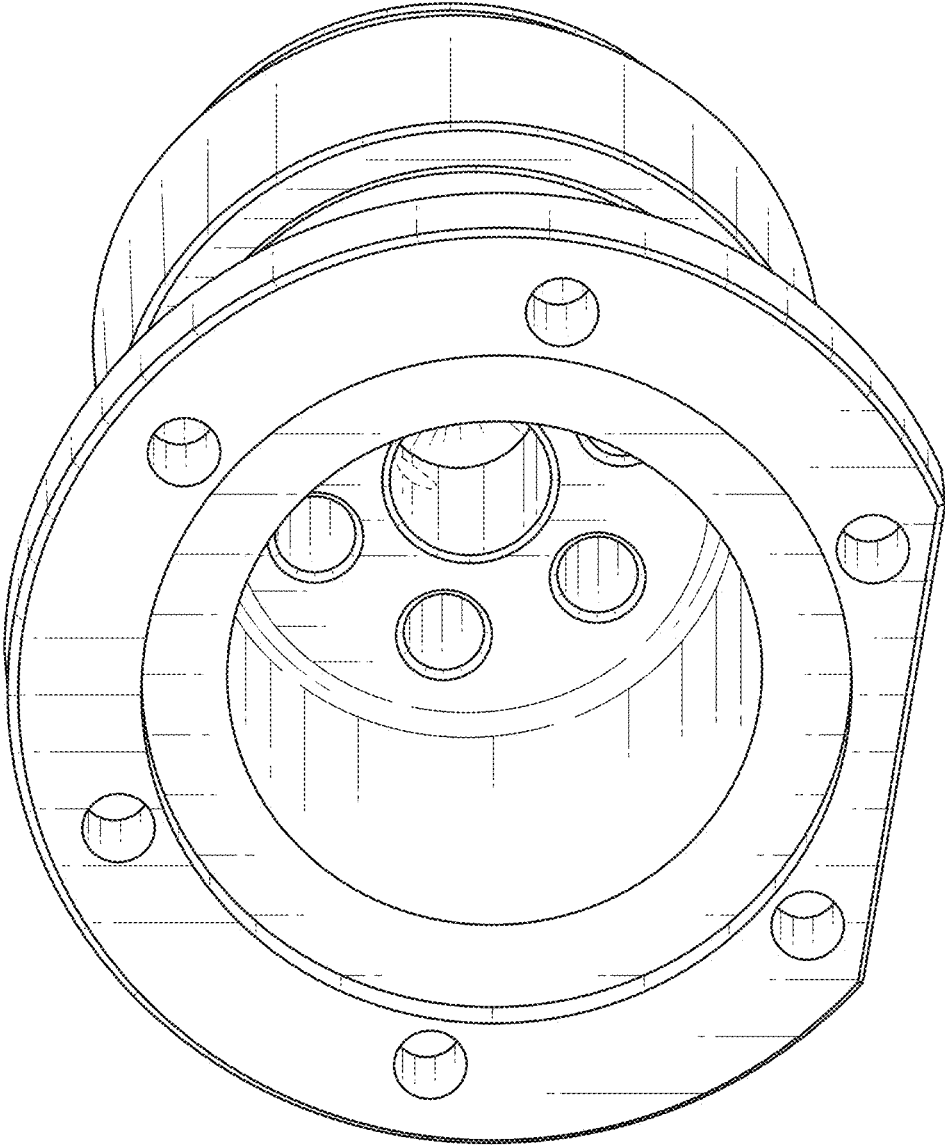

FIG. 17

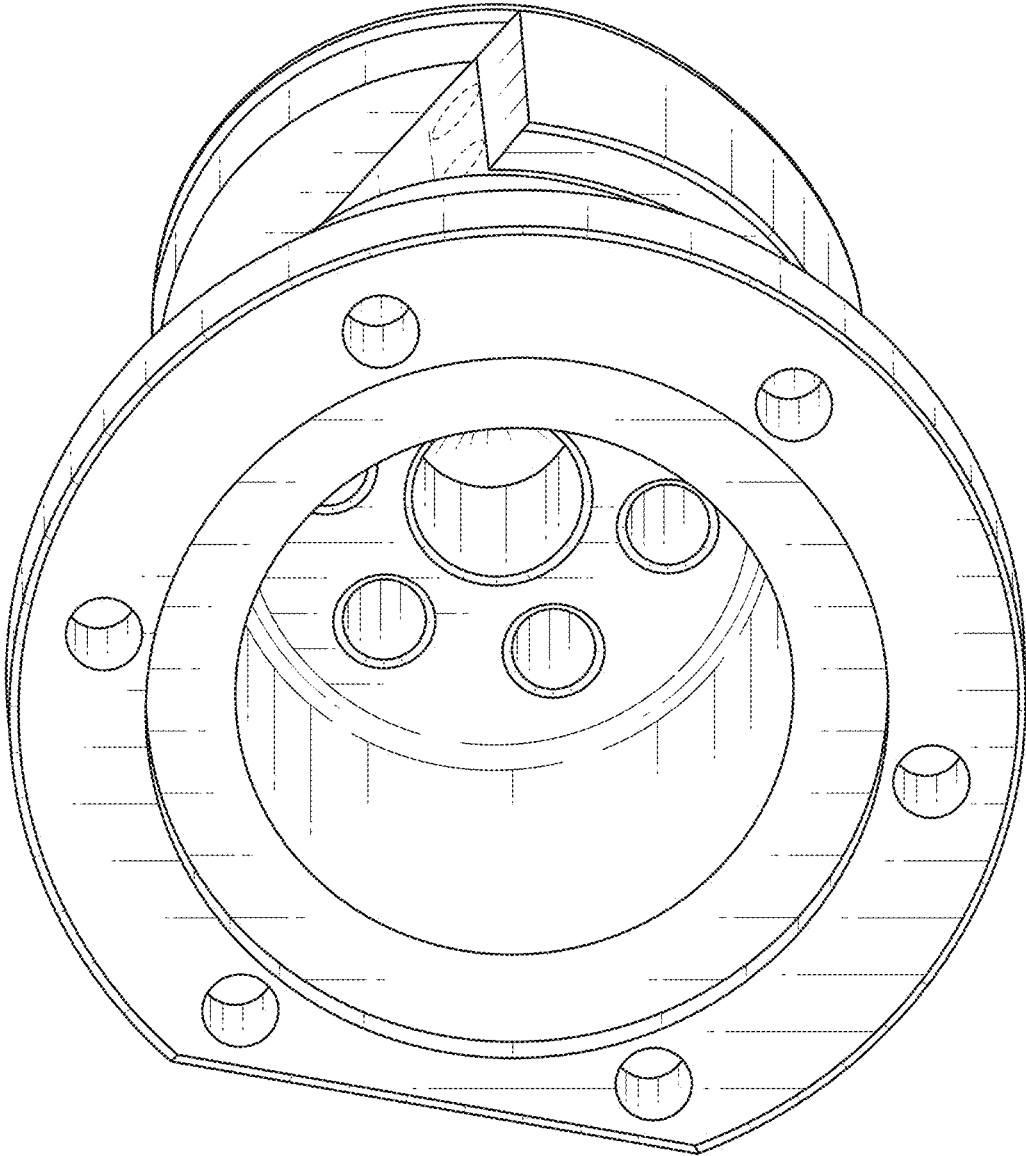

FIG. 18