

(19) **DANMARK**

(10) **DK/EP 3499109 T3**



(12) **Oversættelse af
europæisk patentskrift**

Patent- og
Varemærkestyrelsen

-
- (51) Int.Cl.: **F 21 S 10/02 (2006.01)** **F 21 V 23/00 (2015.01)** **F 21 Y 105/10 (2016.01)**
F 21 Y 115/10 (2016.01)
- (45) Oversættelsen bekendtgjort den: **2022-01-31**
- (80) Dato for Den Europæiske Patentmyndigheds bekendtgørelse om meddelelse af patentet: **2021-10-27**
- (86) Europæisk ansøgning nr.: **17838569.6**
- (86) Europæisk indleveringsdag: **2017-07-27**
- (87) Den europæiske ansøgnings publiceringsdag: **2019-06-19**
- (86) International ansøgning nr.: **CN2017094648**
- (87) Internationalt publikationsnr.: **WO2018028439**
- (30) Prioritet: **2016-08-09 CN 201620856516 U**
- (84) Designerede stater: **AL AT BE BG CH CY CZ DE DK EE ES FI FR GB GR HR HU IE IS IT LI LT LU LV MC MK MT NL NO PL PT RO RS SE SI SK SM TR**
- (73) Patenthaver: **Vertex Lighting And Electrical Co., Ltd., No.702, Blk. 15th, Shunde Wanyang Zhongchuang Park , Xiantang Vil., 1st West Rd. , Longjiang Town, Shunde District, Foshan City, Guangdong Province, Kina**
- (72) Opfinder: **WU, Liangju, No.15 Street 1 Xinyuan Road, Jili Industrial Zone, Nanzhuang Town, Foshan, Guangdong 528000, Kina**
- (74) Fuldmægtig i Danmark: **Zacco Denmark A/S, Arne Jacobsens Allé 15, 2300 København S, Danmark**
- (54) Benævnelse: **Lyskildemodul og lampe med samme**
- (56) Fremdragne publikationer:
WO-A1-2009/109387
WO-A1-2016/026153
CN-A- 102 128 396
CN-A- 104 507 197
CN-A- 105 698 119
CN-U- 201 916 746
CN-U- 202 302 925
CN-U- 205 137 334
CN-U- 205 878 043
JP-A- 2007 299 590
JP-A- 2013 004 398

DESCRIPTION

BACKGROUND OF THE PRESENT INVENTION

FIELD OF INVENTION

[0001] The present invention relates to a light source module and a lamp with light source module, which emit light source of various colors in an adjustable manner and white lights of various color temperature in an adjustable manner, so as to enhance its diversity and utility.

DESCRIPTION OF RELATED ARTS

[0002] LED has been widely utilized in our daily lives since it is energy efficient and is able to provide lights in various colors. Unfortunately, there are problems for the LED light sources currently available in the market, which include the following. From the perspective of light source, a conventional light source module only has LED chips of the three primary colors. Even though the user may adjust the parameters of the output voltage or current of the power supply to obtain mixed lights of the various proportions of the lights from the red, blue, and green LED chips, in order to achieve a light effect of colors. Nevertheless, such combination light source still has a lot of utilization deficiencies, such as low light efficacy, dissimilar light colors (larger deviations between the light colors emitted from different light sources), and etc.. Therefore, it limits the utilizing of LED light source in scenes like decorative lighting, landscape lighting, and atmosphere lighting only, rather than our daily white light illumination scenes, such as reading, dining, meeting, working, and etc.. Even though there is also dual-color temperature COB light source, it only provide two modes, the cool and warm white lights, which is not enough to satisfy the demands of colors. COB light source module of RGBW four light color output that combine the two has certain drawbacks as well. This type of light source module has LED chips of three primary colors and single white light (which color temperature is 6000K or more). It may achieve mixed white light color through adjusting the parameters of the output voltage and current of the driving power to change the proportion of the luminous intensity of the LED red-green-blue chips and white light chips. Nonetheless, such mixed white light cannot have cool/warm white light with highly consistent light color or natural appearance. Accordingly, this type of LED light source can barely provide ideal white light with adjustable color temperature to satisfy diverse white light illumination scenes.

[0003] To analyze from the perspective of packaging technology, it is difficult to produce a RGBW light source module in a four way common anode or common cathode structure, which refers to that the chip set of each light color has two bonding wire pins of the anode and the cathode respectively and, hence, the RGBW light source module contains a total of eight bonding wire pins. Such manner will cause long processing in soldering wires in the lamp

assembling process, which can affect the production efficiency of the lamp to a certain extent. Currently, it mainly utilizes reflow soldering technology to solder and attach the discrete parts of LED of the various single colors onto the aluminum PCB, so as to produce a SMD light source module. However, such manufacturing process is too complicated. The production cost is high. Moreover, the size of the SMD light source module is relatively large, so that the size of the lamp has to be correspondingly increased. In addition, because the structure of every discrete parts of LED has to respectively contain a sub-lens, when it conducts secondary light distribution for the multiple luminous points, especially secondary light distribution for the key illumination lamp, it will render optical property defects, such as double image, unnatural light spot transition, layers of different light colors, and etc.. WO 2009/109.387 discloses a light source module.

SUMMARY OF THE PRESENT INVENTION

[0004] An object of the present invention is to provide a light source module and lamp with same, wherein the light source module is capable of performing light of various mixed colors and white light of adjustable color temperature, so as to satisfy demands of diverse scenes.

[0005] Another object of the present invention is to provide a light source module and lamp with same, wherein a three-primary-color light source and a set of color temperature adjustable light sources of the light source module are respectively symmetrically arranged on a substrate, wherein a circuit component controls the three-primary-color light source and the color temperature adjustable light sources to emit various lights in a combination manner.

[0006] Another object of the present invention is to provide a light source module and lamp with same, wherein the three-primary-color light source and the color temperature adjustable light source share the same anode, wherein the three-primary-color light source and the color temperature adjustable light source respectively have different cathodes, such that the three-primary-color light source and the color temperature adjustable light source can provide and change color temperature respectively based on the strengths of the voltage or current.

[0007] Another object of the present invention is to provide a light source module and lamp with same, wherein the color temperature adjustable light source comprises a first color temperature illuminant and a second color temperature illuminant, wherein the first color temperature illuminant and/or the second color temperature illuminant may optionally be matched with the three-primary-color light source and mounted on the substrate.

[0008] Another object of the present invention is to provide a light source module and lamp with same, wherein the first color temperature illuminants of the light source module are respectively symmetrically arranged on the two sides of the three-primary-color light source, so as to allow the three-primary-color light source and the first color temperature illuminants to emit light beams of various colors in a combination manner.

[0009] Another object of the present invention is to provide a light source module and lamp with same, wherein the second color temperature illuminants of the light source module are respectively symmetrically arranged on the two sides of the three-primary-color light source, so as to allow the three-primary-color light source and the second color temperature illuminants to emit light beams of various colors in a combination manner.

[0010] Another object of the present invention is to provide a light source module and lamp with same, wherein the three-primary-color light source, the first color temperature illuminants, and the second color temperature illuminants are respectively symmetrically arranged in the central area of the substrate, wherein the first color temperature illuminants are arranged on the outer side of the three-primary-color light source, wherein the first color temperature illuminants are also located between the three-primary-color light source and the second color temperature illuminants.

[0011] Another object of the present invention is to provide a light source module and lamp with same, wherein the three-primary-color light source, the first color temperature illuminants, and the second color temperature illuminants are respectively symmetrically arranged on the substrate, wherein the second color temperature illuminants are arranged on the outer side of the three-primary-color light source, wherein the second color temperature illuminants are also located between the three-primary-color light source and the first color temperature illuminants.

[0012] Another object of the present invention is to provide a light source module and lamp with same, wherein the first color temperature illuminant and/or the second color temperature illuminant are respectively arranged on the substrate concentrically to the center of the three-primary-color light source, so as to respectively become a periphery of the three-primary-color light source.

[0013] Another object of the present invention is to provide a light source module and lamp with same, wherein the three-primary-color light source, the first color temperature illuminants, and the second color temperature illuminants share the same anode, wherein the three-primary-color light source, the first color temperature illuminants, and the second color temperature illuminants respectively have different cathodes, such that the three-primary-color light source, the first color temperature illuminants, and the second color temperature illuminants can provide and change color temperature respectively based on the strengths of the voltage or current.

[0014] Another object of the present invention is to provide a light source module and lamp with same, wherein the three-primary-color light source comprises a set of first chips and a first cover layer, wherein the first chips are longitudinally arranged and aligned along an A axis on the substrate, so as for adjustably emitting various three-primary-color lights.

[0015] Another object of the present invention is to provide a light source module and lamp with same, wherein the first color temperature illuminant comprises a set of second chips and a

second cover layer, wherein the second chips are longitudinally arranged and aligned along the A axis, wherein the second cover layer covers the second chips, so as to allow the second chips to generate adjustable cool white light.

[0016] Another object of the present invention is to provide a light source module and lamp with same, wherein the second color temperature illuminants comprises a set of third chips and a third cover layer, wherein the third chips are longitudinally arranged and aligned along the A axis, wherein the third cover layer covers the third chips, so as to allow the third chips to generate adjustable warm white light.

[0017] Another object of the present invention is to provide a light source module and lamp with same, wherein the light-emitting sources share a lens, so as for achieving a secondary light distribution design and providing a spotlighting effect in a certain light angle.

[0018] Another object of the present invention is to provide a light source module and lamp with same, wherein the light-emitting sources are symmetrically arranged on the substrate based on a predetermined rule, so as to achieve a compact structure.

[0019] Another object of the present invention is to provide a light source module and lamp with same, wherein the light source module made through chip level packaging chip on board (COB) technology is advantageous in small size, so as to allow the light source module to have a compact structure.

[0020] Another object of the present invention is to provide a light source module and lamp with same, wherein the light source module is a COB light source module manufactured by LED packaging manufacturer, which reduces producing steps and saves production costs.

[0021] Another object of the present invention is to provide a light source module and lamp with same, wherein the lamp comprises a shell and a connecting member, wherein the shell further comprises a base, a housing, and a face cover, wherein the base, the housing, and the face cover are detachably connected through the connecting member respectively.

[0022] Another object of the present invention is to provide a light source module and lamp with same, wherein the light source module is detachably arranged in an accommodating chamber of the base through a heat dissipation member, wherein a lens is also arranged on the light source module.

[0023] A technical solution of the present invention that achieves at least is provided by light source module according to independent claim 1. The dependent claims relate to advantageous embodiments.

BRIEF DESCRIPTION OF THE DRAWINGS

[0024]

Figs. 1A and 1B illustrate positional relations of the three-primary-color light source and the first color temperature illuminants arranged on the substrate according to a first embodiment of the present invention.

Figs. 2A and 2B illustrate positional relations of the three-primary-color light source and the second color temperature illuminants arranged on the substrate according to a second embodiment of the present invention.

Figs. 3A and 3B illustrate positional relations of the three-primary-color light source, the first color temperature illuminants, and the second color temperature illuminants arranged on the substrate according to a third embodiment of the present invention.

Figs. 4A and 4B illustrate positional relations of the three-primary-color light source, the first color temperature illuminants, and the second color temperature illuminants arranged on the substrate according to a fourth embodiment of the present invention.

Figs. 5A and 5B illustrate positional relations of the three-primary-color light source, the first color temperature illuminants, and the second color temperature illuminants arranged on the substrate according to an embodiment not covered by claim 1 and according to a fifth embodiment of the present invention respectively.

FIG. 6 is a circuit schematic illustrating the first chips, the second chips, and the third chips arranged on the substrate according to the present invention.

Fig. 7 is a perspective view of a lamp with light source module according to the present invention.

Fig. 8 is an exploded view of a lamp with light source module according to the present invention.

DETAILED DESCRIPTION OF THE PREFERRED EMBODIMENT

[0025] The following description is disclosed to enable any person skilled in the art to make and use the present invention. Preferred embodiments are provided in the following description only as examples and modifications will be apparent to those skilled in the art. The general principles defined in the following description would be applied to other embodiments, alternatives, modifications, equivalents, and applications without departing from the scope of the present invention.

[0026] Referring to Figs. 1A-4B, a light source module 1 of the present invention is capable of providing lights of various adjustable colors and white lights in various adjustable color temperature. Therefore, the light source module 1 may be widely utilized in different daily

circumstances, while conventional light source module can be much limited in use. The light source module 1 comprises a substrate 10 and a light source assembly 20 arranged in a central area on a mounting side of the substrate 10. The substrate 10 provides a mounting surface for the light source module 1. The substrate 10 is a sheet structure made of aluminum or ceramics.

[0027] The light source assembly 20 comprises a light-emitting source 21 and a circuit component 22. The light-emitting source 21 and the circuit component 22 are respectively arranged on the mounting side of the substrate 10. The light-emitting source 21 is electrically connected with an external power supply through the circuit component 22, such that the light-emitting source 21 can generate light when powered on. The light source module 1 may produce different light combination based on the needs of the user. It emits various types of color light beams by combining different proportions of brightness of the three primary color lights or high luminous efficient white lights with various color temperatures by combining different proportions of brightness of cool and/or warm white lights. It is worth mentioning that the light-emitting source 21 further comprises a three-primary-color light source 211 and at least a color temperature adjustable light source 212, wherein the three-primary-color light source 211 and the color temperature adjustable light source 212 are respectively arranged on the substrate 10, wherein the three-primary-color light source 211 and the color temperature adjustable light source 212 are respectively electrically connected with the circuit component 22. Besides, an external power supply is electrically connected with the circuit component 22, so as to power on the three-primary-color light source 211 and the color temperature adjustable light source 212. Lights emitted by the three-primary-color light source 211 and the color temperature adjustable light source 212 may have various colors in a selective combination manner, so as for satisfying diverse demands. Here, the three-primary-color light source 211 is a chip with three primary color wave bands. The light source of three primary color wave bands, based on the understanding of person skilled in the art, refers to that the three-primary-color light source 211 is capable of emitting red light, blue light, and green light. In actual use, the light source of three primary color wave bands utilizes the three primary colors as a basis and selects different brightness proportionally to be mixed or combined into various colors. In other words, the three-primary-color light source 211 may, based on the actual needs of the user, be freely adjusted and changed to produce light beams of various colors, so as to satisfy the needs of the utilization.

[0028] Here, the color temperature adjustable light source 212 comprises a set of first color temperature illuminants 2121 and a set of second color temperature illuminants 2122. The first color temperature illuminants 2121 being powered on may generate cool white light, while the second color temperature illuminants 2122 being powered on may generate warm white light. Also, the first color temperature illuminants 2121 and the second color temperature illuminants 2122 emit high luminous efficient white lights with various color temperatures by combining different proportions of brightness of white lights, so as to satisfy the needs of various circumstances. Contrasting to conventional light source module, the light source module 1 can selectively adjust the proportion of the combination of the three-primary-color light sources and/or the cool/warm white lights, so as to provide an enhanced utility. Light source module

currently available in the market can only utilize either the three-primary-color light source or the color temperature adjustable light source. Even if both of the light sources are utilized at the same time, the mixed white light fails to be natural or present cool/warm white light with highly consistent light color. Accordingly, such kind of light source can barely provide ideal white light with adjustable color temperature to satisfy diverse white light illumination scenes.

[0029] It is worth mentioning that the three-primary-color light source 211 comprises a set of first chips 2111 and a first cover layer 2112. The first chips 2111 are arranged in the central area of the substrate 10 and longitudinally aligned along a A axis in a regular manner, wherein the red light chips, the blue light chips, and the green light chips are respectively arranged based on a certain rule. Here, to be along the A axis may be considered the y-axis direction, while to be perpendicular to the A axis may be considered the x-axis direction. The red light chips, the blue light chips, and the green light chips are respectively, successively, and longitudinally arranged along the A axis. For each row in the x-axis direction, the red light chips, the blue light chips, and the green light chip are arranged and aligned in accordance with a certain predetermined space. The first cover layer 2112 is correspondingly longitudinally arranged along the A axis to cover the surface of the first chips 2111. The first cover layer 2112 is a clear colloid, which material is a transparent colloid, such as silicone or epoxy resin. The first chips 2111 covered by the first cover layer 2112 may emit three-primary-color lights.

[0030] The first color temperature illuminant 2121 comprises a set of second chips 21211 and a second cover layer 21212 covered on the second chips 21211. When the second chips 21211 are provided on the substrate 10, the second cover layer 21212 correspondingly longitudinally covers the surface of the second chips 21211 along the A axis. The second chips 21211, under the covering of the second cover layer 21212, are capable of performing as the first color temperature illuminants 2121 to produce and emit cool white color light in the color temperature of 4000K-8000K or, preferably, 4500K-7000K. The second chips 21211 are longitudinally arranged and aligned along the A axis based on a certain rule, wherein a predetermined distance is kept between each two second chips 21211. Here, the second cover layer 21212 is a colloid with ingredient of YAG phosphor.

[0031] The second color temperature illuminant 2122 comprises a set of third chips 21221 and a third cover layer 21222 correspondingly longitudinally covered on the third chips 21221 along the A axis. When the third chips 21221 are provided on the substrate 10, the surface of the third chips 21221 are covered by the third cover layer 21222. The third chips 21221, under the covering of the third cover layer 21222, are capable of performing as the second color temperature illuminants 2122 to produce and emit warm white color light in the color temperature of 1000K-4500K or, preferably, 2000K-3500K. The third chips 21221 are longitudinally arranged and aligned along the A axis based on a certain rule, wherein a predetermined distance is kept between each two third chips 21221. Here, the third cover layer 21222 is a colloid with ingredient of YAG phosphor.

[0032] It is worth mentioning that the first chip 2111 is a three primary color LED chip, the second chip 21211 is a cool white light LED chip (high efficiency InGaN/GaN based LED blue

light chip), and the third chip 21221 is a warm white light LED chip (high efficiency InGaN/GaN based LED blue light chip). The LED blue light chip being powered on can emit light to stimulate the ingredient of YAG phosphor of various proportions in the colloid of the cover layer for producing white light in various color temperatures. Here, when the second chips 21211 are powered on to emit light, the YAG phosphor in the second cover layer 21212 will be stimulated to produce cool white light in the color temperature of 4500K-7000K. Similarly, when the third chips 21221 are powered on to emit light, the YAG phosphor in the third cover layer 21222 will be stimulated to produce warm white light in the color temperature of 1000K- 4000K. The white light in the color temperature of 1000K-7000K can be emitted in a combination manner through adjusting the setting of the numerical ratio of the voltage or current of the second chips 21211 and the third chips 21221 and correspondingly through the second cover layer 21212 and the third cover layer 21222, such that the light source module 1 can achieve a white light illuminating effect with adjustable color temperature.

[0033] It is worth mentioning that the electric connection among the first chips 2111, the second chips 21211, and the third chips 21221 can be achieved through related semiconductor packaging technologies. The first chips 2111 are electrically connected with each other in series; the second chips 21211 are electrically connected with each other in series; and the third chips 21221 are electrically connected with each other in series. The first chips 2111, the second chips 21211, and the third chips 21221 are electrically connected with one another in series as well.

[0034] It is worth mentioning that there are four ways of the arrangements among the first chips 2111, the second chips 21211, and the third chips 21221. According to a first embodiment as illustrated in Figs. 1A and 1B, the first chips 2111 are arranged and aligned perpendicularly along the A axis on the substrate 10, while the second chips 21211 are respectively arranged and aligned by the two sides of the first chips 2111 and along the A axis as well. Besides, the second chips 2121 are arranged and aligned perpendicularly along the A axis. In addition, the arranging directions of the first chips 2111 and the second chips 21211 are consistent. Here the first chips 2111 and the second chips 21211 are parallel to each other. The users may, based on their needs, adjust the brightness of the first chips 2111 and the second chips 21211 in order to selectively generate light beams of various colors in a combination manner. Namely, the three-primary-color light source 211 and the first color temperature illuminants 2121 may produce light source of various colors in a combination manner.

[0035] According to a second embodiment as illustrated in Figs. 2A and 2B, the first chips 2111 are arranged and aligned perpendicularly along the A axis on the substrate 10, while the third chips 21221 are respectively arranged and aligned by the two sides of the first chips 2111 and along the A axis as well. Besides, the third chips 21221 are arranged and aligned perpendicularly along the A axis. In addition, the arranging directions of the first chips 2111 and the third chips 21221 are consistent. Here the first chips 2111 and the third chips 21221 are parallel to each other. The users may, based on their needs, adjust the brightness of the first chips 2111 and the third chips 21221 in order to selectively generate light beams of various

colors in a combination manner. Namely, the three-primary-color light source 211 and the second color temperature illuminants 2122 may produce light source of various colors in a combination manner.

[0036] According to a third embodiment as illustrated in Figs. 3A and 3B, the first chips 2111 are arranged and aligned perpendicularly along the A axis on the substrate 10, while the second chips 21211 are respectively arranged and aligned by the two sides of the first chips 2111 and along the A axis as well. Besides, the third chips 21221 are respectively arranged by the periphery of the second chips 21211, which can be considered that the third chips are arranged adjacent to the edge of the substrate 10. In addition, the arranging directions of the first chips 2111, the second chips 21211, and the third chips 21221 are consistent. In other words, the second chips 21211 are respectively located between the first chips 2111 and the third chips 21221. Here, the first chips 2111, the second chips 21211, and the third chips 21221 are respectively parallel to one another. The user may, based on the needs, adjust the brightness of the first chips 2111, the second chips 21211, and the third chips 21221, so as to selectively produce light beam of various colors in a combination manner. Namely, light of various colors can be generated through combining different light sources of the three-primary-color light source 211, the first color temperature illuminants 2121, and the second color temperature illuminants 2122.

[0037] It is worth mentioning that because the first chips 2111, the second chips, and the third chips 21221 are respectively longitudinally arranged into straight lines, when covering and coating corresponding clear packaging colloid on the positions of the first chips 2111, the second chips, and the third chips 21221, the glue dispensing processes can also be simplified into straight back and forth movements, which enhances the production efficiency of the light source module 1 to a certain extent.

[0038] According to a fourth embodiment as illustrated in Figs. 4A and 4B, the first chips 2111 are arranged and aligned perpendicularly along the A axis on the substrate 10, while the third chips 21221 are respectively arranged and aligned by the two sides of the first chips 2111 and along the A axis as well. Besides, the second chips 21211 are respectively arranged by the periphery of the third chips 21221, which can be considered that the third chips are arranged adjacent to the edge of the substrate 10. In addition, the arranging directions of the first chips 2111, the third chips 21221, and the third chips 21221 are consistent. In other words, the third chips 21221 are respectively located between the first chips 2111 and the second chips 21211. Here, the first chips 2111, the second chips 21211, and the third chips 21221 are respectively parallel to one another. The user may, based on the needs, adjust the brightness of the first chips 2111, the second chips 21211, and the third chips 21221, so as to selectively produce light beam of various colors in a combination manner. Namely, light of various colors can be generated through combining different light sources of the three-primary-color light source 211, the first color temperature illuminants 2121, and the second color temperature illuminants 2122.

[0039] According to an embodiment of the present disclosure not covered by claim 1 and

according to a fifth embodiment of the present invention, as illustrated in Figs. 5A and 5E respectively, the first chips 2111 are positioned in the central area of the substrate 10 and the second chips 21211 and the third chips 21221 are arranged according to the same central point of the pattern formed by the first chips 2111. Referring to Fig. 5A, the second chips 21211 and/or the third chips 21221 are respectively arranged by the periphery of the first chips 2111. Namely, the second chips 21211 are positioned by the periphery of the first chips 2111 or the third chips 21221 are positioned by the periphery of the first chips 2111 or both the second chips 21211 and the third chips 21221 are respectively positioned by the periphery of the first chips 2111. The first color temperature illuminants 2121 and/or the second color temperature illuminants 2122 are respectively positioned around the three-primary-color light source 211 in a ring-like or girdle manner. The first chips 2111 form a circular shape, while the second chips 21211 and the third chips 21221 respectively form a ring shape. Referring to Fig. 5B, the first chips 2111 form a square shape, while the second chips 21211 and the third chips 21221 respectively form a square ring-like shape.

[0040] Here, according to a third embodiment and a fourth embodiment, as illustrated in Fig. 6, the circuit components 22 are respectively electrically connected with the three-primary-color light source 211, the first color temperature illuminants 2121, and the second color temperature illuminants 2122. After an external power supply is connected to the circuit components 22, the light-emitting source 21 may emit light. Besides, it may also correspondingly adjust the strength of the currents and voltages of the three-primary-color light source 211, the first color temperature illuminants 2121, and the second color temperature illuminants 2122 of based on the needs, so as to change the intensity of the light emitted from the three-primary-color light source 211, the first color temperature illuminants 2121, and the second color temperature illuminants 2122. The circuit component 22 comprises an electrode member 221 and an electric connection member 222. The electrode member 221 is electrically connected with the electric connection member 222. The electrode member 221 is adapted for connecting with an external power supply. The first chips 2111, the second chips 21211, and the third chips 21221 are all electrically connected through the electric connection member 222. An external power supply is connected with the electrode member 221 to power on the light-emitting source 21 through the electric connection member 222 and allow the light-emitting source 21 to emit light.

[0041] Here, according to a first embodiment, the circuit components 22 are respectively electrically connected with the three-primary-color light source 211 and the first color temperature illuminants 2121. After the external power supply is connected to the circuit components 22, the light-emitting source 21 may emit light. Besides, it may also correspondingly adjust the strength of the currents and voltages of the three-primary-color light source 211 and the first color temperature illuminants 2121 based on the needs, so as to change the intensity of the light emitted from the three-primary-color light source 211 and the first color temperature illuminants 2121. The circuit component 22 comprises an electrode member 221 and an electric connection member 222. The electrode member 221 is electrically connected with the electric connection member 222. The electrode member 221 is adapted for connecting with the external power supply. The first chips 2111 and the second chips 21211

are electrically connected through the electric connection member 222. The external power supply is connected with the electrode member 221 to power on the three-primary-color light source 211 and the first color temperature illuminants 2121 through the electric connection member 222 to emit light.

[0042] Here according to a second embodiment, the circuit components 22 are respectively electrically connected with the three-primary-color light source 211 and the second color temperature illuminants 2122. After the external power supply is connected to the circuit components 22, the light-emitting source 21 may emit light. Besides, it may also correspondingly adjust the strength of the currents and voltages of the three-primary-color light source 211 and the second color temperature illuminants 2122 based on the needs, so as to change the intensity of the light emitted from the three-primary-color light source 211 and the second color temperature illuminants 2122. The circuit component 22 comprises an electrode member 221 and an electric connection member 222. The electrode member 221 is electrically connected with the electric connection member 222. The electrode member 221 is adapted for connecting with an external power supply. The first chips 2111 and the third chips 21221 are electrically connected through the electric connection member 222. The external power supply is connected with the electrode member 221 to power on the three-primary-color light source 211 and the second color temperature illuminants 2122 through the electric connection member 222 to emit light.

[0043] It is worth mentioning that the electrode member 221 comprises an anode 2211 and a set of cathodes 2212. The anode 2211 is for electrically connecting with the anode of an external power supply, while the cathodes 2212 are for electrically connecting with the cathode of the external power supply. A feature of the present invention is that the light-emitting sources 21 share one anode, such that it can reduce the arrangement of the anode 2211 on the substrate 10, so as to reduce manufacturing step, reduce mounting, welding, and soldering process, and saving power and materials like wire and etc.. The cathode 2212 further comprises a first cathode 22121, a second cathode 22122, and a third cathode 22123. The first cathode 22121 is electrically connected with the three-primary-color light source 211, the second cathode 22122 is electrically connected with the first color temperature illuminant 2121, and the third cathode 22123 is electrically connected with the second color temperature illuminant 2122. The working condition of the illumination module 1 includes electrically connecting the anode of the external power supply with the anode 2211 and electrically connecting the cathode of the external power supply with the first cathode 22121, the second cathode 22122, and the third cathode 22123 respectively, so as to set the illumination module 1 in a power on condition to turn the illumination module 1 into an illuminated and active status. It may respectively adjust the voltage strength of the three-primary-color light source 211, the first color temperature illuminants 2121, and the second color temperature illuminants 2122 to drive the light-emitting source 21 to change in color and brightness based on the actual needs of the user. It is worth mentioning that the first cathode 22121 has three cathode points, respectively electrically connected with the red light chip, the blue light chip, and the green light chip. One ends of the first chips 2111, the second chips 21211, and the third chips 21221 are mutually electrically connected with the anode 2211, while the other ends of the first chips

2111, the second chips 21211, and the third chips 21221 are respectively electrically connected with the cathodes 2212, wherein the anode 2211 is electrically connected with the anode of the external power supply, while the cathodes 2212 are electrically connected with the cathode of the external power supply.

[0044] Here, according to the above first embodiment, the first cathode 22121 is electrically connected with the three-primary-color light source 211 and the second cathode 22122 is electrically connected with the first color temperature illuminants 2121. The working condition of the illumination module 1 includes electrically connecting the anode of the external power supply with the anode 2211 and electrically connecting the cathode of the external power supply with the first cathode 22121 and the second cathode 22122 respectively, so as to set the illumination module 1 in a power on condition to turn the illumination module 1 into an illuminated and active status. It may respectively adjust the voltage strength of the three-primary-color light source 211 and the first color temperature illuminants 2121 to drive the light-emitting source 21 to change in color and brightness based on the actual needs of the user. It is worth mentioning that the first cathode 22121 has three cathode points, respectively electrically connected with the red light chip, the blue light chip, and the green light chip. One ends of the first chips 2111 and the second chips 21211 are mutually electrically connected with the anode 2211, while the other ends of the first chips 2111 and the second chips 21211 are respectively electrically connected with the cathodes 2212, wherein the anode 2211 is electrically connected with the anode of the external power supply, while the cathodes 2212 are electrically connected with the cathode of the external power supply.

[0045] Here, according to the above second embodiment, the first cathode 22121 is electrically connected with the three-primary-color light source 211 and the third cathode 22123 is electrically connected with the second color temperature illuminants 2122. The working condition of the illumination module 1 includes electrically connecting the anode of the external power supply with the anode 2211 and electrically connecting the cathode of the external power supply with the first cathode 22121 and the third cathode 22123 respectively, so as to set the illumination module 1 in a power on condition to turn the illumination module 1 into an illuminated and active status. It may respectively adjust the voltage strength of the three-primary-color light source 211 and the second color temperature illuminants 2122 to drive the light-emitting source 21 to change in color and brightness based on the actual needs of the user. It is worth mentioning that the first cathode 22121 has three cathode points, respectively electrically connected with the red light chip, the blue light chip, and the green light chip. One ends of the first chips 21221 and the third chips 2111 are mutually electrically connected with the anode 2211, while the other ends of the first chips 2111 and the third chips 21221 are respectively electrically connected with the cathodes 2212, wherein the anode 2211 is electrically connected with the anode of the external power supply, while the cathodes 2212 are electrically connected with the cathode of the external power supply.

[0046] Referring to Figs. 7 and 8, the present invention also relates to a lamp 2 that has a light source module. The lamp can be a daily lamp, such as desk lamp, working light, fancy lamp, and etc., as long as the light-emitting source of the daily lamp has been replaced by the light

source module 1 of the present invention. Preferably, the lamp is a ceiling lamp to be mounted on a setting surface, such as ceiling and etc.. A ceiling lamp is advantageous in hidden installation, compact installation space, and etc., which has widely utilized in our daily life. The lamp 2 with light source module comprises a lamp body 30 and a light source module 20 arranged on the lamp body 30, which allows the lamp 30 to emit various types of color light beams by combining different proportions of brightness of the three primary color lights or high luminous efficient white lights with various color temperatures by combining different proportions of brightness of cool and/or warm white lights. Accordingly, the lamp 2 with light source module can be widely utilized in various circumstances to satisfy the needs of the users.

[0047] Here, the lamp body 30 comprises a shell 31 and a connecting element 32, while the shell 31 and the light source module 20 are connected respectively through the connecting element 32. The shell 31 comprises a base 311 and a housing 312. The base 311 is detachably mounted on the housing 312. The connecting element 32 comprises a first connecting member 321 and a set of mounting members 322. The base 311 is detachably connected with the housing 31 through the first connecting member 321. The mounting members 322 are respectively symmetrically arranged on the two sides of the housing. The lamp body 30 is arranged on a mounting surface through the mounting members 322. Preferably, the mounting members 322 are resilient hanging elements.

[0048] It is worth mentioning that the shell 31 further comprises a face cover 313. The connecting element 32 further comprises a second connecting member 323. The face cover 313 is detachably connected with the base 311 through the second connecting member 323. The face cover 313 has a transparent side arranged in the middle thereof. The light beam emitted by the light source module 20 passes through the transparent side to be projected out.

[0049] It is worth mentioning that the shell 31 further comprises a lens 314 and a heat dissipation member 324 respectively arranged in the chamber of the housing 312. The light source module 20 is attached on the heat dissipation member 324. The light beam generated by the light source module 20 under the power-on state will be projected out through the lens 314. Here, the lens 314 serves to condense and guide the light emitted by the light source module 1. The light source module 1 is arranged in the inner side of the lens 314. Contrasting to conventional art, the light source module 1 sharingly utilizes only one lens 314, so as to achieve a spotlighting effect in a predetermined light angle. The predetermined light angle is usually 10°-60°. Accordingly, it also brings advantages, such as making the color of the combined and mixed light emitted by the light source module 1 even and natural, making the transitions of the light spots natural, avoid noise colors, and etc..

[0050] It is worth mentioning that the light source modules 1 according to the above four embodiments may respectively be mounted in an accommodating chamber of the lamp body 31 based on the needs, so as to satisfy various user demands.

[0051] One skilled in the art will understand that the embodiment of the present invention as

shown in the drawings and described above is exemplary only and not intended to be limiting.

[0052] Objectives of the present invention are completely and effectively implemented. Notions of the functions and structures of the present invention have been shown and described in the embodiments, whereas implementations of the present invention may have modifications or changes in any ways without going against the above notions.

REFERENCES CITED IN THE DESCRIPTION

Cited references

This list of references cited by the applicant is for the reader's convenience only. It does not form part of the European patent document. Even though great care has been taken in compiling the references, errors or omissions cannot be excluded and the EPO disclaims all liability in this regard.

Patent documents cited in the description

- WO2009109387A [0003]

Patentkrav

1. Lyskildemodul (1), der omfatter:

et substrat (10); og

5 en lyskildeenhed, der omfatter en lysemitterende kilde (21), der er tilvejebragt på substratet (10), hvor den lysemitterende kilde endvidere omfatter:

en lyskilde med tre primærfarver (211), der er anbragt på substratet (10), og
mindst en lyskilde med justerbar farvetemperatur (212), anbragt henholdsvis
10 på substratet (10) og på ydersiden af lyskilden med tre primærfarver (211),
således at det muliggøres, at lyskilden med tre primærfarver (211) og lyskilden
med justerbar farvetemperatur (212) udsender forskellige lyskilder (212) på en
kombinationsmåde,

hvor lyskilden med justerbar farvetemperatur (212) omfatter et sæt af belysningsmidler med en første farvetemperatur (2121) og et sæt af belysningsmidler med en anden farvetemperatur (2122), hvor belysningsmidlerne med den første farvetemperatur (2121) er anbragt på de to respektive sider af lyskilden med tre primærfarver (211), hvor belysningsmidlerne med den anden farvetemperatur (2122) er anbragt ved den udvendige side af belysningsmidlet med den første farvetemperatur (2121), således at belysningsmidlerne med den første farvetemperatur befinder sig mellem lyskilden med tre primærfarver og belysningsmidlerne med den anden farvetemperatur,

15 lyskilden med tre primærfarver (211) omfatter et sæt af første chips (2111) og et første dæklag (2112), hvor de første chips er anbragt i længderetningen og flugter med en A-akse på substratet (10), hvor det første dæklag (2112) tilsvarende dækker overfladen af de første chips (2111) i længderetningen langs A-aksen,

20 belysningsmidlet med den første farvetemperatur (2121) omfatter et sæt af anden chips (21211) og et andet dæklag (21212), hvor de anden chips er anbragt i længderetningen og flugter med A-aksen, hvor det andet dæklag (21212) tilsvarende dækker overfladen af de anden chips (21211) i længderetningen langs A-aksen,

30 belysningsmidlet med den anden farvetemperatur (2122) omfatter et sæt af tredje chips (21221) og et tredje dæklag, hvor de tredje chips (21221) er an-

bragt i længderetningen og flugter med A-aksen, hvor det tredje dæklag tilsvarende dækker overfladen af de tredje chips (21221) i længderetningen langs A-aksen,

5 de anden chips (21211) er anbragt ved de to respektive sider af de første chips (2111), hvor de tredje chips (21221) er anbragt ved den udvendige side af den anden chips (21211), således at de anden chips befinder sig mellem de første chips (2111) og de tredje chips (21221),

10 lyskildeenheden (20) omfatter en kredsløbskomponent (22), der er anbragt på substratet (10), hvor lyskilden med tre primærfarver (211) og lyskilden med justerbar farvetemperatur (212) hver især er elektrisk forbundet med kredsløbskomponenten (22), hvor en ekstern strømforsyning er elektrisk forbundet med den lysemitterende kilde (21) gennem kredsløbskomponenten (22), således at det muliggøres, at den lysemitterende kilde (21) udsender forskellige farver af lys på en kombinationsmåde baseret på et forudbestemt behov,

15 kredsløbskomponenten (22) omfatter et elektrodeelement og et elektrisk forbindelseselement, hvor elektrodeelementet og det elektriske forbindelseselement er elektrisk forbundet med henholdsvis de første chips (2111), de anden chips (21211) og de tredje chips (21221), hvor den eksterne strømforsyning, gennem elektrodeelementet og det elektriske forbindelseselement, tillader lyskilden med tre primærfarver (211), belysningsmidlerne med den første farvetemperatur (2121) og belysningsmidlerne med den anden farvetemperatur (2122) at være i en aktiv status til udsendelse af lys,

20 elektrodeelementet yderligere omfatter en anode (2211) og et sæt af katoder (2212), hvor ene ender af de første chips (2111), de anden chips (21211) og de tredje chips (21221) er indbyrdes elektrisk forbundet med anoden (2211), mens de anden ender af de første chips (2111), de anden chips (21211) og de tredje chips (21221) hver især er elektrisk forbundet med katoderne (2212), hvor anoden (2211) er elektrisk forbundet med anoden (2211) af den eksterne strømforsyning, mens katoderne (2212) er elektrisk forbundet med katoden af

30 den eksterne strømforsyning,

den første chip er en LED-chip med tre primærfarver, som omfatter et trevejschipsæt af henholdsvis en chip med rødt lys, en chip med blått lys og en chip med grønt lys, hvor det første dæklag (2112) er et transparent kolloid af

silikone eller epoxyharpiks, således at det muliggøres, at lys af forskellige farver udsendes på en kombinationsmåde gennem det første dæklag (2112) ved justering og konfigurerings af det numeriske forhold mellem spændingen og strømmen af trevejschipsættet af LED-chippen med tre primærfarver,

5 den anden chip og den tredje chip begge er LED-chips med blåt lys, hvor det andet dæklag (21212) er et kolloid med en bestanddel af YAG-phosphor i en bestemt andel, således at det muliggøres, at de anden chips (21211) udsender koldt lys af hvid farve med en farvetemperatur på 4500K-7000K gennem det

10 andet dæklag (21212), mens det tredje dæklag er et kolloid med en bestanddel af YAG-phosphor i en anden bestemt andel, således at det muliggøres, at de tredje chips (21221) udsender varmt lys af hvid farve med en farvetemperatur på 1000K-4500K gennem det tredje dæklag, således at det er muligt for lyskildemodulet (1) at udsende hvidt lys med en farvetemperatur på 1000K-7000K på en kombinationsmåde gennem henholdsvis det andet dæklag (21212) og

15 det tredje dæklag, og tilsvarende således at det kan være med justerbar farvetemperatur ved belysning med hvidt lys.

2. Lampe (2) med et lyskildemodul (1), omfattende: et lampelegeme (30); og et lyskildemodul (1) ifølge krav 1, hvor lyskildemodulet er anbragt i et optagelseskammer af lampelegemet, hvor lyskildemodulet udsender lys af forskellige farver på en kombinationsmåde gennem justering eller ændring af de numeriske værdier af spændingen eller strømmen af den eksterne strømforsyning.

20

3. Lampe (2) med et lyskildemodul (1) ifølge krav 2, hvor lampelegemet (30) omfatter en skal (31), hvor skallen (31) omfatter et hus (312) og en linse (314), der er anbragt på huset (312), hvor lysstrålen af lyskildemodulet udsendes gennem linsen (314).

25

DRAWINGS

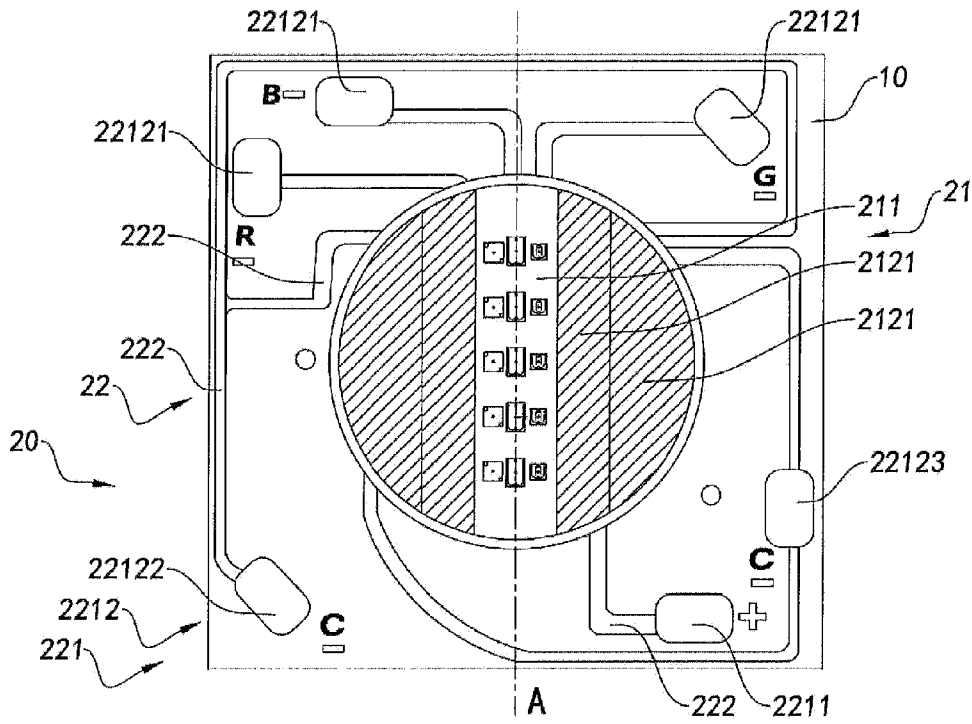

Fig.1A

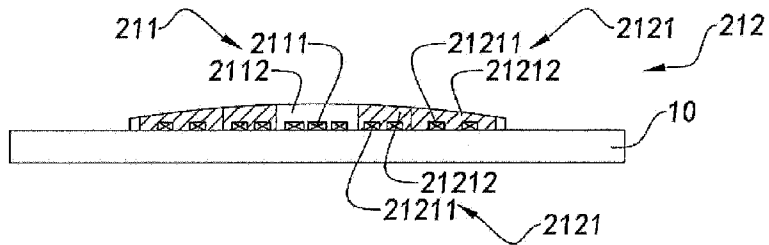

Fig.1B

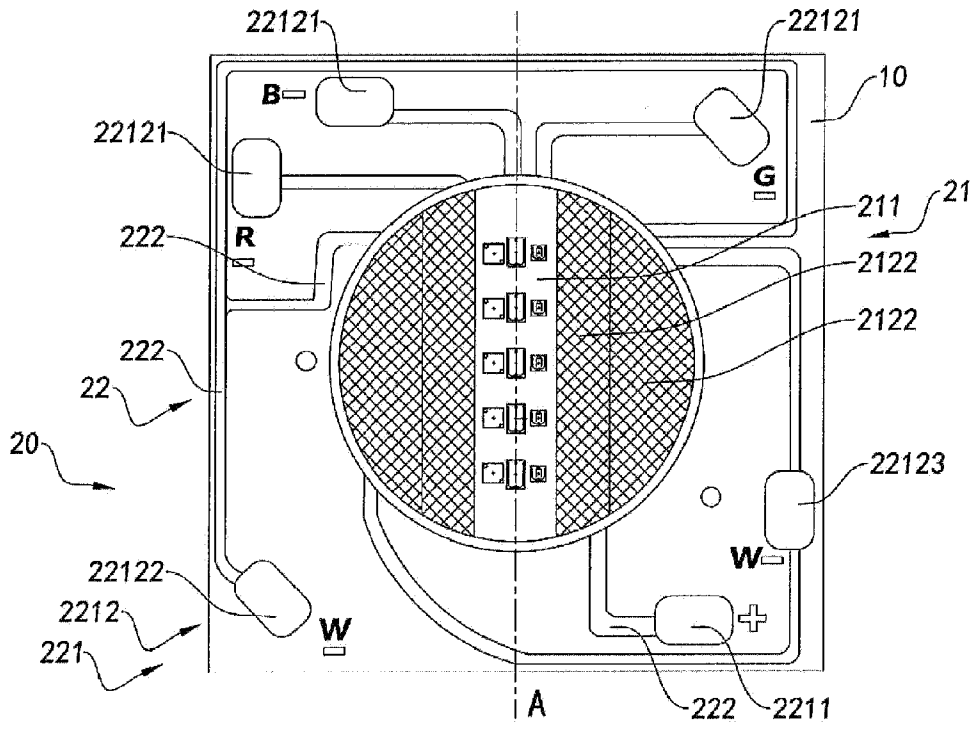

Fig.2A

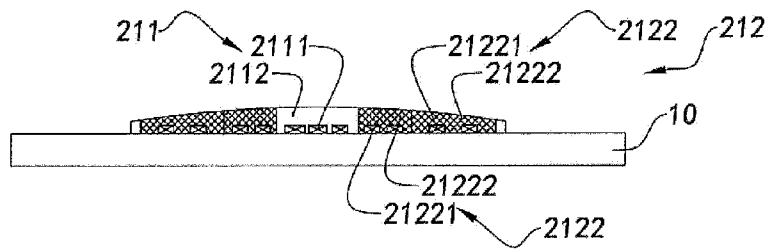

Fig.2B

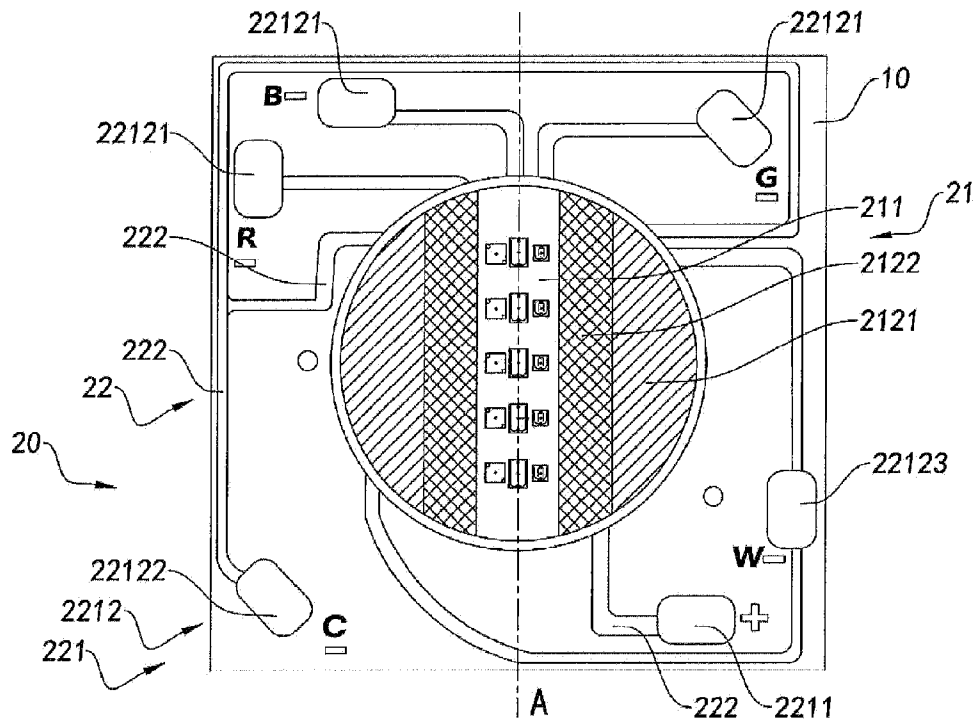

Fig.4A

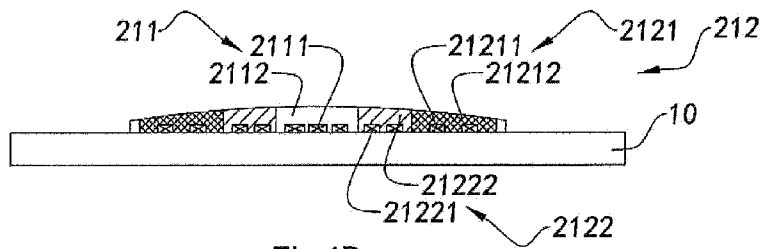

Fig.4B

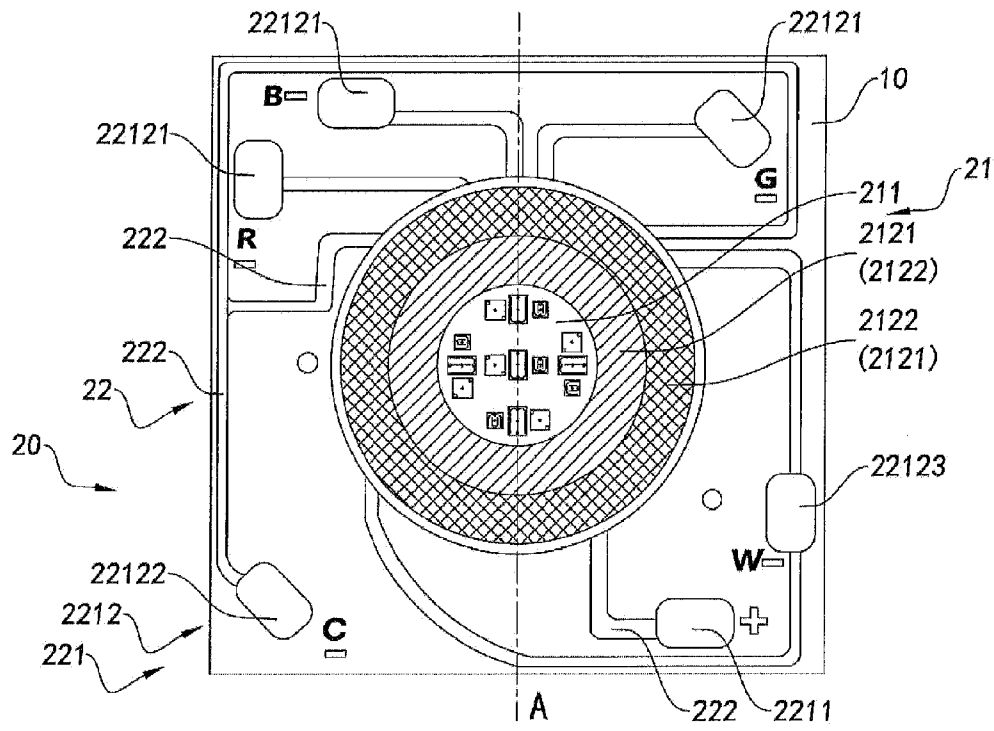

Fig.5A

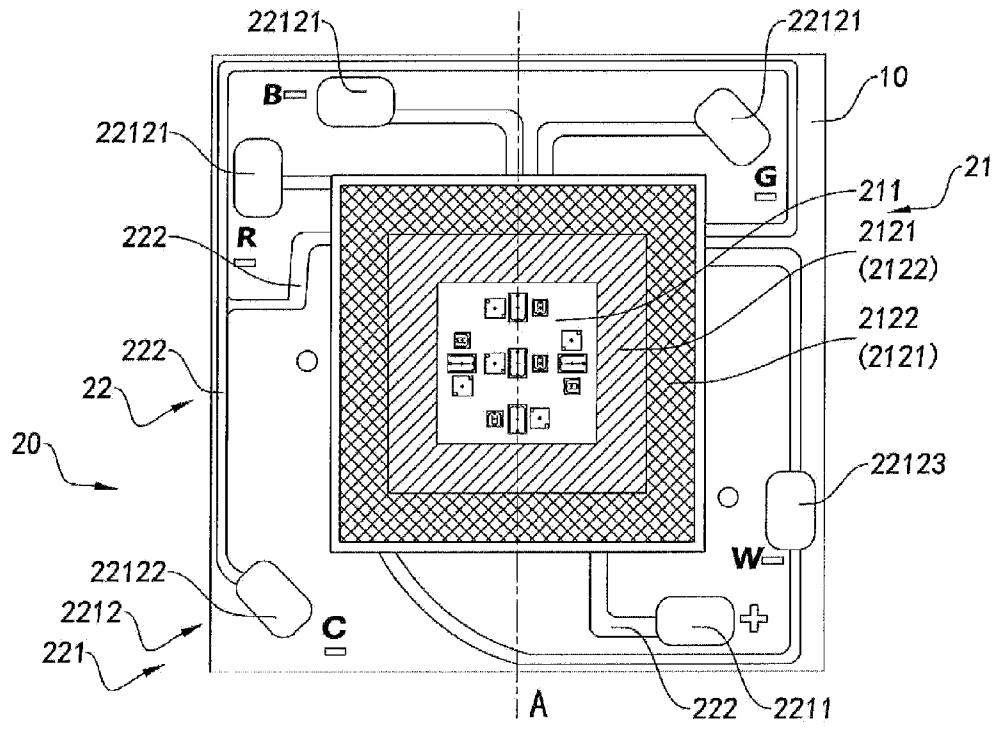

Fig.5B

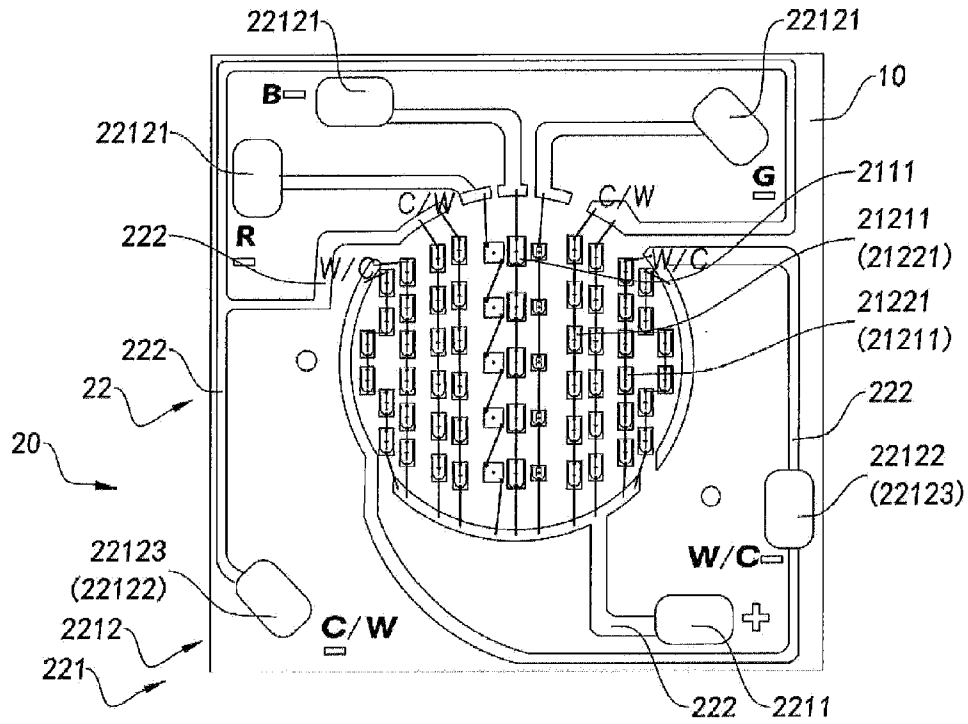

Fig.6

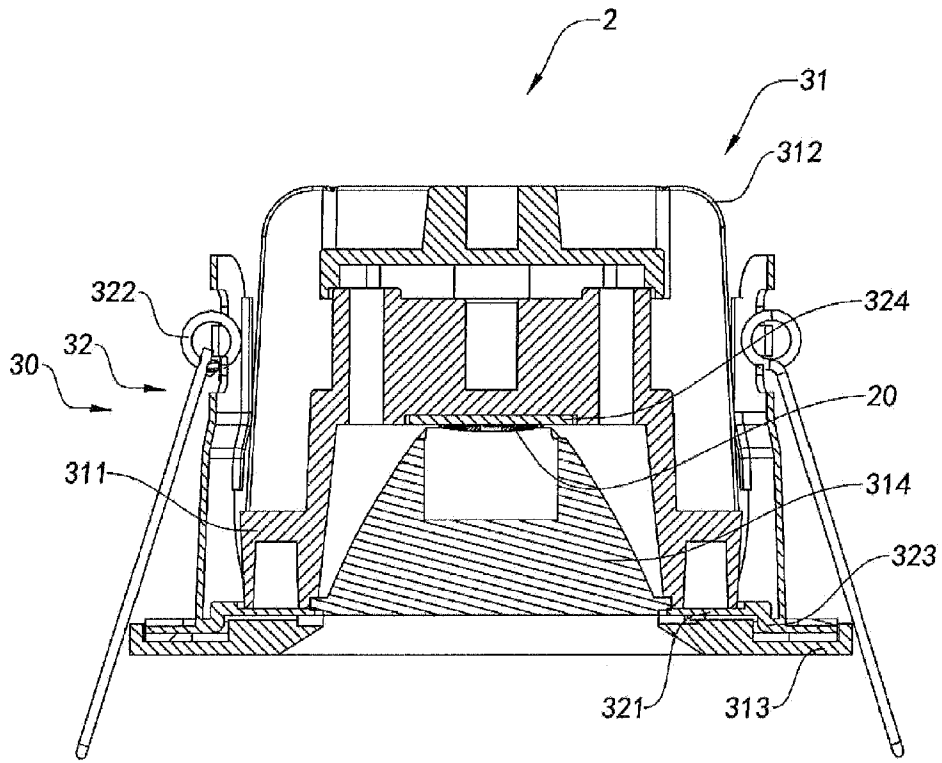

Fig.7

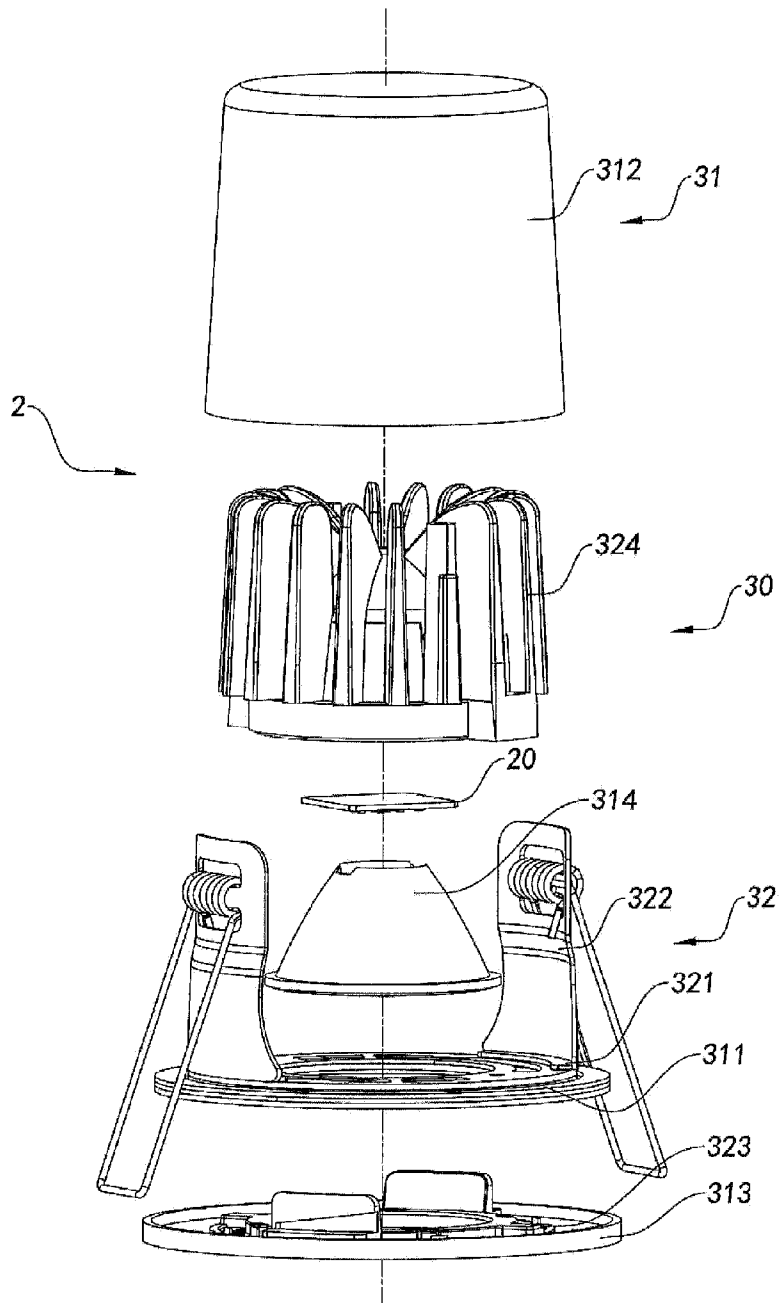

Fig.8