

Dec. 29, 1931.

W. P. COOK

1,838,251

STROPPING DEVICE FOR SAFETY RAZOR BLADES

Filed May 25, 1925

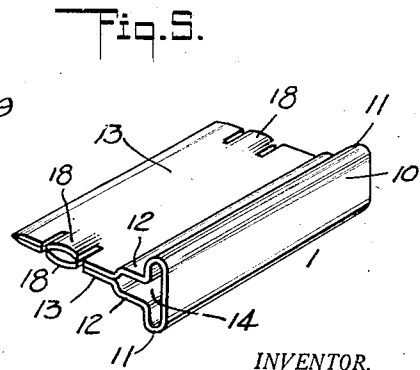
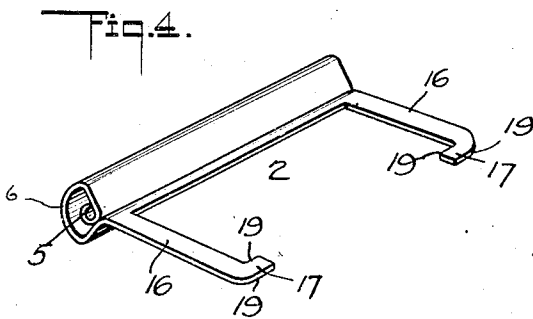
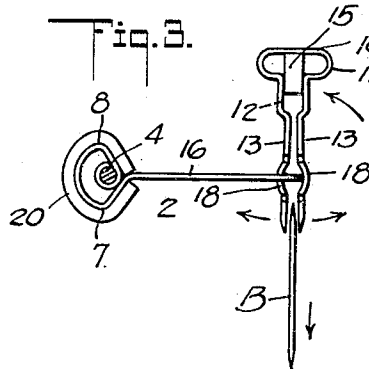
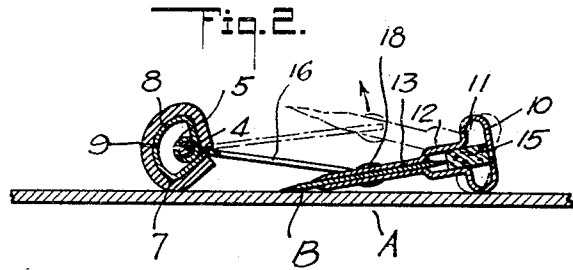
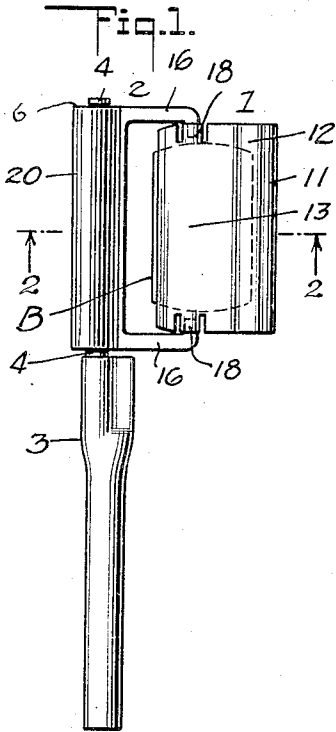

INVENTOR.
WILLIAM P. COOK
BY *Munn & Co.*
ATTORNEYS.

UNITED STATES PATENT OFFICE

WILLIAM PEDRICK COOK, OF LOS ANGELES, CALIFORNIA, ASSIGNOR OF ONE-FOURTH TO
WILLIAM A. HINES, OF HOLLYWOOD, CALIFORNIA

STROPPING DEVICE FOR SAFETY RAZOR BLADES

Application filed May 25, 1925. Serial No. 32,692.

This invention relates to stropping devices for safety razor blades, and has for its primary object the provision of a device of this character for use in stropping either single or double edged blades and wherein use of gearing is eliminated in the means employed herein for oscillating the blade holder in operative time with the respective right and left strokes of the device over a stropping surface.

A further object of the invention is to provide a device of this character embodying a novel form of blade holder whose inherent resiliency functions to positively grip and hold the blade during the stropping operation and with which said holder, means are incorporated to adjust same to blade applying and removing position.

A further object of the invention is to provide a stropping device having a blade holder designed and constructed so as to eliminate possibility of accidental cutting of the fingers in the act of attaching the blade to or removing same from the holder.

Another object of the invention is to provide a device of this character having a blade holder which will adapt itself to blades of relatively different makes and widths and for maintaining an exposed condition of one edge of the blade during the stropping operation.

A still further object of the invention is to provide a device of this character which shall be simple and inexpensive of construction; one which shall be reliable of action at all times; and one which is strong, light of weight, compact and extremely durable.

With these and other objects in view, which will be fully explained and made obvious as the description goes forward, I shall now proceed to set forth the details of construction of the device and shall make particular reference to the accompanying drawings, wherein

Figure 1 is a plan view of the device;

Figure 2 is a section taken on line 2—2 of Figure 1;

Figure 3 is a view in edge elevation showing the manner of releasing the jaws of the blade holder; and

Figures 4 and 5, respectively, are perspective views of the blade holder and its actuating and supporting frame.

In carrying the invention into practice, I employ three essential co-operating parts, to wit: blade holder 1, oscillatory frame and blade-holder-carrier 2 and handle or support 3 for said carrier 2.

The handle 3 may be of any suitable well-known construction, and same is provided with a pin or bearing 4 which constitutes the axis about which the frame 2 and holder 1 are adapted to oscillate.

The oscillatory frame 2 is preferably struck-up from a single piece of metal having a knuckle 5 through which the bearing pin 4 passes. From the knuckle 5, the metal is looped at 6 to provide fulcrum surfaces 7 and 8 and a connecting arcuate surface 9, whereby when the device is moved in the direction of the arrow, Figure 2, the blade holder 1 will be held at the angle illustrated and necessary to hold one side of one edge of the blade in effective stropping contact with the strop A. At this time, the fulcrum surface 7 rides over and against the strop until the end of the stroke is reached. When force is exerted to change the direction of the stropping stroke, the surface 9 is effective to position the surface 8 against the strop, thus moving the holder 1 over to the left of the axis 4. At this time, the device functions to apply the other side of the said one edge against the strop, as will be understood.

My blade holder 1 is formed of a single piece of springy metal or other suitable well-known material, and it comprises an elongated loop 10 having elevating ends 11, 11, lateral offsets, 12, 12 and effecting blade-clamping walls 13, 13. The walls of the loop 10 and the aforesaid offsets 12, 12 mutually define a space 14 for a cork or other yieldable blade abutment and edge spacer 15. As stated, the holder is springy, and incident thereto the walls 13, 13 thereof are normally pressed in yielding relative contact. It follows that when a blade B is inserted between said walls, it will be firmly clamped thereby and that when one edge of the blade, Figure 2, is in contact with the spacer 15, the other

edge is projected beyond the free edges of the walls 13, 13 in parallel relation thereto. The blade is now operatively arranged so that it can be moved over the strop A in the sharpening operation.

5 The frame 2 which I also construct from a single piece of metal is provided with parallel side arms 16, 16 having terminal flat lugs 17, 17. These lugs are sandwiched between the walls 13, 13, and are normally parallel
10 therewith so that the frame 2 and holder 1 turn together. The walls 13, 13 are formed with correlated concavo-convex cam-like elements 18, 18 and by turning the holder 1 on
15 the frame 2 as shown in Figure 3, the edges 19 come against the concaved faces of the elements 18 to spread the walls 13, 13 apart. The blade B can now be freely inserted in or removed from the holder in a very quick and
20 convenient manner and without fear of cutting the fingers.

If desired, the loop 6 may be faced with a leather or rubber sleeve 20 which lends friction thereto to assist in the oscillatory action
25 of the parts. It shall be understood that normally there is sufficient clearance between the flat lugs 17 and the elements 18 to cause the blade holder to assume an operative angular position with respect to the strop A with-
30 out releasing the blade B, and that this clearance is not so great as to not permit the holder to oscillate properly with the frame 2. It is determined to the degree that the holder compensates itself to the proper angle on each
35 turn of the holder at the end of the respective strokes.

Although I have described and shown only one form of stropping device for safety razor blades, it is to be understood that various
40 changes and modifications may be made therein without departing from the spirit of the invention and the spirit and scope of the appended claims.

It will be observed that the elements 18,
45 18 and the lugs 17, 17 are located with respect to the medial line of the holder so that the loop end 10 of the holder normally overbalances the holder when the lugs 17, 17 hang hinge-like from the aforesaid elements 18, 18. In consequence thereof, it follows that when the end of the stroke is
50 reached, and immediately prior to the action of turning the holder over to an opposite working position, the holder is canted to the dotted line position shown in Figure 2. Through this gravitational functioning of
55 the holder, the exposed edge of the razor blade is positively elevated to a point above the plane of the strop so as to prevent any gouging of the strop or other injury thereto
60 on reversing the strokes during the stropping operation.

I claim as my invention:

65 1. In a device of the character described, a frame, a blade holder having walls nor-

mally urged to a position to clamp a blade therebetween, lugs on the frame interposed between the walls of the blade holder for mounting the latter for pivotal movement as a unit in the frame, the lugs being of a cross-sectional contour such as to spread the walls
70 of the holder when the latter is moved to a predetermined position in the frame so as to permit a blade to be freely inserted or removed from between the walls.

2. In a device of the character described, a frame, a blade holder having walls normally urged to a position to clamp a blade therebetween, and means on the frame and holder coacting to support the holder for
80 movement bodily in the frame and to spread the walls of the holder when the latter is moved to a predetermined position in the frame so as to permit a blade to be inserted or removed from between the walls.

3. A blade stropping device, comprising a frame adapted to be oscillated on a strop, a blade holder having parts normally urged to a position to clamp a blade therebetween, and coacting means on the frame and holder
90 by which the holder is moved first to one side of the frame and then the other and simultaneously turned to present to the surface of a strop first one side and then the other of a blade held between the walls of
95 the holder when the frame is oscillated on the surface of a strop, said means operating to spread the holder walls apart when the holder is moved to a position other than any position occupied during oscillation of the
100 frame on the strop whereby, a blade can be removed or inserted to or from the holder.

4. A blade stropping device as embodied in claim 3 wherein said means includes flat lugs on the frame and dished elements on the
105 holder arranged in pairs with the elements of each pair receiving a lug therebetween.

WILLIAM PEDRICK COOK.

110

115

120

125

130