

(19) World Intellectual Property Organization
International Bureau



(43) International Publication Date
10 March 2011 (10.03.2011)

(10) International Publication Number
WU 2011/028823 A1

- (51) International Patent Classification:
D21H 21/24 (2006.01)
- (21) International Application Number:
PCT/US2010/047560
- (22) International Filing Date:
1 September 2010 (01.09.2010)
- (25) Filing Language: English
- (26) Publication Language: English
- (30) Priority Data:
61/275,743 1 September 2009 (01.09.2009) US
- (71) Applicants (for all designated States except US): **ARMSTRONG WORLD INDUSTRIES, INC.** [US/US]; 2500 Columbia Avenue, P.O. Box 3001, Lancaster, Pennsylvania 17604-3001 (US). **THE UNIVERSITY OF MAINE SYSTEM BOARD OF TRUSTEES** [US/US]; 107 Maine Avenue, Bangor, Maine 04401 (US).
- (72) Inventors; and
- (75) Inventors/ Applicants (for US only): **BEAUPRÉ, James, J.** [US/US]; 626 Beaulieu Road, St. David, Maine 04773 (US). **NEFVANDT, David, J.** [AU/US]; 112 Maple Street, Bangor, Maine 04401 (US). **KEHRER, Kenneth, P.** [US/US]; 1019 Shadowstone Drive, Lancaster, Pennsylvania 17603 (US).
- (74) Agents: **WHITE, Geoffrey, K.** et al; McNeese Wallace & Nurick, LLC, 100 Pine Street, P.O. Box 1166, Harrisburg, Pennsylvania 17108-1166 (US).
- (81) Designated States (unless otherwise indicated, for every kind of national protection available): AE, AG, AL, AM, AO, AT, AU, AZ, BA, BB, BG, BH, BR, BW, BY, BZ, CA, CH, CL, CN, CO, CR, CU, CZ, DE, DK, DM, DO, DZ, EC, EE, EG, ES, FI, GB, GD, GE, GH, GM, GT, HN, HR, HU, ID, IL, IN, IS, JP, KE, KG, KM, KN, KP, KR, KZ, LA, LC, LK, LR, LS, LT, LU, LY, MA, MD, ME, MG, MK, MN, MW, MX, MY, MZ, NA, NG, NI, NO, NZ, OM, PE, PG, PH, PL, PT, RO, RS, RU, SC, SD, SE, SG, SK, SL, SM, ST, SV, SY, TH, TJ, TM, TN, TR, TT, TZ, UA, UG, US, UZ, VC, VN, ZA, ZM, ZW.
- (84) Designated States (unless otherwise indicated, for every kind of regional protection available): ARIPO (BW, GH, GM, KE, LR, LS, MW, MZ, NA, SD, SL, SZ, TZ, UG, ZM, ZW), Eurasian (AM, AZ, BY, KG, KZ, MD, RU, TJ, TM), European (AL, AT, BE, BG, CH, CY, CZ, DE, DK, EE, ES, FI, FR, GB, GR, HR, HU, IE, IS, IT, LT, LU, LV, MC, MK, MT, NL, NO, PL, PT, RO, SE, SI, SK, SM, TR), OAPI (BF, BJ, CF, CG, CI, CM, GA, GN, GQ, GW, ML, MR, NE, SN, TD, TG).
- Published:
— with international search report (Art. 21(3))

(54) Title: CELLULOSIC PRODUCT FORMING PROCESS AND WET FORMED CELLULOSIC PRODUCT

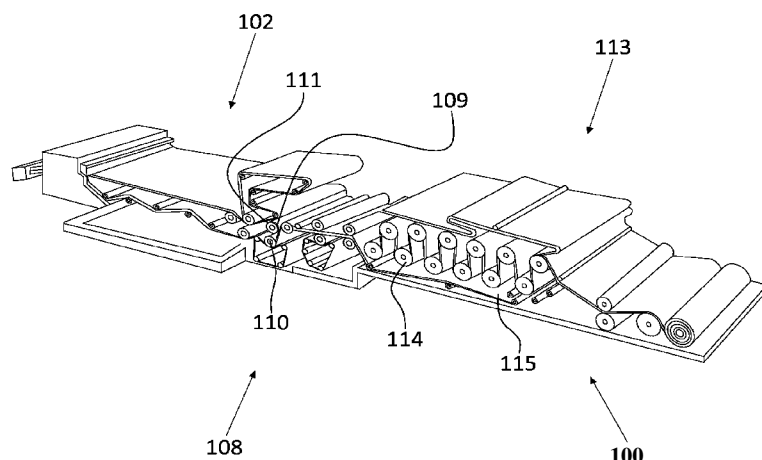

FIG. 1

(57) Abstract: According to the disclosure, a wet form cellulose product forming process and a wet formed cellulose product are disclosed. The process includes providing a slurry, forming the slurry into a cellulose product, dewatering the cellulose product, and drying the cellulose product. Further dewatering of the cellulose product occurs through a non-mechanical mechanism.



WO 2011/028823 A1

- 1 -

CELLULOSIC PRODUCT FORMING PROCESS AND WET FORMED CELLULOSIC PRODUCT

PRIORITY

[0001] This application claims priority to and benefit of U.S. Provisional Patent Application No. 61/275,743, filed September 1, 2009, and titled "Enhancement of Water Removal in Pressing and/or Drying Portions by the Addition of a Cationic Surfactant," which is hereby incorporated by reference in its entirety.

FIELD OF THE INVENTION

[0002] The present invention is directed to cellulosic product forming processes and cellulosic products. More specifically, the present invention is directed to a cellulosic product forming process including non-mechanical dewatering and a wet formed cellulosic product.

BACKGROUND OF THE INVENTION

[0003] The manufacture of a cellulosic product such as a sheet of paper from a pulp slurry includes forming portions, pressing portions, and drying portions. Forming the cellulosic product (for example, the sheet of paper) can involve the removal of water by forming section drainage, pressing, and drying. There has been much work conducted in exploring mechanical processes of enhancing removal of water prior to the drying in order to reduce the amount of energy needed for the drying process. As such, there is a need for improvements in the forming section drainage and pressing section drainage that do not require substantial capital investment.

[0004] As paper machines age and speed requirements increase, the machines tend to become limited by the drying portions and/or pressing portions. This limits the rate at which water can be removed. Speed above a predetermined rate produces a sheet with higher than desirable moisture levels.

[0005] Dewatering advancements in the forming portions and pressing portions have generally been mechanical. A higher dryness coming from the forming portions into the pressing portions may lead to a higher dryness exiting the pressing portions and leads to a

- 2 -

lower water load entering the drying portions, thus allowing for a savings in energy or an increase in production.

[0006] Pressing portions can be the last chance to increase the dryness of the sheet before entering the drying portions. In pressure controlled pressing portions, the resistance to flow between the fibers of the sheet is insignificant. The dryness of the sheet is dictated by the flow of water exiting the fiber wall. Water in the controlled pressing portions involves a flow phenomenon with the press impulse being the major driving force. Water is removed proportional to the water load of the sheet at a maximum operational pressure. A greater dryness can be achieved by increasing the pressure applied to the sheet, however, above the maximum operational pressure, the structural integrity of the sheet is overcome and the sheet is crushed, creating a lower quality product. Pressure controlled pressing portions apply to single felted presses with basis weights up to 100 g/m² and to double felted presses with basis weights up to 150 g/m². The pressure controlled pressing portions can be extended to heavier sheets at higher speeds with modern shoe presses.

[0007] Conversely, flow controlled pressing portions are defined by conditions where the rate of water removal is constant at a given set of pressing parameters. This is a sign of poor operational pressing conditions. In the flow controlled pressing portions, water removal follows Darcy's law, as dryness is a function of the press impulse with no independent effect of pressure or time. This condition arises when the water which is being pressed from the sheet is removed at a slower rate than it is created, defeating the purpose of applying a greater pressure. To overcome the limitation, the rate at which water is carried away from the pressing zone is increased in order to achieve a greater dryness out of the press and to revert to the pressure controlled regime.

[0008] In Stratton R. A., *Use of polymers in wet pressing*, Tappi Proceedings Papermakers Conference, pp. 179-185 (1982), hereinafter "Stratton," which is incorporated by reference in its entirety, various cationic wet end polymers were utilized to demonstrate that increases of up to about 1% to 2% solids out of a press section are possible by addition of the polymers to the wet end. Stratton focused solely on the use of the polymers in wet pressing. Increasing the concentration of the polymers resulted in increased solids.

- 3 -

[0009] Busker L. H., Cronin D. C , *The relative importance of wet press variables in water removal*, Pulp and Pap Can, 85:87-101 (1984), which is incorporated by reference in its entirety, suggested that additives are not apt to be the most productive areas of research and development for large gains in water removal.

[0010] In Wegner T H, *The effect of polymeric additive on papermaking*, Tappi J 7:107-111 (1987), hereinafter "Wegner," which is incorporated by reference in its entirety, the effects of cationic polyacrylamide on water removal in the forming, pressing, and drying sections were discussed. Wegner observed that while an increase in drainage was evident, the sheet behavior during wet-press dewatering was unaffected. It was noted, however, that wet pressing with a cationic polyacrylamide could compensate for higher moisture levels entering the press while maintaining the solids content exiting the press.

[0011] In Springer A, Nabors L A, Bhatia O, *The influence of fiber, sheet structural properties, and chemical additives on wet pressing*, Tappi J, 4(2):221-228 (1991), hereinafter "Springer," which is incorporated by reference in its entirety, chemical additives such as cationic polyacrylamides were shown to have an indirect influence on wet pressing. These chemical additives increased solids exiting the forming section. However, the gains associated with the increased solids were lost during the pressing section. Springer indicated that for sheets entering the press at equal moistures, the additives had no effect on the outgoing solids content. Springer postulated that if an additive was to have any effect on press enhancement, the additive must be able to penetrate the fiber structure and influence its water holding capacity.

[0012] What is needed is a process of forming cellulosic products and cellulosic products, capable of dewatering while not suffering from the above-drawbacks.

SUMMARY OF THE INVENTION

[0013] In an exemplary embodiment, a wet form cellulosic product forming process includes providing a slurry, forming the slurry into a cellulosic product, dewatering the cellulosic product, and drying the cellulosic product. The cellulosic product further dewatered through a non-mechanical mechanism, the non-mechanical mechanism being provided by a soluble

- 4 -

surfactant selected from the group consisting of a cationic surfactant, an anionic surfactant, zwitterionic surfactant, a nonionic surfactant, and combinations thereof.

[0014] In another exemplary embodiment, a wet formed cellulosic product forming process includes providing a slurry, forming a cellulosic product from the slurry, pressing the cellulosic product to dewater the cellulosic product, and drying the cellulosic product. The cellulosic product is further dewatered during the forming and the pressing of the cellulosic product.

[0015] In another exemplary embodiment, a wet formed cellulosic product includes cetyl trimethylammonium bromide ((C₁₆H₃₃)N(CH₃)₃Br).

[0016] An advantage of an embodiment of the present invention includes the ability to reduce energy consumption in wet form processes due to the non-mechanical dewatering.

[0017] An advantage of an embodiment of the present invention includes the ability to increase production rate in wet form processes due to the non-mechanical dewatering.

[0018] Another advantage of an embodiment of the present invention includes the ability to increase an overall amount of dewatering due to a combination of mechanical and non-mechanical dewatering.

[0019] Other advantages will be apparent from the following description of exemplary embodiments of the disclosure.

BRIEF DESCRIPTION OF THE DRAWINGS

[0020] FIG. 1 shows an exemplary paper forming system according to the disclosure.

[0021] FIG. 2 shows a plot of the relationship between water retention value and quantity of a surfactant according to an exemplary embodiment of the disclosure for unprinted pulp.

[0022] FIG. 3 shows a plot of the relationship between water retention value and quantity of a surfactant according to an exemplary embodiment of the disclosure for printed pulp.

- 5 -

[0023] FIG. 4 shows a plot of the relationship between surface tension and quantity of several exemplary surfactants and comparative examples according to an exemplary embodiment of the disclosure.

[0024] FIG. 5 shows a plot of the relationship between water retention value and quantity of several exemplary surfactants and comparative examples according to an exemplary embodiment of the disclosure.

[0025] FIG. 6 shows a plot of the relationship between WRV and exemplary methods of using an exemplary surfactant in conjunction with a retention package according to an exemplary embodiment of the disclosure.

[0026] FIG. 7 shows a plot of the relationship between surface tension and exemplary methods of using an exemplary surfactant in conjunction with a retention package according to an exemplary embodiment of the disclosure.

[0027] Other features and advantages of the present invention will be apparent from the following more detailed description of the preferred embodiment, taken in conjunction with the accompanying drawings which illustrate, by way of example, the principles of the invention.

DETAILED DESCRIPTION OF THE INVENTION

[0028] Provided is a cellulosic product forming process including non-mechanical dewatering and a cellulosic product formed by non-mechanical dewatering. In one embodiment, the cellulosic product forming process includes providing a slurry, forming the slurry into the cellulosic product, dewatering the cellulosic product (for example, by pressing), and drying the cellulosic product. The cellulosic product is further dewatered through a non-mechanical mechanism. The non-mechanical mechanism can be a surfactant, can result in increased solids of above about 1%, about 2%, or more.

[0029] As will be appreciated, the cellulosic products can be paper, ceiling board, paneling, fiberboard, cardboard, cellulosic composites, MDF, HDF, decking, flooring, or any other suitable wet formed cellulosic product. Referring to FIG. 1, in one embodiment, the cellulosic product is paper produced by a paper forming system 100. In this embodiment, the slurry is a

- 6 -

pulp slurry formed into the paper by forming portion 102. It will be appreciated that the pulp slurry can be formed by any suitable pulping process, any suitable disintegrating process, any suitable pulverizing process, and/or other suitable processes for forming cellulosic components of a slurry. As used herein, the terms "pulp," "pulping," and grammatical variations refer to any of these processes or any combination of these processes. The forming portion 102 dewater the paper by drainage of water through a fiber mat. The water is removed by gravity through free drainage and subsequently by generating a pressure gradient across the fiber mat. This pressure gradient is created by placing stationary hydrodynamic foils underneath a forming fabric. The forming fabric provides initial stability of the newly formed sheet. The speed of the sheet over the hydrodynamic foils results in a pressure drop behind the hydrodynamic foils due to Bernoulli's principle. As the sheet progresses through the forming portion 102, the hydrodynamic foils are assisted by the addition of vacuum boxes to further dewater the sheet. At the end of the forming section, the sheet enters the pressing portion at about 20% solids depending upon the basis weight of the sheet (heavier sheets are wetter).

[0030] Upon exiting the forming portion 102, the sheet enters the pressing portion 108. The pressing portion 108 can include any suitable pressing mechanisms. In one embodiment, the pressing portion 108 removes water from the sheet and compresses the sheet so that fiber-fiber hydrogen bonding can begin to occur. The pressing portion 108 continues the dewatering that began in the forming portion 102. A press nip 109, where the dewatering of the sheet occurs due to a pressure pulse, is located between a first press roll 110 and a second press roll 111. Of these two rolls 110, 111, one is covered with rubber and the second is either a steel or composite covered roll. The sheet is transferred from the forming fabric in the forming portion 102 to felts in the pressing portion 108. The forming fabric and the felts provide support for the sheet which cannot yet support its own weight and assist in carrying excess water from the sheet. The sheet leaves the pressing portion 108 at about 40% to about 50% solids.

[0031] After the pressing portion 108, the sheet enters the drying portion 113. The drying portion 113 can include any suitable drying mechanisms. The drying portion 113 can be the most expensive portion of the process to install in terms of the capital cost of equipment and installation. Further, the drying portion 113 can have the greatest operational cost due to high energy consumption for evaporating remaining water from the sheet. In one embodiment, the sheet enters the drying portion 113 at about 50% to about 60% moisture and passes over steam

- 7 -

heated rolls 114 to apply energy for drying. Additionally or alternatively, drying can occur by steam heat in dryer cans, infrared dryers, natural gas dryers, other suitable dryers, or any suitable combination. In one embodiment, dryer felts in a two tier steam dryer are used to initially aid in supporting the sheet and, later, in the drying portion 113 to hold the sheet tightly to the steam heated rolls 114 to increase heat transfer. The moisture content of the final product is about 5%.

[0032] The pulp slurry used in the paper forming system 100 can be any suitable pulp slurry. In one embodiment, the pulp slurry includes wood fibers composed of wood cells that include cellulose, lignin, and hemicelluloses. Generally, the wood cells are assemblies of cellulose chains forming a framework that is encompassed by a hemicellulose matrix, and the lignin serves as an adhesive. Cellulose fibrils, which are smaller cellulose frameworks that combine to create cell walls, adhere to each other through hydrogen bonding. These fibrils assemble to create wood cells having several cell wall layers. The cell walls include a primary wall and three layers of secondary walls. The cell wall surrounds a hollow center, the lumen. The individual cells are held together by the lignin as well as by the middle lamella. The middle lamella is a conglomeration of hemicelluloses and lignin located between cells. The primary wall encompasses the secondary walls and separates it from the middle lamella. The secondary layer makes up the majority of the cell wall. To enter the lumen, molecules travel by diffusion through the cell wall or through larger holes that connect the outside of the cell to the interior (pits). Pits allow for the transport of water in the radial direction of the tree structure by connecting adjacent cells to each other through the middle lamellae. Once the cell is pulped, the pits allow for the impregnation of the fiber with various additives used in the process of forming paper. In most pulping processes, the middle lamella is destroyed and carried out by the pulping liquors from the resulting wood pulp.

[0033J] The wood fiber includes cellulose at about 50% to about 70% of the fiber content and lignin of about 25% to about 45% of the fiber, with the remaining portion of the fiber being made up of hemicelluloses and other wood polysaccharides. The majority of the lignin is found within the cell wall, with the surface of the fiber primarily including cellulose. The cellulose includes polymerized β -D-glucopyranoses in the 4C_1 chair confirmation joined by a β 1-4 glycosidic linkage. The linked chains are bound together through hydrogen bonding creating microfibrils which in turn form the walls of the cellulose fibers. The abundance of

- 8 -

hydroxyl groups creates many locations for hydrogen bonding. Hydrogen bonding facilitates interfiber bonding and enhances the formation of cellulosic products such as paper, providing their core strength. This versatile chemical framework also permits application of surface treatments in industrial production to adjust brightness and strength.

[0034] The slurry includes wood pulp formed by reducing raw wood to a slurry of wood fibers. This is accomplished by methodically destroying the bonds that hold the wood together, which may be achieved by chemical processes, mechanical processes, or a combination of the two. This forms carboxylic acid groups on the cellulose chains resulting in a negative surface charge. Different methods of pulping produce different quality pulps that contain varying proportions of the three wood cell components. In one embodiment, the pulp is formed by chemical pulping (for example, by the kraft process) and has corresponding concentration of cellulose, lignin, and hemicelluloses. Chemical pulping dissolves the middle lamella that holds the wood cells together. This dissolves the bonds holding the cells together and reacts away portions of the cellulose fiber, leading to lower pulp yields. The majority of lignin left in the chemical pulping processes is found within the cell walls. This residual lignin does not affect the ability of the fiber surface to hydrogen bond with adjacent fibers. A greater number of hydrogen bonds between adjacent fibers leads to a stronger final product. In another embodiment, the pulp is formed by mechanical pulping and has a corresponding concentration of cellulose, lignin, and hemicelluloses. In this embodiment, the pulp has a higher lignin content than chemical pulps due to the fact that mechanical pulping physically ruptures bonds between wood cells to create a fibrous mass.

[0035] In one embodiment, the pulp slurry is about 0.5% cellulose fibers and filler and about 99.5% water when it begins the sheet formation process. The water in the pulp slurry exists in the vicinity of the cellulose fibers as unbound water, freezing-bound water, and nonfreezing-bound water. The unbound water is water that is capable of being removed in the dewatering of the forming portions and/or pressing portions (further described below). The unbound water has a freezing temperature consistent with bulk water (about 0°C). The bound water, both freezing and nonfreezing, neighbor the fiber surface. As used herein, the phrase "nonfreezing-bound water" refers to the few layers of water adjacent to the fiber surface that due to the strong interfacial interaction are unable to undergo conformational rearrangements necessary to freeze. Stated another way, nonfreezing-bound water molecules have no freezing

- 9 -

temperature. As used herein, the phrase "freezing-bound water" refers to water which is bound to the nonfreezing-bound water and is adjacent to the bulk fluid. Freezing-bound water has a depressed freezing point due to its proximity to the nonfreezing-bound water. These types of water have been compartmentalized by differential scanning calorimetry and thermogravimetric analysis into two categories, easy-to-remove water and hard-to-remove water. As used herein, the phrase "easy-to-remove water" refers to free water and contains nearly all of the available unbound water (about 75% of the unbound water). As used herein, the phrase "hard-to-remove water" refers to trapped unbound water within the fiber walls (about 25% of the total unbound water) as well as all of the freezing and nonfreezing-bound waters. Hard-to-remove water accounts for about 30% to about 60% of the total water remaining in the sheet after pressing.

[0036] According to the disclosure, the pulp slurry is configured to provide additional dewatering during the forming portions and/or pressing portions through a non-mechanical mechanism. For example, in one embodiment, the pulp slurry includes a surface active agent or surfactant. In a further embodiment, the surfactant is a cationic surfactant. For example, the cationic surfactant can be cetyl trimethylammonium bromide ((C₁₆H₃₃)N(CH₃)₃Br) depicted below:

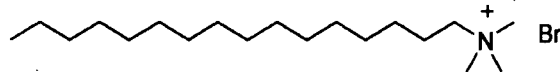

[0037] The pulping process generates several types of bonding sites on the wood fiber which can be used for surface modification. In addition to the native hydroxyl sites for hydrogen bonding, there are many carboxylic acid groups which form on the surface of the fibers during pulping. These groups can disassociate forming sites for electrostatic interactions. These electrostatic sites may be targeted for surface modifications, specifically by the surfactant. Additionally, interaction between the hydrophobic tail of the surfactant adsorbs to the cellulosic product.

[0038] Surfactants are organic compounds that are amphiphilic (i.e. they contain both hydrophobic groups, known as tails, and hydrophilic groups, known as heads). Due to their amphiphilic nature, surfactants are typically soluble in both organic solvents and water. The type of head group classifies surfactants as either anionic, cationic, non-ionic, or zwitterionic

- 10 -

(amphoteric), each of which may be used alone or in combination according to embodiments of the present disclosure. The amphiphilic nature of the surfactant leads to a driving force for the surfactant to migrate and adsorb or self-assemble at interfaces (e.g. air/liquid, liquid/liquid, and solid/liquid). At the liquid-gas interface (e.g. water-air), the surfactant acts to reduce the surface tension. Similarly, the surfactant can reduce the interfacial tension between two liquids by adsorbing at the liquid-liquid interface. Liquid-solid interfaces may also be modified by adsorption of the surfactant, leading, for example, to changes in surface energy, interfacial morphology, and the contact angle of liquids on the modified surface. Above a predetermined concentration, the surfactant assembles in bulk solution forming aggregates known as micelles. When micelles assemble in water, the hydrophobic tails of the surfactant create an inner core and the hydrophilic head groups form an outer shell that maintains favorable contact with water reducing the free energy.

[0039] In one embodiment, the surfactant modifies the surface of the cellulose fibers through the process of self-assembly. The adsorption of the surfactant on a cellulose surface is classified as self-assembly. Electrostatic forces and the hydrophilic nature of the surfactant and the cellulose fiber provide non-covalent contributions to the bonding. The alkyl chain of the surfactant contributes additional driving forces for adsorption.

[0040] As discussed above, the surface of the wood fiber includes cellulose and carboxylic acid groups formed by pulping. The carboxylic acid groups provide electrostatic bonding sites. This allows for adsorption of various hydrophilic head groups of the surfactant. Adsorbing a cationic surfactant onto the cellulose surface creates an increase in the zeta potential of the cellulose. The zeta potential is an electric potential in the interfacial double layer at the slipping plane versus a point in the bulk fluid away from the colloidal interface. That is, zeta potential is the potential difference between the dispersion medium and the stationary layer of fluid attached to the surface. The dispersion medium in the pulp slurry is the water surrounding the cellulose fibers and the stationary layer of fluid is bound water on the fiber. The change in surface energy associated with the cellulose fiber changes the behavior of cellulose surface interactions (e.g. fiber-fiber, fiber-water, etc.).

[0041] The surfactant can have any suitable chain length. Chain lengths can be C12, C14, C16, C18, or any other suitable chain length. Adsorption isotherms of cationic surfactants with

- 11 -

varying alkyl chain lengths on cellulose surfaces show the dependence of adsorption on the chain length. Increasing surfactant chain length leads to a shift of adsorption toward lower concentrations and to a continuous increase in the maximum adsorbed amount of surfactant. This trend is attributed to the entropic driving forces derived from the hydrophobic surfactant tails.

[0042] In one embodiment, the wood pulp is chemically modified to enhance pulp qualities due to the reuse and recycling of paper in the wood pulp. While some properties of a recycled pulp can be improved by chemical treatments, other aspects of the pulp are negatively affected. Recycled pulp treated with butylamine and ammonia results in lower hydroxyl contents. The water holding capacity decreases after the treatment; however, the pulps also decrease in tensile strength. The reduction in the number of hydrogen bonding sites (hydroxyl groups) is believed to decrease fiber-fiber bonding strength, as evidenced by the lower tensile strength, and to lead to the decrease in water holding capacity due to a reduction in hydrophilicity of the fiber surfaces.

[0043] In one embodiment, the pulp slurry reduces the hydraulic force for exceeding capillary force holding water within the fiber within the lumen and between fibers through the reduction of the capillary force itself. Parameters governing the water removal from capillaries within the fiber within the lumen and between the fibers are given by the Young-Laplace equation and are the water-air surface tension, the cellulose-water contact angle, and the pore radius.

$$\Delta P = \frac{2 \cdot \gamma_{lg} \cdot \cos(\theta_{ls})}{r} \quad (1)$$

- 12 -

[0044] Where ΔP is the pressure difference across the liquid-gas (water-air) interface, γ_{lg} is the liquid-gas (water-air) surface tension, θ_{lg} is the solid-liquid (fiber-water) contact angle, and r is the capillary radius. Surfactants adsorb on cellulose (cationic surfactants in particular) and hence affect the surface energy and potential and consequent contact angle. Additionally, surfactants modify the water-air surface tension and/or changes in pore radii.

[0045] In one embodiment, surfactants are added in the pulping process of recycled fiber (printed and/or unprinted), virgin fiber, or a combination thereof. The recycled fiber exhibits a larger water holding capacity than the virgin fiber due to its level of fiber destruction through repeated processing. In one embodiment, the virgin fiber is 85% softwood and 15% hardwood kraft mix commonly used in paper making.

EXAMPLES

[0046] Water retention value (WRV) is a laboratory scale comparative measure of water content in a paper mat after the pressing portion. The test involves a 40 g sample of pulp centrifuged at 900 G for 30 minutes. After the 30 minutes, the sample is weighed. The sample is subsequently oven dried for a minimum of 12 hours, and reweighed. The WRV is calculated by the following equation:

$$WRV = \frac{\text{Weight of Pad after Centrifuging} - \text{Weight of Oven Dried Pad}}{\text{Weight of Oven Dried Pad}} \quad (2)$$

[0047] The water retention value test may be modified to model different water removal conditions for specific forming and pressing conditions. A reduction in the WRV translates into a decrease in the water load entering the dryer section.

EXAMPLE 1

[0048] In a first example, a sample was prepared by pulping 40 grams of unprinted fiber in one liter of tap water (at about 50 to about 60°C) in a disintegrator to form a 4% (by wet weight) pulp slurry. The surfactant cetyl trimethylammonium bromide ($(C_{16}H_{33})N(CH_3)_3Br$) (or CTAB) was added at the commencement of the pulping process. WRV was analyzed in comparison to the amount of surfactant during a 7 minute pulp time employing unprinted recycled paper. The quantities of the surfactant tested were 0% (control), 0.35%, 0.70%, 1.0%,

- 13 -

1.75%, and 3.5% (by weight % of the fiber). In general, as shown in FIG. 2, as the amount of surfactant increased, the WRV decreased. At an amount of 1% surfactant, WRV decreased over 20%.

EXAMPLE 2

[0049] In a second example, a sample was prepared by pulping 40 grams of printed fiber in one liter of tap water (at about 50 to about 60°C) in a disintegrator to form a 4% pulp slurry (by wet weight). The surfactant CTAB was added at the commencement of the pulping process. WRV was analyzed in comparison to the amount of surfactant during a 7 minute pulp time employing printed recycled paper. The quantities of the surfactant tested were 0.0% (control), 0.35%, 0.70%, and 1.0% (by weight % of the fiber). As shown in FIG. 3, the WRV decreased. However, it is believed that the ionic components of printed paper (for example, ink) complexed with the cationic surfactant reducing the surfactant's effectiveness at lowering the WRV relative to that found in Example 1. Pulping time was varied from 7, 10, 15 to 30 minutes with no changes in the WRV noted.

EXAMPLE 3

[0050] In a third example, a sample was prepared by pulping 40 grams of fiber in one liter of tap water (at about 50 to about 60°C) in a disintegrator to form a 4% pulp slurry (by wet weight). Sodium dodecyl sulfate (SDS) (an anionic surfactant) was added at the commencement of the pulping process. WRV was analyzed in comparison to the amount of surfactant during a 7 minute pulp time employing unprinted recycled paper. The quantities of the surfactant tested were 0.35%, 0.70%, and 1.0% (by weight % of the fiber). As shown in FIG. 4, surface tension was decreased in comparison to a control (Control 1). As shown in FIG. 5, WRV was decreased in comparison to a control (Control 2).

EXAMPLE 4

[0051] In a fourth example, a sample was prepared by pulping 40 grams of fiber in one liter of tap water (at about 50 to about 60°C) in a disintegrator to form a 4% pulp slurry (by wet weight). Lignosulfonic acid (an anionic surfactant) was added at the commencement of the pulping process. WRV was analyzed in comparison to the amount of surfactant during a 7 minute pulp time employing unprinted recycled paper. The quantities of the surfactant tested

- 14 -

were 0.35% and 1.0% (by weight % of the fiber). As shown in FIG. 4, surface tension was decreased in comparison to a control (Control 1). As shown in FIG. 5, WRV was not decreased in comparison to a control (Control 2).

EXAMPLE 5

[0052] In a fifth example, a sample was prepared by pulping 40 grams of fiber in one liter of tap water (at about 50 to about 60°C) in a disintegrator to form a 4% pulp slurry (by wet weight). Triton X-100 (a non-ionic surfactant) was added at the commencement of the pulping process. WRV was analyzed in comparison to the amount of surfactant during a 7 minute pulp time employing unprinted recycled paper. The quantities of the surfactant tested were 0.35%, 0.70%, and 1.0% (by weight % of the fiber). As shown in FIG. 4, surface tension was decreased in comparison to a control (Control 1). As shown in FIG. 5, WRV was decreased in comparison to a control (Control 2).

EXAMPLE 6

[0053] In a sixth example (a comparative example), a sample was prepared by pulping 40 grams of fiber in one liter of tap water (at about 50 to about 60°C) in a disintegrator to form a 4% pulp slurry (by wet weight). Percol 182 (a cationic polymer) was added at the commencement of the pulping process. WRV was analyzed in comparison to the amount of the cationic polymer during a 7 minute pulp time employing unprinted recycled paper. The quantities of the cationic polymer tested were 0.35%, 0.70%, and 1.0% (by weight % of the fiber). As shown in FIG. 4, surface tension was not decreased in comparison to a control (Control 1). As shown in FIG. 5, WRV was decreased in comparison to a control (Control 2) for quantities of 0.70% and 1.0%.

EXAMPLE 7

[0054] In a seventh example, (another comparative example), a sample was prepared by pulping 40 grams of fiber in one liter of tap water (at about 50 to about 60°C) in a disintegrator to form a 4% pulp slurry (by wet weight). Aerosol 380 (a colloidal silica) was added at the commencement of the pulping process. WRV was analyzed in comparison to the amount of the colloidal silica during a 7 minute pulp time employing unprinted recycled paper. The quantities of the silica tested were 0.35%, 0.70%, and 1.0% (by weight % of the

- 15 -

fiber). As shown in FIG. 4, surface tension was barely decreased in comparison to a control (Control 1). As shown in FIG. 5, WRV was decreased in comparison to a control (Control 2) for quantities of 0.70% and 1.0%.

[0055] In sum, all four surfactants (SDS, Triton X-100, CTAB, and lignosulfonic acid) showed decreases in the surface tension in comparison to Control 1. The examples suggest that the degree of the decrease was a function of quantity. The variation of the quantities showed a decrease in quantity dependency between SDS, Triton X-100, CTAB, and lignosulfonic acid. CTAB, SDS, and Triton X-100 showed notable decreases in WRV. The degree of effectiveness as a function of quantity decreases from CTAB, to SDS, to Triton X-100.

EXAMPLE 8

[0056] In an eighth example, a sample was prepared by adding CTAB during pulping at about 1 wt% (2=1wt%CTAB). As shown in FIGS. 6 and 7, WRV and surface tension of a control (1=Control) with recycled directory pulp were measured. The data (including error calculations) was used for comparison to embodiments of the present disclosure and for comparison to comparative examples as explained in Examples 9 through 11.

EXAMPLE 9

[0057] In a ninth example, a sample was prepared by adding Ciba's Teiioform retention system (now available through BASF) under a high shear mixing environment (3=Ciba MP system) and added it to the pulp slurry. Ciba's Teiioform retention system includes Ciba Percol, Ciba Hydrocol, Ciba Alcofix, and Ciba Teiioform. As shown in FIGS. 6 and 7, WRV and surface tension were measured. As shown in FIG. 6, WRV was substantially similar in comparison to the control (1=Control) but higher than the CTAB (2=1wt%CTAB). As shown in FIG. 7, surface tension was substantially unchanged in comparison to the control (1=Control) but higher than the CTAB (2=1wt%CTAB).

EXAMPLE 10

[0058] In a tenth example, a sample was prepared by adding the Ciba Teiioform retention system to a batch of pulp previously treated with 1 wt% CTAB (4=CTAB then CIBA). As

- 16 -

shown in FIGS. 6 and 7, WRV and surface tension were measured. As shown in FIG. 6, WRV was decreased in comparison to the control (1=Control), substantially similar to the CTAB (2=1 wt%CTAB), and decreased in comparison to the Ciba Telioform retention System (3=Ciba MP system). As shown in FIG. 7, surface tension was decreased in comparison to the control (1=Control), slightly higher than the CTAB (2=1 wt%CTAB), and decreased in comparison to the Ciba Telioform System (3=Ciba MP system).

EXAMPLE 11

[0059] In an eleventh example, a sample was prepared by adding 1 wt% CTAB to a pulp already prepared with the Ciba Telioform retention system (5=CIBA then CTAB). As shown in FIGS. 6 and 7, WRV and surface tension were measured. As shown in FIG. 6, WRV was decreased in comparison to the control (1=Control), substantially similar to the CTAB (2=1wt%CTAB), decreased in comparison to the Ciba Telioform retention system (3=Ciba MP system), and slightly above the Ciba Telioform system with 1 wt% CTAB added (4=CTAB then CIBA). As shown in FIG. 7, surface tension was decreased in comparison to the control (1=Control), slightly higher than the CTAB (2=1 wt%CTAB), decreased in comparison to the Ciba Telioform retention system (3=Ciba MP system), and substantially the same as the Ciba Telioform retention system with 1 wt% CTAB added (4=CTAB then CIBA).

EXAMPLE 12

[0060] In a twelfth example, a pulp was prepared to make paper. The pulp was stored in mixing tanks overnight. A fourdrinier paper machine was used for making the paper. Then, CTAB was added at about 1.0%. The CTAB was introduced directly to the pulp in the mixing tank rather than during the pulping process. Product specifications were a 74 g/m² basis weight with about 5% sheet moisture upon input. The trial was run for one day, individual conditions were run at steady state for about 45 minutes. Steam pressure, pressing force, and forming section vacuum settings were kept constant. Furnish freeness was verified at the beginning of each run. Head box samples were taken every 20 minutes to collect data on pH and also to perform a Mutek charge potential. Product samples were gathered after a couch, a second press, and at a machine reel to determine water content at each portion of the process. A portion of the sample was dried on a hot plate for an immediate sheet solids number to provide a guide, and three additional samples were placed in a 105°C oven over night for final

- 17 -

sheet solids. Paper was also collected from the reel to provide samples for sheet strength and other sheet property testing. A 2.5% solids increase after the forming portion was noted. A 1.25% solids increase after the pressing portion was noted. A 2% increase in reel solids was noted.

[0061] While the invention has been described with reference to a preferred embodiment, it will be understood by those skilled in the art that various changes may be made and equivalents may be substituted for elements thereof without departing from the scope of the invention. In addition, many modifications may be made to adapt a particular situation or material to the teachings of the invention without departing from the essential scope thereof. For example, ranges, relationships, quantities, and comparisons between aspects of the disclosure (including the Examples and the Figures) are included within the scope of the invention. Therefore, it is intended that the invention not be limited to the particular embodiment disclosed as the best mode contemplated for carrying out this invention, but that the invention will include all embodiments falling within the scope of the appended claims.

CLAIMS

1. A wet form cellulosic product forming process, the process comprising:
 - providing a slurry;
 - forming the slurry into a cellulosic product;
 - dewatering the cellulosic product; and
 - drying the cellulosic product;wherein the cellulosic product is further dewatered through a non-mechanical mechanism, the non-mechanical mechanism being provided by a soluble surfactant selected from the group consisting of a cationic surfactant, an anionic surfactant, a nonionic surfactant, a zwitterionic surfactant, and combinations thereof.
2. The process of claim 1, wherein the dewatering of the cellulosic product includes pressing the cellulosic product.
3. The process of claim 1, wherein the slurry includes the cationic surfactant.
4. The process of claim 3, wherein the cationic surfactant has a 12-Carbon chain.
5. The process of claim 3, wherein the cationic surfactant has a 14-Carbon chain.
6. The process of claim 3, wherein the cationic surfactant has a 16-Carbon chain.
7. The process of claim 3, wherein the cationic surfactant has a 18-Carbon chain.
8. The process of claim 1, wherein the slurry includes the anionic surfactant.
9. The process of claim 1, wherein the slurry includes the nonionic surfactant.
10. The process of claim 1, wherein the slurry includes the zwitterionic surfactant.
11. The process of claim 1, wherein the soluble surfactant is cetyl trimethylammonium bromide ((C₁₆H₃₃)N(CH₃)₃Br).

- 19 -

12. The process of claim 1, wherein the soluble surfactant adsorbs on or within cellulosic fibers within the slurry.
13. The process of claim 1, wherein the non-mechanical mechanism increases concentration of solids beyond what is capable through mechanical mechanisms without damaging the cellulosic product.
14. The process of claim 1, wherein the non-mechanical mechanism reduces a hydraulic force correlating to a capillary force retaining water within or between a fiber of cellulose within the slurry.
- 15. The process of claim 1, wherein the non-mechanical mechanism increases concentration of solids in the cellulosic product by at least about 1% solids.
16. The process of claim 1, wherein the forming of the cellulosic product and the pressing of the cellulosic product dewater the cellulosic product through a non-mechanical mechanism.
17. The process of claim 1, wherein the cellulosic product is paper.
18. The process of claim 1, wherein the cellulosic product is ceiling board.
19. A wet formed cellulosic product forming process, the process comprising:
 - providing a slurry;
 - forming a cellulosic product from the slurry;
 - pressing the cellulosic product to dewater the cellulosic product; and
 - drying the cellulosic product;wherein the cellulosic product is further dewatered through a non-mechanical mechanism during the forming and the pressing of the cellulosic product.
20. A wet formed cellulosic product, the product comprising cetyl trimethylammonium bromide ((C₁₆H₃₃)N(CH₃)₃Br).
21. The product of claim 19, wherein the wet formed cellulosic product is selected from the group consisting of paper and ceiling board.

REPLACEMENT SHEET 1/4

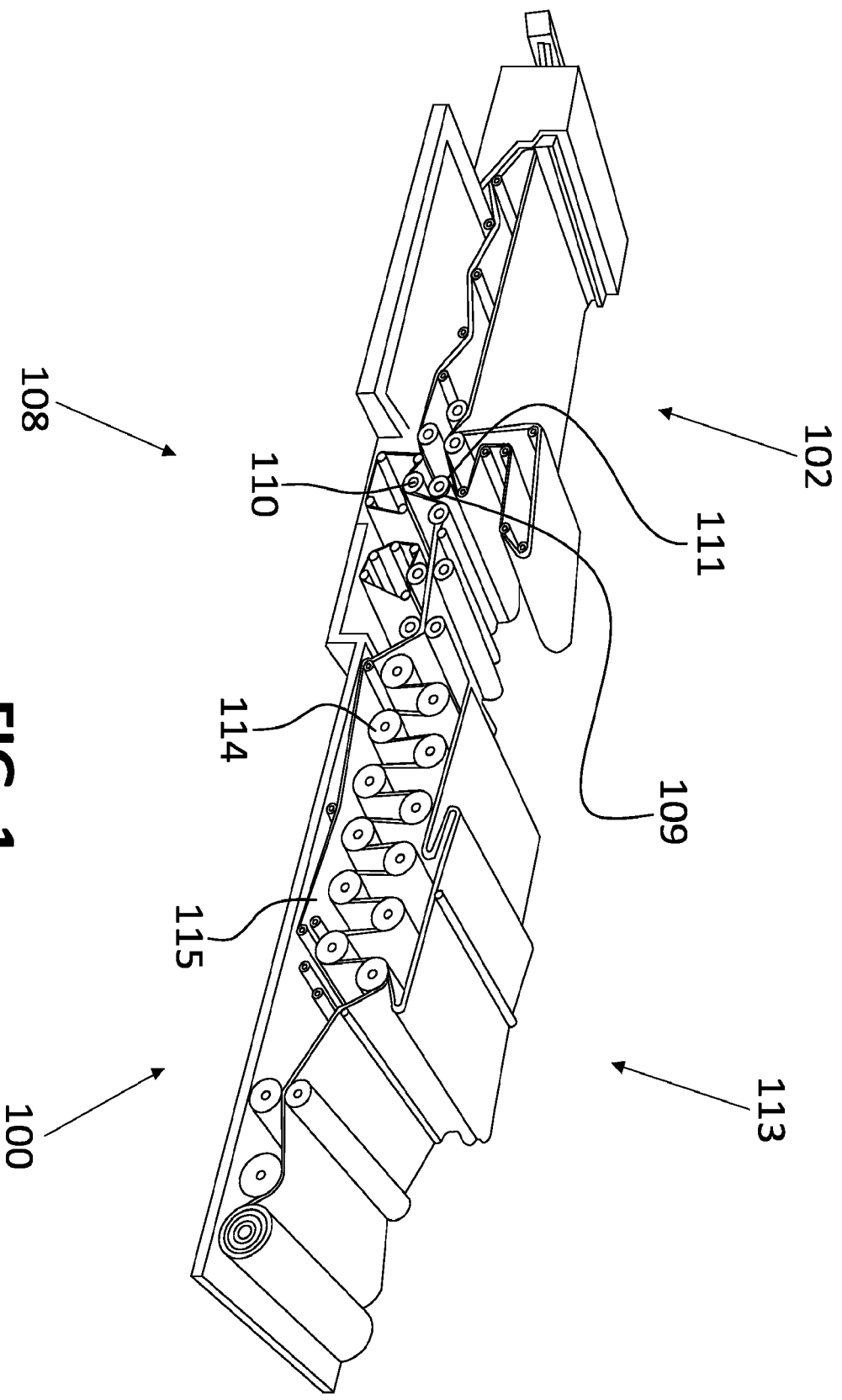

FIG. 1

REPLACEMENT SHEET 2/4

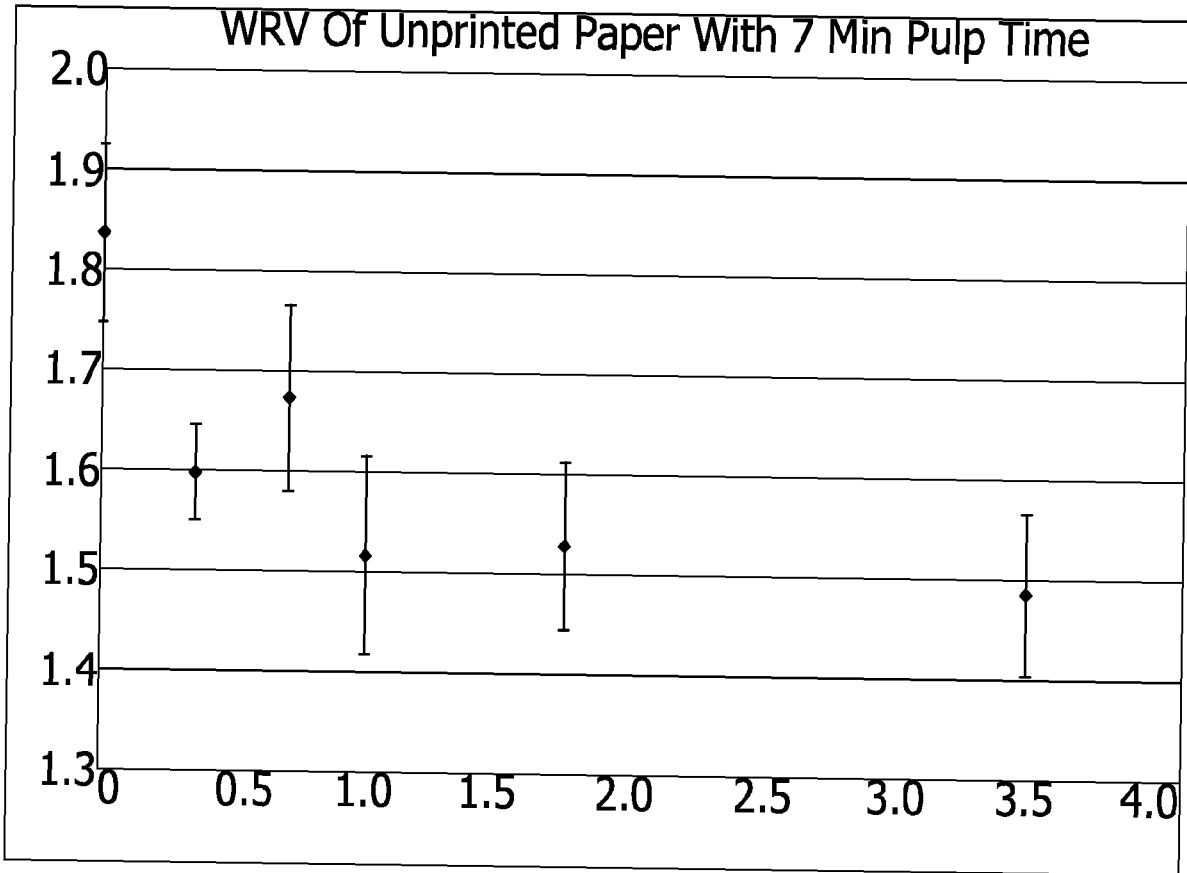

FIG. 2

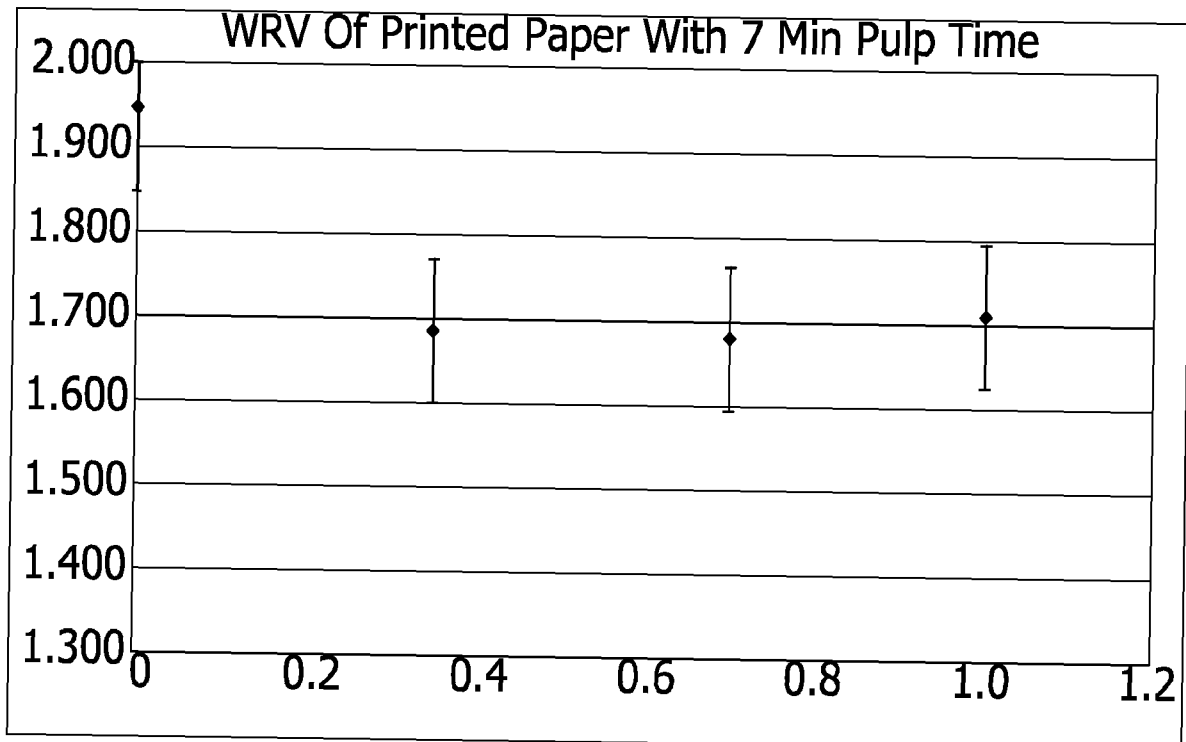
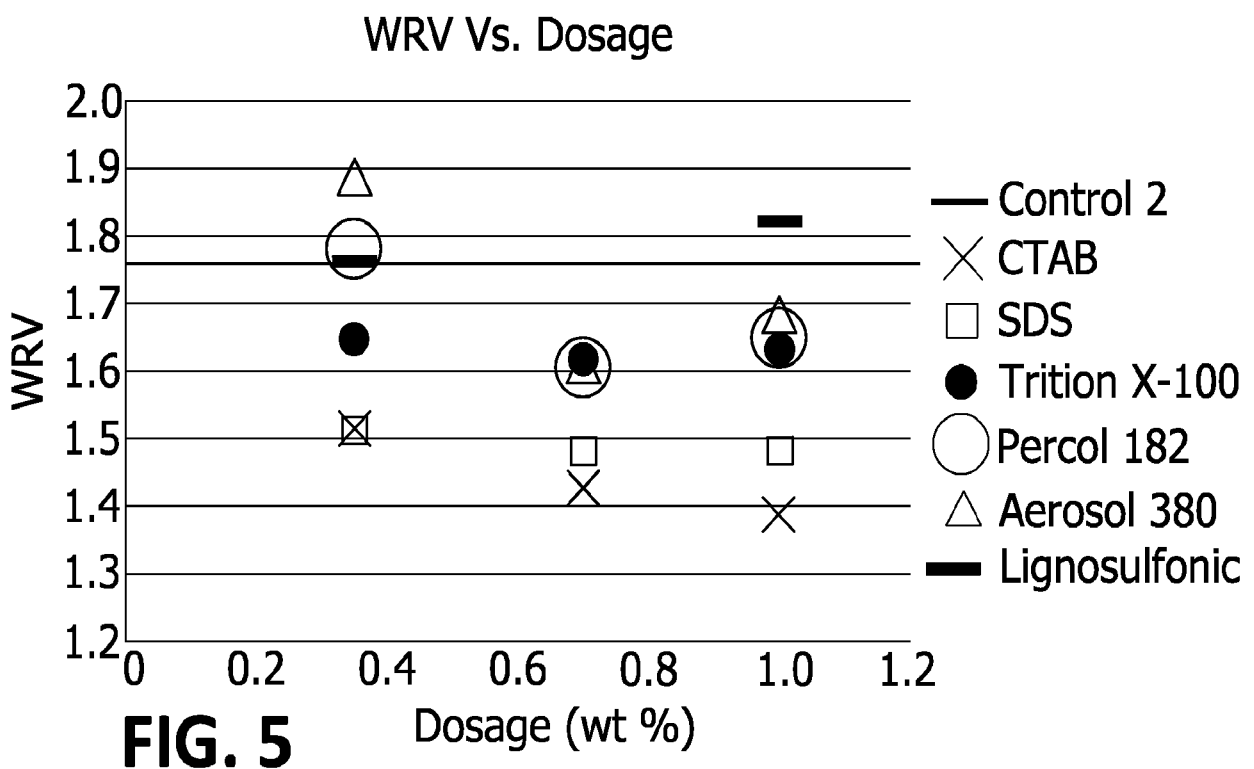
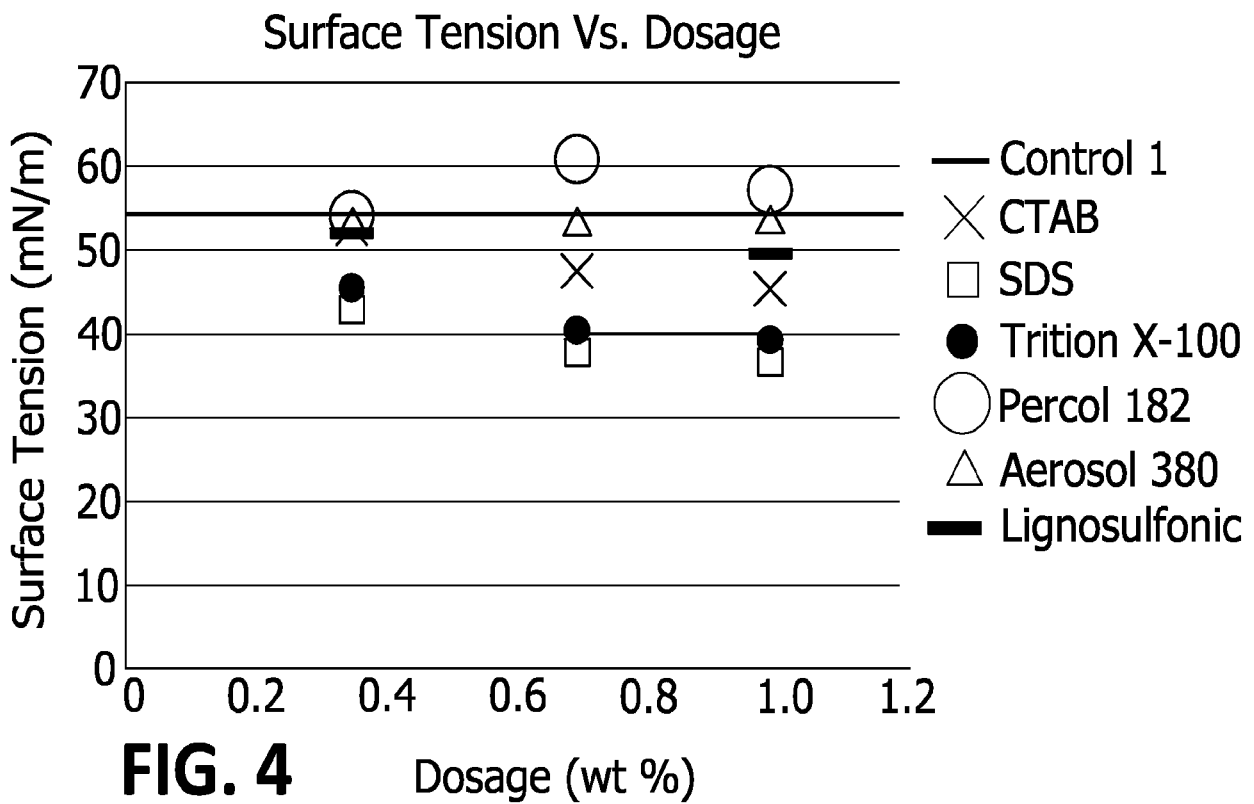
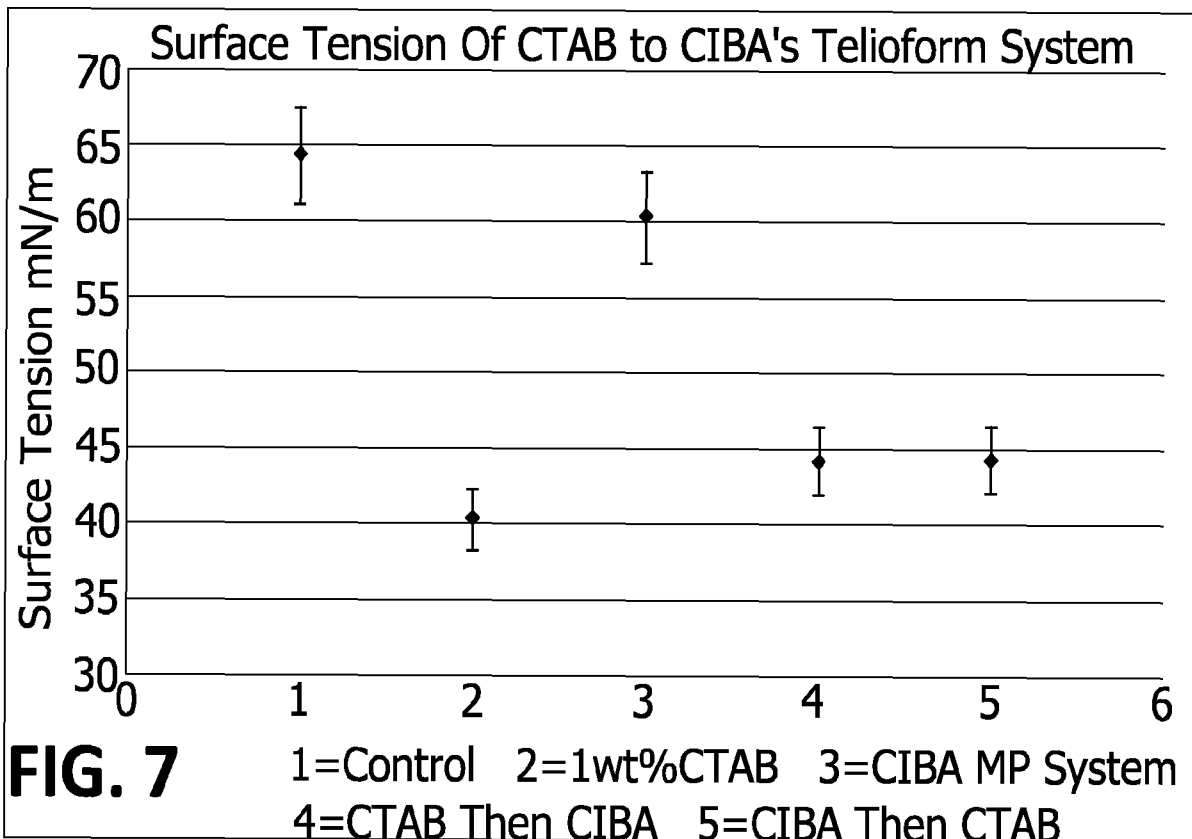
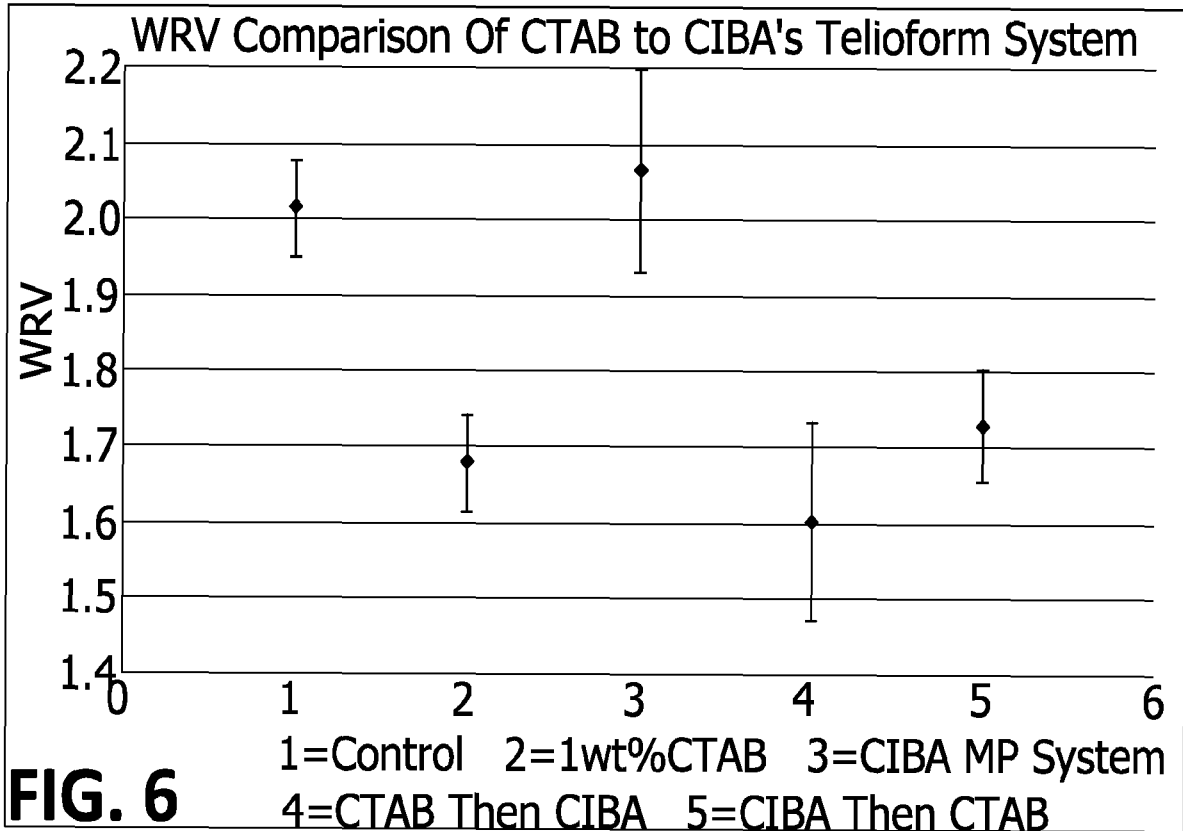

FIG. 3

REPLACEMENT SHEET 3/4



REPLACEMENT SHEET 4/4



INTERNATIONAL SEARCH REPORT

International application No
PCT/US2010/047560

A. CLASSIFICATION OF SUBJECT MATTER INV. D21H21/24 ADD.				
According to International Patent Classification (IPC) or b both national classification and IPC				
B. FIELDS SEARCHED Minimum documentation searched (classification system followed by classification symbols) D21H				
Documentation searched other than minimum documentation to the extent that such documents are included in the fields searched				
Electronic data base consulted during the international search (name of data base and, where practical, search terms used) EPO-Internal				
C. DOCUMENTS CONSIDERED TO BE RELEVANT				
Category*	Citation of document, with indication, where appropriate, of the relevant passages	Relevant to claim No.		
X	WO 03/106766 A1 (ONDEO NALCO CO [US]) 24 December 2003 (2003-12-24) claims 1-10; examples 1-3 -----	1,2, 12-19,21		
X	US 4 062 721 A (GUYER VERNON L ET AL) 13 December 1977 (1977-12-13) claims 1-6 -----	1,17,19, 21,212		
X	WO 00/63487 A1 (KIMBERLY CLARK CO [US]) 26 October 2000 (2000-10-26) claims 1-17 -----	17		
X	EP 1 375 736 A1 (WEYERHAEUSER CO [US]) 2 January 2004 (2004-01-02) paragraphs [0024], [0070]; claim 1 ----- -/~	17		
<table style="width: 100%; border: none;"> <tr> <td style="width: 50%; border: none;"> <input checked="" type="checkbox"/> Further documents are listed in the continuation of Box C. </td> <td style="width: 50%; border: none;"> <input checked="" type="checkbox"/> See patent family annex. </td> </tr> </table>			<input checked="" type="checkbox"/> Further documents are listed in the continuation of Box C.	<input checked="" type="checkbox"/> See patent family annex.
<input checked="" type="checkbox"/> Further documents are listed in the continuation of Box C.	<input checked="" type="checkbox"/> See patent family annex.			
* Special categories of cited documents :				
"A" document defining the general state of the art which is not considered to be of particular relevance "E" earlier document but published on or after the international filing date "L" document which may throw doubts on priority claim(s) or which is cited to establish the publication date of another citation or other special reason (as specified) "O" document referring to an oral disclosure, use, exhibition or other means "P" document published prior to the international filing date but later than the priority date claimed	"T" later document published after the international filing date or priority date and not in conflict with the application but cited to understand the principle or theory underlying the invention "X" document of particular relevance; the claimed invention cannot be considered novel or cannot be considered to involve an inventive step when the document is taken alone "Y" document of particular relevance; the claimed invention cannot be considered to involve an inventive step when the document is combined with one or more other such documents, such combination being obvious to a person skilled in the art. "&" document member of the same patent family			
Date of the actual completion of the international search 9 November 2010	Date of mailing of the international search report 17/11/2010			
Name and mailing address of the ISA/ European Patent Office, P.B. 5818 Patentlaan 2 NL - 2280 HV Rijswijk Tel. (+31-70) 340-2040, Fax: (+31-70) 340-3016	Authorized officer Karlsson, Lennart			

INTERNATIONAL SEARCH REPORT

International application No

PCT/US2010/047560

C(Continuation). DOCUMENTS CONSIDERED TO BE RELEVANT		
Category*	Citation of document, with indication, where appropriate, of the relevant passages	Relevant to claim No.
X	EP 1 113 107 A2 (KAO CORP [JP]) 4 July 2001 (2001-07-04) claims 1,2; example 1 -----	17
A	US 2007/169904 A1 (NGUYEN DUY T [US]) 26 July 2007 (2007-07-26) the whole document -----	1-21
A	EP 2 093 278 A1 (EVONIK GOLDSCHMIDT GMBH [DE]) 26 August 2009 (2009-08-26) the whole document -----	1-21
A	EP 0 495 430 A1 (CANON KK [JP]) 22 July 1992 (1992-07-22) the whole document -----	1-21

INTERNATIONAL SEARCH REPORT

Information on patent family members

International application No

PCT/US2010/047560

Patent document cited in search report		Publication date	Patent family member(s)		Publication date
wo 03106766	AI	24-12-2003	AU	2003233418	AI 31-12-2003
			CN	1662705	A 31-08-2005
			EP	1552055	AI 13-07-2005
			JP	4346547	B2 21-10-2009
			JP	2005530054	T 06-10-2005
			US	6706144	BI 16-03-2004
US 4062721	A	13-12-1977	NONE		
wo 0063487	AI	26-10-2000	AU	4356700	A 02-11-2000
			BR	0009807	A 26-11-2002
			CN	1354810	A 19-06-2002
			EP	1175528	AI 30-01-2002
			JP	2003529681	T 07-10-2003
			KR	20020003562	A 12-01-2002
			MX	PA01010451	A 18-09-2002
			PL	366308	AI 24-01-2005
			TR	200102990	T2 21-10-2002
			EP 1375736	AI	02-01-2004
US	2005086828	AI 28-04-2005			
EP 1113107	A2	04-07-2001	CA	2329557	AI 24-06-2001
			DE	60034419	T2 03-01-2008
			ES	2284446	T3 16-11-2007
			JP	3810986	B2 16-08-2006
			JP	2001248100	A 14-09-2001
			US	2002117278	AI 29-08-2002
US 2007169904	AI	26-07-2007	NONE		
EP 2093278	AI	26-08-2009	CA	2652704	AI 05-08-2009
			CN	101502770	A 12-08-2009
			JP	2009185287	A 20-08-2009
			US	2010029519	AI 04-02-2010
EP 0495430	AI	22-07-1992	AT	132809	T 15-01-1996
			AU	657941	B2 30-03-1995
			AU	1024092	A 16-07-1992
			CA	2059207	AI 15-07-1992
			DE	69207438	DI 22-02-1996
			DE	69207438	T2 20-06-1996
			US	5338597	A 16-08-1994