

(19) AUSTRALIAN PATENT OFFICE

(54) Title
Otosopic tip element and related method of use

(51)⁶ International Patent Classification(s)
A61B 1/227 (2006.01) 20060101AFI2005100
A61B 1/227 8BMEP
PCT/US2004/024008

(21) Application No: 2004264876 (22) Application Date: 2004 .07 .26

(87) WIPO No: W005/016117

(30) Priority Data

(31) Number	(32) Date	(33) Country
60/543,858	2004 .02 .11	US
60/490,566	2003 .07 .28	US
60/507,473	2003 .09 .30	US
10/897,455	2004 .07 .23	US

(43) Publication Date : 2005 .02 .24

(71) Applicant(s)
Welch Allyn, Inc.

(72) Inventor(s)
Bausch, Michael E.; Strom, John R.; Roberts, Chris R.; Woods, David; Krauter, Allan I.;
Kuiper, Cynthia A.; Andreassen, Eric M.

(74) Agent/Attorney
Shelston IP, Level 21 60 Margaret Street, Sydney, NSW, 2000

(56) Related Art
US 6190310
US 2003/0063386
US 6106457
US 6213938

CORRECTED VERSION

(19) World Intellectual Property
Organization
International Bureau



(43) International Publication Date
24 February 2005 (24.02.2005)

PCT

(10) International Publication Number
WO 2005/016117 A3

- (51) International Patent Classification⁷: A61B 1/227
- (21) International Application Number: PCT/US2004/024008
- (22) International Filing Date: 26 July 2004 (26.07.2004)
- (25) Filing Language: English
- (26) Publication Language: English
- (30) Priority Data:
60/490,556 28 July 2003 (28.07.2003) US
60/507,473 30 September 2003 (30.09.2003) US
60/543,858 11 February 2004 (11.02.2004) US
10/897,455 23 July 2004 (23.07.2004) US
- (71) Applicant: WELCH ALLYN, INC. [US/US]; 4341 State Street Road, Skaneateles Falls, New York 13153 (US).
- (71) Applicants and
(72) Inventors: STROM, John R. [US/US]; 387 Fire Lane 30, Moravia, New York 13118 (US). KUIPER, Cynthia A. [US/US]; 4212 Wolf Hollow Road, Syracuse, New York 13219 (US). ROBERTS, Chris R. [US/US]; 740 Sheldon Road, Skaneateles, New York 13152 (US). BAUSCH, Michael E. [US/US]; 6995 Coy Road, Lovonia, New York 14487 (US). KRAUTER, Allan I. [US/US]; 2224 West Lake Road, Skaneateles, New York 13152 (US). ANDREASSEN, Eric M. [US/US]; 4460 Milton Avenue, Camillus, New York 13031 (US). WOODS, David [US/US]; 456 Sprague Road, Memphis, New York 13112 (US).
- (74) Agent: BILINSKI, Peter J.; Wall Marjama & Bilinski LLP, 101 South Salina Street, Syracuse, New York 13202 (US).
- (81) Designated States (unless otherwise indicated, for every kind of national protection available): AE, AG, AL, AM, AT, AU, AZ, BA, BB, BG, BR, BW, BY, BZ, CA, CH, CN, CO, CR, CU, CZ, DE, DK, DM, DZ, EC, EE, EG, ES, FI, GB, GD, GE, GH, GM, HR, HU, ID, IL, IN, IS, JP, KE, KG, KP, KR, KZ, LC, LK, LR, LS, LT, LU, LV, MA, MD, MG, MK, MN, MW, MX, MZ, NA, NI, NO, NZ, OM, PG, PH, PL, PT, RO, RU, SC, SD, SE, SG, SK, SL, SY, TJ, TM, TN, TR, TT, TZ, UA, UG, US, UZ, VC, VN, YU, ZA, ZM, ZW.
- (84) Designated States (unless otherwise indicated, for every kind of regional protection available): ARIPO (BW, GH, GM, KE, LS, MW, MZ, NA, SD, SI, SZ, TZ, UG, ZM, ZW), Eurasian (AM, AZ, BY, KG, KZ, MD, RU, TJ, TM), European (AT, BE, BG, CH, CY, CZ, DE, DK, EE, ES, FI, FR, GB, GR, HU, IE, IT, LI, LU, MC, NL, PL, PT, RO, SI, SK, TR), OAPI (BF, BJ, CF, CG, CI, CM, GA, GN, GQ, GW, ML, MR, NE, SN, TD, TG).
- Published:
— with international search report
- (88) Date of publication of the international search report: 6 May 2005
- (48) Date of publication of this corrected version: 2 June 2005

[Continued on next page]

(54) Title: OTOSCOPIC TIP ELEMENT AND RELATED METHOD OF USE

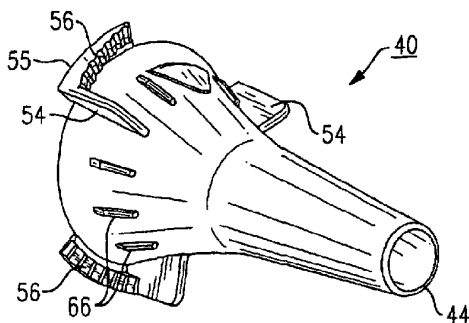

(57) Abstract: A tip element for an otoscopic apparatus includes engagement features that permit selective attachment to two different tip attachment mechanisms. The tip element includes both interior and exterior engagement features that provide interchangeability with otoscopes having different tip attachment schemes. The tip element includes an increased distal aperture formed from a decreased slope that enables a larger field of view, permitting the entire tympanic membrane to be viewed at once. External engagement features permit ejection of the tip from the otoscope, as well as stackability of a plurality of tip elements.

WO 2005/016117 A3



(15) Information about Correction:

see PCT Gazette No. 22/2005 of 2 June 2005, Section II

For two-letter codes and other abbreviations, refer to the "Guidance Notes on Codes and Abbreviations" appearing at the beginning of each regular issue of the PCT Gazette.

OTOSCOPIC TIP ELEMENT AND RELATED METHOD OF USE**Field of the Invention**

This invention relates generally to the field of otoscopy and in particular to an improved otoscopic instrument and at least one improved releasably attachable tip element for use with otoscopic apparatus.

Background of the Invention

Otoscopes are hand-held instruments that are commonly known in the medical diagnostic instrument field by practitioners and health care providers primarily for examining the ear, including the tympanic membrane, of a patient.

Any discussion of the prior art throughout the specification should in no way be considered as an admission that such prior art is widely known or forms part of common general knowledge in the field.

A typical otoscope is capable of being held in the hand of a practitioner and includes an instrument head having a distal frusto-conical insertion portion that permits overlying attachment of a disposable speculum tip. The disposable speculum tip is also preferably designed with a frusto-conical configuration to permit insertion to only an appropriate distance into the ear canal of the patient. Commonly, a ringlet of optical fibers encircles the tip opening of the insertion portion so as not to impede with the user's visualization of the target, the fibers extending from a contained light source, such as a miniature incandescent lamp or bulb, that is housed within the instrument handle or a neck portion of the instrument head. The target (e.g., the tympanic membrane) is then viewed via a lens located in the proximal end of the instrument head, the lens being aligned optically with the distal tip opening of the insertion portion to permit user viewing. Often, the lens magnifies the view of the target.

Alternatively, a video camera or at least one solid state imaging element, such as a CCD-or CMOS-based imager, can be used to view the target in lieu of the lens, the image as processed being transmitted to a video monitor for display. In addition, the instrument head can include a receiving port for a pneumatic bulb, permitting insufflation (e.g., pneumatic otoscopy). These devices can also be used, in some instances, for examining the nose and throat in addition to the ear and ear canal, as well as to provide a general illumination and magnification system.

There are a number of perceived needs in the field currently. When considering the basic functions of the otoscope; e.g., visualization of the tympanic membrane, there

have been expressed needs to increase the field of view and to provide greater magnification thereof, in addition to eye relief. Eye relief is practically defined as the distance between the most proximal optic of the instrument (e.g. the optic closest to the practitioner's eye) and the practitioner/user's eye when the full field is viewed.

- 5 Magnification and eye relief are interrelated such that having an image overly magnified will bring the image "closer" to the eye of the practitioner, etc. Current otoscopes, due to the tortuous construction of the ear canal and the lenses that are used therein, cannot fit the entire tympanic membrane into the field of view.

To provide all of these noted improvements, in general, requires a tradeoff in
10 depth of field, since optically all of the above factors are related. For example, the consequence of a depth of field loss is that for some patients with either long or short ear canals (as compared to a so-called "standard" or nominal ear canal), the tympanic membrane would no longer be in focus. This lack of focus is a distinct disadvantage and would seriously impact the practitioner's ability to give proper care.

15 There is yet another need generally in the field to be able to perform different diagnostic procedures as part of a comprehensive otoscopic examination. This need places increasing demands and constraints upon releasably attached disposable speculum tips used with the apparatus, in order to maintain cleanliness and prevent cross-contamination. A brief list of the requirements that are attributed to these type of
20 otoscope tips include the following:

- i) to achieve the "best view" (e.g., straighten the ear canal walls, maximize clear aperture);
- ii) to effectively transmit light to the tympanic membrane and to collect light transmitted back from the tympanic membrane in order to effectively permit viewing
25 thereof;
- iii) to provide an effective substantially fluid-tight seal with the ear as well as with the instrument head in order to permit insufflation (e.g., pneumatic otoscopy);
- iv) to allow placement and use of certain instrumentation while viewing through the optics, for cerumen (ear wax) removal.
- 30 v) to permit stacking of the tips in a compact fashion to facilitate storage in a dispenser or work kit;
- vi) to be adequately cost-effective terms of manufacture in order to permit the tips to be disposable or replaceable;

- vii) to prevent cross-contamination;
- viii) to fit a variety of patients (e.g., different sizes)
- ix) to minimize the risk of unsafe insertion into the typical ear; and,
- x) to fit relevant otoscopes used.

5 To meet this fairly comprehensive list of requirements, it becomes clear that any presently known otoscope tip would either optimize for only one or two of the above attributes, or perform moderately on a few of them. As a result, there are shortcomings, particularly with regard to disposable speculum tip designs that are presently available.

10 It is an object of the present invention to overcome or ameliorate at least one of the disadvantages of the prior art, or to provide a useful alternative.

Summary of the Invention

According to a first aspect of the present invention there is provided a tip element for securing to an otoscope, said tip element comprising:

15 a substantially axisymmetric body having a distal open end and an open proximal end; and

at least one external engagement feature extending radially from an outermost circumferential surface at said open proximal end of said tip element, each said at least one external engagement feature being adapted for engaging a tip attachment mechanism of an otoscope and provided with an engagement surface that ramps axially around a
20 portion of the circumference of said open proximal end, said at least one external engagement feature further including a finger-gripping rib.

25 Unless the context clearly requires otherwise, throughout the description and the claims, the words "comprise", "comprising", and the like are to be construed in an inclusive sense as opposed to an exclusive or exhaustive sense; that is to say, in the sense of "including, but not limited to".

The at least one external engagement feature of the herein described tip element preferably is defined by a circumferential securing portion that is sized to fit within a securing slot of a tip attachment mechanism of an otoscope when the tip element is twisted thereupon in a first predetermined direction.

30 Preferably, the at least one external engagement feature further includes at least one axial portion depending from the circumferential securing portion, the at least one axial portion extending axially in a direction toward the distal open end of the tip element. In a preferred version, three (3) external engagement features, as described

above, are provided, though this number can be suitably varied. A plurality of axial gripping ribs can also be provided on the exterior of the tip element, some or all of these ribs including the axial portions of the external engagement features.

According to another preferred aspect of the invention, angled tabs, ribs or
5 wedges are disposed about the periphery of the proximal end of the tip. Preferably, at least one of the engagement features of the tip element and the otoscope include sawtooth like "steps" in order to provide tactile feedback for the user when attached to the instrument head and to improve the engagement and sealed connection therebetween.

The otoscopic tip element can further include at least one interior engagement
10 feature as well, for permitting attachment of the otoscopic tip element to an attachment portion of another type of otoscope, thereby permitting the tip element to be used more or less universally or interchangeably with various types of tip attachment mechanisms as provided on different otoscopes. Preferably, the interior surface of the tip element is preferably polished in order to improve light transmissibility and further includes an
15 interior sealing feature, such as an annular sealing ring, that permits or aids in the sealing of the tip element relative to the otoscope for insufflation purposes.

According to a second aspect of the present invention there is provided a tip element for use with an otoscope, said tip element including

a substantially axisymmetric body including an open distal end and an open
20 proximal end; and

adaptive engaging means provided on said substantially axisymmetric body for interchangeable attachment with at least two different otoscope tip attachment mechanisms, wherein said adaptive engaging means includes a first engaging means that includes at least two external engagement features extending radially from said open
25 proximal end and circumferentially equispaced about a portion thereof and said second engaging means that includes at least one internal engagement feature.

Preferably, the at least one external engagement feature is provided radially relative to the body of the tip element and includes at least one circumferential securing portion sized for engaging a securing slot formed on an attachment portion of the
30 instrument head. Preferably, the at least one interior engagement feature includes at least one protrusion sized for engaging a bayonet-like slot in an attachment portion of an instrument head.

Preferably, the securing slots and the circumferential securing portions are substantially wedge-shaped, wherein the tip element is twisted in a first predetermined direction in order to engage the at least one circumferential securing portion with the at least one securing slot of the instrument head. According to a preferred version, a set of
5 teeth are provided on an engagement surface of at least one of the securing slot and circumferential securing portion.

A plurality of tip elements can be provided in which the tip elements can be color-coded based on the type of patient used (size of the tip) and/or intended use thereof.

10 The tip elements as described are preferably disposable and to that end are fabricated such that their geometry permits stacking. At least one axial portion, depending from the at least one circumferential securing portion, assists in the stackability of a plurality of tip elements as well as provides a gripping surface to aid in attaching and removing the tip from the otoscope. In addition and according to a
15 preferred version, a plurality of axial ribs additionally provided on the exterior of the tip element further provide means for gripping, as needed.

According to a third aspect of the present invention there is provided an otoscopic assembly including at least one otoscopic instrument having an instrument head that includes at least one tip attachment mechanism and a releasably attachable tip element,
20 said tip element comprising:

a substantially axisymmetric body having an open distal end and an open proximal end; and

means for adaptively engaging said tip element with said instrument head, wherein said adaptive engaging means permits interchangeable attachment of said tip element to
25 at least two different tip attachment mechanisms, said adaptive engaging means including first engaging means for engaging a first otoscopic tip attachment mechanism and a second engaging means for engaging a second otoscopic tip attachment mechanism, said first engaging means including at least two circumferentially
30 equispaced external engagement features extending radially from said open proximal end, each of said external engagement features being provided with an engagement surface that ramps axially around the circumference of said open proximal end.

Preferably, the otoscopic instrument includes an optical system contained therein that when aligned with an attached tip element permits the entire tympanic membrane to be viewed without panning of the instrument.

5 Preferably, an instrumentation tip element can be attached to the otoscopic instrument in lieu of the tip element previously described, the instrumentation tip element having an open-framed structure that defines openings that permit the insertion of at least one surgical instrument, such as a curved curette. The structure of the instrumentation tip permits instrument insertion without significantly interfering with the viewing of a target by the user.

10 Alternatively, an elastomeric seal assembly is further provided according to another embodiment which permits a substantially fluid-tight seal to be formed when the assembly is attached onto the exterior of a tip element. In addition, the assembly is shaped to permit the assembly to be selectively moved along the length of the tip element to optimize the seal.

15 Preferably, the tip attachment mechanism preferably includes at least one circumferentially disposed securing slot on a distal facing surface of the instrument head that is sized for receiving a corresponding securing portion of a tip element. Preferably, the rotatable actuable means includes an actuator knob that includes at least one pin element for displacing the tip element from the securing slots upon rotation of the knob in a predetermined direction. The rotatable actuable means is preferably biased so as to return the pin element to a home position, the means further including at least one indicator to indicate the predetermined direction to the user.

20 According to a fourth aspect of the present invention there is provided a method for manufacturing a substantially axisymmetric speculum tip element for an otoscopic apparatus, said method including the steps of:

- 25 providing a tip element with a substantially axisymmetric body having a distal open end and an open proximal end;
- providing at least one external engagement feature permitting said tip element to be releasably attached to an otoscopic instrument via a first tip attachment mechanism,
- 30 each said at least one external engagement feature extending radially from an open proximal end of said tip element and provided with an engagement surface that ramps axially around a portion of the circumference of said open proximal end, said at least one external engagement feature further including a finger-gripping rib;

and manufacturing said tip element by means of a molding process.

According to a sixth aspect of the present invention there is provided an otoscopic assembly including at least one otoscopic instrument having an instrument head that includes at least one tip attachment mechanism and a releasably attachable tip
5 element, said tip element comprising:

a substantially axisymmetric body having a distal open circular end and an open proximal end; and

at least one external engagement feature extending radially from an outermost circumferential surface at said open proximal end of said tip element, each said at least
10 one external engagement feature adapted for engaging said at least one tip attachment mechanism and provided with an engagement surface that ramps axially around a portion of the circumference of said open proximal end, said at least one external engagement feature further including a finger-gripping rib.

One advantage of the present invention at least in a preferred form is that a
15 practitioner can use the herein described instrument without additional training being required.

An additional advantage of the present invention at least in a preferred form is that the improved tip design permits fewer tip sizes to be used while permitting enhanced otological examinations to be conducted.

20 In addition advantageously, at least in a preferred form by permitting use of a universal tip with both multiple existing otoscopes as well as the herein described otoscopic instrument design allows the practitioner having both prior art otoscopes as well as with the herein described otoscope to not have to keep track of the tips being used and permits the doctor or other practitioner to retain both types of otoscopes.

25 The addition of external bayonet-like engagement features on the tip elements creates a "grip" area that advantageously enables users to place the tips onto the existing otoscope more securely than is otherwise presently achievable. In addition, the improved draft angle and polished interior advantageously improves the efficiency of light transmission both into and out from the tip element.

30 Yet another advantage of the present invention at least in a preferred form is the non-contact releasability of the tip element from the otoscope.

These and other objects, features and advantages will become readily apparent from the following Detailed Description which should be read in conjunction with the accompanying drawings.

Brief Description of the Drawings

- 5 FIG. 1 is a side view of an otoscope made in accordance with the present invention;
- FIG. 2 is an isometric view of a disposable otoscopic tip element used in conjunction with the otoscope of Fig. 1;
- FIG. 3 is a front view of the otoscopic tip element of Fig. 2;
- 10 FIG. 4 is a side view of the otoscopic tip element of Figs. 2 and 3;
- FIG. 5 is a rear view of the otoscopic tip element of Figs. 2-5;
- FIG. 6 is a side view, in section, of the instrument head of the otoscope of Fig. 1 as taken through lines 6-6 of Fig. 7;
- FIG. 7 is a top plan view, in section, of the instrument head of Fig. 6;
- 15 FIG. 8 is a front perspective view of the instrument head of Figs. 6 and 7;
- FIG. 9 is a rear perspective view of the instrument head of Figs. 6-8;
- FIG. 10 is a partial front perspective view of the tip release actuator assembly of the otoscope;
- FIG. 11 is an exploded view of the tip release actuator assembly of Fig. 10;
- 20 FIG. 12 is a partially exploded view of a focusing sleeve for use in the otoscope of Figs. 1 and 6-9;
- FIG. 13 is an exploded view of the eyepiece mechanism of the otoscope of Figs. 1 and 6-9;
- FIG. 14 is a sectioned view of the eyepiece mechanism of Fig. 13;
- 25 FIG. 15 is a side elevational view, partially in section, showing various design modifications to the otoscopic tip element as compared to certain known tip element designs;
- FIG. 16 is a side view of an instrumentation tip element made in accordance with one aspect of the present invention;
- 30 FIG. 17 depicts an elastomeric assembly which is attachable to the tip element of Figs. 3-5; and
- FIGS. 18(a) and 18(b) illustrate partial front perspective views of an otoscope tip ejection mechanism shown in two operative positions;

FIG. 19 is a ray trace diagram of the optical system of the otoscopic instrument in accordance with a preferred embodiment; and

FIG. 20 is a side elevational view of the instrument head as attached to an electronic imager used as a viewing means in lieu of an eyepiece mechanism.

5 **Detailed Description**

The following description relates to a preferred embodiment of an otoscope that is made in accordance with the present invention as well as to preferred embodiments of a disposable, releasably attachable otoscopic tip element design. However, from the description there are many variations and modifications that will become apparent to one
10 of sufficient skill in the field that can be made in accordance with the following inventive aspects.

In addition, several terms such as "distal", "proximal", "top", "bottom", "front", "rear", "clockwise", "counterclockwise", and others are used throughout the discussion in order to provide a convenient frame of reference with regard to the accompanying
15 drawings. These terms, however, should not be necessarily be regarded as limiting, except where so specifically indicated.

Referring to Fig. 1, the otoscope herein labeled 10 includes a cylindrical handle portion 14 that contains a set of batteries (not shown) that are retained within an interior battery compartment (not shown), the handle portion having a bottom portion 17 that is
20 preferably removable in order to permit the exchange of batteries. The handle portion 14 permits the instrument 10 to be hand-held and includes a top portion that is sized to accommodate an instrument head 18 which is fitted thereto. The instrument head 18 is substantially hollow so as to accommodate an insufflation port 28, the head being defined by a proximal end 22 and an opposing distal end 26 having an axisymmetric
25 distal insertion portion 29, Fig. 6. The handle portion 14 further includes an actuatable button 23, disposed above the bottom portion 17, that is used to power up the instrument as well as a rheostat 25 that is used to selectively adjust the illumination output of an illumination assembly that is contained in a necked or throat portion of the instrument head 18. It should be noted that each of the above features relating to the handle portion
30 14 are commonly known in the field and require no further explanation with regard to the present invention.

Before referring more specifically to a more detailed description of the remainder of the herein described otoscopic instrument 10, the following discussion refers to Figs.

2-5 and more specifically to a preferred disposable speculum tip element 40 that is releasably mounted in overlaying relation onto the distal axisymmetric insertion portion 29 of the instrument 10. The tip element 40 is made preferably from a moldable plastic material, such as polypropylene, and is defined by a substantially axisymmetric configuration including a pair of open ends, namely a narrowed distal end 44 that tapers outwardly to a wider proximal end 48. The proximal end 22 also contains a number of non-axisymmetric features, discussed in greater detail below.

For purposes of the following discussion, the tip element 40 shown in Figs. 2-5 represents an "adult-sized" tip; that is, a tip element that is used for insertion into the ear of adult patients, though each tip element, regardless of the intended patient, commonly includes a number of engagement features, both external and internal, that permit the tip element 40 to be attached to the otoscope and more particularly to the distal axisymmetric insertion portion 29, Fig. 6. It will be readily understood that the tips can be made with varying sizes, depending on the patient.

In addition to the above, the present tip elements 40 each include a larger distal aperture and can comfortably extend a greater distance into the ear canal of a patient than any previously known disposable tip element of its aperture size.

Referring to Fig. 15, it has been determined empirically that a typical tip element has critical dimensions based on the anatomy of the ear canal and on the conical construction of the distal axisymmetric insertion portion 29 of the instrument 10. Increasing both the inner diameter of the distal end of the tip element 40 and the length of that portion of the tip element insertable into the ear permit a better access to and view of the tympanic membrane. To further illustrate this, a comparison between adult-sized tip elements 40 and pediatric (child) tip elements 40A made in accordance with present invention is provided with previously known tip elements 40', 40A' of the same types as herein represented in Fig. 15. Primarily, each tip element 40, 40', 40A, 40A' includes a pair of surfaces; a first surface represented from the proximal end of each tip element to an intermediate interface, indicated as -I-, needed to accommodate the cone of the distal axisymmetric insertion portion 29 of the otoscope; and a second conical surface that extends from the intermediate interface -I- to the distal tip opening. The present tip elements 40, 40A are each substantially lengthened beyond the intermediate interface -I-, therefore permitting the tip element to be extended a greater distance into the ear canal of the patient. In addition, the distal tip aperture of each tip element 40,

40A is widened as compared with the depicted previous tip designs 40', 40A'. Each of the representative differences are represented tabularly in Fig. 15 along with an overlay of each of the tip elements 40, 40A, 40', 40A', as represented on each of an existing otoscope cone and an insertion portion that is made in accordance with the present
5 invention.

Referring back to Figs. 2-5, each tip element 40, regardless of the intended patient (e.g., pediatric, adult, etc.), includes a plurality of external engagement features 52 that are located in relation to the proximal open end 48 of the tip element. According to this specific embodiment, three (3) such features 52, equally spaced from one another
10 circumferentially by about 120 degrees, are provided, though the actual number of engagement features provided can easily be varied. Each of the external engagement features 52 according to this embodiment extends radially from the open proximal end 48 of the tip element 40 and commonly includes a circumferential securing portion 55 and a depending axial portion 54 forming a substantially L-shape, the circumferential
15 securing portion 55 having a plurality of teeth 56 that are located on an engagement surface thereof. Additionally, the circumferential securing portion 55 is substantially wedge-shaped, the portion having a maximum thickness at the interface with the depending axial portion 54 and a tapered minimum thickness at an opposing end, thereby forming the ramped engagement surface. The depending axial portions 54
20 facilitate stacking of a plurality of tip elements 40, as well as provide a grip surface when attaching the tip elements to the otoscope. An additional plurality of spaced axial ribs 66 disposed between each of the depending axial portions, also provide a gripping surface when attaching the tip elements 40, as is described in greater detail in a later section.

25 The interior surface 60 of the herein described tip element 40 is polished to improve light transmissibility and further preferably includes an angled interior protrusion 64 that is located near the proximal tip opening 44. Referring to Fig. 5, the tip element 40 also includes an interior annular sealing ring 70, which is provided to assist in sealing the tip element to a conical portion of the distal axisymmetric insertion
30 portion 29 of the instrument head 18, preferably for insufflating purposes.

Referring now to Figs. 6 and 7, the instrument head 18 retains a number of components, including the above-described disposable tip element 40 that is mounted in overlaying relation onto the distal axisymmetric insertion portion 29 and to an actuator

mechanism, also described in greater detail in a later portion of this description that permits releasable attachment/disengagement of the tip element 40 to and from the instrument 10.

The above instrument 10 can be used for pneumatic otoscopy as is known
5 through a hose connection 272, Fig. 7, partially shown, to the insufflation port 28, Fig. 7, the hose connection extending to a pneumatic supply (not shown) as is commonly known.

Within the confines of the instrument head 18, and beginning at the distal axisymmetric insertion portion 29 and extending proximally therefrom along a defined
10 optical axis 27 is an imaging train that includes a predetermined number of optical elements, most of which are disposed within an open-ended tubular member 80. The tubular member 80 has a variable diameter that is defined herein by three axial sections, each axial section having a different interior diameter. The first axial section 84 of the tubular member 80 is defined by an initial diameter at the distal end thereof, and is sized
15 for retaining an objective distal or front lens 96 and a lens 100, respectively, each of these lenses being disposed in adjacent relation to one another to form a doublet. The lenses 96 and 100 are mounted adjacently to one another, with the objective distal lens 96 partially extending outwardly from the distal most opening of the tubular member 80. The second axial section 88 of the tubular member 80 is defined, according to this
20 embodiment, by a second interior diameter that is larger than the diameter of the first axial section 84, the second section linking an adjacent third section 92 that contains a first relay lens 104, an aperture stop 108, and a second relay lens 112, respectively, each of these elements being appropriately spaced from one another. The diameter of the third axial section 92 of the tubular member 80 is larger than either of the diameters of
25 the first and second portions 84, 88 thereof. A functional discussion of the imaging train as well as that of the overall optical system of the herein described embodiment 10 is provided in a later portion herein.

Referring back to the overall assembly of the instrument 10, the tubular member 80 is retained within an inner former assembly 116 that is also positioned within the
30 instrument head 18, wherein the first axial portion 84 of the tubular member 80 is sized to fit within the distal axisymmetric insertion portion 29. The inner former assembly 116 provides support for the tubular member 80 and further provides means for a plurality of extending optical fibers (not shown) from an illumination assembly 124.

Referring to Fig. 6, the illumination assembly 124 is fitted within a necked or throat portion of the instrument head 18, the illumination assembly comprising a miniature incandescent lamp 128, the lamp being mounted within a base 136 and connected thereto via a lamp retainer 140, each of the above being held within a cylindrical sleeve member 5 144. A bumper guard 146 is placed onto the top of the lamp 128 in order to protect the lens envelope. The electrical connections of the illumination assembly with the batteries (not shown) provided in the handle portion 14, Fig. 1, as well as the interconnection to the rheostat 25, Fig. 1, are commonly known and do not form an essential part of this invention.

10 Preferably, the first axial portion 84 of the tubular member 80 is fitted within the interior of the distal axisymmetric insertion portion 29 such that the distal objective lens 96 is proximate the distal opening thereof, as shown in Fig. 6, the tubular member and surrounding inner former assembly 116 being placed through an opening in the instrument head interior that is sized for accommodating same. Preferably, the tubular 15 member 80 is sealed to the proximal end of the inner former assembly 116 using a suitable adhesive, wherein a portion of the third axial section 92 of the tubular member extends therefrom. The seal, shown as 150 in Fig. 7, must be proximal (e.g., behind) the insufflation port 28 in order to permit insufflation to be achieved, such as through a hose connection 272, partially shown in Fig. 7, to a pneumatic supply. In other words, air 20 entering the insufflation port 28 would flow forward (e.g., toward the insertion portion and the distal tip) meaning that the seal must be toward the proximal end beyond the insufflation port.

An eyepiece mechanism 160, as more specifically shown in Figs. 6, 7, 13 and 14, is retained at the proximal end 48 of the instrument head 18, the mechanism including a 25 substantially cylindrical lens carrier member 164 having a set of external threads 168 that are disposed adjacent to a square distal end 172 thereof. The square distal end 172 of the lens carrier member 164 is sized to be fitted into a corresponding opening 180, Fig. 7, provided within the interior of the instrument head 18 that retains the lens carrier member 164 and prevents the member from rotational movement. A tubular lens 30 retainer member 176 is fixedly attached to the lens carrier member 164 by means of corresponding threaded portions 186, 184 on the interior distal end of the lens retainer member 176 and the exterior of the proximal end of the lens carrier member 164, respectively. The lens retainer member 176 includes an interior that is sized for

receiving a pair of optical lenses 190, 194, that, when the lens retainer member and the lens carrier member are assembled to the instrument head 18, are aligned along the optical axis 27, Fig. 7, on which the optical elements 96, 100, 104, 112 of the imaging train are also aligned.

5 The eyepiece mechanism 160 further includes a wave spring 192 and a lens retainer 196, each being disposed between the lens 190 and the lens carrier member 164. In addition, a spacer 195 is disposed between the lenses 194, 190 and an O-ring 199 is used to seal the lens 194 with the lens carrier member 176.

Referring to Figs. 6, 7 and 12, the external threads 168 of the lens carrier member
10 164 engage with a set of corresponding threads 207 that are provided on the interior surface of a cylindrical focusing sleeve member 200 that is fitted thereupon in overlaying relation. The focusing sleeve member 200 has an axial length extending so as to project from the proximal end 48 of the instrument head 18 when the sleeve member is attached. A soft grippable elastomeric cover 202 overlays an axial portion of
15 the sleeve member 200, the cover being mounted to rotate along with the sleeve member to an end of travel as determined by protrusion 203. A ball and compression spring 204, 206, shown only in Fig. 7, are each disposed within the interior of the instrument head 18, each being aligned with a single depression (not shown) that is formed on the exterior of the focusing sleeve member 200, the spring biasing the ball and forming a
20 rotational detent that signals to the user that a predetermined factory-set focus position has been reached. A focusing knob 208 is snap fitted onto the extending proximal end of the focusing sleeve member 200. The focusing knob 208 includes a center opening 212, permitting the user/practitioner to view a target along the aligned optical axis 27, as does each of the focusing sleeve member 200 and the lens retainer member 176,
25 respectively, and permitting selective axial adjustment of the eyepiece mechanism 160, Fig. 13, relative to the imaging train through rotational movement of the sleeve member 200. Preferably and during assembly, the lens retainer member 176 is adjusted relative to the lens carrier member 164. This adjustment permits creating a factory setting, for example, for humans at a certain focal length, and a different factory setting for
30 example, for veterinary uses having a longer default focus position, wherein the sleeve member simply adjusts either above or below this position.

For purposes of adjustability, the instrument head 18 further includes a pair of windows 21, Figs. 8, 9, that are formed on opposing lateral sides thereof, wherein axial

portions of the soft grippable elastomeric cover 202 to the sleeve member 200 are accessible to a user in addition to the focusing knob 208, as shown, for example, in Figs. 8 and 9.

The tip actuator mechanism of the instrument 10 is now explained in greater
5 detail with reference to Figs. 2-5, 10, 11, and 18(a) and 18(b). This mechanism includes a tip element retainer member 240 that is stationarily attached to the distal end of the instrument head 18, the retainer including a plurality of circumferentially spaced slots 242. In this embodiment, three slots 242 are provided, in which two of the slots include circumferential ramped surfaces 244. Each of the ramped surfaces 244 includes a set of
10 teeth for engaging with the teeth 56 that are provided on the external engagement tabs 52 of the tip element 40. The tip actuator mechanism further includes a rotatable actuator knob 252 that is biased by means of a spring 256, the spring having an axial first end 260 that passes through a slot 264 in the actuator knob 252 to a hole 268 provided in the retainer member 240. The remaining end 269 of the spring 256 fitted within a slot 270
15 that is formed on the actuator knob 252. The retainer member 240 attaches to a front facing surface of the rotatable actuator knob 252, the actuator knob further including a pin 254 that extends from the front facing surface into that slot 242 in the retainer member not having the circumferential ramping surfaces 244.

In operation, an otoscopic tip element 40 as described above, is attached onto the
20 distal end of the instrument head 18 and more specifically in overlaying relation to the distal axisymmetric insertion portion 29, the circumferential securing portions 55 of each of the external engagement features 52 being fitted into the circumferential slots 242 that are provided in the tip element retainer member 240. The tip element 40 is then twisted, in this example, in a clockwise fashion, so as to engage the teeth 56 of two of the wedge-
25 like engagement features 52 with the corresponding ramped surfaces 244 of the tip element retainer member 240, thereby providing positive engagement and providing tactile feedback to the user when attaching the tip element 40 to the instrument 10.

Referring to Figs. 10, 11 and 18 (a) and (b), and in order to release a tip element 40 from the instrument 10 following a patient examination, the actuator knob 252 is
30 rotated in a counter-clockwise direction as denoted preferably by an indicator 261 located on the exterior of the actuator knob 252. This causes rotational movement of the knob 252 relative to the stationary tip element retainer member 240 and further causes a front face pin 254 to move that slot 242 not having a ramped surface 244, driving the tip

element 40 rotationally from the slots of the retainer member 240, releasing the tip element.

The design of the herein described tip element 40 is fairly universal; that is, the tip element is designed not only to fit the herein described instrument 10, but a number
5 of already existing otoscopes, such as those employing bayonet-type attachment scheme as described by U.S. Patent No. 3,698,387, and ejector-type mechanism as described by U.S. Patent No. 4,366,811 the entire contents of each herein being incorporated by reference.

In operation, the use of the focusing mechanism permits relative movement of
10 the optics of the eyepiece mechanism 160 relative to the imaging train of the instrument 10. The focusing sleeve member 200 and the soft grippable elastomeric cover piece 202 are each permitted to rotate about the optical axis 27, while the lens carrier member 164 and attached lens retainer member 176 are caused only to translate linearly due to the rotationally fixed connection with the instrument head 18. The remainder of the optical
15 imaging train, disposed within the tubular member 80, including front objective lens 96 is stationary, and therefore relative movement is achieved, permitting focus adjustment to take place. As noted, the biased engagement of the ball by the compression spring into the depression of the focusing sleeve member 200 provides an indication of a predetermined fixed focus position (a preset position or distance between the eyepiece
20 optics and the optics of the remainder of the stationary imaging train within tubular member 80) as sensed by the user/practitioner.

Indication of this preset or other focus position can be achieved by means of a visual indicator 209, provided on the exterior of the grippable elastomeric cover 202, portions of the cover being accessible through the windows 21 formed on lateral sides of
25 the instrument head 18 to enable selective rotary movement of the focusing mechanism by mean of the soft grippable cover 202 in lieu of the focusing knob 208.

A scale of markers 213 are formed on edge portions of the instrument head adjacent the windows 21 including a preset focus position marker 215 that can be aligned with the visual indicator 209 which, in combination with the detent, further
30 indicates the preferred nominal focusing position of the instrument 10.

In the predetermined fixed focus position, according to this embodiment, the overall length of the entire imaging system (e.g., the distance between the most distal and proximal optical surfaces including the eyepiece optics) is approximately 77.60 mm,

the magnification is 1.63 X when the tympanic membrane is located at a working distance of approximately 10 mm from the open distal end 44 of the speculum tip element 40, and the depth of field is approximately 3-5 mm. Additionally, the nominal eye relief is approximately 21.5 mm.

5 Referring to Figs. 7 and 19, the aperture stop 108 is optically conjugate to both the entrance pupil 8 and the exit pupil 9 of the entire optical system. The axial location and the size of the entrance pupil 8 are critical in achieving an unobstructed view of the entire tympanic membrane, shown schematically in Fig. 19 as 6. If the entrance pupil 8, which is located distally relative to lens 96, is too close to that lens, there is excessive
10 obstruction of rays emerging from the upper edge of the tympanic membrane 6 by the end of the tip element 40. If the entrance pupil is located too far distally from lens 96, then there is excessive obstruction of rays emerging from the upper edge of the tympanic membrane 6 by the edge of the first or last optical surface of the doublet consisting of lens 96 and lens 100. In this embodiment, the entrance pupil 8 is located in close
15 proximity to the objective lens doublet (lenses 96 and 100), such as to achieve the optimal view of the tympanic membrane 6 with minimal ray obstruction. Similar considerations apply to the physical size of the aperture stop 108.

The exit pupil 9 is located approximately 21.5 mm proximal to the most proximal optical surface of lens 194. This distance provides: a) optimal image stability in relation
20 to lateral movement of the user's eye during an ear examination; b) optimal viewing of the tympanic membrane 6 with minimal ray obstruction; and c) the ability to accommodate a large range of spectacle lenses. This exit pupil location relative to lenses 190 and 194 is constant regardless of the position of the focusing mechanism.

The optical system described herein can easily be expanded to video/imager
25 human otoscopy by adding an electronic imager assembly 304 onto the proximal end of the otoscope, as shown in Fig. 20. In addition, the herein described instrument can similarly be used for optical or video/imager based veterinary otoscopy. Furthermore, one can easily and conveniently modify the optical system shown herein by using appropriate optical adapters, e.g., by adding optics to the viewing means shown in the
30 preceding embodiment.

Selective focusing travel of the lenses 190 and 194 of the eyepiece mechanism is such as to give the user the ability to achieve a close-up view (important in infant ear examinations) and a distant view (important in throat and nasal examinations). The

working distance between the tympanic membrane 6 and the first optical surface of the distal lens 96 is optimized according to this embodiment to fall around 27 mm; this latter dimension is clinically important because it provides the correct setup between inserting the otoscope too deeply into the ear canal. In addition, the herein described optical
5 system produces an erect image of the tympanic membrane to the user at the viewing means.

The imaging train substantially places the objective doublet 96, 100 within the ear at the time of examination, since this optical element is located in the distalmost portion of the instrument head 18, and much closer to the tympanic membrane than any
10 typical otoscope. As a result, a greater (e.g., wider) field of view is achieved, i.e., an area larger than that of the tympanic membrane can be viewed by the user in an operative position of the instrument. Moreover, the entrance pupil location enables an unobstructed view of a typical 7 mm adult tympanic membrane for working distances greater than or about 27 mm, wherein the working distance is defined as the spacing
15 separating the tympanic membrane from the distal surface of the lens 96 or approximately, according to this embodiment, about 9.5 mm from the tympanic membrane to the distal end of the tip element 40. By creating a field of view greater than about 9 mm at a working distance of about 33 mm using the herein described optical system, the entire tympanic membrane can be observed without panning of the
20 instrument 10. The separation between the optics contained within the tubular member 80 and the eyepiece optics 190, 194 is variable in order to permit focusing in a suitable range of working distances and compensating for user's accommodation. As a result of the foregoing, an appropriate tradeoff is achieved between magnification, field of view, working distance, eye relief and focusing range. The latter parameter is additionally
25 critical so as to allow the instrument to be further used, for example, for examinations of the throat and/or nose of the patient.

An additional problem associated with otoscopes, particularly imaging styles with optics located in the main line of sight, is that inserting instruments into the ear is very difficult to do while seeing through the optics. Diagnostic otoscopes and others
30 enable a magnifying window to slide to the side or out of the way, but the resulting view is typically extremely compromised and the use of a curette through the constrained area is far from ideal.

Referring to Fig. 16, an instrumentation tip 280 and a curette 284 are herein described dealing with the above-stated problem, which allows for significantly better instrument insertion while still viewing through the optics of an otoscope 10, such as that previously described, for example. The instrumentation tip 280 according to this embodiment is essentially a cage-like member 290 that extends the tip contacting the patient away from the otoscope, leaving a large open area into which the curette 284 can be inserted and manipulated. It should be understood that the tip that contacts the patient can take a variety of shapes and sizes as can the cage distance and support structure. In this embodiment, the cage-like member 290 is defined by three legs 294 extending between a distal ear insertion portion 298 and a proximal otoscope attachment portion 299, the entirety of the cage-like member being approximately one inch in length. The curette 284 is ideally curved to maximize the ability to manipulate it within the defined open areas between the legs 294. Alternative configurations where some or the entire cage is reusable or integrally attached to the scope should be readily apparent to one of sufficient skill in the field. However, the advantage of a fully disposable version is that the nature of instrumentation implies that some foreign body has been removed from the ear which increases the exposure and risk of cross-contamination. It should be noted that the length of the tip and the otoscope optics must be matched such that the area in front of the tip is in focus to the use of instrumentation. The otoscope attachment portion 299 preferably includes external engagement features, such as shown in Figs. 2-5, and/or including an internal bayonet, depending on the tip attachment mechanism of the otoscope used therewith.

Referring to Fig. 17, a further problem, with disposable otoscope tips is that they do not seal well to the majority of most patient's ears. Further, soft over-mold tip versions seal relatively well, but prevent insertion within the ear beyond the depth at which the elastomer interferes with the ear. Therefore, although the tips achieve an effective seal, they prevent or impede the visualization that is essential during insufflation. It serves no practical purpose to seal and insufflate if the tympanic membrane cannot be viewed during this process, as the movement (or lack thereof) creates the basis for diagnosis.

To deal with the above stated problem, an elastomeric seal accessory 300 is provided according to one embodiment that slides onto the exterior of a disposable tip element, such as those previously described in Figs. 2-5, or other version having a

substantially conical body. This elastomeric seal accessory 300 provides a good seal to the patient's ear and is adjustable in its axial position on the tip 40. Therefore, the tip can be set for "deeper" insertion or shallow insertion so that both the seal as well as the proper insertion depth for visualization can be achieved. This seal accessory 300 is
5 preferably compliant enough that it is set at the distal end of the tip and "pushes in" as the practitioner inserts the tip into the ear canal (not shown).

Additional features, such as markings on the tip and depth setting provide advantages. The geometry of the elastomeric seal accessory 300 itself also creates an advantage since it is mushroom-shaped in the present embodiment, allowing the
10 accessory to collapse in order to seal with a variety of ear canal sizes. An additional advantage exists in the case of the present mushroom-shaped design in that these tips are less sensitive to positional variation (i.e., the accessory can be sealed at many different positions along the tip). Therefore, the axial position of the accessory 300 can easily be varied along the length of the tip in order to effectively optimize the seal. It should be
15 readily apparent that there are alternative geometries that could be conceived for the elastomeric seal accessory, embodying the inventive concepts employed herein.

THE CLAIMS DEFINING THE INVENTION ARE AS FOLLOWS:-

1. A tip element for securing to an otoscope, said tip element comprising:
5 a substantially axisymmetric body having a distal open end and an open proximal end; and
at least one external engagement feature extending radially from an outermost circumferential surface at said open proximal end of said tip element, each said at least one external engagement feature being adapted for engaging a tip attachment mechanism of an otoscope and provided with an engagement surface that ramps axially around a portion of the circumference of said open proximal end, said at least one external engagement feature further including a finger-gripping rib.
10
2. A tip element as recited in claim 1, wherein the engagement surface of said at least one external engagement feature includes a set of teeth.
- 15 3. A tip element as recited in claim 1, wherein said finger-gripping rib is axially disposed.
4. A tip element as recited in claim 1, wherein each said at least one external engagement feature is sized to fit within a securing slot of a tip attachment portion of an otoscope when said tip element is twisted thereupon in a first
20 predetermined direction.
5. A tip element as recited in claim 1, including three external engagement features, each of said external engagement features being provided with said engagement surface.
6. A tip element as recited in claim 5, including three finger-gripping ribs.
- 25 7. A tip element as recited in claim 5, wherein each of said external engagement features are equally spaced from one another about the periphery of said open proximal end.
8. A tip element as recited in claim 1, including an interior surface, said interior surface being polished.

9. A tip element as recited in claim 1, wherein said tip element is disposable.
10. A tip element as recited in claim 1, including at least one internal engagement feature adapted for engaging with a tip attachment mechanism of an otoscope.
11. A tip element as recited in claim 10, wherein said at least one external
5 engagement feature is configured to interface with a first tip attachment mechanism and said at least one internal engagement feature is configured to interface with a second tip attachment mechanism which is different than said first tip attachment mechanism.
12. A tip element as recited in claim 11, wherein said at least one external
10 engagement feature and said at least one internal engagement feature are each configured to engage with respective first and said second tip attachment mechanisms that are provided on separate otoscopes.
13. A tip element as recited in claim 1, wherein said tip element includes a plurality of finger-gripping ribs axially disposed in relation to said open proximal end of
15 said tip element.
14. A tip element as recited in claim 1, including an interior surface, said interior surface including sealing means for sealing said tip element to an otoscope to permit insufflation.
15. A tip element as recited in claim 14, wherein said sealing means includes at least
20 one annular ring disposed within the interior of said tip element.
16. A tip element for use with an otoscope, said tip element including a substantially axisymmetric body including an open distal end and an open proximal end; and
25 adaptive engaging means provided on said substantially axisymmetric body for interchangeable attachment with at least two different otoscope tip attachment mechanisms, wherein said adaptive engaging means includes a first engaging means that includes at least two external engagement features extending radially from said open proximal end and circumferentially equispaced about a portion

thereof and said second engaging means that includes at least one internal engagement feature.

- 5 17. A tip element as recited in claim 16, wherein said at least one internal engagement feature includes at least one protrusion provided on an interior surface of said tip element, said at least one protrusion being sized for engaging a bayonet-like slot formed in an attachment portion of an instrument head.
18. A tip element as recited in claim 16, wherein said at least two external engagement features are sized for engaging corresponding slots formed on an attachment portion of an instrument head.
- 10 19. A tip element as recited in claim 18, wherein each of said at least two external engagement features contains an engagement surface that ramps axially around a portion of said open proximal end and wherein said tip element is twisted in a first predetermined direction to engage said corresponding slots.
- 15 20. A tip element as recited in claim 19, wherein at least one of said external engagement features includes a set of teeth disposed on said engagement surface.
21. A tip element as recited in claim 16, including three circumferentially equispaced external engagement features.
22. A tip element as recited in claim 16, wherein said tip element is disposable.
23. A tip element as recited in claim 16, including a polished interior surface.
- 20 24. A tip element as recited in claim 16, including a plurality of said tip elements, said plurality of elements being color-coded based on the type of patient and intended use thereof.
- 25 25. A tip element as recited in claim 16, including at least one external axially disposed rib to facilitate stacking of a plurality of said tip elements.
26. A tip element as recited in claim 25, wherein said at least one external axially disposed rib is a depending axial portion of said at least one of said at least two external engagement features.

27. A tip element as recited in claim 25, wherein said at least one axially disposed rib extends in a direction toward said open distal end.
28. A tip element as recited in claim 16, wherein said tip element is adapted to be releasably attachable to more than one type of otoscope.
- 5 29. A tip element as recited in claim 16, wherein the open distal end of said axisymmetric body includes an aperture, which is sized such that, when attached to a said otoscope, said aperture permits the entire tympanic membrane to be viewed at once without panning of the instrument.
- 10 30. A tip element as recited in claim 16, including an interior surface, said interior surface including sealing means for permitting said tip to be sealed with said otoscope and permitting insufflation of a patient.
31. A tip element as recited in claim 30, wherein said sealing means includes at least one annular interior ring.
- 15 32. An otoscopic assembly including at least one otoscopic instrument having an instrument head that includes at least one tip attachment mechanism and a releasably attachable tip element, said tip element comprising:
a substantially axisymmetric body having an open distal end and an open proximal end; and
means for adaptively engaging said tip element with said instrument head,
20 wherein said adaptive engaging means permits interchangeable attachment of said tip element to at least two different tip attachment mechanisms, said adaptive engaging means including first engaging means for engaging a first otoscopic tip attachment mechanism and a second engaging means for engaging a second otoscopic tip attachment mechanism, said first engaging means
25 including at least two circumferentially equispaced external engagement features extending radially from said open proximal end, each of said external engagement features being provided with an engagement surface that ramps axially around the circumference of said open proximal end.
- 30 33. An otoscopic assembly as recited in claim 32, wherein said second engaging means includes at least one internal engagement feature

wherein said at least two circumferentially equispaced external engagement features are sized for engaging corresponding securing slots formed in the first tip attachment mechanism;

5 wherein at least one of said corresponding securing slots contains an engagement surface that ramps axially about said instrument head, and in which said tip element is secured in place on said instrument head by rotation of said tip element in a first predetermined direction to engage said at least one of said corresponding securing slots; and

10 wherein said instrument head includes a rotatable actuator knob to selectively displace said external engagement features from said securing slots.

34. An otoscopic assembly as recited in claim 32, including a plurality of tip elements, wherein said each of said plurality of tip elements includes at least one external axially disposed rib to permit stacking thereof;

15 wherein said at least one external axially disposed rib is formed as an axial portion on at least one of said at least two circumferentially equispaced external engagement features; and

wherein said axial portion extends in a direction toward said open distal end of said tip element.

20 35. An otoscopic assembly as recited in claim 32, wherein said otoscopic instrument further includes an optical system disposed therein, said optical system being aligned with said tip element along an optical axis, wherein the entirety of the tympanic membrane of a patient can be viewed by a user through the distal tip opening of said tip element when attached to said otoscopic instrument.

25 36. An otoscopic assembly as recited in claim 32, further including at least one instrumentation tip element which is attachable to an attachment portion of said otoscopic instrument.

37. An otoscopic assembly as recited in claim 32, including an elastomeric assembly which is attachable to the exterior of a said tip element.

38. An otoscopic assembly as recited in claim 37, wherein said elastomeric assembly is shaped to provide a substantially fluid-tight seal when engaged with the ear canal of a patient to permit insufflation using said otoscopic instrument.
39. A method for manufacturing a substantially axisymmetric speculum tip element for an otoscopic apparatus, said method including the steps of:
5 providing a tip element with a substantially axisymmetric body having a distal open end and an open proximal end;
providing at least one external engagement feature permitting said tip element to be releasably attached to an otoscopic instrument via a first tip attachment
10 mechanism, each said at least one external engagement feature extending radially from an open proximal end of said tip element and provided with an engagement surface that ramps axially around a portion of the circumference of said open proximal end, said at least one external engagement feature further including a
finger-gripping rib;
15 and manufacturing said tip element by means of a molding process.
40. A tip element for securing to an otoscope, said tip element substantially as herein described with reference to any one of the embodiments of the invention illustrated in the accompanying drawings and/or examples.
41. A tip element for use with an otoscope, said tip element substantially as herein
20 described with reference to any one of the embodiments of the invention illustrated in the accompanying drawings and/or examples.
42. An otoscopic assembly including at least one otoscopic instrument having an instrument head that includes at least one tip attachment mechanism and a releasably attachable tip element, said tip element substantially as herein
25 described with reference to any one of the embodiments of the invention illustrated in the accompanying drawings and/or examples.
43. A method for manufacturing a substantially axisymmetric speculum tip element for an otoscopic apparatus, said method substantially as herein described with reference to any one of the embodiments of the invention illustrated in the
30 accompanying drawings and/or examples.

1/13

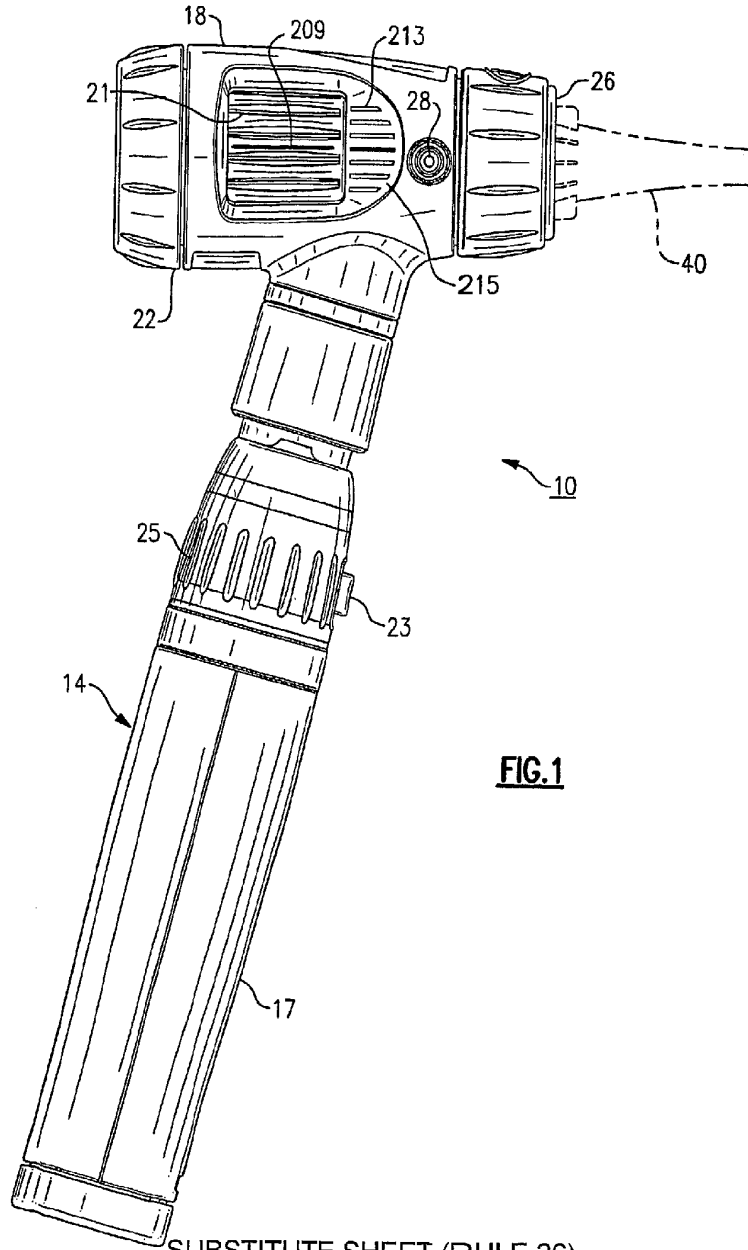

FIG.1

SUBSTITUTE SHEET (RULE 26)

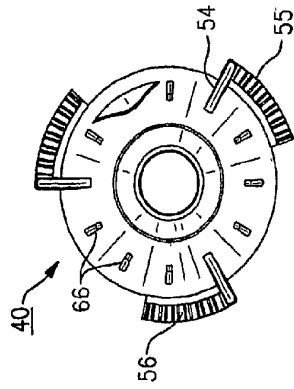

FIG. 3

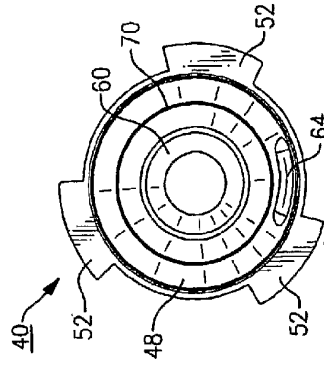

FIG. 5

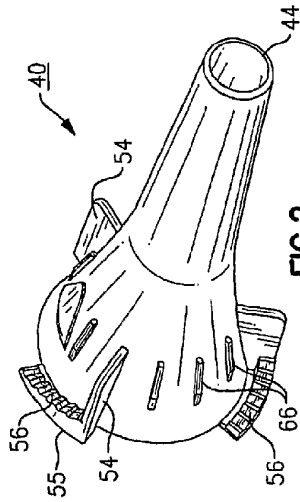

FIG. 2

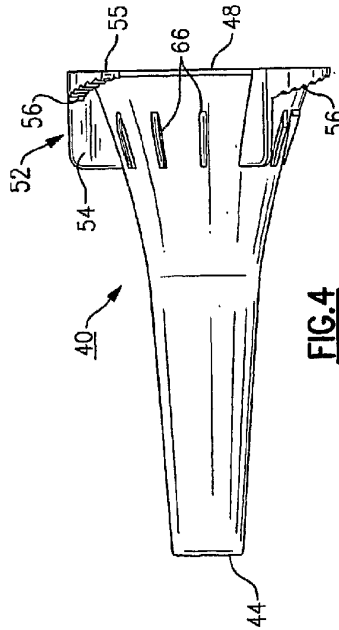

FIG. 4

SUBSTITUTE SHEET (RULE 26)

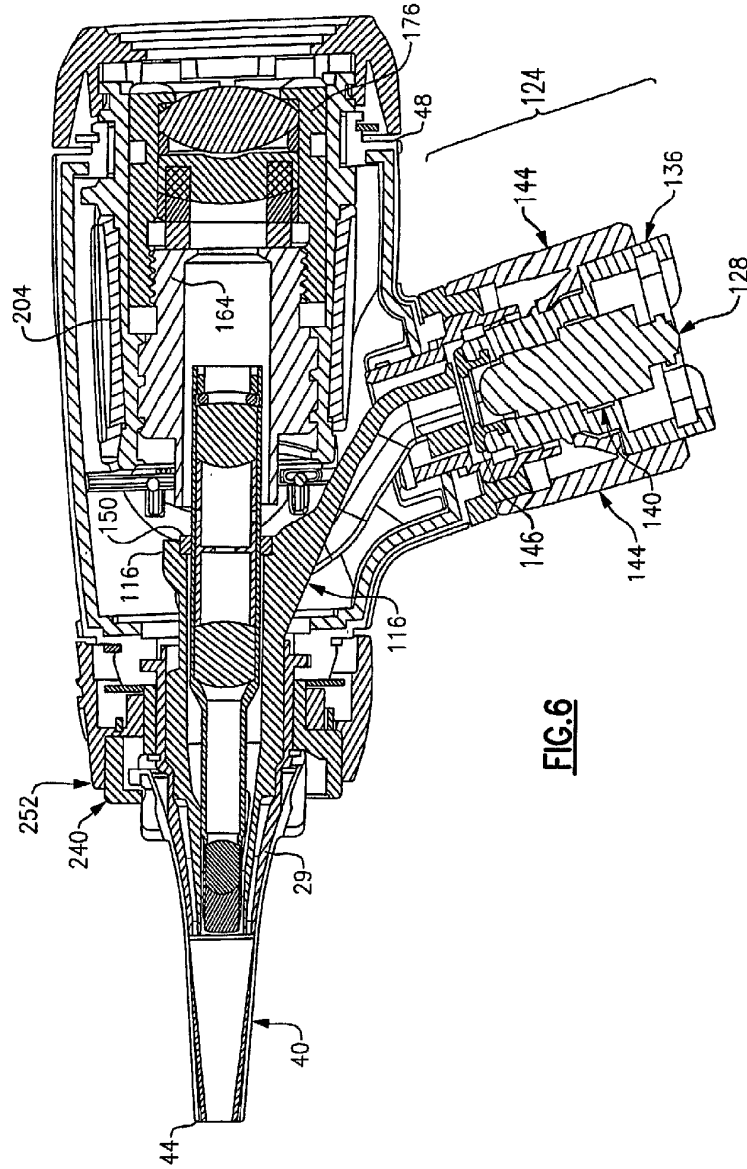

FIG. 6

SUBSTITUTE SHEET (RULE 26)

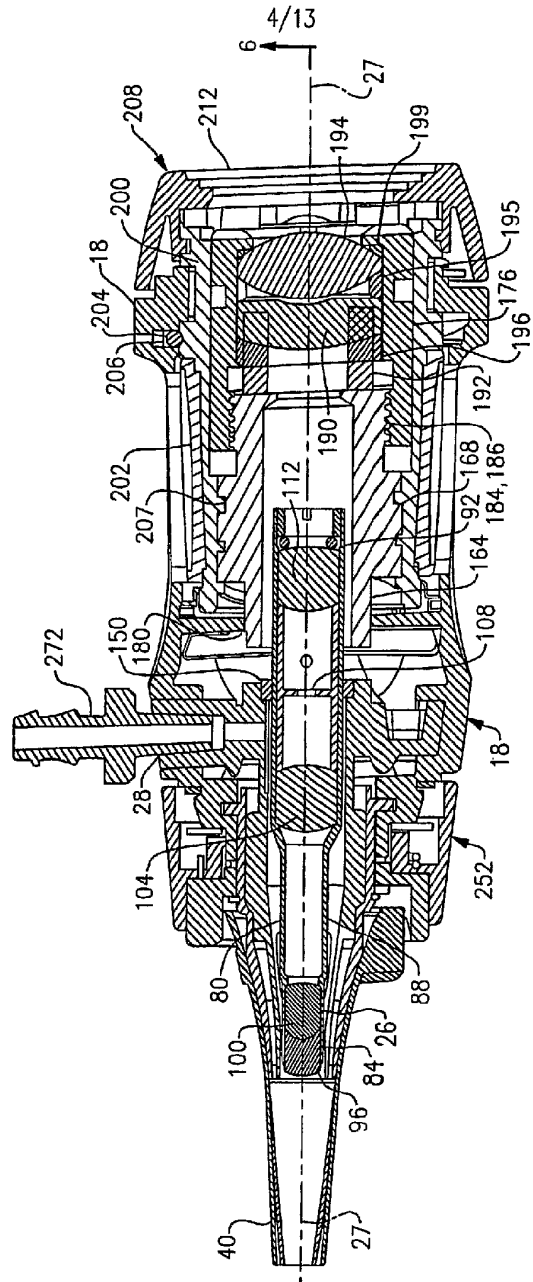

FIG. 7

SUBSTITUTE SHEET (RULE 26)

5/13

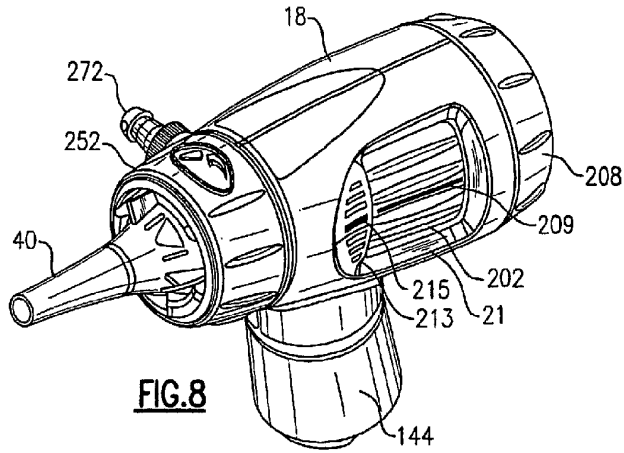

FIG. 8

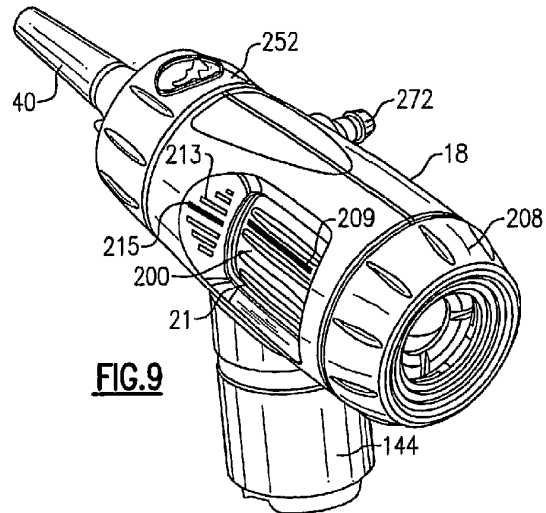

FIG. 9

SUBSTITUTE SHEET (RULE 26)

6/13

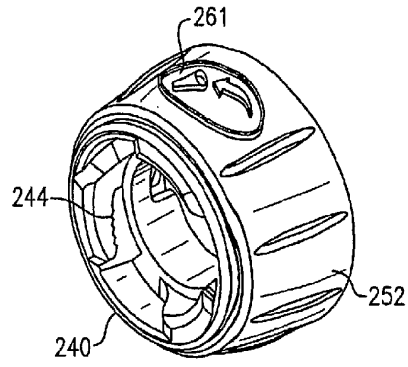

FIG. 10

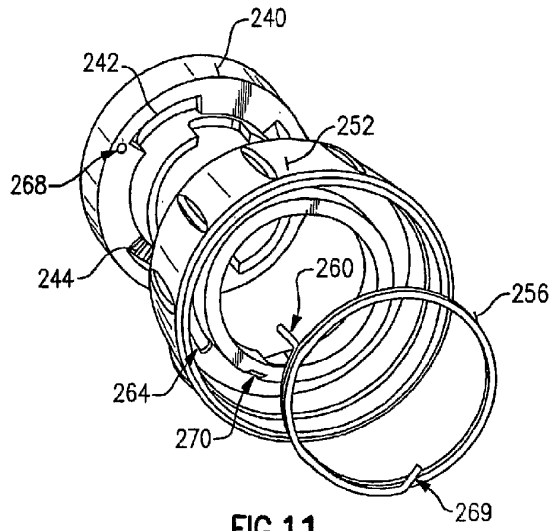

FIG. 11

SUBSTITUTE SHEET (RULE 26)

7/13

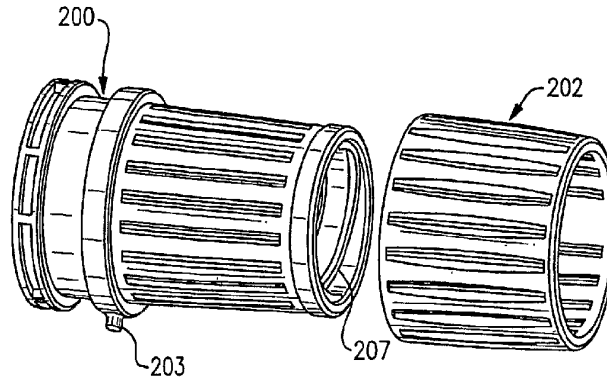

FIG. 12

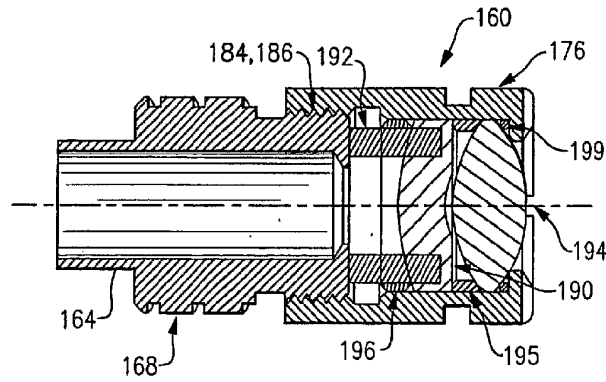

FIG. 14

SUBSTITUTE SHEET (RULE 26)

8/13

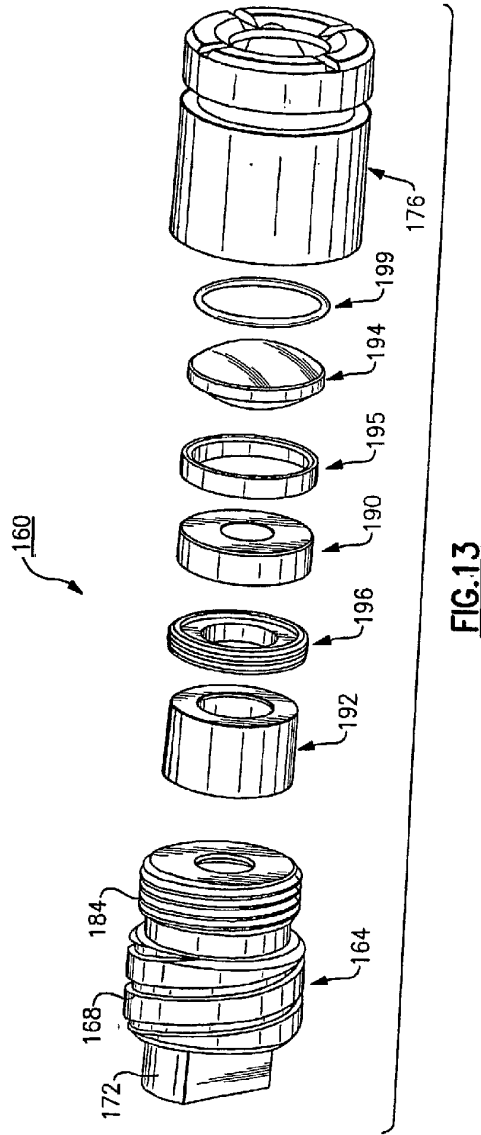
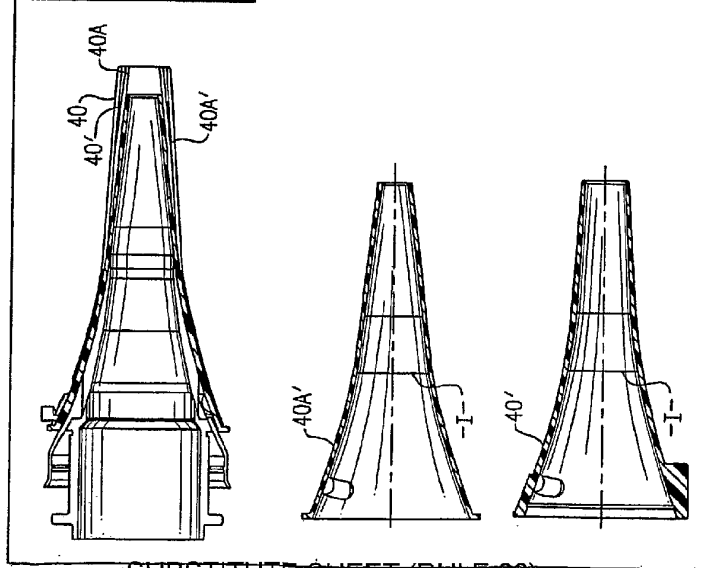

FIG. 13

SUBSTITUTE SHEET (RULE 26)

	LENGTH OF TIP (FROM GAGE POINT I)	EAR CANAL INSERTION LENGTH	APERTURE SIZE	SLOPE	STACKING HEIGHT
40'	.694	.879	Ø .156 (4.0mm)	8"	.200
40	.793	.984	Ø .167 (4.25mm)	8"	.260
40A'	.694	.897	Ø .098 (2.5mm)	14"	.156
40A	.793	.984	Ø 1.08 (2.15mm)	13"	.230



SUBSTITUTE SHEET (RULE 26)

FIG.15

10/13

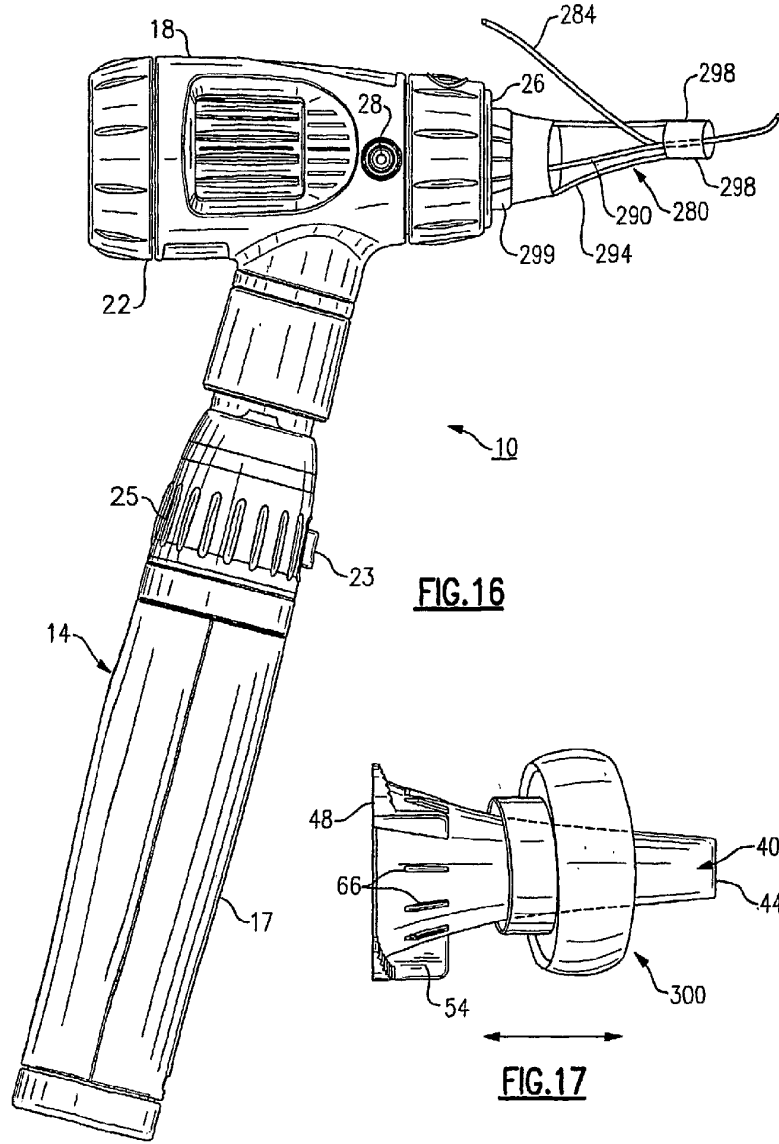

SUBSTITUTE SHEET (RULE 26)

11/13

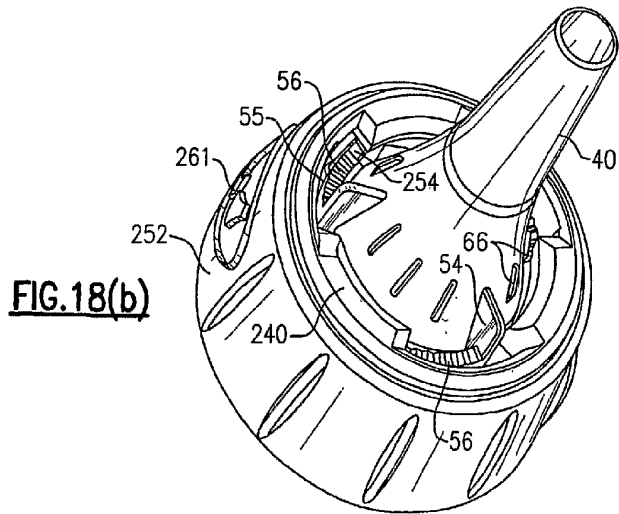
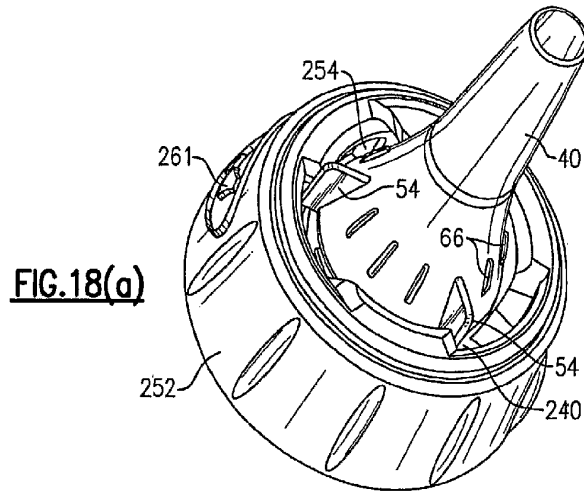

SUBSTITUTE SHEET (RULE 26)

12/13

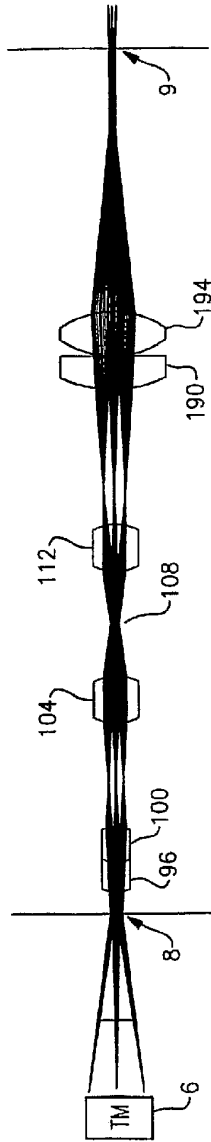

FIG.19

SUBSTITUTE SHEET (RULE 26)

13/13

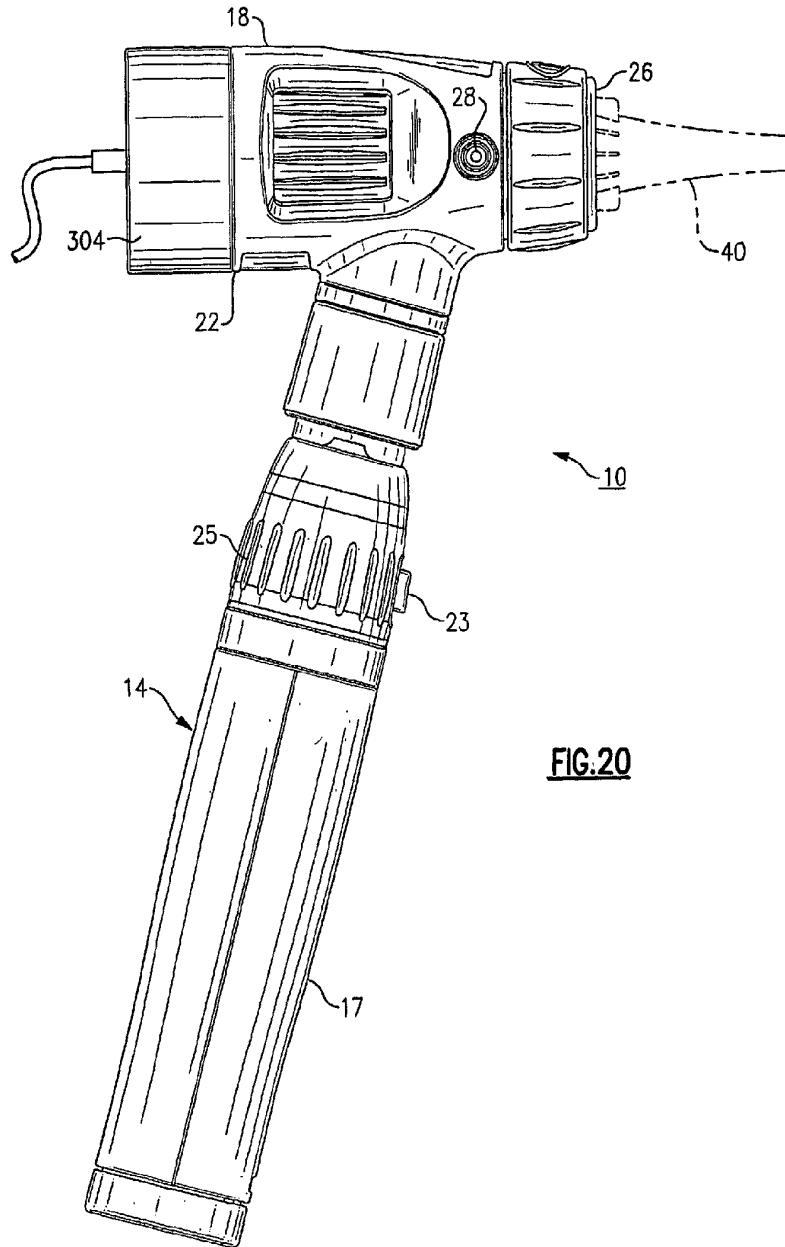

FIG.20

SUBSTITUTE SHEET (RULE 26)