



- (51) **International Patent Classification:**  
*F16B 7/20* (2006.01)
- (21) **International Application Number:**  
PCT/US2014/069095
- (22) **International Filing Date:**  
8 December 2014 (08.12.2014)
- (25) **Filing Language:** English
- (26) **Publication Language:** English
- (30) **Priority Data:**  
14/137,922 20 December 2013 (20.12.2013) US
- (71) **Applicant:** SENKO ADVANCED COMPONENTS, INC. [US/US]; Unit D, 450 Donald Lynch Blvd, Marlborough, Massachusetts 01752 (US).
- (72) **Inventors:** GNADEK, Jeffrey; 419 Kelly Road, Northbridge, Massachusetts 01535 (US). NISHIGUCHI, Yuki; 450 Donald Lynch Blvd, Unit D, Marlborough, Massachusetts 01752 (US). TAKANO, Kazu; 9021 Ambassador Drive, Westborough, Massachusetts 01852 (US).
- (74) **Agents:** MCCARTHY, Alison L. et al.; Pepper Hamilton LLP, Suite 5000, 500 Grant Street, Pittsburgh, Pennsylvania 15219-2507 (US).
- (81) **Designated States** (*unless otherwise indicated, for every kind of national protection available*): AE, AG, AL, AM,

AO, AT, AU, AZ, BA, BB, BG, BH, BN, BR, BW, BY, BZ, CA, CH, CL, CN, CO, CR, CU, CZ, DE, DK, DM, DO, DZ, EC, EE, EG, ES, FI, GB, GD, GE, GH, GM, GT, HN, HR, HU, ID, IL, IN, IR, IS, JP, KE, KG, KN, KP, KR, KZ, LA, LC, LK, LR, LS, LU, LY, MA, MD, ME, MG, MK, MN, MW, MX, MY, MZ, NA, NG, NI, NO, NZ, OM, PA, PE, PG, PH, PL, PT, QA, RO, RS, RU, RW, SA, SC, SD, SE, SG, SK, SL, SM, ST, SV, SY, TH, TJ, TM, TN, TR, TT, TZ, UA, UG, US, UZ, VC, VN, ZA, ZM, ZW.

- (84) **Designated States** (*unless otherwise indicated, for every kind of regional protection available*): ARIPO (BW, GH, GM, KE, LR, LS, MW, MZ, NA, RW, SD, SL, ST, SZ, TZ, UG, ZM, ZW), Eurasian (AM, AZ, BY, KG, KZ, RU, TJ, TM), European (AL, AT, BE, BG, CH, CY, CZ, DE, DK, EE, ES, FI, FR, GB, GR, HR, HU, IE, IS, IT, LT, LU, LV, MC, MK, MT, NL, NO, PL, PT, RO, RS, SE, SI, SK, SM, TR), OAPI (BF, BJ, CF, CG, CI, CM, GA, GN, GQ, GW, KM, ML, MR, NE, SN, TD, TG).

**Published:**

- *with international search report (Art. 21(3))*
- *before the expiration of the time limit for amending the claims and to be republished in the event of receipt of amendments (Rule 48.2(h))*

(54) **Title:** LOCKABLE CONNECTORS AND CONNECTION ASSEMBLIES

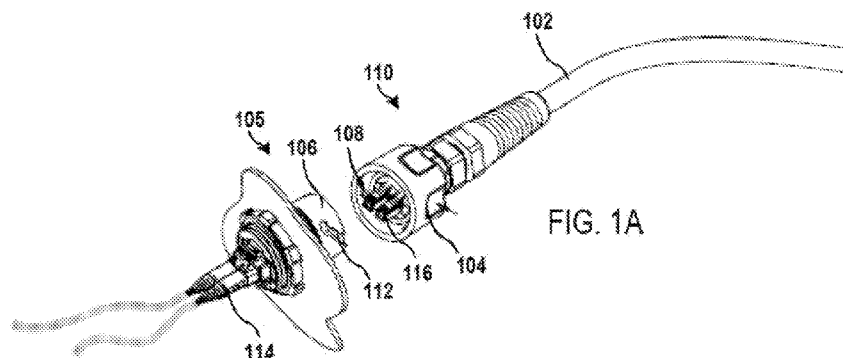

(57) **Abstract:** Lockable connection assemblies including lockable connection components are described. A lockable connection assembly may include an assembly for connecting components in an electrical or communication system, such as a fiber optic communication network. The lockable connection assemblies may include a connector (for example, a plug) and an adapter configured to be connected together, for example, using a bayonet-type connection. The components of the lockable connection assemblies may include elements configured to prevent the connector from unintentionally disconnecting from the adapter. For instance, the connector may include a locking nut configured to engage and lock a coupling nut connected to the adapter from rotating and disconnecting from the adapter. In another instance, the connector may include a coupling nut having finger flanges arranged at one end thereof and configured to engage a non-rotatable connector body when connected to the adapter to prevent the unintentional movement of the coupling nut.



## LOCKABLE CONNECTORS AND CONNECTION ASSEMBLIES

### FIELD OF THE INVENTION

[0001] The described technology generally relates to lockable connection assemblies configured to provide a secure connection between cable segments, equipment, and/or devices, and, more specifically, to complementary connectors and adapters configured to engage in a locking arrangement that prevents the unintended removal of a connector from an adapter.

### BACKGROUND

[0002] The efficiency and reliability of telecommunication networks is dependent on various factors, such as the quality of connections between cable segments, network equipment, devices, and other cable segments. Telecommunication equipment is increasingly being used in harsh environments, including factories, motor vehicles, industrial equipment, military equipment, and on cellular antennae towers. In such environments, conventional connection assemblies often become unintentionally disconnected due to vibration, impact, temperature changes, and exposure to other harsh conditions. In addition, the connection between components may be negatively effected by the ingress of dust, dirt, moisture, and/or other contaminants. Fiber optic network segments are particularly vulnerable because fiber optic connections require extremely precise termination and alignment between connected components and cable segments. Accordingly, telecommunication network providers would benefit from a connection assembly capable of maintaining a secure connection and preventing the ingress of unwanted contaminants in harsh environments.

## SUMMARY

**[0003]** This disclosure is not limited to the particular systems, devices and methods described, as these may vary. The terminology used in the description is for the purpose of describing the particular versions or embodiments only, and is not intended to limit the scope.

**[0004]** As used in this document, the singular forms “a,” “an,” and “the” include plural references unless the context clearly dictates otherwise. Unless defined otherwise, all technical and scientific terms used herein have the same meanings as commonly understood by one of ordinary skill in the art. Nothing in this disclosure is to be construed as an admission that the embodiments described in this disclosure are not entitled to antedate such disclosure by virtue of prior invention. As used in this document, the term “comprising” means “including, but not limited to.”

**[0005]** In one aspect, a lockable connection component may comprise a coupling nut configured to rotatably couple the lockable connection component to a complementary mating component at a connection interface, the coupling nut having at least one locking collar interface; a connector body arranged within a longitudinal bore of the coupling nut and configured to be non-rotatably attached to the lockable connection component; and a locking collar having at least one coupling nut interface, the locking collar being configured to non-rotatably slide over the connector body and interface with the coupling nut such that the at least one coupling nut interface engages the at least one locking collar interface, thereby preventing the coupling nut from rotating and disconnecting from the complementary mating component.

**[0006]** In one aspect, a lockable connection component may comprise a coupling nut configured to rotatably couple the lockable connection component to a complementary mating component, the coupling nut having at least one connector body interface element; and a connector body configured to be non-rotatably attached to the lockable connection

component and arranged within a longitudinal bore of the coupling nut, the connector body having at least one coupling nut interface configured to be fixedly engaged by the at least one connector body interface element, thereby preventing the coupling nut from rotating and disconnecting from the complementary mating component.

**[0007]** In one aspect, a lockable connection component may comprise a coupling nut configured to rotatably couple the lockable connection component with a complementary mating component, the coupling nut having at least one slot; a connector body configured to be non-rotatably attached to the lockable connection component and having at least one external recess, the connector body being arranged within a longitudinal bore of the coupling nut such that the at least one slot corresponds with the at least one external recess; and a clip component having at least one protrusion, the clip component being configured to engage the coupling nut such that the at least one protrusion extends through the at least one slot and engages the at least one external recess, thereby preventing the coupling nut from rotating and disconnecting from the complementary mating component.

**[0008]** In one aspect, a lockable connection assembly may comprise a first connection component having a coupling nut configured to rotatably couple the first connection component with a second connection component, the coupling nut having at least one first slot and the second connection component having at least one second slot, wherein a gap exists between the coupled first connection component and second connection component; a clip component having at least one first protrusion and at least one second protrusion, the clip component being configured to be inserted within the gap such that the at least one first protrusion engages the at least one first slot and the at least one second protrusion engages the at least one second slot, thereby preventing the coupling nut from rotating and disconnecting from the second connection component.

## BRIEF DESCRIPTION OF THE DRAWINGS

**[0009]** The above and other objects of the present invention will become more readily apparent from the following detailed description taken in connection with the accompanying drawings.

**[0010]** FIGS. 1A–F depict various views of an illustrative fiber optic connection assembly.

**[0011]** FIGS. 2A–H depict various views of a lockable connector element according to a first locking collar embodiment.

**[0012]** FIGS. 2I–K depict various views of a lockable connector element according to a second locking collar embodiment.

**[0013]** FIGS. 2L–N depict various views of a lockable connector element according to a third locking collar embodiment.

**[0014]** FIGS. 3A–E depict a lockable connector element according to a flexible finger embodiment.

**[0015]** FIGS. 4A–C depict an illustrative lockable connector element according to a screw lock embodiment.

**[0016]** FIGS. 5A–D depict an illustrative lockable connector element according to some pin lock embodiments.

**[0017]** FIGS. 6A–I depict an illustrative lockable connector according to some C-clip embodiments.

**[0018]** FIGS. 7A–G depicts an illustrative lockable connection assembly according to some key lock embodiments.

**[0019]** FIGS. 8A–C depict an illustrative lockable connection assembly according to a pawl lock embodiment.

## DETAILED DESCRIPTION

**[0020]** The described technology generally relates to lockable connection assemblies for providing secure connections between cable segments and/or devices within a network. The network may include any type of network capable of transmitting signals, electricity, or any other type of transmission medium. For example, the network may include, without limitation, a communication network, a telecommunication network, an electrical network, a data network, a computer network, and any combination thereof. In some embodiments, the network may include a communication network using various signal transmission mediums, including, without limitation, fiber optic networks, Ethernet networks, cable and/or satellite television networks, and any other type of communication network now known or developed in the future. In some embodiments, the lockable connection assemblies may be configured to connect cable segments and/or devices within a fiber optic network using various standard connector types, including, but not limited to LC, ST, SC, FC, DIN, D4, SMA, E2000, Biconic, FullAXS, OCD, and/or MPO. In some embodiments, the lockable connection assemblies may be configured to meet various standards, such as the British Standards Institution (BSI), the Open DeviceNet Vendors Association (ODVA), and/or the like. In some embodiments, the lockable connection assemblies may be used with copper-type network connections, such as RJ-45 type connectors.

**[0021]** According to some embodiments, the lockable connection assemblies may be configured to lock a connection assembly connector (for instance, a plug, male connector, connector, or “lockable connector”) to a connection assembly adapter (for instance, a receptacle, female connector, adapter, or “lockable adapter”) (collectively, the “connection components” or “complementary mating components”), or vice versa. The lockable connection assemblies may be configured to lock the connection components to each other to prevent the disconnection and/or unintentional disconnection thereof. In some embodiments,

the lockable connection assemblies may be configured to provide a lock mechanism for connection components engaged to each other through conventional connection configurations. For example, a lockable connection assembly may be configured to lock connection elements engaged using a bayonet-type connection configuration, clips, tabs, plugs, or any other type of mechanical connection now known or developed in the future. In general, a lockable connection assembly may include any type of connection that requires intentional removal (for example, removal due to intentional human forces and not forces such as vibration, impact, or the like) in order to disconnect the connection components.

**[0022]** According to some embodiments, the lockable connectors may be configured to be coupled with the lockable adapters through a type of motion, such as rotation, axial motion, or some combination thereof. For example, a lockable connector may be coupled to a lockable adapter through an axial motion that forces a plug of the lockable connector to mate with a receptacle of the lockable adapter. In another example, a lockable connector may be coupled to a lockable adapter by rotating a shell, collar, coupling nut, or the like having bayonet locking buttons such that the bayonet locking buttons enter and slide along corresponding bayonet grooves of the lockable adapter. The lockable elements configured according to some embodiments may generally be configured to prevent the motion and/or reverse motion required to couple the lockable connector to the lockable adapter. For instance, in a bayonet-style connection assembly, lockable elements may be associated with the lockable connector and/or the lockable adapter to prevent rotation of the lockable connector and/or the lockable adapter to inhibit the unintentional disconnection of the lockable connector and the lockable adapter.

**[0023]** The described technology provides multiple technological advantages. A non-limiting example of an advantage is that the connection between connection components may be maintained in harsh environments in which the lockable connection assembly may be

subjected to forces due to such as vibrations, impact, temperature change, moisture, wind, or the like. Another non-limiting example of an advantage is that the lockable connection assembly may be configured to prevent the ingress of unwanted contaminants into the interior of the lockable connection assembly that may interfere with the connection between the connector and the adaptor. A further non-limiting example of an advantage is that the lockable connection assembly may be assembled using relatively low-cost components and locked with minimal labor, thereby providing a cost- and resource-efficient method of providing highly secure connections within a network.

**[0024]** FIGS. 1A–1C depict side views of an illustrative fiber optic connection assembly. As shown in FIG. 1A, a communication cable **102** may be terminated by connector **110** configured to connect to an adaptor **105**. The connector **110** may include duplex LC plug connectors **116** configured to be inserted into corresponding receptacles (not shown) in the adaptor **105** to form a continuous fiber optic connection with the optical connectors **114**. The fiber optic connection assembly may be configured to connect using a bayonet-type connection. As such, the adaptor component **106** of the adaptor **105** may include bayonet grooves **112** configured to receive bayonet lock buttons **108** arranged on the connector component **104** of the connector **110**. The adaptor **105** may be joined with the connector **110** using conventional bayonet connection methods. For example, the rotatable connector component **104** may be brought together with the adaptor component **106**, which may be non-rotatable, and rotated such that the bayonet lock buttons **108** enter the bayonet grooves **112**. As the connector component **104** is rotated, the bayonet lock buttons **108** may ride along the bayonet grooves **112**, axially drawing the connector **110** toward the adaptor **105** until the bayonet lock buttons **108** reach their respective button seats or bumps **118** in the bayonet grooves **112**. The bumps **118** may have various dimensions according to various standards, such as BIS standards, to accommodate the bayonet lock buttons **108** and to

facilitate the bayonet-type connection between the connector **110** and the adapter **105**. For example, the bumps **118** may have a height of about 0.2 millimeters to about 0.3 millimeters.

[0025] Conventional connection assemblies may include rudimentary elements configured to prevent rotation of the connector component **104** after the bayonet-type connection has been achieved (for example, once the bayonet lock buttons **108** have been seated in the bumps **118**). FIGS. 1D and 1E depict an ODVA key mechanism configured to prevent rotation of the connector component **104** after being connected to the adapter component **106** through the bayonet connection. FIG. 1D depicts a front view of the adapter **105** through line A-A of FIG. 1C. As shown in FIG. 1D, an internal surface of the adapter component **106** may include an adapter key **120** configured to engage a key slot **122** of the connector component **104** as depicted in FIG. 1E (showing the connector **110** through the line B-B of FIG. 1C). When the connector **110** is coupled to the adapter **105**, the adapter key **120** may fit into the key slot **122** to prevent rotation of the connector component **104** and release of the bayonet-type connection. FIG. 1F depicts the connector **110** coupled to the adapter **105** using the bayonet-type connection and the ODVA key mechanism.

[0026] FIGS. 2A and 2B depict a lockable connector element according to a first locking collar embodiment. As shown in FIGS. 2A and 2B, the lockable connector **200** may be a connector configured to connect plug **116** to a receptacle of an adapter (not shown). Although a connector (plug or male connector) is depicted FIGS. 2A and 2B, and is used in some other embodiments herein, lockable connector elements are not so limited, as adapters may also be configured as lockable connector elements. The lockable connector **200** and portions thereof may be made from various resilient materials, such as plastics, polymers, rubber, silicon-based materials, metals, metal alloys, and any combination thereof.

[0027] The lockable connector **200** may include a connector body **208** configured to be threaded onto a compression fitting **202** of an optical fiber cable **102**. The connector body

**208** may be arranged within a longitudinal bore of a coupling nut **206** that may rotate about the connector body. In some embodiments, once the connector body **208** has been threaded onto the compression fitting **202**, the connector body may be immobile or substantially immobile (for instance, will not rotate or will not rotate in one direction only). A flange **216** may be arranged at a proximal end of the connector body **208** (proximal with respect to the connection between the connector **200** and the adapter) that is configured to engage the inside of the coupling nut **206** to prevent the coupling nut from sliding off of the proximal end of the connector body. The coupling nut **206** may include one or more bayonet locking buttons **108** configured to engage complementary bayonet grooves of an adapter to couple the lockable connector **200** thereto.

[0028] The lockable connector **200** may include a locking collar **204** configured to engage the coupling nut **206** and to prevent the rotation of the coupling nut when the lockable connector is attached to the adapter through the bayonet-type connection. The connector body **208** may include a locking collar interface **212** (the “connector body locking collar interface”) configured to engage with a corresponding connector body interface **214** of the locking collar **204** to prevent rotation of the locking collar about the connector body. As such, the locking collar **204** may slide over the connector body **208**, but may not rotate over the connector body. In some embodiments, the locking collar interface **212** and the connector body interface **214** may be formed as corresponding flat surfaces.

[0029] The coupling nut **206** may include a locking collar interface **218** (the “coupling nut locking collar interface”) configured to engage with a coupling nut interface **210** of the locking collar and prevent rotation of the coupling nut **206**. In some embodiments, the coupling nut interface **210** and the locking collar interface **218** may be formed as corresponding flat surfaces. When the coupling nut **206** has formed a bayonet-type connection with the adapter, the locking collar **204** may slide over the connector body **208**

and engage the coupling nut **206** such that the coupling nut interface **210** enters into the interior of the coupling nut and engages with the locking collar interface **218**, thereby preventing the coupling nut **206** from rotating and disconnecting from the adapter. FIG. 2C depicts a side view of the assembled, unlocked locking connector **200** and FIG. 2D depicts a side view of the assembled locking connector **200** locked and connected to an adapter **220**.

[0030] Although the locking collar interface **212**, the connector body interface **214**, coupling nut interface **210**, the locking collar interface **218**, and other similar interfaces described herein are depicted as being flat surfaces, embodiments are not so limited, as the interfaces may include any configuration capable of allowing one element to engage (for example, prevent rotation or other movement of) another element, including protrusions, raised elements, tabs, slots, flanges, fasteners, pins, or the like.

[0031] In some embodiments, the locking collar **204**, the connector body **208**, and/or the coupling nut **206** may include one or more elements configured to prevent the locking collar from sliding out of engagement with the coupling nut. In some embodiments, the locking collar **204**, the connector body **208**, and/or the coupling nut **206** may include at least one raised feature configured to be seated within a corresponding recess in another of the locking collar, the connector body, and/or the coupling nut to prevent movement of the locking collar once the locking connector **200** is locked. FIG. 2E depicts an illustrative locking collar configured to prevent movement of the locking collar through line A-A of FIG. 2D. As shown in FIG. 2E, the surface of the coupling nut interface **210** of the locking collar **204** may include at least one raised element **222** corresponding to at least one recess **224** arranged in the locking collar interface **118** of the coupling nut **206**.

[0032] According to some embodiments, the locking collar **204** may be pushed into the interior of the coupling nut **206**, engaging the at least one raised element **222** with the external surface of the locking collar interface **218** and forcing the locking collar interface to

move away from the coupling nut interface **210** until the at least one raised element is seated in the at least one recess **224**. Seating (or “snapping”) the at least one raised element **222** into the at least one recess **224** may operate to prevent the locking collar **204** from moving away from the coupling nut **206**. FIG. 2F depicts an illustrative locking collar **204** showing a raised element **222** and the connector body interface **214**.

[0033] FIGS. 2G and 2H depict a lockable connector element according to a second locking collar embodiment. As shown in FIGS. 2G and 2H, the locking collar interface **218** of the coupling nut **206** may be located on an external surface of the coupling nut, for instance, at a distal end thereof. The locking collar **204** may include an internal coupling nut interface **210** configured to engage the locking collar interface **218** of the coupling nut **206**. In this manner, the coupling nut interface **210** may non-rotatably slide over the connector body **208** and engage the locking collar interface **218** and prevent rotation of the coupling nut **206** and, therefore, disconnection of the lockable connector **200** from the adapter. FIG. 2I depicts the assembled lockable connector **200** coupled to the adapter **220** and unlocked. FIG. 2J depicts the assembled connector **200** coupled to the adapter **220** in which the locking collar **204** has moved over the connector body **208** and engaged the coupling nut **206** to lock the lockable connector **200**.

[0034] As shown in FIG. 2I, the connector body **208** may include at least one raised element **222**. FIG. 2K depicts the portion of the lockable connector **200** through line A-A of FIG. 2I. The locking collar **204** may be configured to move over the raised element **222** when engaging the coupling nut **206** when the coupling nut has formed a bayonet-type connection with the adapter **220**. Once the locking collar **204** moves past the raised element **222**, the locking collar is prevented from moving proximally away from the coupling nut **206** and unlocking the locked connector body **208**.

[0035] In this manner, the coupling nut interface **210** may slide over and engage the locking collar interface **218** and prevent rotation of the coupling nut **206** and, therefore, disconnection of the lockable connector **200** from the adapter. FIG. 2I depicts the assembled lockable connector **200** coupled to the adapter **220** and unlocked. FIG. 2J depicts the assembled connector **200** coupled to the adapter **220** in which the locking collar **204** has moved over the connector body **208** and engaged the coupling nut **206** to lock the lockable connector **200**.

[0036] FIGS. 2L and 2M depict a lockable connector element according to a third locking collar embodiment. As shown in FIGS. 2L and 2M, the locking collar **204** may be configured as a split-lock collar including two collar portions **226a**, **226b** that may be fastened together using one or more fasteners **228a**, **228b**, such as screws (for instance, set screws, wing-nut type screws, or the like). When fastened, the split-lock collar **204** may form a coupling nut interface **210** configured to engage a locking collar interface **218** located on an external surface of the coupling nut **206**, for instance, at a distal end thereof. When fastened, the split-lock collar **204** may also form a connector body interface **214** configured to engage a locking collar interface **212** located on an external surface of the connector body **208**.

[0037] The locking collar **204**, when fastened, may be configured to non-rotatably slide over the connector body **208** and engage the coupling nut **206** or may be fastened directly in engagement with the coupling nut. The locking collar interface **212** may engage the connector body interface **214** and prevent the fastened locking collar **204** from rotating about the connector body **208**. The coupling nut interface **210** may engage the locking collar interface **218** and prevent the coupling nut **206** from rotating and disconnecting the lockable connector **200** from the adapter **220**. FIG. 2N depicts the lockable connector **200** connected to the adapter **220** and locked to prevent rotation of the coupling nut **206**.

[0038] FIGS. 3A and 3B depict a lockable connector element according to a flexible finger embodiment. As shown in FIGS. 3A and 3B, the lockable connector **200** may include a coupling nut **306** having one or more flexible fingers **302** arranged at a proximal end thereof. In some embodiments, the one or more flexible fingers **302** may be biased to press inward toward the central axis of the coupling nut **306**. In some embodiments, the flexible fingers **302** may be collet fingers. In some embodiments, the flexible fingers **302** may each include a flange **310** extending inward toward the central axis of the coupling nut **306**. A connector body **308** may be configured to be arranged within a longitudinal bore of the coupling nut **306**. The connector body **308** may have one or more recesses **304** configured to correspond with the one or more flexible fingers.

[0039] In FIG. 3C, the coupling nut **306** is being rotated about the connector body **308** as the bayonet locking buttons (not shown) are sliding within the bayonet groove (not shown) of the adapter **220**. Before the bayonet-type connection is formed, the flexible fingers **304** may bend or flex outward (for instance, away from the connector body **308**), allowing the coupling nut **306** to rotate on the connector body **308**. Referring to FIG. 3D, the coupling nut **306** has formed the bayonet-type connection with the adapter **220**. As such, the coupling nut **306** has moved proximally along the connector body **308** such that the one or more flexible fingers **302** have been seated in the one or more recesses **304**. In this arrangement, the one or more flexible fingers **302** are pressing inward against the inner surfaces of the one or more recesses, thereby preventing rotation of the coupling nut **306** and disconnection of the lockable connector **200** with the adapter **220**.

[0040] According to some embodiments, various additional locking elements may be configured to enhance the security of the lock formed between the coupling nut **306** and the connector body **308**. For example, a band may be arranged around the outer surfaces of the one or more flexible fingers **304** to provide inward pressure (for instance, pressure toward the

center of the coupling nut **306**) to prevent the one or more flexible fingers from being moved outward (for instance, away from the connector body **308**). FIG. 3E depicts a standard electrical cable tie **312** being affixed to the lockable connector **200** around the one or more flexible fingers **304**. The cable tie **312** may prevent the one or more flexible fingers **304** from moving outward and weakening the lock formed between the coupling nut **306** and the connector body **308**.

[0041] FIGS. 4A and 4B depict an illustrative lockable connector element according to a screw lock embodiment. A coupling nut **406** may be configured to couple the locking connector **200** with an adapter using a bayonet-type connection. The coupling nut **406** may be associated with a locking element **410** configured to engage a locking element interface **412** of the connector body **408**. The locking element **410** may include a screw or other similar fastener configured to engage the coupling nut **406** through a corresponding opening **414**. For instance, the opening **414** may include a threaded opening configured to receive a screw-type locking element **410**.

[0042] FIG. 4B depicts the lockable connector **200** coupled to an adapter **220**. When the bayonet-type connection between the lockable connector **200** and the adapter **220** has been formed, the screw-type locking element **410** may be rotated into the corresponding threaded opening **414**, passing through the coupling nut **406** and engaging the locking element interface **412** of the connector body **408**. The screw-type locking element **410** may press against the locking element interface **412** while a portion of the screw-type interface element remains within the threaded opening **414** engaging the coupling nut **406**, thereby locking the lockable connector **200** by inhibiting rotation of the coupling nut and preventing disconnection of the lockable connector **200** from the adapter **220**. FIG. 4C depicts an embodiment in which the screw-type locking element **410** is formed as a wing nut fastener that may be finger-tightened such that tools are not necessary to lock and/or unlock the

lockable connector **200**. In some embodiments, the lockable connector **200** may be unlocked from the adapter **220** by removing the connector body locking element **410** (for instance, sufficiently unscrewing or removing the screw-type locking element from the opening).

[0043] FIG. 5A depicts an illustrative lockable connector element according to a pin lock embodiment. As shown in FIG. 5A, a locking element **512** may be configured to be inserted through one or more openings **510a**, **510b** (opening **510b** shown in FIG. 5D) in the coupling nut **506**. The locking element **512** may include a key, pin, or other element capable of being inserted through openings **510a**, **510b** and engage a locking element interface **504** of the connector body **508**.

[0044] In an embodiment, the locking element **512** may include a cable tie. FIG. 5B depicts a method of locking a lockable connector **200** using a cable tie connector locking element **512**. As shown in step **520** of FIG. 5B, the lockable connector **200** may be coupled to an adapter **220**, for instance, through a bayonet-type connection. In step **525**, the cable tie **512** may be inserted through openings **510a**, **510b**. The cable tie **512** may engage a portion of the locking element interface **504** (see FIG. 5D) arranged within the coupling nut **506** and prevent rotation of the coupling nut about the connector body **508**. In step **530**, the cable tie **512** may be tied off to prevent movement, removal, or the like of the cable tie from the lockable connector **200**.

[0045] FIG. 5C depicts a side view of a lockable connector **200** coupled to an adapter **220** according and locked using a cable tie **512** according to some embodiments. FIG. 5D provides an internal front view of a portion of the lockable connector **200** coupled to the adapter **220** through the line A-A of FIG. 5C. As shown in FIG. 5D, the coupling nut **506** may include at least one connector body interface **514** arranged therein and configured to engage at least one locking element interface **504** of the connector body **508**. The cable tie **512** may be inserted through openings **510a**, **510b** and engage another locking element

interface **504**. In this manner, the connector body interface **514** and the cable tie **512** may both engage at least one locking element interface **504** to prevent the coupling nut **506** from rotating and disconnecting from the adapter **520**.

**[0046]** FIG. 6A depicts an illustrative lockable connector according to a C-clip embodiment. As shown in FIG. 6A, the lockable connector **200** may include a coupling nut **606** having at least one opening **610**. A connector body **608** may be arranged within a longitudinal bore of the coupling nut **606** and may include at least one opening **616** corresponding to the coupling nut opening **610**. In some embodiments, the coupling nut opening **610** and the connector body opening **616** may be configured as a slot, a recess, a hole, or a combination thereof. A C-clip **612** may be configured to be clipped around at least a portion of the coupling nut **606**. The C-clip **612** may have at least one protrusion **614** formed on an inside surface of the C-clip and configured to correspond with the coupling nut opening **610** and the connector body opening **616**.

**[0047]** The coupling nut **606** may be coupled to an adapter (not shown) as described according to some embodiments. The coupling nut **606** may be arranged such that the connector body opening **616** or at least a portion thereof is accessible through the coupling nut opening **610**. As shown in FIGS 6B and 6C, the C-clip **612** may be inserted (or “snapped”) onto overlapping portions of the coupling nut **606** and the connector body **608** such that the protrusion **614** extends through the coupling nut opening **610** and down into the connector body opening **616**. The connector body **608** may be threaded onto the compression fitting **220** such that the connector body does not rotate. The positioning of the protrusion **614** in the connector body opening **616** prevents the C-clip **612** from being able to rotate about the connector body **608**. As the protrusion **614** also passes through the coupling nut opening **610**, the protrusion also prevents the coupling nut **606** from rotating and disconnecting from the adapter.

[0048] Referring to FIG. 6C, some embodiments provide a lanyard connector **620** arranged on the C-clip **612**. The lanyard connector **620** may be attached to a lanyard **618** or other connection element that is also connected to the communication cable **102**. In this manner, the C-clip **612** may be maintained in proximity to the lockable connector **200** when unattached from the coupling nut **606** and connector body **608**.

[0049] FIG. 6D depicts a front view of an illustrative C-clip **612** according to some embodiments. FIG. 6E depicts a front view of a lockable connector **200** having a C-clip **612** connected thereto and FIG. 6F depicts a cross-sectional view of the lockable connector through the line A-A of FIG. 6E. As shown in FIG. 6F, the protrusion **614** may be simultaneously locked into the connector body **608** and the coupling nut **606**, thereby preventing the coupling nut from rotating about the connector body.

[0050] FIG. 6G depicts an illustrative lockable connection assembly according to a C-clip embodiment. As shown in FIG. 6G, a connection assembly **605** may include a lockable adapter **622** configured to connect with the coupling nut **606** of the lockable connector **600**, for example, through a bayonet-type connector. The lockable adapter **622** may include at least one adapter slot **624** and the coupling nut **606** may include at least one corresponding connector slot **626**. The connection assembly **605** may include at least one C-clip **612** having protrusions **614** that correspond with the at least one adapter slot **624** and the at least one connector slot **626**.

[0051] FIG. 6H depicts an assembled lockable connector **600** coupled to an assembled lockable adapter **622**. As shown in FIG. 6H, when the lockable connector **600** is coupled to the assembled lockable adapter **622**, a gap **628** may be arranged therebetween. The gap **628** may be configured to provide sufficient space for the C-clip **612** to be clipped (or “snapped”) between the lockable adapter **622** and the lockable connector **600** such that the protrusions **614** are positioned within the at least one adapter slot **624** and the at least one

connector slot **626**. The C-clip **612** may operate to engage the at least one adapter slot **624** and the at least one connector slot **626** to lock the coupling nut **606** to the lockable adapter **622**, thereby preventing the unintentional de-coupling of the lockable adapter **622** and the lockable connector **600**. FIG. 6I depicts the assembled lockable connector **600** coupled to an assembled lockable adapter **622** in which the lanyard **618** is connected to the lanyard connector **620** and to the communication cable **102**.

[0052] FIG. 7A depicts an illustrative lockable connection assembly according to a first key lock embodiment. As shown in FIG. 7A, a lockable connection assembly **705** may include a lockable connector **700** having a coupling nut **706** arranged about a connector body **708** and configured to connect with a lockable adapter **722** through a bayonet-type connection. The coupling nut **706** may include at least one key **730** configured to be extended to lock the lockable connection assembly **700** and to be retracted to unlock the lockable connection assembly **705** (see FIG. 7B). The at least one key **730** may be configured as a spring-loaded protrusion that may slide toward the lockable adapter **722**. FIG. 7B depicts the coupling nut **706** with the spring-loaded key **730** in the retracted position **740** and the extended position **742**.

[0053] The lockable adapter **722** may include at least one slot **710** configured to receive the at least one extended spring-loaded key **730**. When the lockable connector **700** is coupled to the lockable adapter **722**, the spring-loaded key **730** may be extended and may engage the at least one slot **710**. As the lockable adapter **722** is stationary (for instance, cannot rotate), the spring-loaded key **730** operates to prevent the coupling nut **706** from rotating and disconnecting the lockable connector **700** from the lockable adapter **722**. FIG. 7C depicts the lockable connection assembly **700** with the spring-loaded key **730** in the retracted position and FIG. 7D depicts the lockable connection assembly with the key in the extended (or engaged) position. In FIG. 7C, the lockable connector **200** is coupled to the

lockable adapter **722**; however, the coupling nut **706** is free to rotate about the connector body **708**. In FIG. 7C, the lockable connector **700** is coupled to the lockable adapter **722** and rotation of the coupling nut **706** is prevented because the spring-loaded key **730** is engaged with the slot **710**.

[0054] FIG. 7E depicts an illustrative lockable connection assembly according to a second key lock embodiment. As shown in FIG. 7E, the at least one key **730** may be configured as a screw-type key that may be rotated to extend the key into at least one slot **710** of the lockable adapter **722**. When the lockable connector **700** is coupled to the lockable adapter **722**, the screw-type key **730** may be extended and may engage the at least one slot **710**. As the lockable adapter **722** is stationary (for instance, cannot rotate), the screw-type key **730** operates to prevent the coupling nut **706** from rotating and disconnecting the lockable connector **700** from the lockable adapter **722**. FIG. 7F depicts the lockable connection assembly **705** with the key screw-type **730** in the retracted position and FIG. 7G depicts the lockable connection assembly **705** with the key in the extended (or engaged) position. In FIG. 7F, the lockable connector **700** is coupled to the lockable adapter **722**; however, the coupling nut **706** is free to rotate about the connector body **708**. In FIG. 7G, the lockable connector **700** is coupled to the lockable adapter **722** and rotation of the coupling nut **706** is prevented by the screw-type key **730** being engaged with the slot **710**.

[0055] Although the key **730** is depicted as being a spring-loaded or screw-type key in FIGS. 7A-7G, lockable connection assemblies **705** are not so limited as any type of key may be used according to some embodiments described herein. For instance, the key **730** may be configured as a flange, pin, peg, or fastener capable of fixedly engaging the slot **710**.

[0056] FIG. 8A depicts an illustrative lockable connection assembly according to a pawl lock embodiment. As shown in FIG. 8A, a lockable connection assembly **805** may include a lockable adapter **822** configured to receive a pawl latch **840**. The lockable adapter

**822** may include at least one adapter slot (or groove) **810** corresponding to at least one protrusion **842** arranged on an internal surface of the pawl latch **840**. The pawl latch **840** may be positioned around the lockable adapter **822** such that the at least one protrusion **842** engages the at least one adapter slot **810** to prevent the pawl latch **840** from rotating about the lockable adapter **822**.

[0057] The lockable connection assembly **805** may include a lockable connector **800** having a coupling nut **806** arranged about a connector body **808** and configured to connect the lockable connector to the lockable adapter **822**, for example, through a bayonet-style connection. The coupling nut **806** may include at least one coupling nut slot **812** corresponding to at least one tab or protrusion **844** (for instance, a flexible flange) extending from the pawl latch **840** and toward the lockable connector **800** when the lockable connector is coupled to the lockable adapter **822**. As shown in FIG. 8B, the at least one tab **844** may be extended away from the coupling nut **806** in an unlocked position.

[0058] Referring to FIG. 8C, the at least one tab **844** may be released and may engage the coupling nut slot **812** to lock the lockable connector **800** to the lockable adapter **822**. The at least one tab **844** may be configured to be biased toward the center of the pawl latch **840**. As shown in FIGS. 8B and 8C, the coupling nut slot **812** may form an axial engagement surface **826** that may engage the at least one tab **844** responsive to the lockable connector **800** being pulled in a direction away from the lockable adapter **822**. The coupling nut slot **812** may also form radial engagement surfaces **828** that may engage the at least one tab **844** responsive to an attempt to rotate the coupling nut **806**, therefore preventing the coupling nut from rotating and disconnecting from the lockable adapter **822**.

[0059] The locking of the connection components and connection assemblies according to some embodiments also operates to prevent the ingress of contaminants into the connection interface.

**[0060]** Although a fiber optic connector has been used as an illustrative embodiment, this detailed description is not so limited, as any type of electrical and/or communication connector may be used according to some embodiments. The connectors, adapters, and lockable components thereof may be used in combination with other connection elements and/or materials, such as crimpers, bands, straps, ferrules, locking materials, fluids, gels, or the like.

**[0061]** It will be appreciated that various of the above-disclosed and other features and functions, or alternatives thereof, may be desirably combined into many other different systems or applications. It will also be appreciated that various presently unforeseen or unanticipated alternatives, modifications, variations or improvements therein may be subsequently made by those skilled in the art which alternatives, variations and improvements are also intended to be encompassed by the following claims.

## CLAIMS

*What Is Claimed Is:*

1. A lockable connection component comprising:
  - a coupling nut configured to rotatably couple the lockable connection component to a complementary mating component at a connection interface, the coupling nut having at least one locking collar interface;
  - a connector body arranged within a longitudinal bore of the coupling nut and configured to be non-rotatably attached to the lockable connection component; and
  - a locking collar having at least one coupling nut interface, the locking collar being configured to non-rotatably slide over the connector body and interface with the coupling nut such that the at least one coupling nut interface engages the at least one locking collar interface, thereby preventing the coupling nut from rotating and disconnecting from the complementary mating component.
2. The lockable connection component of claim 1, wherein the locking collar comprises at least one raised element arranged on the at least one coupling nut interface,
  - wherein the coupling nut comprises at least one recess complementary to the at least one raised element,
  - wherein the at least one raised element is seated in the at least one recess when the at least one coupling nut interface engages the at least one locking collar interface, thereby preventing the locking collar from moving away from the coupling nut.
3. The lockable connection component of claim 1, wherein the at least one locking collar interface and the at least one coupling nut interface are formed as complementary flat surfaces.
4. The lockable connection component of claim 1, wherein the at least one coupling nut interface comprises at least one external flat surface of the locking collar,
  - wherein the at least one locking collar interface comprises at least one internal flat surface of the coupling nut.

5. The lockable connection component of claim 1, wherein the at least one coupling nut interface comprises at least one internal flat surface of the locking collar,  
wherein the at least one locking collar interface comprises at least one external flat surface of the coupling nut.
6. The lockable connection component of claim 1, wherein the lockable connection component is a fiber optic connection component.
7. The lockable connection component of claim 1, wherein the lockable connection component is an Open DeviceNet Vendors Association compliant connection component.
8. The lockable connection component of claim 1, wherein the lockable connection component is a lockable connector.
9. The lockable connection component of claim 1, wherein the lockable connection component is a lockable adapter.
10. The lockable connection component of claim 1, wherein the coupling nut connects the lockable connection component to the complementary mating component through a bayonet-type connection.
11. A lockable connection component comprising:  
a coupling nut configured to rotatably couple the lockable connection component to a complementary mating component, the coupling nut having at least one connector body interface element; and  
a connector body configured to be non-rotatably attached to the lockable connection component and arranged within a longitudinal bore of the coupling nut, the connector body having at least one coupling nut interface configured to be fixedly engaged by the at least one connector body interface element, thereby preventing the coupling nut from rotating and disconnecting from the complementary mating component.

12. The lockable connection component of claim 11, wherein the at least one connector body interface element comprises at least one flexible finger formed on the coupling nut, wherein the at least one coupling nut interface comprises at least one recess configured to engage at least a portion of the at least one flexible finger.
13. The lockable connection component of claim 11, wherein the at least one connector body interface element comprises at least one fastener configured to be affixed to the coupling nut and to extend through the coupling nut and engage the at least one coupling nut interface.
14. The lockable connection component of claim 13, wherein the at least one fastener is a set screw.
15. The lockable connection component of claim 13, wherein the at least one fastener is a spring-loaded screw.
16. The lockable connection component of claim 11, wherein the at least one connector body interface element comprises a cable tie, wherein the coupling nut comprises two openings configured to receive the cable tie such that at least a portion of the cable tie is arranged within an internal area of the coupling nut, wherein the at least one coupling nut interface comprises a flat surface configured to engage the at least a portion of the cable tie.
17. The lockable connection component of claim 11, wherein the lockable connection component is a fiber optic connection component.
18. The lockable connection component of claim 11, wherein the lockable connection component is an Open DeviceNet Vendors Association compliant connection component.
19. The lockable connection component of claim 11, wherein the lockable connection component is a lockable connector.

20. The lockable connection component of claim 11, wherein the lockable connection component is a lockable adapter.
21. The lockable connection component of claim 11, wherein the coupling nut connects the lockable connection component to the complementary mating component through a bayonet-type connection.
22. A lockable connection component comprising:  
a coupling nut configured to rotatably couple the lockable connection component with a complementary mating component, the coupling nut having at least one slot;  
a connector body configured to be non-rotatably attached to the lockable connection component and having at least one external recess, the connector body being arranged within a longitudinal bore of the coupling nut such that the at least one slot corresponds with the at least one external recess; and  
a clip component having at least one protrusion, the clip component being configured to engage the coupling nut such that the at least one protrusion extends through the at least one slot and engages the at least one external recess, thereby preventing the coupling nut from rotating and disconnecting from the complementary mating component.
23. The lockable connection component of claim 22, wherein the lockable connection component is a fiber optic connection component.
24. The lockable connection component of claim 22, wherein the lockable connection component is an Open DeviceNet Vendors Association compliant connection component.
25. The lockable connection component of claim 22, wherein the lockable connection component is a lockable connector.
26. The lockable connection component of claim 22, wherein the lockable connection component is a lockable adapter.

27. The lockable connection component of claim 22, wherein the coupling nut connects the lockable connection component to the complementary mating component through a bayonet-type connection.
28. A lockable connection assembly comprising:  
a first connection component having a coupling nut configured to rotatably couple the first connection component with a second connection component, the coupling nut having at least one first slot and the second connection component having at least one second slot, wherein a gap exists between the coupled first connection component and second connection component;  
a clip component having at least one first protrusion and at least one second protrusion, the clip component being configured to be inserted within the gap such that the at least one first protrusion engages the at least one first slot and the at least one second protrusion engages the at least one second slot, thereby preventing the coupling nut from rotating and disconnecting from the second connection component.
29. The lockable connection assembly of claim 28, wherein the lockable connection assembly is a fiber optic connection assembly.
30. The lockable connection assembly of claim 28, wherein the lockable connection lockable connection assembly is an Open DeviceNet Vendors Association compliant connection lockable connection assembly.
31. The lockable connection assembly of claim 28, wherein the first connection component is a lockable connector.
32. The lockable connection assembly of claim 28, wherein the second connection component is a lockable adapter.
33. The lockable connection assembly of claim 28, wherein the coupling nut connects the first connection component to the second connection component through a bayonet-type connection.

34. A lockable connection assembly comprising:  
a first connection component having a coupling nut configured to rotatably couple the first connection component with a second connection component, the coupling nut having at least one groove and the second connection component having at least one slot;  
a latch component having at least one first protrusion arranged on an inside surface thereof and at least one second protrusion arranged on an external surface thereof, the latch component being arranged between the first connection component and the second connection component such that the at least one first protrusion is arranged within the at least one groove and the at least one second protrusion is arranged within the at least one slot, thereby preventing the coupling nut from rotating and disconnecting from the second connection component.
35. The lockable connection assembly of claim 34, wherein the latch component is a pawl latch.
36. The lockable connection assembly of claim 34, wherein the at least one second protrusion is a flexible flange.
37. The lockable connection assembly of claim 34, wherein the lockable connection assembly is a fiber optic connection assembly.
38. The lockable connection assembly of claim 34, wherein the lockable connection assembly is an Open DeviceNet Vendors Association compliant lockable connection assembly.
39. The lockable connection assembly of claim 34, wherein the first connection component is a lockable connector.
40. The lockable connection assembly of claim 34, wherein the second connection component is a lockable adapter.

41. The lockable connection assembly of claim 34, wherein the coupling nut connects the first connection component to the second connection component through a bayonet-type connection.

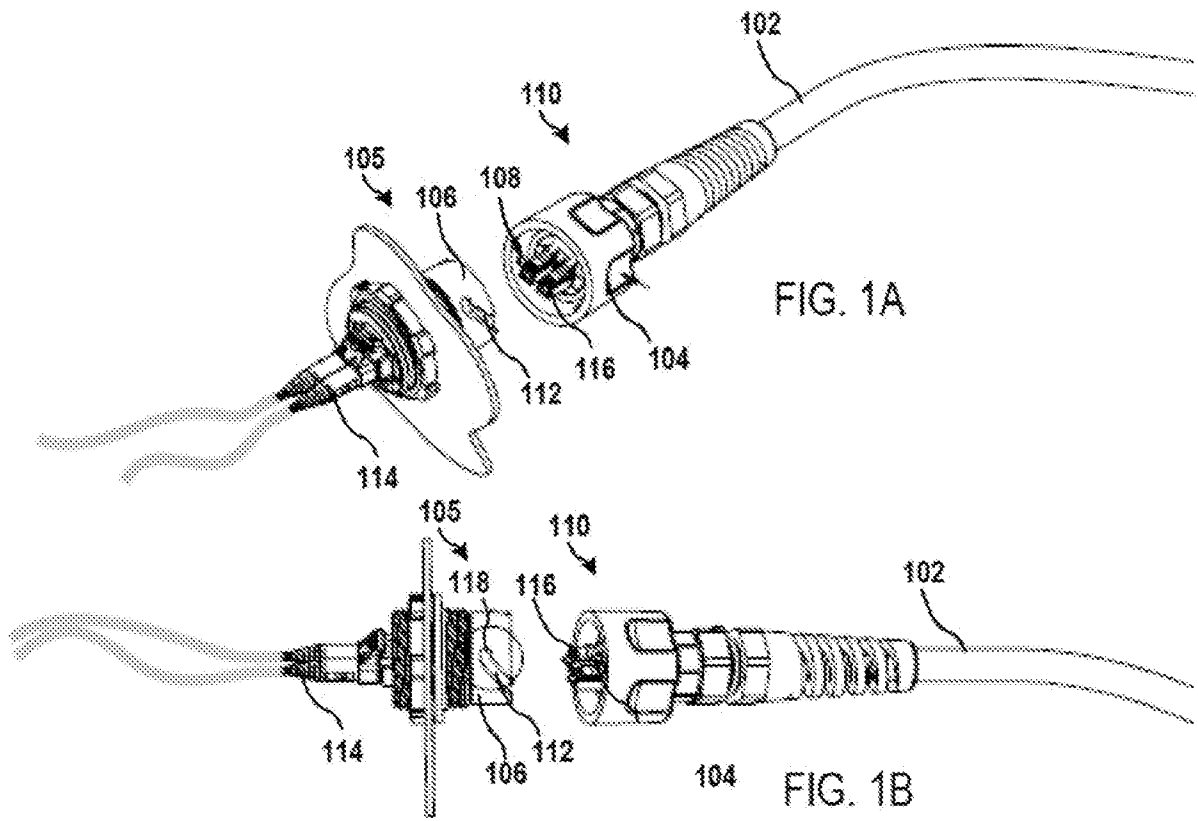

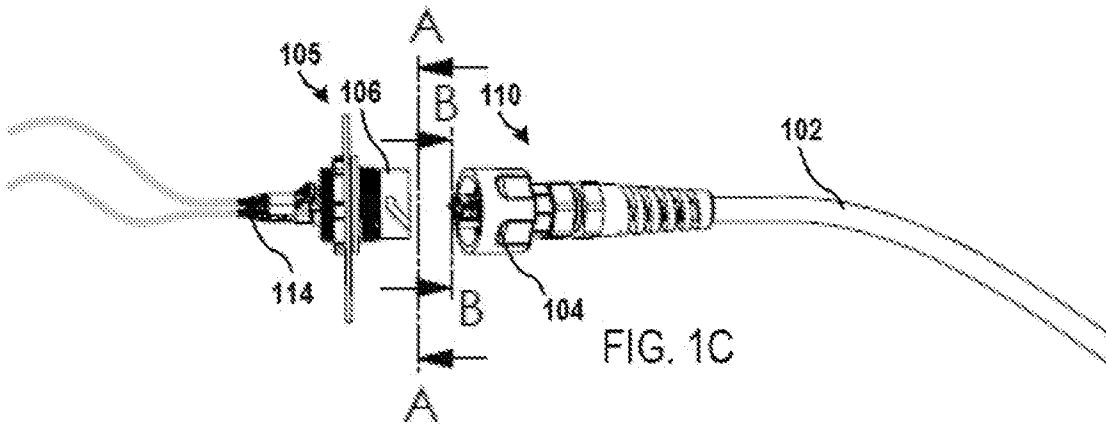

FIG. 1C

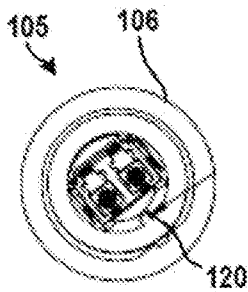

FIG. 1D

VIEW A-A

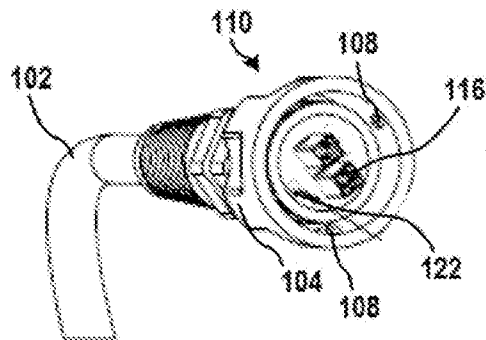

FIG. 1E

VIEW B-B

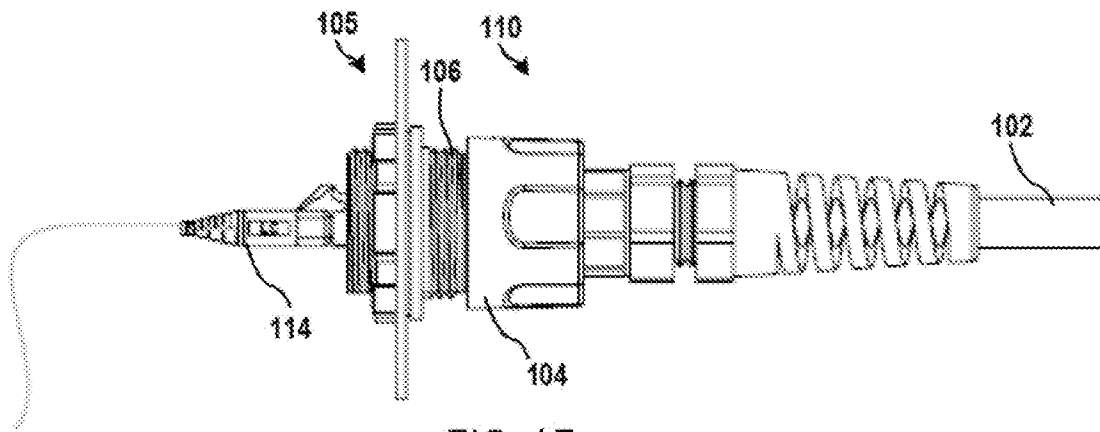

FIG. 1F

4/25

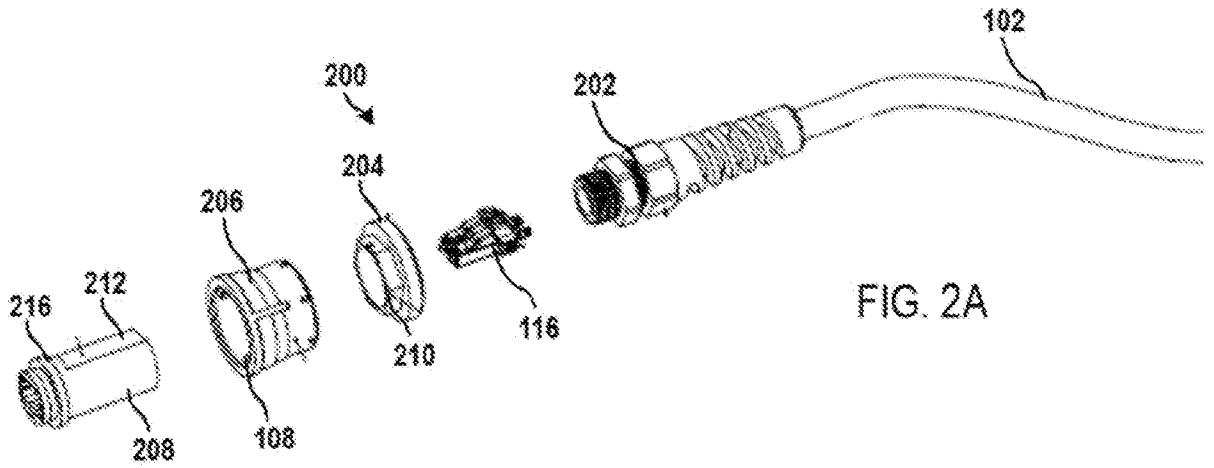

FIG. 2A

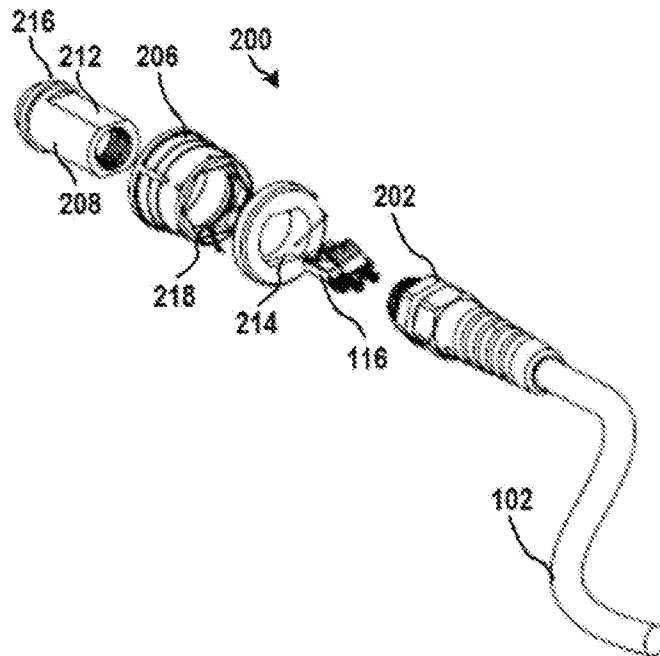

FIG. 2B

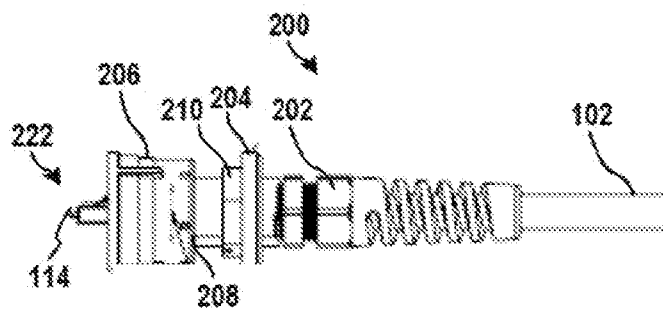
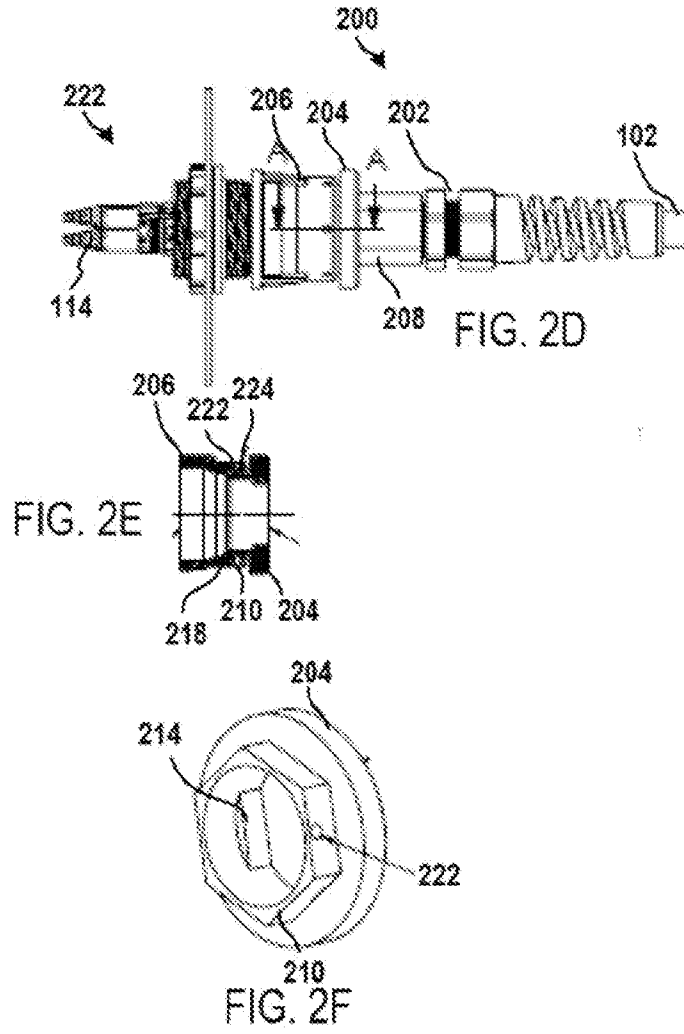

FIG. 2C

6/25



7/25

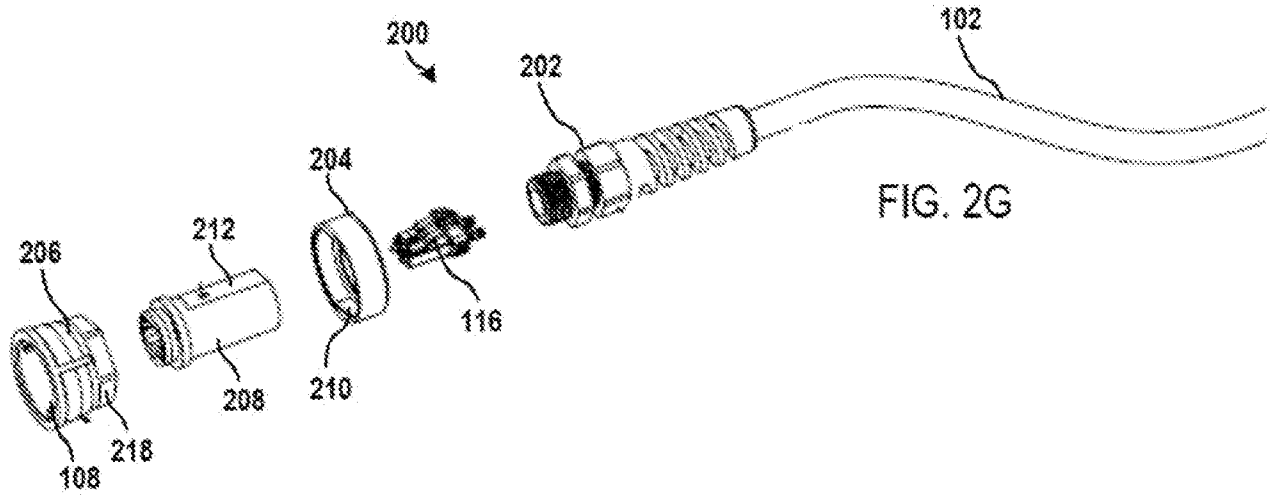

FIG. 2G

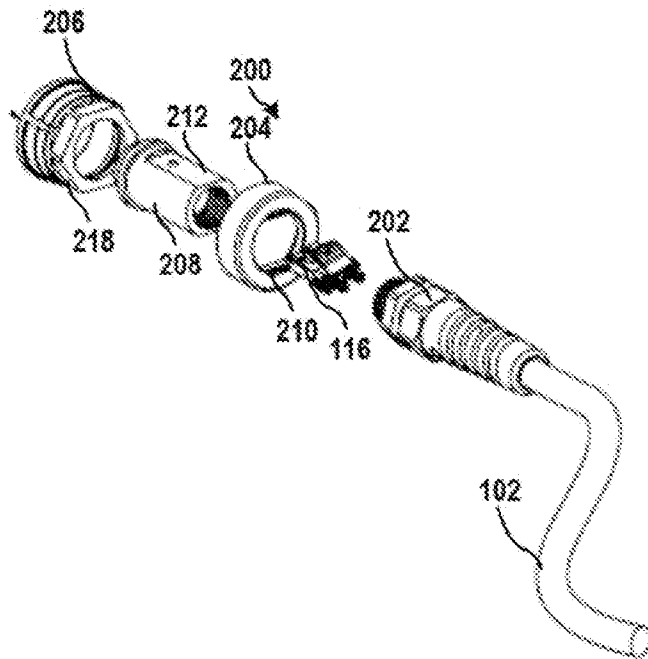

FIG. 2H

8/25

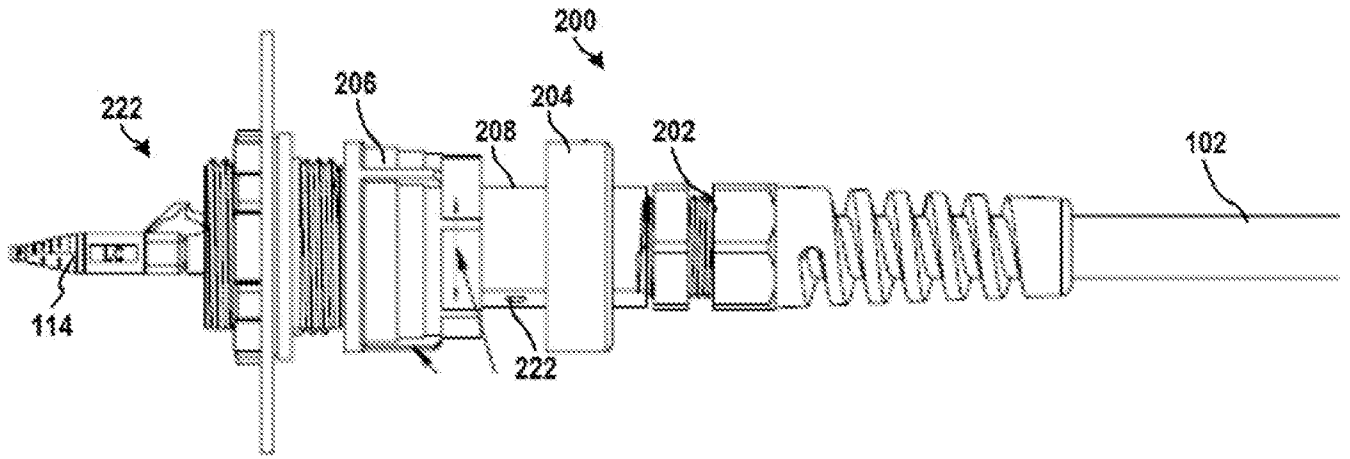

FIG. 21

9/25

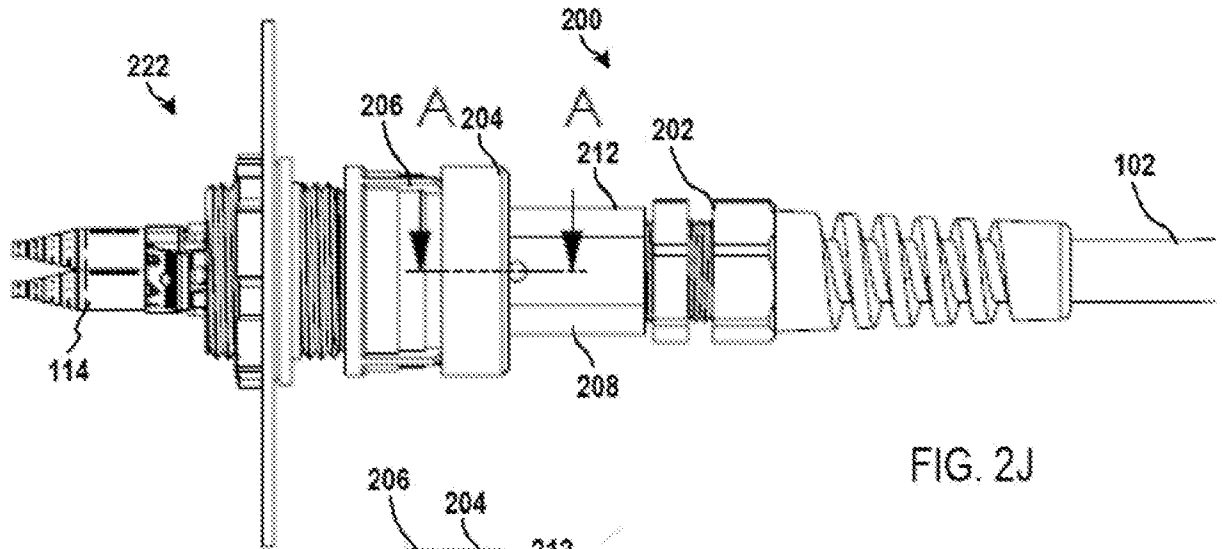

FIG. 2J

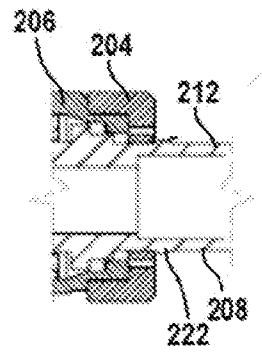

FIG. 2K

10/25

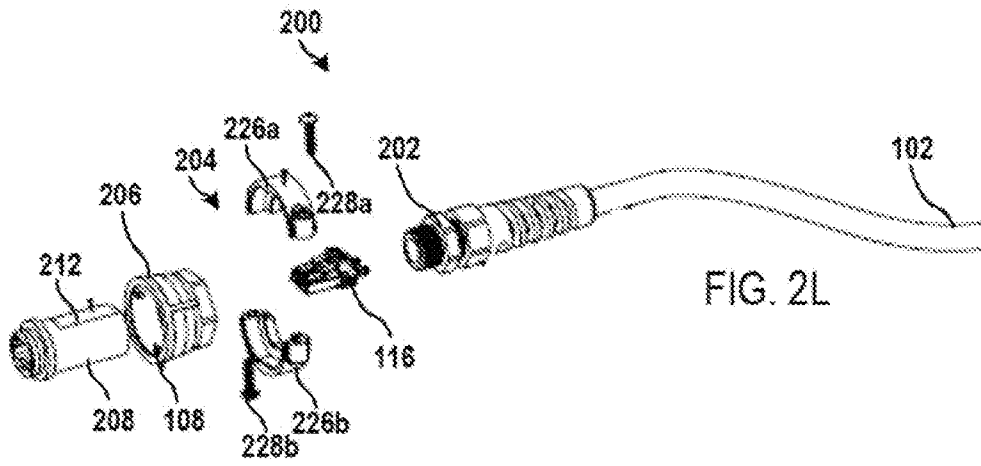

FIG. 2L

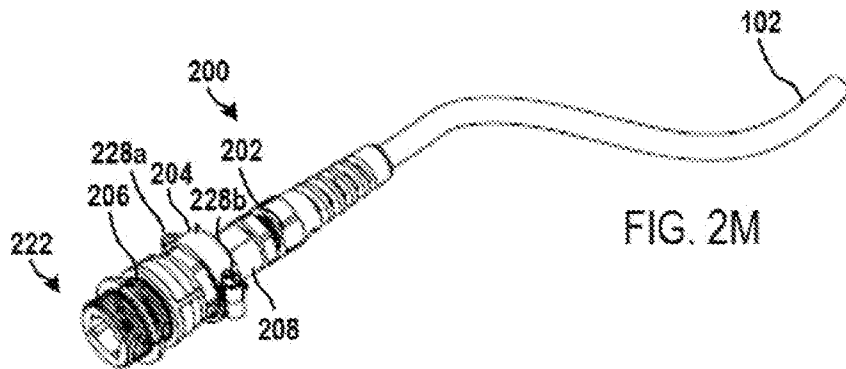
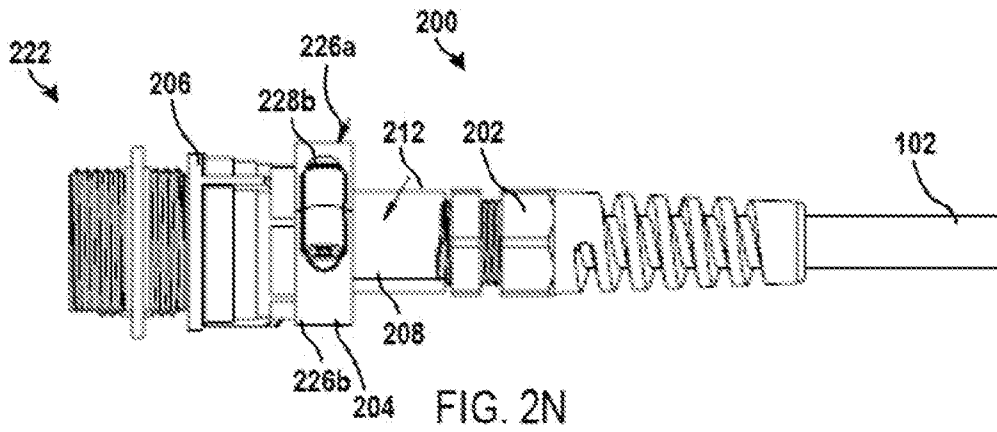
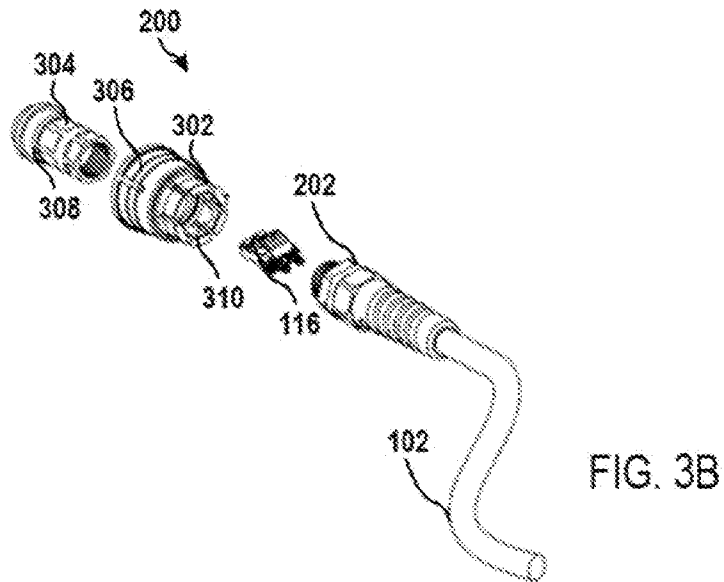
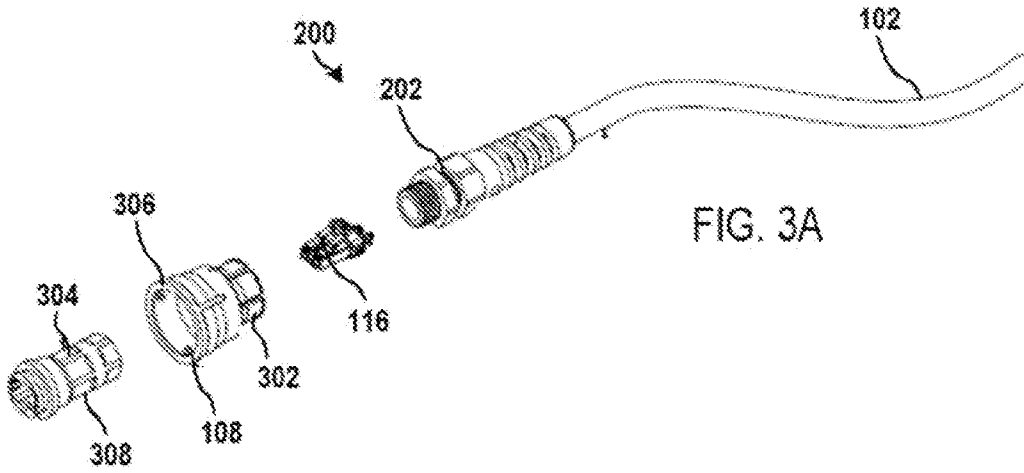

FIG. 2M

11/25



12/25



13/25

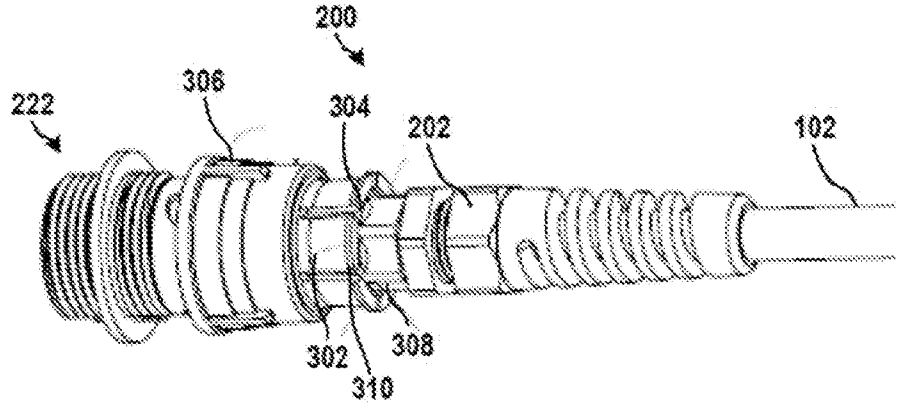

FIG. 3C

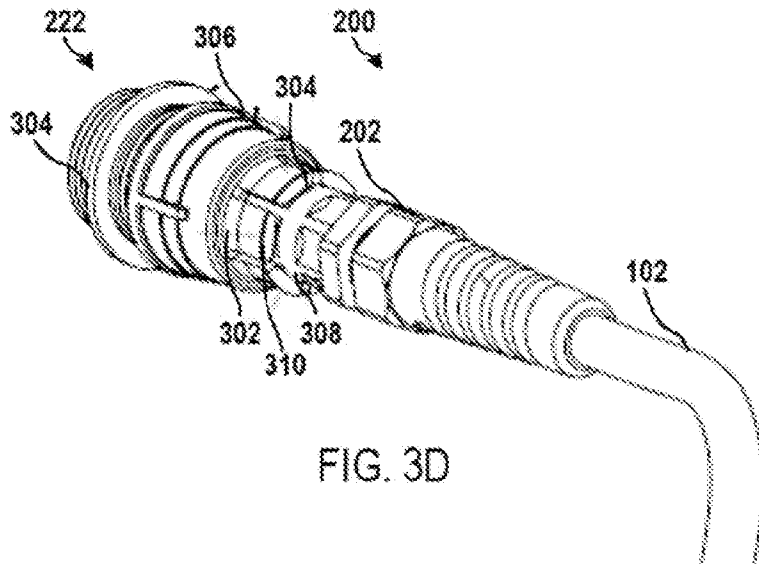
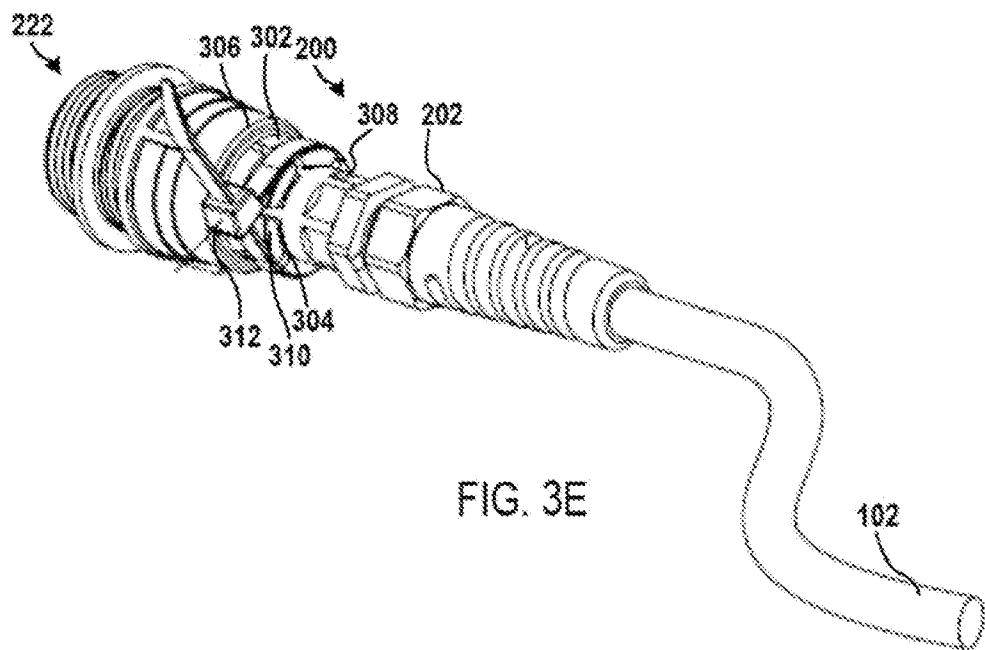
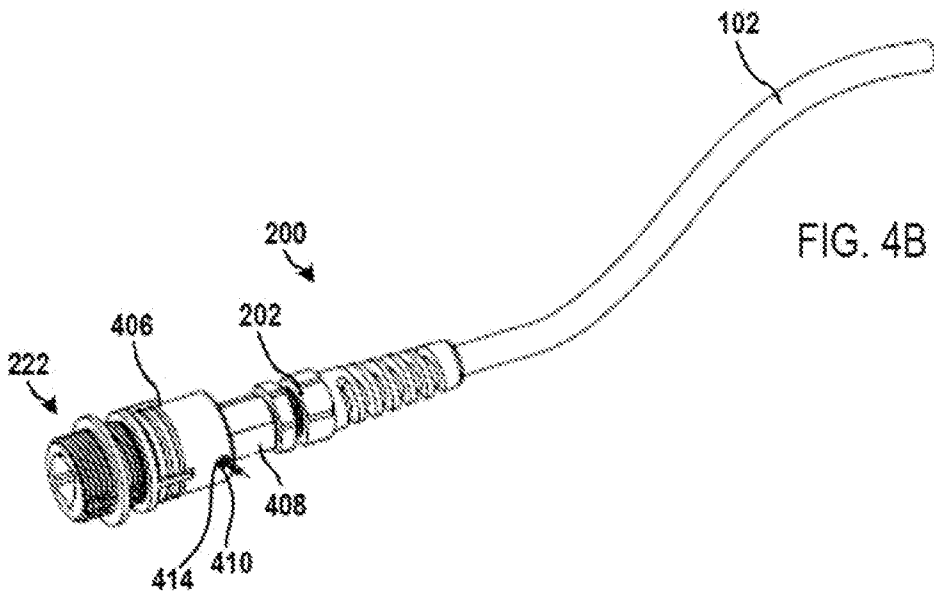
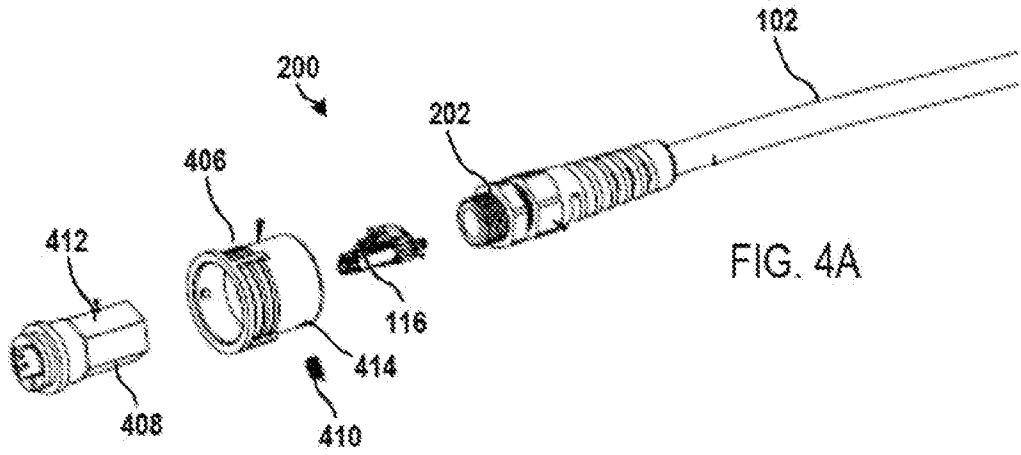

FIG. 3D





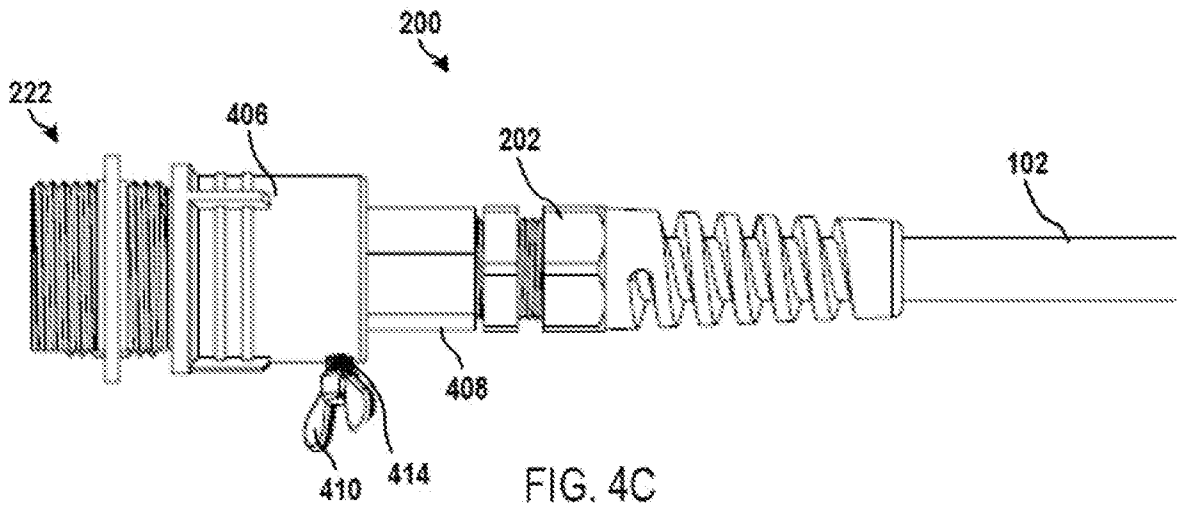
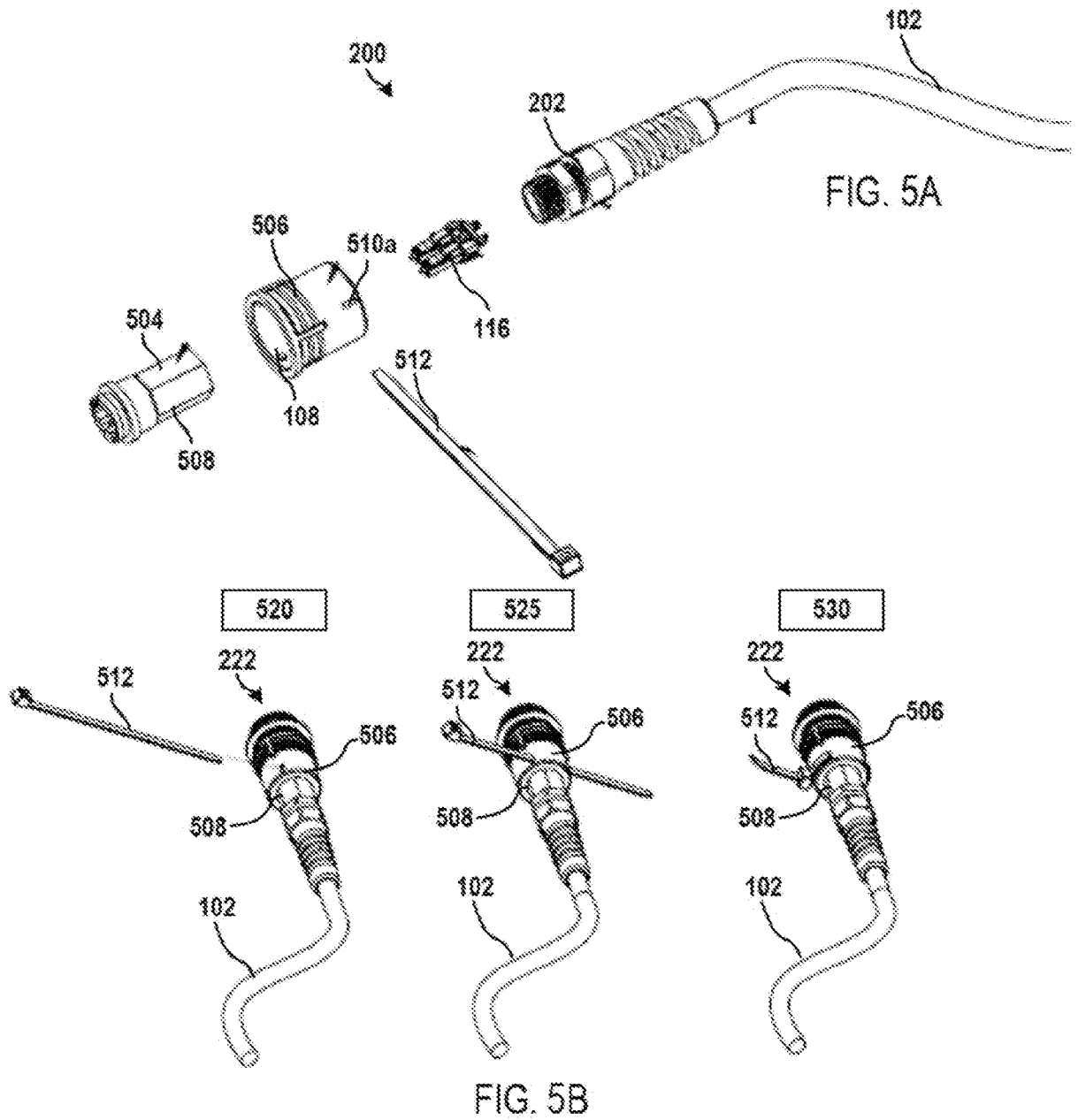

FIG. 4C



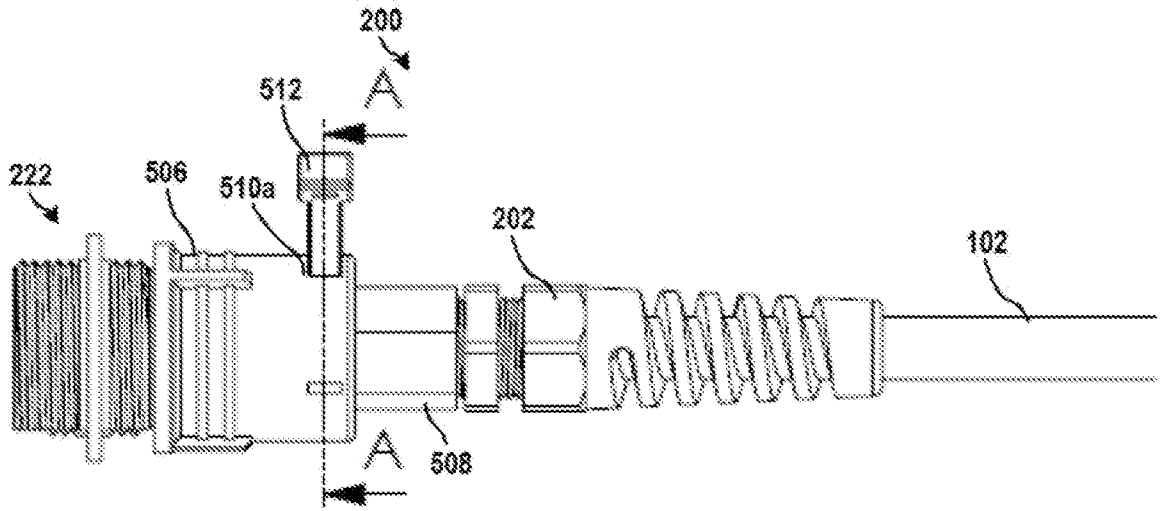

FIG. 5C

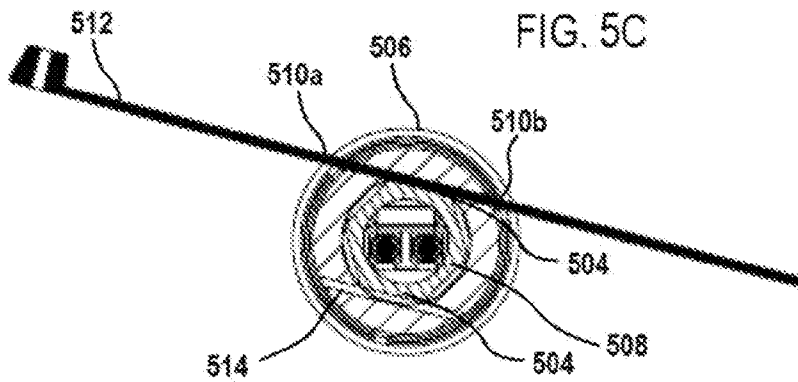

FIG. 5D

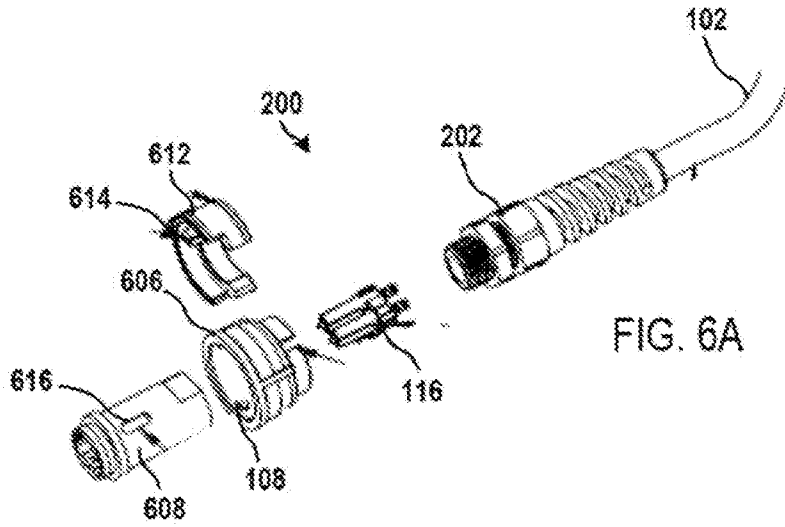

FIG. 6A

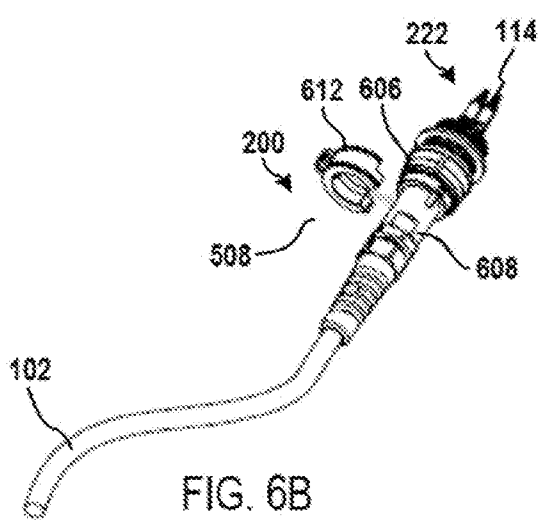

FIG. 6B

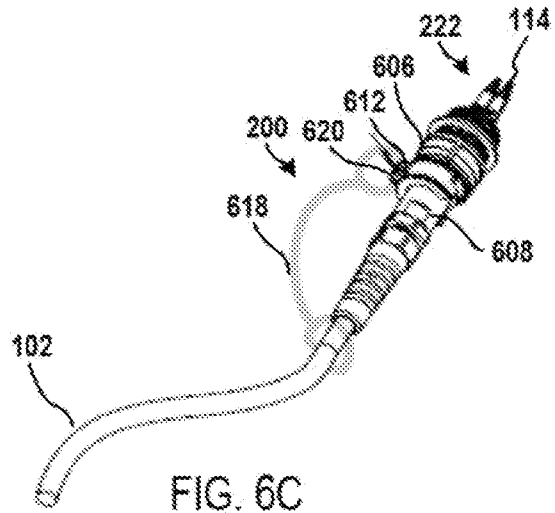

FIG. 6C

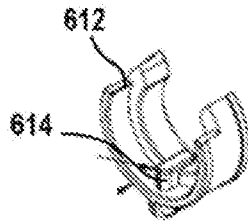

FIG. 6D

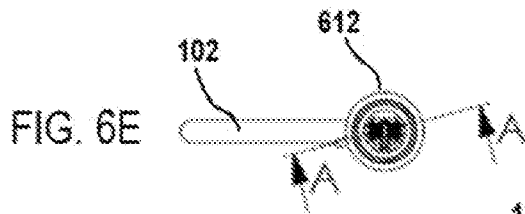

FIG. 6E

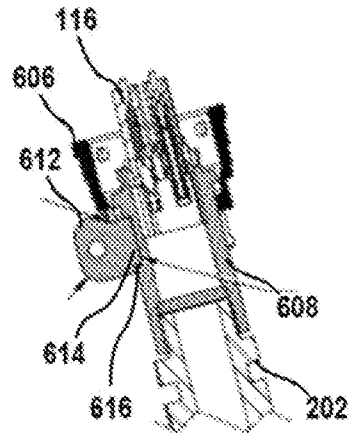

FIG. 6F

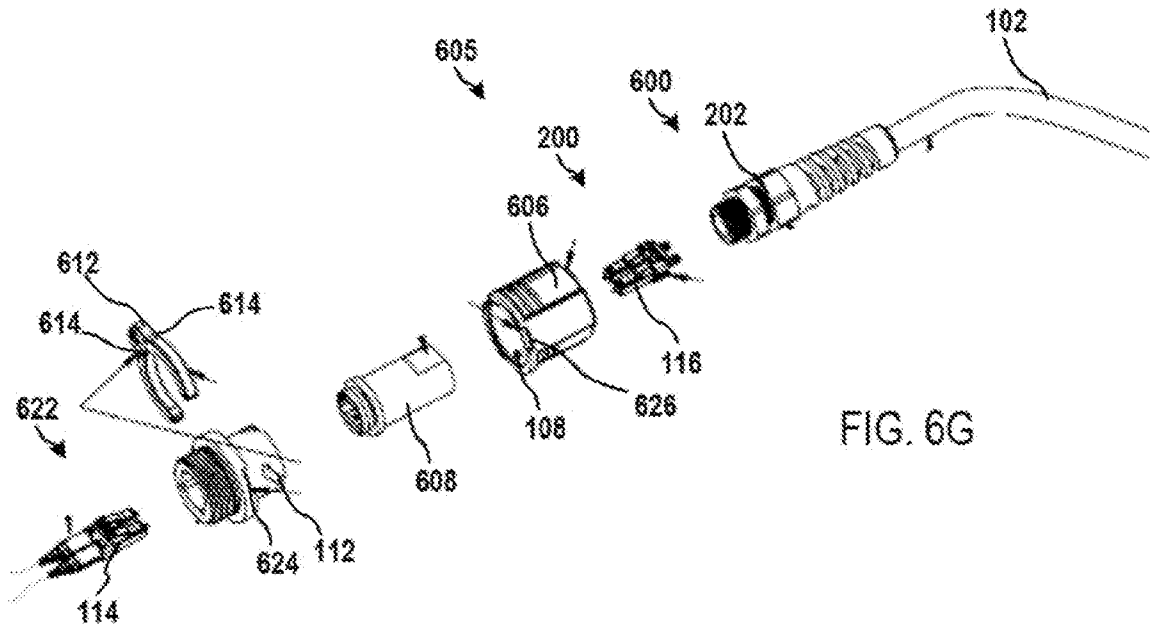

FIG. 6G

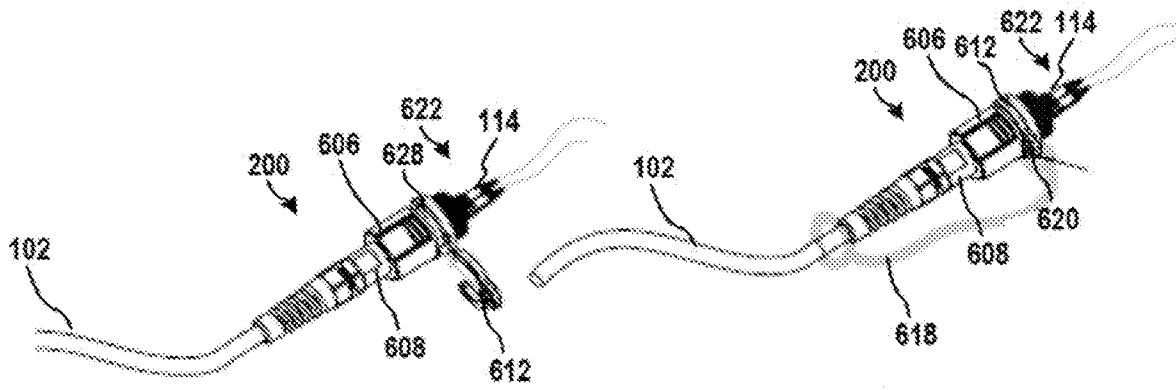

FIG. 6H

FIG. 6I

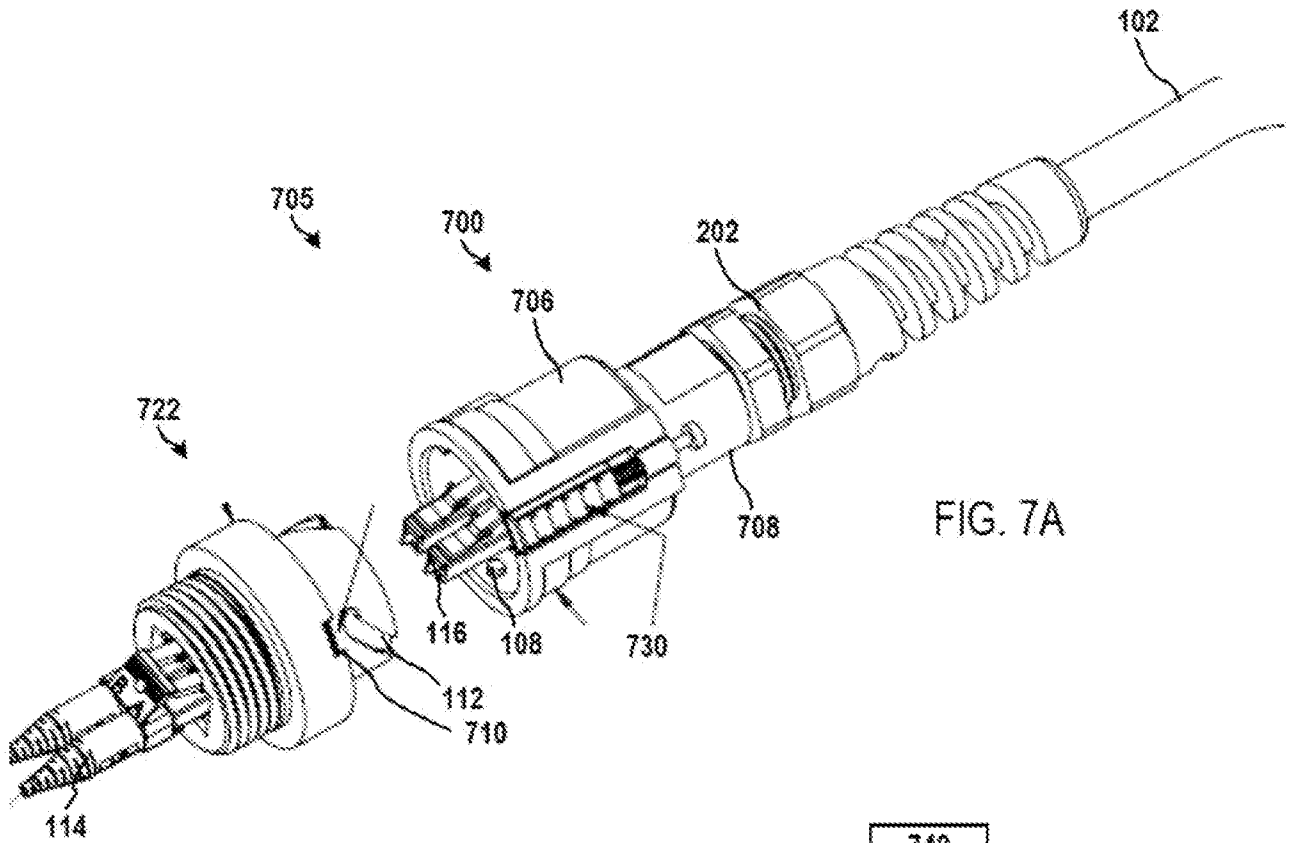

FIG. 7A

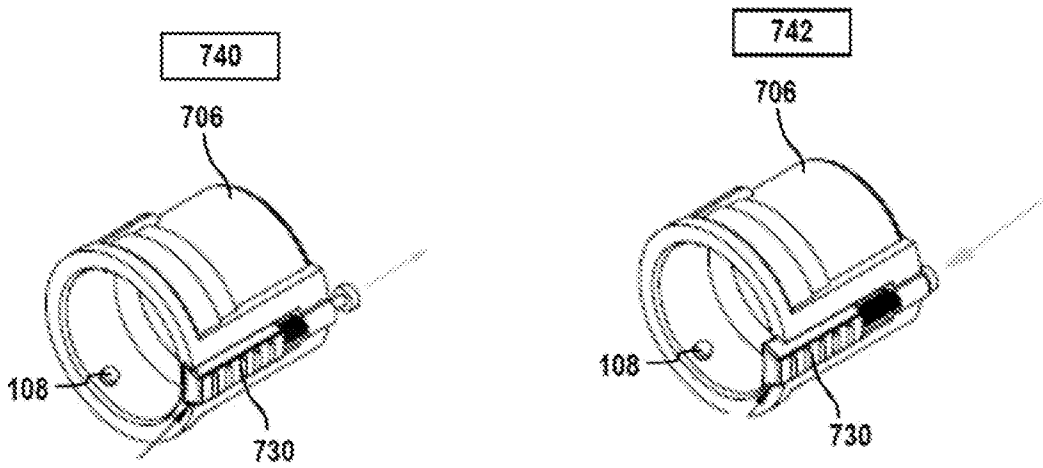

FIG. 7B

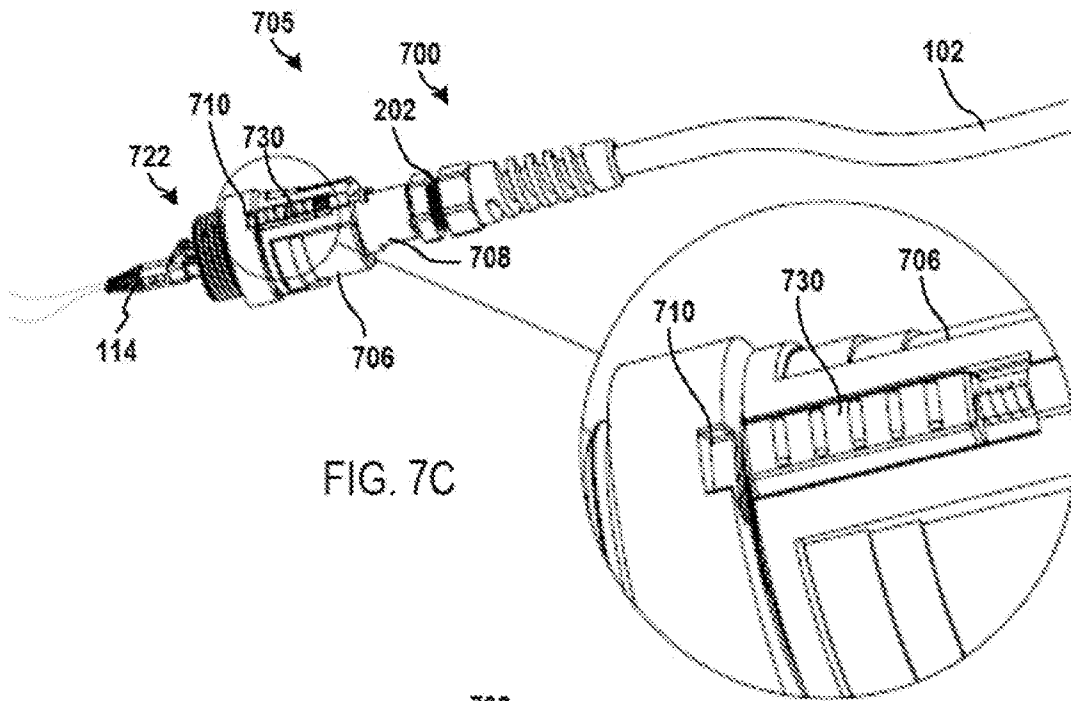

FIG. 7C

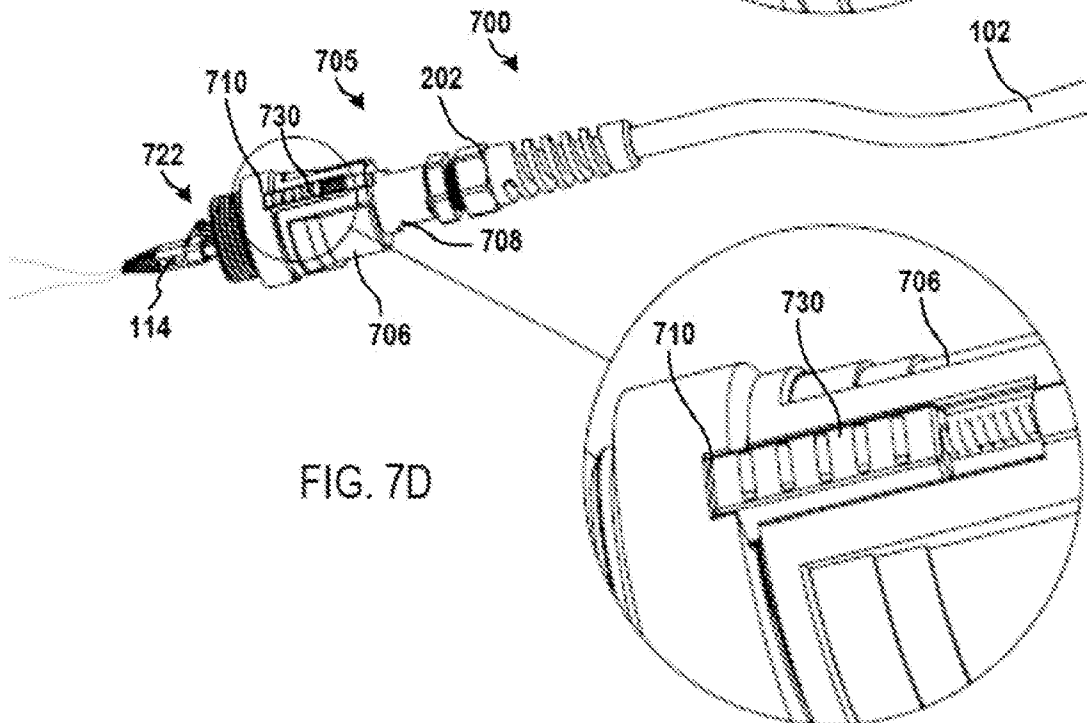
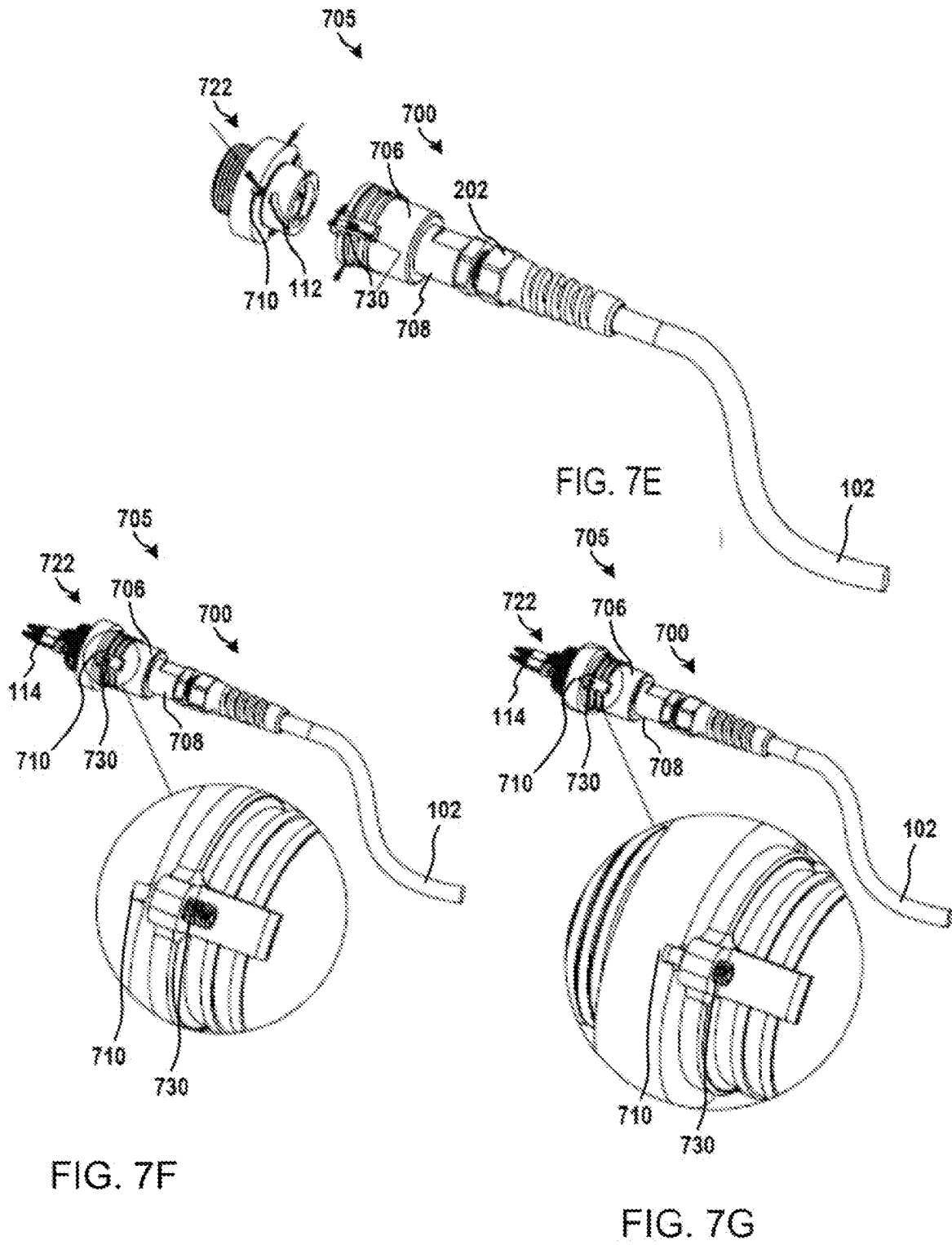
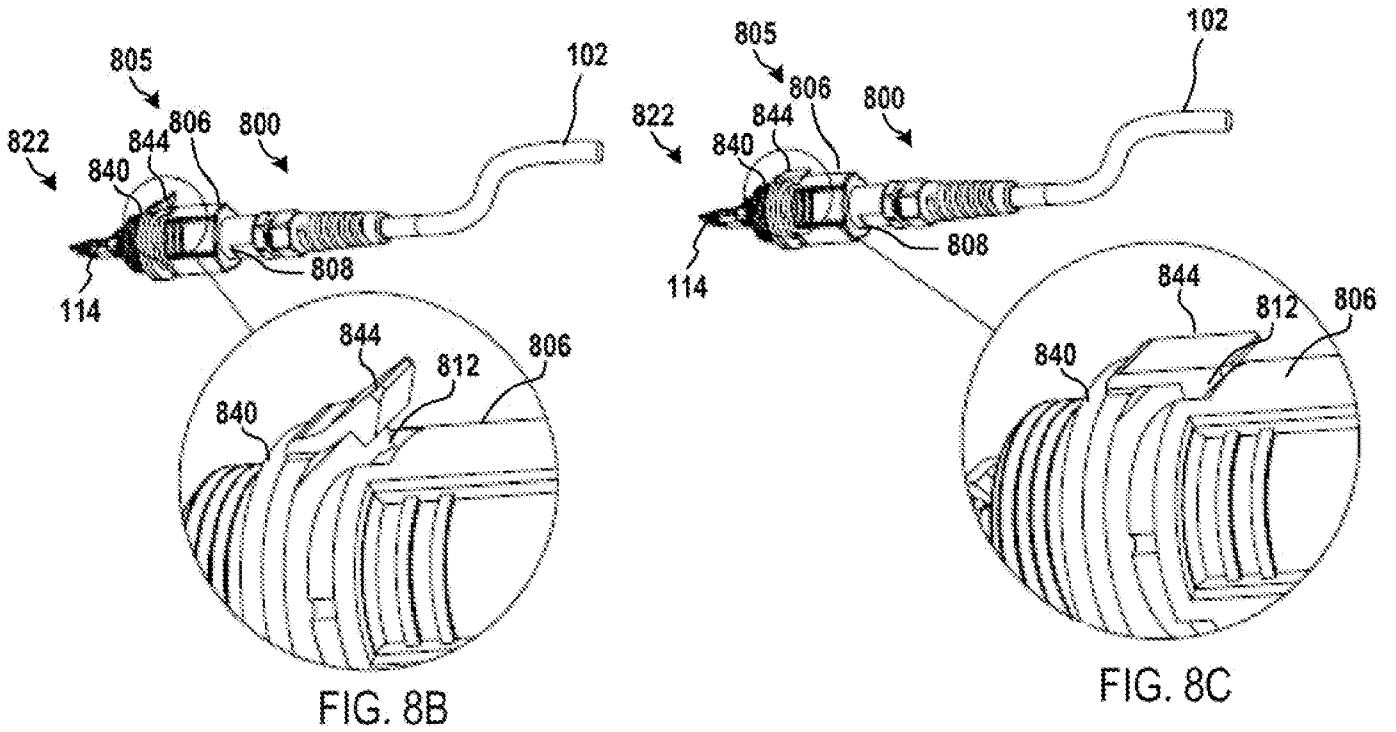
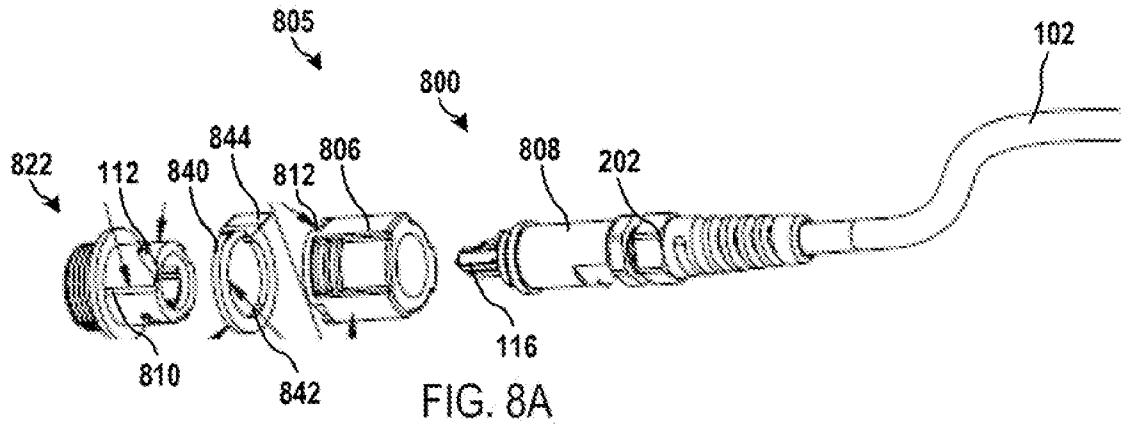

FIG. 7D





INTERNATIONAL SEARCH REPORT

International application No. **14/069095** **01.05.2015**

PCT/US2014/069095

**A. CLASSIFICATION OF SUBJECT MATTER**

IPC(8) - F16B 7/20 (2015.01)  
CPC - F16D 1/108 (2015.04)

According to International Patent Classification (IPC) or to both national classification and IPC

**B. FIELDS SEARCHED**

Minimum documentation searched (classification system followed by classification symbols)

IPC(8) - F16B 7/20; G02B 6/38; H01R 13/66 (2015.01)  
CPC - F16D 1/108; F16L 19/005; G02B 6/3891, 6/3897 (2015.04) (keyword delimited)

Documentation searched other than minimum documentation to the extent that such documents are included in the fields searched

USPC - 285/92; 385/56, 88; 403/362; 439/304, 328, 394, 412, 439, 620.03, 620.21, 672, 681, 700

Electronic data base consulted during the international search (name of data base and, where practicable, search terms used)

PatBase, Google Patent, Google

search terms used: coupling, couple, lock, non-rotatably, lockable connection, locking nut, coupling nut, fiber optic, set screw, wire tie, adapter, bayonet

**C. DOCUMENTS CONSIDERED TO BE RELEVANT**

Category*	Citation of document, with indication, where appropriate, of the relevant passages	Relevant to claim No.
X	US 5,882,044 A (SLOANE) 16 March 1999 (16.03.1999) entire document	1, 3, 5, 8, 9, 11, 19, 20
Y		2, 4, 6, 7, 10, 12-15, 17, 18, 21-33
Y	US 3,287,031 A (SIMMONS et al) 22 November 1966 (22.11.1966) entire document	2, 4
Y	US 6,062,739 A (BLAKE et al) 16 May 2000 (16.05.2000) entire document	6,7, 17, 18, 23, 24, 29, 30
Y	US 6,126,359 A (DITTRICH et al) 03 October 2000 (03.10.2000) entire document	10, 21, 27, 33
Y	US 5,083,819 A (BYNUM) 28 January 1992 (28.01.1992) entire document	12
Y	US 4,086,946 A (KEEN) 02 May 1978 (02.05.1978) entire document	13-15
Y	US 2007/0231064 A1 (CARNEVALI) 04 October 2007 (04.10.2007) entire document	15
Y	US 5,215,336 A (WORTHING) 01 June 1993 (01.06.1993) entire document	22-27
Y	DE 37 43 170 C1 (WEINHOLD) 18 May 1989 (18.05.1989) see machine translation	28-33
A	US 2006/0089049 A1 (SEDOR) 27 April 2006 (27.04.2006) entire document	1-41
A	US 4,648,671 A (TORBAN et al) 10 March 1987 (10.03.1987) entire document	1-41
A	US 2,448,548 A (PURDY) 07 September 1948 (07.09.1948) entire document	1-41

Further documents are listed in the continuation of Box C.

\* Special categories of cited documents:

"A" document defining the general state of the art which is not considered to be of particular relevance

"E" earlier application or patent but published on or after the international filing date

"L" document which may throw doubts on priority claim(s) or which is cited to establish the publication date of another citation or other special reason (as specified)

"O" document referring to an oral disclosure, use, exhibition or other means

"P" document published prior to the international filing date but later than the priority date claimed

"T" later document published after the international filing date or priority date and not in conflict with the application but cited to understand the principle or theory underlying the invention

"X" document of particular relevance; the claimed invention cannot be considered novel or cannot be considered to involve an inventive step when the document is taken alone

"Y" document of particular relevance; the claimed invention cannot be considered to involve an inventive step when the document is combined with one or more other such documents, such combination being obvious to a person skilled in the art

"&" document member of the same patent family

Date of the actual completion of the international search

20 April 2015

Date of mailing of the international search report

**01 MAY 2015**

Name and mailing address of the ISA/US

Mail Stop PCT, Attn: ISA/US, Commissioner for Patents  
P.O. Box 1450, Alexandria, Virginia 22313-1450  
Facsimile No. 571-273-3201

Authorized officer:

Blaine R. Copenheaver

PCT Helpdesk: 571-272-4300  
PCT OSP: 571-272-7774

## INTERNATIONAL SEARCH REPORT

014/069095 01.05.2015

International application No.

PCT/US2014/069095

**Box No. II Observations where certain claims were found unsearchable (Continuation of item 2 of first sheet)**

This international search report has not been established in respect of certain claims under Article 17(2)(a) for the following reasons:

1.  Claims Nos.:  
because they relate to subject matter not required to be searched by this Authority, namely:
  
2.  Claims Nos.:  
because they relate to parts of the international application that do not comply with the prescribed requirements to such an extent that no meaningful international search can be carried out, specifically:
  
3.  Claims Nos.:  
because they are dependent claims and are not drafted in accordance with the second and third sentences of Rule 6.4(a).

**Box No. III Observations where unity of invention is lacking (Continuation of item 3 of first sheet)**

This International Searching Authority found multiple inventions in this international application, as follows:

see continuation sheet attached

1.  As all required additional search fees were timely paid by the applicant, this international search report covers all searchable claims.
2.  As all searchable claims could be searched without effort justifying additional fees, this Authority did not invite payment of additional fees.
3.  As only some of the required additional search fees were timely paid by the applicant, this international search report covers only those claims for which fees were paid, specifically claims Nos.:
  
4.  No required additional search fees were timely paid by the applicant. Consequently, this international search report is restricted to the invention first mentioned in the claims; it is covered by claims Nos.:

**Remark on Protest**

- The additional search fees were accompanied by the applicant's protest and, where applicable, the payment of a protest fee.
- The additional search fees were accompanied by the applicant's protest but the applicable protest fee was not paid within the time limit specified in the invitation.
- No protest accompanied the payment of additional search fees.

This application contains the following inventions or groups of inventions which are not so linked as to form a single general inventive concept under PCT Rule 13.1. In order for all inventions to be examined, the appropriate additional examination fees must be paid.

Group I, claims 1-21 are drawn to a lockable connection component comprising a locking collar.

Group II, claims 11-33 are drawn to a lockable connection component comprising a clip component.

Group III, claims 11-21, 34-41 are drawn to a lockable connection component comprising a latch component.

The inventions listed as Groups I, II, and III do not relate to a single general inventive concept under PCT Rule 13.1 because, under PCT Rule 13.2, they lack the same or corresponding special technical features for the following reasons:

The special technical features of the Group I invention, a lockable connection component comprising a coupling nut having at least one locking collar interface, a locking collar having at least one coupling nut interface, the locking collar being configured to non-rotatably slide over the connector body and interface with the coupling nut such that the at least one coupling nut interface engages the at least one locking collar interface, thereby preventing the coupling nut from rotating and disconnecting from the complementary mating component, are not present in Groups II, III; the special technical features of the Group II invention, a lockable connection component comprising a coupling nut having at least one slot, and a clip component having at least one protrusion, the clip component being configured to engage the coupling nut such that the at least one protrusion extends through the at least one slot and engages the at least one external recess, thereby preventing the coupling nut from rotating and disconnecting from the complementary mating component, are not present in Groups I, III; and the special technical features of the Group III invention, a lockable connection component comprising a coupling nut having at least one groove, a latch component having at least one first protrusion arranged on an inside surface thereof and at least one second protrusion arranged on an external surface thereof, the latch component being arranged between the first connection component and a second connection component such that the at least one first protrusion is arranged within the at least one groove and the at least one second protrusion is arranged within at least one slot, thereby preventing the coupling nut from rotating and disconnecting from the second connection component, are not present in Groups I, II.

Unity exists between claims 1-21 (Group I), between claims 11-33 (Group II), or between claims 11-21, 34-41 (Group III). However unity does not exist between claims 1-10, 22-33, and 34-41 since there exists no common special technical feature between independent claims 1, (22, 28), and 34 (see PCT Examination Guidelines Chapter 10 at 10.37 Example 17).

Groups I, II, and III share the technical features of a lockable connection component comprising: a coupling nut configured to rotatably couple the lockable connection component to a complementary mating component, the coupling nut having at least one connector body interface element; and a connector body configured to be non-rotatably attached to the lockable connection component and arranged within a longitudinal bore of the coupling nut, the connector body having at least one coupling nut interface configured to be fixedly engaged by the at least one connector body interface element, thereby preventing the coupling nut from rotating and disconnecting from the complementary mating component.

However, these technical features do not represent a contribution over the prior art. Specifically, US 4,478,473 A to Frear teaches of a lockable connection component (Abstract) comprising: a coupling nut (300, Fig. 1) configured to rotatably couple the lockable connection component (200, Fig. 1; Col. 2, Lns. 63-67) to a complementary mating component (100, Fig. 2), the coupling nut (300, Figs. 1, 2) having at least one connector body interface element (350, Figs. 1-4); and a connector body (140, Figs. 1-4) configured to be non-rotatably attached to the lockable connection component (100, Fig. 2), and arranged within a longitudinal bore of the coupling nut (140 is within bore of 300, Fig. 1), the connector body having at least one coupling nut interface (outer surface of 140, Figs. 1-2) configured to be fixedly engaged by the at least one connector body interface element (350, Figs. 1-4), thereby preventing the coupling nut from rotating and disconnecting from the complementary mating component (Col. 3, Lns 7-16).

Groups II, and III share the technical features of a second connection component having a slot.  
However, these technical features do not represent a contribution over the prior art. Specifically, US 4,478,473 A to Frear teaches of a second connection component (370, Figs. 3-4) having a slot (U-shaped slot 376, Figs. 3-4).

Since none of the special technical features of the Groups I, II, and III inventions are found in more than one of the inventions, unity of invention is lacking.