

(No Model.)

G. E. ANDERSON.  
CLUTCH.

No. 512,933.

Patented Jan. 16, 1894.

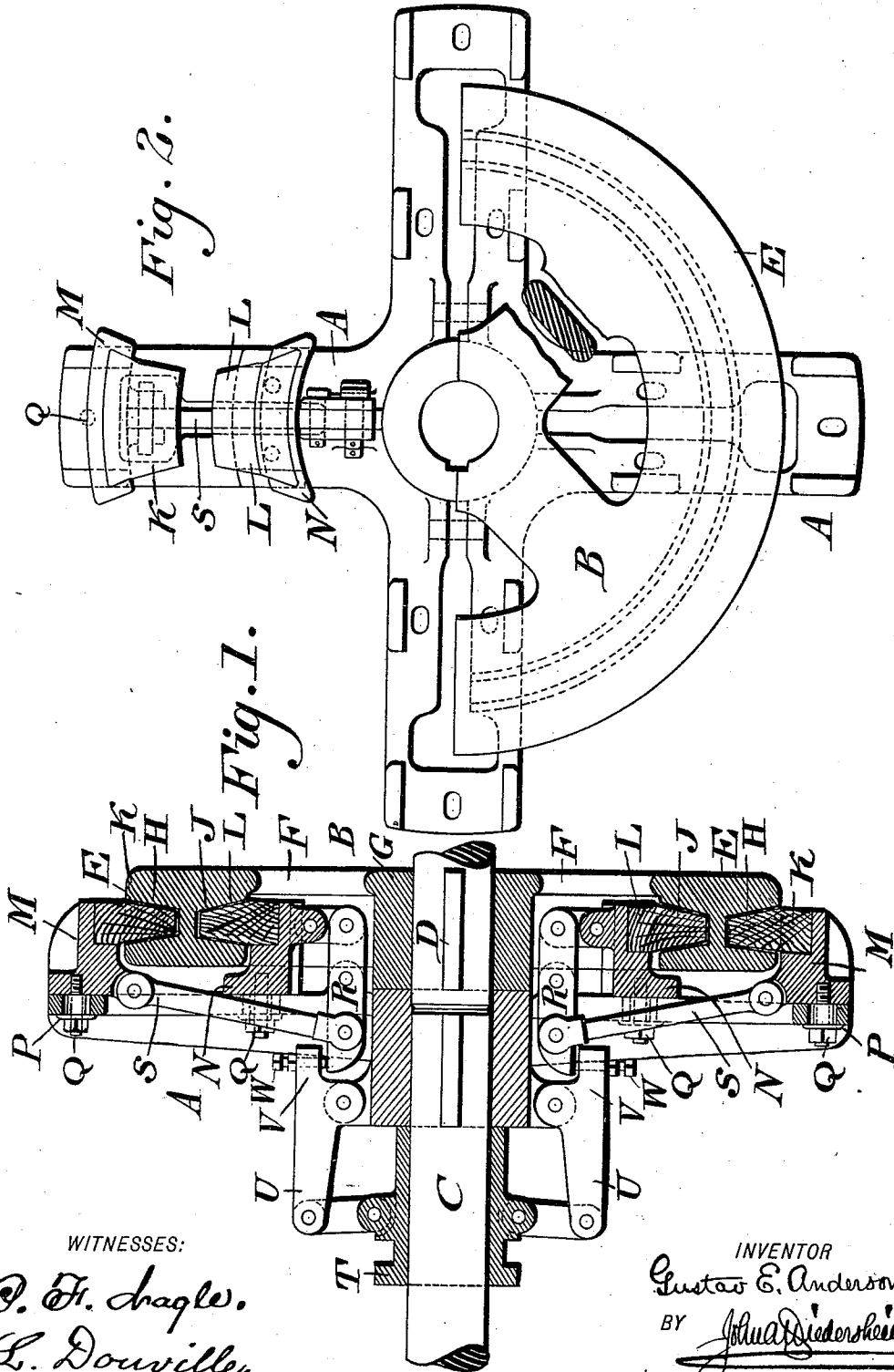

WITNESSES:  
*C. H. Ingle.*  
*L. Douville.*

INVENTOR  
*Gustav E. Anderson.*  
BY *John Diederichsen.*  
ATTORNEY.

# UNITED STATES PATENT OFFICE.

GUSTAV E. ANDERSON, OF PHILADELPHIA, PENNSYLVANIA, ASSIGNOR TO  
THE FAIRMOUNT MACHINE COMPANY, OF PENNSYLVANIA.

## CLUTCH.

SPECIFICATION forming part of Letters Patent No. 512,933, dated January 16, 1894.

Application filed May 31, 1893. Serial No. 476,087. (No model.)

*To all whom it may concern:*

Be it known that I, GUSTAV E. ANDERSON, a citizen of the United States, residing in the city and county of Philadelphia, State of Pennsylvania, have invented a new and useful Improvement in Clutches, which improvement is fully set forth in the following specification and accompanying drawings.

My invention consists of a clutch in which there is a double clutching action of one member on the other, the construction of parts being hereinafter set forth.

Figure 1 represents a diametrical section of a clutch embodying my invention. Fig. 2 represents a side elevation of one of the members thereof, certain portions being removed.

Similar letters of reference indicate corresponding parts in both the figures.

Referring to the drawings: A and B designate two clutch members, and C and D designate the shafts on which they are mounted.

E designates the rim of the member B, and F the supporting arms thereof, said arms radiating from the hub G. In the inner and outer peripheries of the rim are circular grooves or recesses H and J, in which are wedging blocks K and L, which are primarily free therein, and are connected respectively with radially sliding heads M and N, it being noticed that said blocks K and L point toward each other, and said heads are on the inner side of the member A, and guided in slots therein, and retained in position by means of plates or washers P, and nuts and bolts Q.

R designates compound levers which are mounted on the member A, near the hub thereof. One end of each of said levers R is pivotally connected with one of the slides N, and the other end has pivotally connected with it the link S, whose outer end is pivotally connected with one of the slides M.

T designates a sleeve on the shaft C, the same having pivotally connected with it the toggle levers U, the inner limb of each of which is mounted on the hub of the member A, and having on its inner end an extension V, which carries an adjusting bolt W, whose point is adapted to engage with the adjacent end of the compound lever R.

The operation is as follows: When the sleeve

is moved, say to the left, the toggle levers are so operated that the bolts W are advanced against the compound levers R. This draws in the links S, thus pressing the blocks K into the recess H, and at the same time forces up the blocks L into the recess J, thus causing said blocks to tighten against the walls of said recesses, and consequently against the rim E, thus clutching the two members A and B. When the sleeve is moved to the right, or from the left to the position shown in the drawings, the compound levers are relieved of their wedging action on the rim E, and thus the two members are disconnected or unclutched. The entire movement of the sleeve T in either direction is small, the movement to lock the clutch being only from the position shown in Fig. 1 to the left, until the links connecting it with the levers U are in perpendicular position, and the movement to unlock the clutch being simply the reverse. In said figure the distance between the wedging blocks and the walls of the grooves in the rim are somewhat exaggerated, so as to show them apart, while in actual practice the distances apart of said blocks and rim are comparatively small and appear almost in contact.

Having thus described my invention, what I claim as new, and desire to secure by Letters Patent, is—

1. A clutch consisting of two members, one of which has circumferential recesses on the outer and inner faces of its rim, the other member having radially-sliding heads provided with wedging blocks which move in said recesses, a sleeve having a toggle lever pivoted to it and to the last described clutch member, and a lever with links connected to said sliding heads, said parts being combined substantially as described.

2. A clutch having a member with recesses in the outer and inner faces of its rim, a member having radial slots therein, sliding heads with connecting bolts movable in said slots, and wedging blocks connected with said heads, a sleeve with toggle lever secured thereto and to said second described member, a compound lever pivoted to said second member and having links connecting it to said sliding heads, and an adjusting screw in said

toggle lever bearing on said compound lever, said parts being combined substantially as described.

3. A clutch member having a compound lever connected at one end with a wedging block, and a link pivoted to the other end of said lever, and connected with another wedging block, said member carrying a lever which is connected with an operating sleeve, in combination with the opposite clutch member having a doubly-recessed rim which receives said blocks in opposite directions, substantially as described.

4. A clutch having a member with a recess

in its rim, and a second member provided with a radially-sliding head with a wedging block movable in said recess, a sleeve with a toggle lever pivoted thereto and to said second member, and a lever pivoted to said second member and connected by a link with said head, said toggle lever bearing on one end of said pivoted lever, said parts being combined substantially as described.

GUSTAV E. ANDERSON.

Witnesses:

JOHN A. WIEDERSHEIM,  
WM. C. WIEDERSHEIM.