



- (51) **International Patent Classification:**  
*B65D 33/25* (2006.01)
- (21) **International Application Number:**  
PCT/GB2010/050238
- (22) **International Filing Date:**  
12 February 2010 (12.02.2010)
- (25) **Filing Language:** English
- (26) **Publication Language:** English
- (30) **Priority Data:**  
0902528.9 16 February 2009 (16.02.2009) GB  
0908586.1 19 May 2009 (19.05.2009) GB
- (71) **Applicant (for all designated States except US):** ILLINOIS TOOL WORKS INC. [US/US]; 3600 West Lake Avenue, Glenview, Illinois 60026 (US).
- (72) **Inventor; and**
- (75) **Inventor/Applicant (for US only):** LEIGHTON, Murray, Edward, Bruce [GB/GB]; 12 Bachelor Drive, Harrogate, North Yorkshire HG1 3EH (GB).
- (74) **Agent:** ACKROYD, Robert; W P Thompson & Co, 55 Drury Lane, London WC2B 5SQ (GB).

- (81) **Designated States (unless otherwise indicated, for every kind of national protection available):** AE, AG, AL, AM, AO, AT, AU, AZ, BA, BB, BG, BH, BR, BW, BY, BZ, CA, CH, CL, CN, CO, CR, CU, CZ, DE, DK, DM, DO, DZ, EC, EE, EG, ES, FI, GB, GD, GE, GH, GM, GT, HN, HR, HU, ID, IL, IN, IS, JP, KE, KG, KM, KN, KP, KR, KZ, LA, LC, LK, LR, LS, LT, LU, LY, MA, MD, ME, MG, MK, MN, MW, MX, MY, MZ, NA, NG, NI, NO, NZ, OM, PE, PG, PH, PL, PT, RO, RS, RU, SC, SD, SE, SG, SK, SL, SM, ST, SV, SY, TH, TJ, TM, TN, TR, TT, TZ, UA, UG, US, UZ, VC, VN, ZA, ZM, ZW.
- (84) **Designated States (unless otherwise indicated, for every kind of regional protection available):** ARIPO (BW, GH, GM, KE, LS, MW, MZ, NA, SD, SL, SZ, TZ, UG, ZM, ZW), Eurasian (AM, AZ, BY, KG, KZ, MD, RU, TJ, TM), European (AT, BE, BG, CH, CY, CZ, DE, DK, EE, ES, FI, FR, GB, GR, HR, HU, IE, IS, IT, LT, LU, LV, MC, MK, MT, NL, NO, PL, PT, RO, SE, SI, SK, SM, TR), OAPI (BF, BJ, CF, CG, CI, CM, GA, GN, GQ, GW, ML, MR, NE, SN, TD, TG).

**Published:**  
— with international search report (Art. 21(3))

(54) **Title:** ZIPPER FASTENERS, SLIDERS THEREFOR, METHODS AND APPARATUS FOR APPLYING ZIPPER FASTENERS TO SUBSTRATES

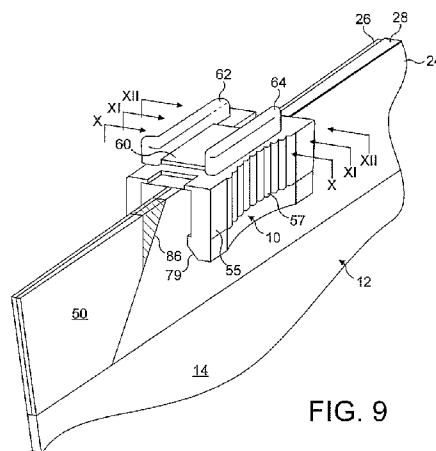

FIG. 9

(57) **Abstract:** The slider (10) is shaped to have an internal cavity (80) above its profile-separating plough (70). The cavity (80) receives a portion (86) of an end stomp (50) of the zipper (24) so that, when the slider is at the limit of its zipper-closing movement, no gap is left between the slider (10) and the end stomp (50). To achieve this, the end surface of the end stomp is formed obliquely to the length of the zipper (24) and provides a triangular portion (86) of the stomp which is received in the cavity (80). Also disclosed are methods of forming the end stomp, apparatus therefor and various different shapes of end stomp achieving the same objective.

WO 2010/092404 A1

**ZIPPER FASTENERS, SLIDERS THEREFOR, METHODS AND APPARATUS FOR APPLYING ZIPPER FASTENERS TO SUBSTRATES**

The present invention relates to sliders for zipper fasteners which comprise a pair of interengagable profile strips. The profile strips are brought into and out of engagement with each other by movement of the slider along the zipper, the slider being shaped respectively to press the profile strips into engagement with each other and to separate them upon movement in first and second, opposite directions. The invention also relates to zipper fasteners and to methods and apparatus for applying zipper fasteners to substrates.

Sliders as referred to are sometimes known as "clips".

Throughout the description and the claims of this specification, the end of the slider which leads upon movement in the zipper-closing direction is referred to as the "leading end"; the other end is referred to as the "trailing end". Further, throughout the specification and claims the fasteners disclosed are described in an orientation in which the reclosable packages with which they are used are orientated with their open edges uppermost. Terms such as "top", "downwardly" etc. are used accordingly but without any limitation as to orientation.

Zipper fasteners as just described are used to provide a resealable closure to a wide variety of containers, for example bags of flexible sheet plastics material, used for food and a wide variety of other products.

In use of such zippers, in such bags and otherwise, the ends of the profiles are often sealed to each other to

form a conjoined end portion which is known as an end "stomp". This may be formed, for example, by the application of heat and pressure, whereupon the profiles become fused together. The formation of end stomps prevents the slider from leaving the profiles at the ends of its travel therealong.

Examples of known end stomps can be found in EP-A-1407681, JP-A-2007-223651, US-A-5664299, US-A-6088887, US-B-6287001, US-B-6568046, US-A-2004/0045134, WO-A-98/45180, WO-A-00/763410, WO-A-00/76350 and WO-A-03/080457.

The presence of end stomps however leads to a disadvantage: this is that the profiles of the zipper are not brought into engagement with each other over a portion of their lengths adjacent at least one of the end stomps. This results in a gap, through which ambient air can enter the container to the detriment of its contents and which is also perceived as unsightly.

The present invention aims to alleviate or overcome this disadvantage.

The present invention provides a zipper fastener comprising a pair of interengagable profiles, the zipper profiles being joined to each other over a portion of their lengths adjacent at least one of their ends to form a conjoined end portion which extends over at least a portion of the width of the fastener and is shaped at its edge distant from the end of the zipper to extend a greater distance towards the longitudinal mid-point of the zipper adjacent one longitudinal edge of the said portion of the fastener than adjacent the other.

Such a fastener can interact more effectively with a slider or clip mounted thereon.

Preferably, the edge of the conjoined end portion of the zipper profiles distant from the end of the zipper extends obliquely across said portion of the fastener.

Conveniently, the edge of the conjoined end portion is rectilinear.

Preferably, the edge extends at an angle to the longitudinal zipper edges which is less than 90 degrees. More preferably, the angle is less than 60 degrees. Advantageously, the angle is between 30 degrees and 60 degrees.

The edge may however extend curvilinearly across the zipper, the curvilinear edge being convex or concave towards the other conjoined portion.

Other curved shapes are also possible within the scope of the invention, for example the curvilinear edge may follow an ogee curve, having convex and concave portions.

Another possibility is that the edge has a stepped shape.

The stepped shape advantageously comprises at least two steps, which may be formed by portions extending perpendicularly to the longitudinal edges of the profiles and at least one portion therebetween extending substantially parallel thereto. Other stepped shapes, in which the said portions are oblique to the zipper edges, are also possible.

Although only one end stomp of the zipper may be shaped as aforesaid, preferably the edges of both conjoined end portions extend a greater distance towards the midpoint of the zipper adjacent one longitudinal edge of the zipper than the other.

So that zippers as referred to hereinbefore which are of a length appropriate for the package with which they are to be used, or of which they form a part, can be severed from a continuous length of zipper material, the present invention also provides a zipper fastener comprising first and second profiles which are releasably engagable and re-engagable with each other, each profile comprising a first longitudinally extending portion having formations for engagement with the first portion of the other profile and, laterally thereof, a second, flange portion for attachment of the respective profile to a substrate, the first portion lying closer to a first lateral edge of the zipper and the second portions lying closer to a second lateral edge of the zipper, wherein the profiles have conjoined portions at spaced intervals along their lengths, the conjoined portions extending over at least a portion of the width of at least the first portion and being arranged in pairs at a first interval between the conjoined portions of each pair and a second interval between the pairs, at least one of the conjoined portions of each pair being shaped such that it extends a greater distance towards the other conjoined portion of the pair adjacent the first longitudinal edge of the said conjoined portion than adjacent the other.

The first interval will normally be the length appropriate for the package with which the zipper is to be used, the second interval being a convenient spacing

between such lengths. Thus, the first interval is preferably greater than the second interval.

Advantageously, the zipper has portions of reduced width located between the pairs of conjoined portions. These reduced-width portions provide convenient places for the continuous zipper to be severed into individual lengths appropriate for a package with which they are to be used.

Conveniently, the portions of reduced width are formed by removal of material from the second portions of the zipper profiles, the removed portions preferably being substantially semi-circular.

Again, it is preferred that both conjoined portions of each pair thereof are shaped such that they extend a greater distance towards the other conjoined portion of the pair adjacent the first longitudinal edge of the said conjoined portion than adjacent the other.

The conjoined portion(s) are preferably shaped as referred to hereinbefore.

According to the invention, the conjoined portions may extend over all or part of the width of the zipper profiles. When the profiles comprise shaped, interengaging portions and, laterally thereof, flange portions, the conjoined portions may extend over some or all of the width of the shaped portions and, optionally, some or all of the flange portions. It is therefore within the scope of the invention for the flange portions not to be conjoined, whilst some or, preferably, all of the interengaging portions are conjoined. When employed with a slider of the

invention, some or all of the conjoined portion may locate in the slider cavity.

Zippers according to the invention, formed as continuous lengths or otherwise, may be used in conjunction with a wide range of packaging machinery, which may comprise apparatus for attaching zipper fastener comprising first and second interengagable profiles to a substrate, the apparatus including means for feeding the fastener to the substrate, means for attaching it to the substrate and means for forming pairs of conjoined portions of the profiles at intervals along the length of the fastener, the means for forming the conjoined portions being such that at least one of the conjoined portions of each pair is shaped at its edge facing the other conjoined portion to extend a greater distance towards the other portion at a first longitudinal edge of the zipper than at the second longitudinal edge thereof.

Advantageously, the means for forming the conjoined portions are such that both conjoined portions of each pair are shaped at their edges facing the other conjoined portion to extend a greater distance towards the other portion at a first longitudinal edge of the zipper than at the second longitudinal edge thereof.

Conveniently, the apparatus includes means for forming reduced-width portions of the zipper between adjacent pairs of conjoined portions.

Preferably, the means for forming the conjoined portions comprise first and second members shaped to form the conjoined end portions and to crush the zipper therebetween.

Conveniently, the means for forming the reduced-width portions comprise die and punch members, between which the zipper is arranged to pass.

In another convenient arrangement, the means for forming the reduced-width portion comprise first and second rotary cutters, between which the zipper is arranged to pass.

Advantageously, when both are provided, the means for forming the conjoined end portions and the means for forming the reduced-width portion are arranged to move as a unit longitudinally of the zipper. This is particularly useful in machinery in which the zipper is fed continuously.

Apparatus according to the invention may include means for severing the zipper fastener into individual lengths at locations between adjacent pairs of conjoined portions, preferably at the reduced-width portions.

The Apparatus may be of the "TD" or "cross-web" type, arranged to attach the zipper lengths to a substrate transversely to the direction of movement of the substrate.

In other instances, the apparatus is of the "MD" or "in line" type, arranged to attach the zipper in a continuous length in the direction of movement of the substrate.

In all forms of the invention, there may be means for mounting sliders on the fastener between the conjoined portions of each pair thereof.



The apparatus may be a form-fill-seal apparatus, of the vertically- or horizontally-operating type.

Alternatively, the apparatus is of the kind which makes unfilled packages, for subsequent filling.

The apparatus incorporating the invention may be a so-called "reel-to-reel" apparatus, in which lengths of zipper fastener to a continuous elongate substrate at spaced intervals therealong and transversely to the substrate. The substrate is then stored and later used as the feedstock of a machine for forming and, if desired, filling packages.

The present invention further provides a slider for mounting on a pair of interengagable profiles of a zipper fastener, the slider comprising a body having a longitudinal throughpassage for receiving the profiles; and means for mounting the slider body on the profiles for longitudinal sliding movement therealong;

the throughpassage being open at the bottom to allow the zipper profiles to pass therethrough for mounting of the slider thereon and being shaped to bring the profiles of a zipper on which the slider is mounted into engagement with each other upon movement of the slider therealong in a first direction; and

the body having a plough portion located in the throughpassage and shaped to separate the said profiles from engagement with each other upon movement therealong in a second, opposite direction;

wherein the throughpassage is shaped to define a cavity adjacent the leading end to receive a conjoined end

portion of the profiles of a said zipper fastener when the slider is mounted thereon.

Preferably, the cavity is located above the plough portion.

Conveniently, the body is shaped to define a roof portion which closes the top of the cavity.

Advantageously, the plough portion is formed at the lower end of a dependent support member which extends downwardly into the throughpassage.

Preferably, the plough portion is formed to extend from the support member in the direction towards the leading end of the throughpassage.

The present invention also provides a zipper fastener comprising a pair of interengagable profiles and a slider according to the invention mounted thereon for longitudinal sliding movement therealong, the zipper profiles being joined to each other over a portion of their lengths adjacent at least one of their ends to form a conjoined end portion at least a portion of which is receivable in the cavity in the throughpassage at the limit of the movement of the slider along the profiles in the first direction.

Preferably, the conjoined end portion of the zipper profiles is shaped at its end adjacent the slider to extend a greater distance towards the mid-point of the zipper at the upper edge of the profiles than at the lower edge.

Conveniently, the end of the conjoined end portion of the zipper profiles adjacent the slider extends obliquely across the width of the zipper.

Preferably, the end of the conjoined end portion is rectilinear.

Further, the present invention provides a zipper fastener comprising a pair of interengagable profiles, the zipper profiles being joined to each other over a portion of their lengths adjacent at least one of their ends to form a conjoined end portion which is shaped at its end distant from the end of the zipper to extend a greater distance towards the mid-point of the zipper at one edge of the fastener than the other.

Preferably, the end of the conjoined end portion of the zipper profiles distant from the end of the zipper extends obliquely across the zipper.

Advantageously, the end of the conjoined end portion is rectilinear

The invention also provides a sealing bar for use in production of the zipper according to the invention, the sealing bar having at least one raised end portion which is shaped to join the zipper profiles to each other over a portion of their lengths adjacent at least one of their ends to form a conjoined end portion which is shaped at its end distant from the end of the zipper to extend a greater distance towards the mid-point of the zipper at one edge of the fastener than the other.

Preferably, the raised end portion is defined by a step which extends obliquely across the sealing bar from one longitudinal edge to the other.

Conveniently, the step extends rectilinearly.

Further, the present invention provides an elongate web of flexible plastics material having first and second parallel longitudinal side edges and, spaced at regular intervals therealong lengths of zipper according to the invention, each being positioned mid-way between and extending transversely to the side edges of the web and having a length which is approximately one-half of the width of the web; and also a method making reclosable packages in which such a web is formed into a tube, the tube is flattened and sealed transversely at intervals such that a length of zipper is located between and adjacent to successive seals, the tube is severed into individual packages and, before or after severing, the zipper lengths are secured to the confronting surface of the web when formed into a tube.

The invention further provides an elongate web of flexible plastics material having first and second parallel longitudinal side edges and, spaced at regular intervals therealong lengths of zipper according to the invention, each being positioned mid-way between and extending transversely to the side edges of the web and having a length which is approximately one-half of the width of the web.

Further, the invention provides a method of making reclosable packages in which such a web is formed into a tube, the tube is flattened and sealed transversely at

intervals such that a length of zipper is located between and adjacent to successive seals, the tube is severed into individual packages and, before or after severing, the zipper lengths are secured to the confronting surface of the web when formed into a tube.

Embodiments of the invention will now be described by way of example with reference to the drawings hereof, in which:

Figure 1 is a somewhat schematic perspective view of a vertical form-fill-seal (VFFS) machine, in which zippers are applied to a packaging film in directions perpendicular to the direction of movement of the film;

Figure 2 is a somewhat schematic perspective view of a vertical form-fill-seal (VFFS) machine, in which zippers are applied to a packaging film in directions parallel to the direction of movement of the film;

Figure 3 shows a part of figure 3 on an enlarged scale;

Figure 4 is a section on the line IV - IV shown on figure 3;

Figure 5 is somewhat schematic perspective view of a horizontal form-fill-seal machine in which a zipper strip is attached to a thermoplastic sheet material perpendicularly to the direction of movement of the film;

Figure 6 is a somewhat schematic side view a horizontal form-fill-seal machine to which zipper is fed

longitudinally in the direction of movement of a thermoplastic film which is also fed to the machine;

Figure 7 is an end view of the machine shown in figure 6;

Figure 8 shows schematically a so-called reel-to-reel apparatus for making a roll of pre-zippered film;

Figure 9 is a perspective view of a part of a reclosable package of plastics material which is openable and closable by a zipper fastener;

Figure 10 is a sectional view in the plane X - X shown in figure 9 and looking from the leading end in the direction which is left-to-right in figure 9;

Figure 11 is a sectional view in the plane XI - XI shown in figure 9 and looking in the same direction as in figure 10;

Figure 12 is a sectional view in the plane XII - XII shown in figure 9, but looking from the trailing end in the opposite direction to the views of figures 10 and 11;

Figure 13 is a perspective view of the slider shown removed from the package of figure 9;

Figure 14 corresponds to figure 13 but with a portion of the slider shown broken-away;

Figure 15 shows in perspective view the broken-away slider of figure 14 mounted on one part of the zipper fastener shown in figure 9;

Figure 16 is a perspective view of the slider shown in figure 13, viewed from below;

Figure 17 is a sectional view in the plane XVII - XVII shown in figure 13 and looking in the direction which is left-to-right in figure 13;

Figure 18 is a sectional view in the plane XVIII - XVIII shown in figure 13 and looking in the same direction as figure 17;

Figure 19 is a sectional view in the plane XIX - XIX shown in figure 13, but looking in the opposite direction to the views of figures 17 and 18;

Figure 20 is a plan view of the slider as shown in figure 9;

Figure 21 is a side view of an end portion of the package shown in figure 9 with the slider removed;

Figure 22 is a front elevational view of the package of figure 9;

Figure 23 is an elevational view of a portion of a sealing bar used in the manufacture of the package of figure 9;

Figure 24 is a section on the line XXIV - XXIV shown in figure 23;

Figures 25 to 28 show, respectively, four different forms of end stomp which are alternatives to the end stomp of the zipper fastener of the package of figure 9;

Figures 29A and 29B show, in somewhat schematic perspective view, an apparatus for formation of an end stomp and cut-out of a zipper according to the present invention;

Figures 30A and 30B are front elevational views of the apparatus shown in figures 29A and 29B, respectively;

Figure 31 shows, in somewhat schematic perspective view, another apparatus for formation of an end stomp and cut-out of a zipper according to the present invention;

Figures 32 to 35 show further shapes of end stomps; and

Figures 36 to 38 show somewhat schematically respective stages in the formation of a cut-out of the zipper according to the invention.

Figure 1 shows a vertical form-fill-seal machine, generally as disclosed in US-A-4909017 (McMahon et al), the entire contents of which are incorporated herein by reference. The machine is modified in accordance with the present invention, as described herein. Figure 1 shows a machine which incorporates what is known as cross-web or transverse direction (TD) technology, in which zipper strips are applied to a packaging film in a direction transverse (in this case, perpendicular) to the direction of movement of the film. Transverse direction technology is to be contrasted with in-line or machine direction (MD)



technology, in which the zipper strips are applied in the direction of movement of the film. Examples of machine direction technology are provided by US-B-7213305 (Stolmeier et al), the entire contents of which are also incorporated herein by reference, and by the apparatus described herein with reference to figures 2 to 4 and 6 and 7 of the drawings hereof.

As shown in figure 1, a continuous supply of thin bag making film 110 is fed forwardly from a supply roll 101. The film is drawn forwardly by a suitable mechanism (not shown) which pulls the film downwardly to form it into a tube so that the contents of the formed bag can be dropped down through a filling tube into the tubularly formed bag.

As the film is fed forwardly to a form, fill and seal machine, a zipper strip assembly 116 is attached to the inner surface of the film. That is, it is attached to the surface which will be on the inside of the bag when the bag is formed into a tube. The zipper strip is fed laterally across the upper surface of the film at right angles to the longitudinal edges of the film or, in other words, at right angles to the longitudinal formation axis of the film.

The zipper strip provided from a supply roll 103 is fed through a guide 114 and into a channel 113. Suitable means are provided for cutting off a length of zipper strip from the supply and the length of the strip 116 is substantially equal to one-half of the film width.

The zipper strip includes two profile strips which are interlocked. One profile strip contains a groove and the other, an arrowhead shaped profile which is lockingly received in the groove. The rib and groove profile strips

are interlocked or joined before they are fed across the film. A guide mechanism shown generally at 112 includes the channel 113 which positions the zipper strip 116. The strip is attached to the film so that only the lower profile is secured to the film by bonding such as by applying heat from outside of the surface of the film. The first profile may be fully bonded or only tacked to the film, but as such will support the second profile which is interlocked thereto. The profiles are attached mid-way between the edges of the film 110 and lateral portions of the film beyond the ends of the zipper strips 116 are sufficiently long so that they can be folded over the top of the strips.

In accordance with the present invention, the apparatus shown in figure 1 incorporates a slider applicator which attaches sliders as described hereinafter with reference to figures 9 to 20 of the drawings to the zipper strip 116 as it passes from the supply roll 103 through the guide 114 to the channel 113. The slider applicator can be of any known kind, for example as obtainable from Zip-Pak UK of Stainsacre Lane, Whitby, North Yorkshire YO22 4PT, United Kingdom. The slider applicator is shown schematically by the reference numeral 140 in figure 1.

Also in accordance with the present invention, the apparatus shown in figure 1 is provided with a mechanism for the formation of end stomps at periodic intervals along the length of the zipper strip 116, such that each slider applied to the zipper length is located between a pair of end stomps. The portions of the zipper strip between successive pairs of end stomps are partially cut away by this mechanism, the strip being finally severed into

individual lengths by the cutting means referred to above. The mechanism for formation of the end stops is shown schematically in figure 1 by the reference numeral 142 and is described in more detail hereinafter with references to figures 29A, 29B, 30A and 30B of the drawings.

The film thus has fastener strips attached to the upper surface, extending laterally, at spaced intervals as shown by the further zippers 116a, 116b, 116c, 116d, 116e, 116f and 116g. Each zipper length 116a, 116b ... has respective a slider 117a, 117b ... mounted thereon and has an end stop (not shown) at each of its ends. The end stops are described in more detail hereinafter with reference to figures 21 to 28 and 32 to 35 of the drawings.

The film is fed downwardly over shaping shoulders 121 to guide the film over a vertical forming and filling tube 124 of a vertical form-fill-seal machine. The edges of the film are brought together and are pressed together by rollers 125 to form a flange seam. The seam is welded by heated welding bars 122 and 123 which are brought together against opposite sides of the fin seam 137 which is formed. Contents are then dropped through the tube 124 into the tubular formed bag which has a lower seam 129.

As the film is formed into tubular shape, the fastener strips slide over the vertical form fill tube 124. As it moves downwardly, the tube is flattened. It will be noted at this point that only the first profile strip is secured to the inner surface of one side wall of the bag.

When the contents are in the tube, having been dropped downwardly through the filling tube 24, the top of the bag is completed. This completion involves a number of

operations which are performed simultaneously by sealing and cutting bars 127 and 128 which are moved against the outer surfaces of the tubular film by mechanism, not shown.

The bars 127 and 128 secure the profile strips to the inner surface of the bag. The bar 127 has a heated sealing bar 132, and the bar 128 has a heated sealing bar 131. These move against the profile strips applying heat to the outer surface of the film causing the film to be heat sealed to both strips. While the film has already been sealed to one of the profile strips by the mechanism 112, it may be that the strip at this point was only tacked to the film so that a full heat seal is accomplished by the bar 131. The second profile strip has been free of attachment to the opposing bag wall, but at the location shown, the bar 132 moves against the film and causes it to be heat welded to the second zipper strip.

Above the interlocked zipper strip 116, the opposing bars 127 and 128 seal both the top of the prefilled package and the bottom of the next succeeding package. The bars 127 and 128 each have a raised heated portion 127a and 128a which form a seam for the bottom of the next succeeding bag. The portions 127b and 128b of the bars 127 and 128 join the layers of film to form a seam above the zipper strip 116. This seam is a pilfer-evident closure for the bag and the seam can be removed cut off the top of the bag before the bag is to be used.

Located in the centre of the bars 127 and 128 is a knife 128c which cuts the plastic film with the knife pressing against an anvil 127c. This separates the lower filled bag from the formed tube above permitting it to drop down as shown in figure 1 wherein a cross-seam 133 is

formed at the bottom of a bag, a zipper fastener 134 is at the top of the bag, and a pilfer-evident seal 135 is above the fastener.

In operation of the machine shown in figure 1, a length of the film 110 is moved forward incrementally and at spaced intervals, assembled zipper strips such as 116 and 116a are secured to the upper surface of the film with only one of the interlocked strips joined to the surface of the film.

The film is then pulled forward and formed into tubular shape over a form fill tube 124 and the edges of the film are joined in the seam 137. The zipper strips 116, 116a, etc lie along one inner wall of the tube, out of the way when contents are dropped into the bag through the form fill tube 124.

The bars 127, 128 are brought laterally against the tube clamping it, and these bars are moved downwardly to pull a fresh length of film down over the tube 124. The bars 127, 128 also function by means of the heated portions 127a, 127b to apply heat to the outer surface of the film and thereby join the second profile strip of the film and to the opposite wall of the bag. The bars also have spaced heating faces to form cross-seams across the film with the lower seam providing a pilfer-evident closure at the top of the bag and the upper seam forming a bottom seam for the next succeeding bag. The knife 128c carried by the bar 128 severs the film between the cross-seals so as to cut off a filled bag and allow it to drop.

As an alternative to the zipper applicator described hereinbefore and shown in figure 1 of the drawings, a

rotary turret applicator as disclosed in WO-A-2005/092139 (Supreme Plastics), the entire contents of which are incorporated herein by reference, may be employed.

Figures 2 to 4 of the drawings shows a vertical form-fill-seal machine generally as disclosed in US-A-4709533 (Ausnit), the entire contents of which are incorporated herein by reference. The machine is modified in accordance with the present invention, as described herein. As shown in figure 2, a sheet of thin plastics film 210 is provided from a suitable continuous supply (not shown) and threaded over a roller 211 to be guided in turn over a forming collar 209 to pass downwardly over a cylindrical filling spout 212. Lateral guides may be provided to stabilize and help guide the film into tubular form over the spout 212 which has an upper end through which contents are deposited to drop downwardly into the tube to be contained in bags being formed. The contents will then drop downwardly through the lower end of the spout into individual bags which are cross-sealed and cut from the end of the tube so-formed.

In the formation of the tube, lateral edges 213 and 214 of the film are brought together to form a fin seal which will become the bag top. For guiding the edges and pressing them together for the fin seal, rollers 215 and 216 draw and guide the material downwardly and the rollers are provided with suitable means for driving them in rotation. The rollers have enlarged pressure portions 215a and 216a to press the edges 213 and 214 of the film together for initiation of the film fin seal.

At the same time, joined fastener profiles of a zipper 218 are fed downwardly between the edges of the film as the

edges are brought together thereby sandwiching the zipper profiles therebetween. The zipper 218 is supplied from a roll 217 over a guide roller 219 to position it directly vertically over the edges which are being brought together.

In accordance with the invention, the apparatus shown in figure 2 incorporates a slider applicator, shown schematically at 242, and an end stomp formation mechanism shown schematically at 244, located between the supply roll 217 and the guide roller 219. The zipper 218 passes through the slider applicator 242 and end stomp formation mechanism 244 which are each as described above with reference to figure 1. The zipper thus has sliders (not shown in figure 2) as described with reference to figures 9 to 20 mounted thereon at spaced intervals therealong. Each slider is positioned between the end stomps of a pair of end stomps which lie at respective ends of the zipper closure of each completed package formed on the apparatus of figure 2. The portions of the zipper strip 218 between successive pairs of end stomps are partially cut away and are severed into individual lengths later in the production process described below.

One form of the zipper is shown in detail in figure 4 where the zipper 218 has a male profile 220 and a female profile 221. The male profile has a rib 222 which is releasably interlocked in a groove 223 of the female profile. The zipper 218 being formed of flexible plastics releasably closes the top of the bag which is eventually formed and is reopenable by drawing apart the lips in a manner which is known to those versed in the art. Alternatively, the zipper may be as described with reference to figures 9 to 12 hereof.

The male profile 220 of the zipper strip has upper and lower flanges 220a, 220b. The female profile 221 has upper and lower flanges 221a, 221b. These flanges are attached, preferably by heat sealing, to the inner surface of the film 210 to provide a permanent attachment between the zipper and the top of the bag.

By using the flanges to seal the zipper to the film, a broad area of attachment is made available, thereby creating the possibility of a strong bond between zipper and film. In addition, because of the width of the sealing area available, more tolerances in the alignment between the zipper web and film are permissible. Both of these functions allow for greater ease of manufacture.

To accurately guide the zipper 218 and ensure its continual parallel relationship to the edges 213, 214 of the film, outer and inner bars 225, 226 are located between the flanges of the zipper profiles 220, 221. The bars 225, 226 are spaced sufficient to allow the joined rib and groove 222, 223 to pass therebetween and the inner edges of the bars provide a channel which positively locates the rib and groove and ensures that it will travel vertically a relatively exact distance from the edges 213, 214 of the film. The bars 225, 226 also separate the two film layers and the respective flanges of each zipper profile from each other. The outer bar 225 is suitably mounted on a frame, not shown, and the inner bar 226 is attached to and supported on the spout 212 as shown in figure 4.

For purposes of heat sealing the zipper to the film and for forming the fin seal at the outer edges of the film, a simultaneous sealing operation is conducted by opposed sealing blocks 227, 228. These sealing blocks



extend vertically positioned so that the film edge with the zipper sandwiched therebetween is drawn downwardly between the bars 227 and 228. Means for drawing down the film is provided but not shown.

The sealing bars 227, 228 are suitably heated such as by heat elements 229, 230 passing down therethrough.

The bars 227, 228 are shaped with outer projections which form the fin seal at 224. Inwardly of the projection are recesses which are sufficiently deep to accommodate the positioning bars 225, 226. The inner surfaces of the sealing bars 227, 228 apply heat to the film to form the fin seal at 224 and to join the flanges of the zipper profiles 220, 221 to the inner surface of the film. The film surfaces, except where they are joined to each other at 224 are kept separated by the positioning bars 225, 226. This prevents the zipper flanges and film layers from being sealed together. Rectangular grooves 227a and 228a, shown in figure 24 and 25, provide a space opposite the rib and groove elements so that heat is not transmitted to the rib and groove elements to avoid softening the plastics material to an extent where the plastics material might inadvertently permanently join the rib to the groove.

Essentially there is a dual function formed by the guide bars 225, 226 in that they position the zipper profiles and also provide a shoulder over which the film is drawn by the press rollers 215, 216. As the edges of the film are brought together by the press rollers 215, 216, the film is pulled slightly taut over the outer edge of the outer bar 225 thereby drawing the film firmly around the cylindrical spout 212.

The edges of the outer blocks 227, 228 extend fully up to the spout 212 so that the film is pulled firmly about the spout as it passes downwardly. The zipper 218 is thus located close to the filling spout. This closeness allows the tube to be completely filled with contents against the zipper as the lower end 212a of the spout is passed.

Before a charge of contents is dropped down through the spout 212 into the tube which has been closed as it passes the lower end of the blocks 227, 228, a cross-seal and cut are formed to complete the bag.

The cross-seal and cut are formed by opposed sealing bars 231, 232 which have a recess therein to provide laterally extending but vertically spaced seals. A knife 233 is located in the recess to provide a cut between the seals, and as each cross-seal is made and each cut is made, a bag is severed from the continuous tube. At this point in the process, the partially cut-away portions of the zipper strip lying between successive pairs of end stomps are cut-through by the knife 233 to leave the zipper of each bag having a length of zipper on which is mounted a slider 242 positioned between a pair of end stomps 244a, 244b, shaped as described hereinafter. The completed bag is shown at 234 with a bottom 240 and with side edges 236, 237 formed by the sealing bars 231, 232. The top of the bag has the security fin seal 238 and immediately inwardly of the fin seal is the interlocked zipper 239.

In operation, the film material 210 is continually fed into a tubular shape over the spout 212. As the material is drawn downwardly, it is pressed at its edges 213, 214 between the pressure rollers 215, 216 which pull the web over the outer edge of the outer guide bar 225. The guide

bars 225, 226 guide the zipper vertically in an accurate position adjacent the outer edges 213, 214 of the web and adjacent the filling tube 212. The outer heating blocks 227, 228 simultaneously seal the film to the webs of the zipper and form the fin seal at the outer edge above the zipper. The thus sealed edge of the tube forms the top of the bags which are sealed and cut from the length of the tube by the bars 231, 232 and the knife 233.

Figure 5 of the drawings shows the general arrangement of a horizontally-operating form-fill-seal packaging machine which includes a zipper applicator which is indicated by the reference numeral 330. The machine is modified in accordance with the present invention. The zipper applicator is as described in WO-A-2005/070661 (Supreme Plastics Holdings Limited), the entire contents of which are incorporated herein by reference. Figure 5 further shows a thermoplastic film 310 which is stored in a roll 352 which can rotate to allow the film to be drawn by a pair of feed rollers 354a, 354b through the zipper applicator 330, whence it passes around further guide rollers 356a, 356b before being fed to a forming box 358 as is conventional in horizontal form-fill-seal packaging machine. Articles 360 to be packaged are fed in the direction E shown by an arrow on a conveyor belt 362 to the forming box 358, where, in the conventional manner, the film 310 is folded around the article 360 and the longitudinal edges of the film 310 are brought together and sealed to each other to form a back seal. Subsequently to this, and at a location downstream of the forming box 358, the folded film passes between a pair of heated cross-seal jaws 364a, 364b which form transverse seals between the inner faces of the folded film and also sever the film to

provide individual sealed packages 366 containing the articles 360.

The zipper applicator 330 comprises a zipper applicator bar 322 which receives lengths of zipper 326 from a storage roll 328 and works with a heating sealing bar 334 to attach zipper lengths to the film 310 at predetermined intervals, the zipper lengths extending perpendicularly to the length of the film 352. The zipper is fed to the film by a pair of rollers 330a, 330b, through the nip of which the zipper passes. A knife 332 cuts the zipper into appropriate predetermined lengths.

In accordance with the invention, the apparatus shown in figure 5 incorporates a slider applicator, shown schematically at 370, and an end stomp formation mechanism shown schematically at 372, located between the zipper storage roll 328 and the feed rollers 330a, 330b. The slider applicator may be as referred to above. The end stomp mechanism may also be as referred to above. The zipper 326 passes through the slider applicator 370 and the end stomp formation mechanism 372 which are each as described above with reference to figure 1. The zipper lengths supplied to the zipper applicator 330 thus have sliders (not shown in figure 5) as described with reference to figures 9 to 20 mounted thereon at spaced intervals therealong. Each slider is positioned between the end stomps of a pair of end stomps which lie at respective ends of the zipper lengths.

It should be mentioned that, in accordance with cross-web ("TD") technology, the zipper 326 is cut into lengths which are slightly less than one-half of the width of the film 310, the male and female profiles of the zipper

lengths being engaged with each other. The lengths of the zipper are located by the applicator bar 322 centrally of the film 310. Thus, when the film is folded in the forming box 358, the portions of the film to each side of the zipper length form the sides and one face of the eventual package. The length of zipper is attached to what becomes the inner face of the package, so that, by the operation of the cross-seal bars 364a, 364b, heat is applied to the first face of the package to seal the zipper strip to that face and, after that, the film is severed into individual packages. The packages thus have a transverse heat seal at each end and, positioned inwardly of one of the seals, an openable and reclosable seal formed by the zipper strips for use after opening of the package by breaking the adjacent heat seal.

Figures 6 and 7 of the drawings show a horizontal form-fill-seal machine to which zipper is fed longitudinally in the direction of movement of a thermoplastic film which is also fed to the machine. The machine is generally as described in US-B-6526727 (McMahon et al), the entire contents of which are incorporated herein by reference, but modified in accordance with the present invention.

Referring now to figure 6, forming film 412 is indexed off a coil 414 of the film in a package-forming direction. Downstream of the forming film coil 414 at a forming station 415 the forming film 412 is thermoformed, using techniques well-known to those of ordinary skill in the reclosable packaging art, into a chain 413 of advancing box-like bottom portions or trays 416 of what will ultimately be completed packages. Product may then be loaded into the bottom portions 416 at a loading station

417 if desired. After optional product loading, a top film 418 is indexed off a coil 420 of the same in the package-forming direction, laid over the advancing bottom portions 416 and sealed thereto around the perimeter of the bottom portions at a sealing station 421 to form a sealed package 429. The seal at the package opening takes the form of a peel seal so that the consumer can easily gain access to the contents of the package.

After the top film 418 is sealed to the bottom portion 416 at the sealing station 421, the package chain 413 enters a zipper and slider insertion and attaching station 434, shown in cross-section in figure 7. At this station 434 film extensions 430, 432 of the leading package are spread apart from each other and interlocked reclosable zipper 436 supplied from a coil 438 of the same is fed between the film extensions 430, 432, as shown in figure 7, which is a cross-sectional view of the package chain and zipper and slider insertion and attaching station 434. The zipper is comprised of two interlocking closure profiles 439, 441 with flanges 440, 442 extending therefrom which are sealed to the film extensions 430, 432, such as by a pair of seal bars (not shown). After the zipper 436 is thus sealed to the film extensions of the leading package, the zipper 436 is stomped at each end of the package by a stomping apparatus which is described in more detail hereinafter with reference to figures 31 of the drawings. The stomping apparatus is shown schematically in figures 6 and 7 by the reference numeral 450. The purpose of the stomping apparatus 450 is to provide end stops for the slider and to ensure that the ends of the zipper 436 do not come apart during use.

A slider 444 (described in detail with reference to figures 9 to 20) is then removed from a coil 446 thereof and inserted on to the zipper 436 by a slider insertion apparatus shown schematically by the reference numeral 452 in figures 6 and 7. The slider and zipper are designed such that the slider will open the zipper as the slider is moved along the zipper in an opening direction towards an opening end of the zipper and close the zipper as the slider is moved along the zipper in a closing direction towards a closing end of the zipper. After mounting of the slider 444 on the zipper 436, the slider is slidable between a pair of end-stomps which are shaped as described hereinafter with reference to figures 21 to 28 or 32 to 35 of the drawings and which interact with the end stomps also as described. It is preferable during slider insertion that the slider be inserted at the closing end of the zipper since the zipper is initially interlocked. The slider will thus be positioned for normal functioning. If the slider is inserted at a location other than at the closing end, it will be necessary to actuate the slider by moving it to the closing end, after which the slider will be in position for normal functioning. Such actuation may be done on the HFFS machine, or it may be done by the initial package user.

After slider insertion, the leading package is cross-cut from the remainder of the chain 413 by any one of many commonly known kinds of cutting apparatus (not shown) to remove a completed package 448 having a slide zipper.

In a modification of the process described above with reference to figure 1 or figure 5, in which the zipper is attached to the film in a first step of a process of forming, filling and sealing bags, the attachment can be

carried out as part of a so-called "reel-to-reel" process in which the strip of film with zippers attached is formed into a roll of zippered film which is used subsequently in a bag-making process carried on a vertical or horizontal form-fill-seal machine. Such a process is shown schematically in figure 8 of the drawings in which the film 110' is fed from a supply roll 101' around a guide roller 116a, past a zipper-attachment device 112', incorporating a slider applicator 118 and an end-stomp formation mechanism 120, around a guide roller 116b to a take-up reel 115 on which the zippered film is rolled for subsequent use in a form-fill-seal machine as shown in figure 1 and described with reference thereto.

By a modification of the arrangement shown in figure 8, a pre-zippered film for use in an in-line (or MD) process can be produced. In such a modification, a continuous zipper strip having sliders attached at intervals therealong is attached to a strip of film parallel to one edge thereof and spaced inwardly therefrom. The film is then re-rolled for subsequent use in an apparatus, for example similar to that shown in figures 2 to 4. End stomps are formed in pairs at suitable intervals along the zipper strip, each slider being positioned between a pair of end stomps.

Figure 9 of the drawings shows a slider 10 fitted to a package 12 which is shown in full in figure 22. The slider is formed as a one-piece moulding of a suitable plastics material such as high-density polyethylene (HDPE), medium density polyethylene (MDPE), polypropylene, polyester or a polyacetal. The package 12 is a bag comprising front and rear panels 14, 16 of plastics material, such as may be produced as described above on a vertical form-fill-seal



(VFFS) machine as shown in figure 1 by passing a continuous rectangular web of the plastics material such as, for example, low density polyethylene (LDPE) or a suitable laminate, over a forming shoulder of the FFS machine to form the rectangular web into a tube, joining the longitudinal edges of the tube to form a back seal (18 in figure 22), lying at the mid point of the rear panel 16, and subsequently fastening and sealing the tube transversely to itself at bag-length intervals to form top 20 and bottom 22 seals of bags which are thus formed in a continuous string. After formation of the back, top and bottom seals 18, 20, 22, the individual bags are separated from the continuous string. Product may be introduced into the bags by being fed to the hollow interior of the forming tube below the forming shoulder. The back, top and bottom seals 18, 20, 22 are usually formed by the application of heat and/or pressure to the plastics material by means of suitably-shaped and positioned sealing bars, for example by way of the process described above with reference to figure 1. Alternative methods of bag formation is as described herein with reference to figures 2 to 8.

The present invention is however not limited to packages produced using vertical form-fill-seal machines. Packages embodying features of the invention can also be made using horizontal form-fill-seal (HFFS) machines, or in any other suitable manner. Moreover, the invention is not limited to packages produced using TD technology; the invention is also applicable to processes using MD technology, examples of which are described in US-B-7213305 referred to above and herein with reference to figures 2 to 4 and 6 and 7 of the drawings.

Each zipper length consists of two interengaging profiles which are at least partially engaged with each other at the time of application to the web. Application is typically by heat-sealing of one of the profiles to the web. By suitably arranging for the location of the top and bottom seals 20, 22 along the length of the tube formed on the FFS machine relative to the zipper lengths, it can be ensured that each bag is formed with a length of zipper 24 located just below its top seal 20 and correspondingly spaced above its bottom seal 22, as shown in figure 22.

The profile of the zipper which is initially unsecured to the web is secured to the web (now folded around the zipper to provide the rear wall of the bag) can be secured to the rear wall of the bag either before, as described with reference to figure 1 above, or after the string of bags has been severed into individual bags. A process in which securement takes place after severing is described in WO-A-2004/014731 (Supreme Plastics), the entire contents of which are incorporated herein by reference.

Similar packages may also be formed by use of apparatus as described herein with reference to figures 2 to 7 of the drawings.

Portions of the zipper profiles at each end of each zipper length are sealed to each other to form a conjoined end portion or "stomp" at each end of each zipper fastener. This is achieved by heat, pressure or ultrasonic energy, or by combinations of two or all thereof. In previously known packages each end stomp has had a rectangular shape, whereby the edges of the end stomps which face the opposite end stomp of each respective fastener are rectilinear and

extend perpendicularly to the longitudinal edges of the zipper profiles.

For reasons which will become apparent later in this description, in the package described, the inner edge of at least one, preferably both, of the end stomps of the zipper 24, although rectilinear, extends obliquely to the longitudinal edges of the zipper profiles, in a manner such that the end stomp extends further along the zipper in the direction towards the other end stomp at the longitudinal edge nearer the top of the bag, than at the opposite longitudinal edge, as will be evident from figure 21 of the drawings, where it can be seen that the zipper 24 has end stomps 50, 52, having respective inner end surfaces 84, 85 which are rectilinear and extend obliquely across the zipper 24 in such a way that each extends further along the top (as shown) edge of the zipper 24 than along the bottom edge.

It follows from the above description that, along its top edge, the package 12 is sealed in an openable and reclosable manner by a zipper fastener 24. The top, heat-sealed portion of the package can be formed as a tear-off strip defined by a laser score line, the portion being torn-off to gain access to the zipper. A tamper-evident feature is thus provided. As will be seen more clearly from figures 10 to 12 and 15 of the drawings, the zipper fastener 24 comprises first and second interengaging profiles 26, 28, the first 26 of which is formed with first and second continuous hook-shaped ribs 30, 32 and first and second continuous grooves 34, 36 each of which is positioned below (in the orientation shown in the drawings) a respective one of the hooked ribs 30, 32. The second profile 28 also has first and second continuous hooked ribs

38, 40, each of which is adjacent a respective continuous groove 42, 44, positioned above its respective rib 38, 40. The hooks of the hooked ribs 30, 32 and 38, 40 are directed downwardly and upwardly, respectively, so that, upon reception of the ribs 30, 32 of the first profile 26 in the grooves 42, 44 of the second profile, the ribs 38, 40 of the second profile 28 are received in the grooves 34, 36 of the first profile and the hooks of the ribs come into engagement with each other, as shown in, for example figure 3 of the drawings. The profiles 26, 28 are thus engaged with each other and can be released from such engagement by being pulled or forced apart, in order to open the fastener 24.

Each profile 26, 28 is formed with a respective dependent flange 46, 48 which is sealed to the plastics material of the respective front or rear panel 14, 16 of the bag during the bag-making process, as already described. As also already described, the end portions of the profiles 26, 28 are heat-sealed together at each of their ends to form what are known in the art as end stumps 50, 52.

The slider 10 is shown in more detail in figures 9 to 19 of the drawings. The slider 10 has first and second side walls 54, 55 which have respective external concave portions 56, 57 which are ribbed for convenient gripping between thumb and forefinger.

The side walls 54, 55 are joined at their upper ends by a roof portion 60 of the slider which extends between the side walls. Each side wall 54, 55 has a respective upper extension portion 62, 64 which extends beyond the roof portion 60 for engagement by machine elements which

squeeze the extension portions 62, 64 together in order to increase the separation of the lower parts of the side walls 54, 55 to facilitate the fitting of the slider on the zipper.

A throughpassage 66 is formed between the walls 54, 55 of the slider. The throughpassage 66 is open along its lower edge (as shown in the drawings) in order to allow it to receive the first and second profiles 26, 28 of the zipper fastener 24, as shown in figure 3 and described in more detail below. The slider 10 is mounted on the zipper 24 at a convenient point the process of production of the package. This may be before or after the zipper is attached to the web of plastics material. As an example of the former, a slider applicator device, such as may be obtained from Zip-Pak UK of Stainsacre Lane, Whitby, North Yorkshire, YO22 4PT United Kingdom, is located as described hereinbefore with reference to figures 1 to 7 of the drawings.

Located in the throughpassage 66 is a plough 68 of the slider. The plough 68 comprises a head portion 70 and a fin portion 75 which depends from the roof 60 of the slider 10 and has the head portion 70 at its lower end. As will be seen from figures 13 to 16, the fin portion 75 is offset from the head portion longitudinally of the throughpassage 66, such that the head portion 70 lies closer to the end of the throughpassage that is shown on the left in figure 9.

The head portion 70 of the plough 68 has a six-sided "arrow head" shape in transverse section. This shape produces first and second inclined lower surfaces 72, 74 and first and second internal upper surfaces 76, 77. The lower surfaces 72, 74 allow the head 70 to pass between,

and, in so doing, disengage if necessary, the first and second profiles 26, 28 when the slider is mounted on the zipper in a downward movement with the zipper passing into the throughpassage 66. The lower edges of the slider side walls 54, 55 are bevelled at 78, 79 to facilitate mounting of the slider on the zipper 24.

The upper surfaces 76, 77 of the head present shoulders, which engage behind longitudinal ridges on the zipper profiles 26, 28 to retain the slider on the zipper.

As will be evident from figures 10 and 15 in particular, the fin portion 76 lies between the confronting grooves 34, 36, 42, 44 and ribs 38, 40, 46, 48 of the profiles 26, 28, whilst the head portion 70 lies between the flange portions 46, 48 of the first and second zipper profiles. Thus, as the slider 10 is moved along the zipper profiles 26, 28 in the direction from left to right as shown in figure 1 of the drawings, the profiles are pushed apart by the head portion 70 of the plough 68 to separate the ribs 38, 40, 46, 48 and grooves 34, 36, 42, 44 of the zipper profiles 26, 28 from each other.

As will be most readily seen in figure 16 of the drawings, the throughpassage 66 narrows in the direction away from the plough portion 68 so that, upon movement of the slider 10 along the zipper profiles 26, 28 in the direction from right to left as seen in figure 9, the profiles are brought into engagement with each other, through the action of inward pressure on the profiles caused by the narrowing spacing between the inner surfaces of the slider walls 54, 55. As will be most evident from figures 14 and 19 of the drawings, the inner surfaces of the side walls 54, 55 of the slider are formed with wedge-

shaped protuberances 81, 82, the purpose of which is to locate the slider on the zipper.

As will be seen most clearly in figure 13 of the drawings, the slider 10 is shaped so that the throughpassage 66 has above the head portion 70 of the plough 68 a cavity 80 which is closed at its upper limit by a portion 84 of the roof 60 of the slider.

The purpose of the cavity 80 is that, when the slider 10 is at the limit of its sliding movement along the zipper fastener 24 in the zipper-closing direction, left-to-right as seen in figure 9 of the drawings, a portion of the adjacent end stomp 50 is received in the cavity 80. This allows the slider 10 to attain a position on the zipper fastener 24 such that there is no gap formed by unengaged portions of the zipper profiles 26, 28 between the slider 10 and the end stomp 50. A more air-tight and secure closing of the zipper is thereby obtained. Also, there is no unsightly gap between the slider 10 and the end stomp 50.

To facilitate reception of a portion of the end stomp 50 in the cavity 80 in the slider 10, the end stomp is formed as shown in figures 9, 21 and 22 of the drawings, to which reference should now be made.

Figures 9 and 21 show the end stomp 50 formed at the left-hand end of the zipper fastener 24. A similar, mirror-image end-stomp 52 is formed at the opposite end of the fastener, as can be seen in figure 22. It will be noted that the inner end surface 84 of the end stomp 50 extends obliquely across the zipper profiles 26, 28. In other words the end stomp 50 has a greater extent along the

zipper fastener, in the direction away from the adjacent end of the fastener, adjacent the top edge of the zipper than adjacent the bottom edge. In other words, length "A" on figure 21 is greater than length "B".

This shaping of the end stomp allows a triangular portion shown hashed at 86 in figures 9 and 21 to be received in the slider cavity 80 with the effect described above.

The end stomp 52 at the opposite end of the fastener 24 is shaped similarly to the end stomp 50, but is its mirror image. It may be convenient to shape both end stomps of a fastener in this way, although only one end stomp interacts with slider in the manner described.

The shapes of the end stomps 50, 52 of the package described can be produced as part of the process of manufacture of the package 12 by suitable formations on the heated welding bars 127, 128 of the apparatus shown in figure 1 and described above. Figures 23 and 24 show a modified sealing bar 90 in which a raised end portion 92 is shaped to form the end-stomp. The raised end portion has a edge formed by a step 94 which is shaped to form the end-stomp 50.

The shapes of the end stomps 50, 52 of the fastener need not be as shown in figures 9, 21 and 22. Other shapes are possible within the scope of the invention provided that the distance corresponding to the distance A in figure 13 is greater than the distance B. Figures 25 to 28 show examples of such shapes. Figure 25 shows a square-edged step shape; figure 26 shows a curved edge; figure 27 shows



a more complex stepped shape; figure 28 shows a more complex curve.

In other processes and apparatus according to the invention, the end-stomps may be formed by suitable upstanding formations on the welding bars 127, 128 of a vertical form-fill-seal machine as shown in figure 1.

Otherwise, in a machine as shown in figure 1, the end-stomps may be formed by suitably-shaped heating and/or crushing devices as the zipper lengths are applied by the applicator 112, or prior to being fed to the applicator 112 in which case the end stomps may be formed as the continuous zipper feed is cut into lengths for presentation to the film 110.

In a machine-direction apparatus as shown in US-B-7213305, the end stomps can be formed by a suitably modified horn and sealing plate used to form the end stomps in pairs prior to separation of the zipper into individual lengths.

Appropriate corresponding modifications can be made in other apparatus, whether it be TD, MD, horizontal, vertical, reel-to-reel, or bag-making or form-fill-seal.

In a further modification of the processes described, the form-fill-seal machines of figures 1 to 7 can be replaced by so-called bag-making machines which produce empty bags (known as pre-made bags) for subsequent filling with product. The bag-making machine may operate vertically or horizontally.

Figures 29A and 29B of the drawings show together, in somewhat schematic perspective view, the mechanism 142 for formation of the zipper end stumps in the apparatus described hereinbefore with reference to figure 1 of the drawings. Figures 30A and 30B are front elevational views of what is shown in figures 29A and 29B, respectively. The mechanism 142 comprises a first actuating cylinder 1130 which is arranged to cause reciprocating movement in the directions shown by the arrow 1132 of a crusher plate 1134 which is heated by heating means (not shown). The crusher plate 1134 faces a stationary backing plate 1136. A length of zipper 24 is fed between the crusher and backing plates 1134, 1136. The lowermost surface 1138 of the crusher plate 1134 is shaped so as form the desired shape of end stomp, for example any of shapes described hereinbefore with reference to figures 21, 25 to 28 or 32 to 35 of the drawings. In the particular case of the mechanism shown in figure 29A, the end stomps formed are shaped at their inner edges as shown in figure 21 but are shaped so that their outer edges extend parallel to their inner edges. The uppermost surface 1140 of the backing plate 1136 is formed to co-operate with the lowermost surfaces of the crusher plate 1134 in producing the desired end stomp shape.

Figures 29B and 30B show a second actuating cylinder 1142 of the mechanism 142. The second actuating cylinder 1142 is arranged to cause reciprocating movement in the directions shown by the arrow 1144 of a punch member 1146 which co-operates with a die member 1148, which is stationary below the zipper 24. The punch and die members 1146 and 1148 are shaped such that they cut from the zipper 24 a semi-circular piece of material from the profile portions 26, 28 of the zipper 24, leaving the flange portions 36, 48 intact.

The crushing device shown in figures 29A and 30A is arranged to form one end stomp of one zipper length and the adjacent end stomp of the next successive zipper length. The semi-circular cut-outs are formed by the punch device and lie therebetween. By appropriate modification of the shape of the crusher plate and backing plate, any other desired end stomp shape can be produced, for example a shape as shown in any of figures 21, 25 to 28 or 32 to 35 hereof.

Before being fed to the channel 113, the zipper 24 is cut into lengths across the cut-out portions formed by the punch device shown in figures 29B and 30B.

The mechanism shown in figures 29A, 29B, 30A and 30B and described herein can be used as the end-stomp formation mechanism 244 of the apparatus described with reference to figure 2, or as the end-stomp formation mechanism 372 of the apparatus described with reference to figure 5.

The mechanism shown in figures 29A, 29B, 30 and 30B is suitable for use in the apparatus of figures 1 to 5 because, in such apparatus, the zipper is fed intermittently to the film material.

Figure 31 of the drawings shows a combined crushing and punching mechanism which provides the end-stomp forming device of the apparatus described with reference of figures 6 and 7 of the drawings. In figure 31, parts corresponding to parts of figures 29A, 29B 30A and 30B are shown by the same reference numerals primed. In the mechanism of figure 31 the crushing and punching devices are linked by a linkage shown schematically at 1150 so that the two devices

can move as a unit in the direction shown by the double-headed arrow 1152 as the film moves in the direction of the arrow 1154. The end stomps and cut outs formed in the zipper 24 are shown somewhat schematically at the right-hand side of figure 31.

Figure 32 of the drawings shows another shape of end stomp which can be produced by a modified version of the apparatus shown in figures 29A, 29B, 30A and 30B or in figure 31. In this case, the end stomp is shaped as in figure 26 but with reversed curvature. It should of course be noted that figure 32 shows the adjacent end-stomps 1156, 1158 of two adjacent pairs of end-stomps, the respective slider being located to the right and left respectively of the end stomps shown in figure 32. Figure 23 shows one such slider. Figure 33 shows the slider adjacent the end-stomps 1156, 1158.

Figure 34 corresponds to figure 32 but shows end stomps having inclined portions 1160, to each side of a cut-out 1162.

Figure 35 corresponds to figure 32 but shows end stomps 1163, 1164 having stepped shapes as in figure 25.

Figures 36 to 38 of the drawings show successive stages in the rotary movement of a pair of rotary cutters which can be used instead of the apparatus shown in figure 31. Figures 36 to 38 show a zipper 24 which moves between first and second rotary cutters 1164, 1166 which are contrarotating. The cutters 1164, 1166 follow D-shaped paths having straight portions adjacent the zipper 24. The cutters are shaped to remove from the zipper the semi-circular portions described above with reference to figures

29B, 30B and 31. A similar pair of crushing heads (not shown) can be employed to crush the zipper and form end stops of any desired shape.

**CLAIMS**

1. A slider for mounting on a pair of interengagable profiles of a zipper fastener, the slider comprising a body having a longitudinal throughpassage for receiving the profiles; and

means for mounting the slider body on the profiles for longitudinal sliding movement therealong;

the throughpassage being open at the bottom to allow the zipper profiles to pass therethrough for mounting of the slider thereon and being shaped to bring the profiles of a zipper on which the slider is mounted into engagement with each other upon movement of the slider therealong in a first direction; and

the body having a plough portion located in the throughpassage and shaped to separate the said profiles from engagement with each other upon movement therealong in a second, opposite direction;

wherein the throughpassage is shaped to define a cavity adjacent the leading end thereof to receive a conjoined end portion of the profiles of a said zipper fastener when the slider is mounted thereon.

2. A slider according to claim 1, in which the cavity is located above the plough portion.

3. A slider according to claim 1 or 2, in which the body is shaped to define a roof portion which closes the top of the cavity.

4. A slider according to any preceding claim, in which the plough portion is formed at the lower end of a dependent support member which extends downwardly into the throughpassage.

5. A slider according to claim 4, in which the plough portion is formed to extend from the support member in the direction towards the leading end of the throughpassage.

6. A slider according to claims 4 or 5, in which the support member has the form of a web which is narrower than the plough portion in the transverse direction of the slider.

7. A slider according to any of claims 4 to 6, in which the plough portion has opposed, parallel side faces for contacting respective profiles of a zipper fastener in order to separate the profiles from interengagement.

8. A slider according to any preceding claim, in which the plough portion tapers inwardly to its lowermost edge.

9. A zipper fastener comprising a pair of interengagable profiles and a slider according to any preceding claim mounted thereon for longitudinal sliding movement therealong, the zipper profiles being joined to each other over a portion of their lengths adjacent at least one of their ends to form a conjoined end portion, at least a portion of which is receivable in the cavity in the throughpassage at the limit of the movement of the slider along the profiles in the first direction.

10. A zipper fastener according to claim 9, in which the conjoined end portion of the zipper profiles is shaped at its end adjacent the slider to extend a greater distance towards the mid-point of the zipper at the upper edge of the profiles than at the lower edge.

11. A zipper fastener according to claim 10, in which the edge of the conjoined end portion adjacent the slider extends obliquely across the fastener.

12. A zipper fastener according to claim 11, in which the said edge of the conjoined end portion is rectilinear.

13. A zipper fastener according to claim 12, in which the said edge extends at a angle to the longitudinal zipper edges which is less than 90 degrees.

14. A zipper fastener according to claim 13, in which the angle is less than 60 degrees.

15. A zipper fastener according to claim 16, in which the angle is between 30 degrees and 60 degrees.

16. A zipper fastener according to claim 11, in which the edge extends curvilinearly.

17. A zipper fastener according to claim 16, in which the curvilinear edge is convex towards the slider.

18. A zipper fastener according to claim 16, in which the curvilinear edge is concave towards the slider.

19. A zipper fastener according to claim 16, in which the curvilinear edge follows an ogee curve.

20. A zipper fastener according to claim 16, in which the edge has a stepped shape.

21. A zipper fastener according to claim 20, in which the stepped shape comprises at least two portions extending perpendicularly to the longitudinal edges of the profiles



and at least one portion therebetween extending substantially parallel thereto.

22. A zipper fastener according to any of claims 9 to 21, in which the zipper profiles are joined to each other over respective portions of their lengths adjacent the other end of the zipper to form a further conjoined end portion.

23. A zipper fastener according to claim 22, in which the edges of both conjoined end portions extend a greater distance towards the mid-point of the zipper at the upper edge of the profiles than the lower edge.

24. A zipper fastener according to claim 23, in which the edge of the further conjoined end portion adjacent the slider is shaped as defined in any of claims 11 to 21.

25. A zipper fastener according to any of claims 9 to 24, in which the zipper profiles respective interengaging formations extending therealong and dependent lower flanges between which the plough portion is located and against which it acts to separate the profiles from disengagement.

26. A zipper fastener according to claim 25, in which slider is in accordance with any of claims 4 to 8 and the support member lies between the interengaging formations when the profiles are separated.

27. A zipper fastener comprising first and second profiles which are releasably engagable and re-engagable with each other, each profile comprising a first longitudinally extending portion having formations for engagement with the first portion of the other profile and, laterally thereof, a second, flange portion for attachment of the respective profile to a substrate, the first portion

lying closer to a first lateral edge of the zipper and the second portions lying closer to a second lateral edge of the zipper, wherein the profiles have conjoined portions at spaced intervals along their lengths, the conjoined portions extending over at least a portion of the width of at least the first portion and being arranged in pairs at a first interval between the conjoined portions of each pair and a second interval between the pairs, at least one of the conjoined portions of each pair being shaped such that it extends a greater distance towards the other conjoined portion of the pair adjacent the first longitudinal edge of the said conjoined portion than adjacent the other.

28. A zipper fastener according to claim 27, in which the first interval is greater than the second interval.

29. A zipper fastener according to claim 27 or 28, having portions of reduced width located between the pairs of conjoined portions.

30. A zipper fastener according to claim 27, in which the portions of reduced width are formed by removal of material from the second portions of the zipper profiles.

31. A zipper fastener according to claim 30, in which the reduced-width portions formed by removal of portions of material which are substantially semi-circular.

32. A zipper fastener according to any of claims 28 to 31, in which both conjoined portions of each pair thereof are shaped such that they extend a greater distance towards the other conjoined portion of the pair adjacent the first longitudinal edge of the said conjoined portion than adjacent the other.

33. A zipper according to any of claims 27 to 32, in which the said one of the conjoined portions is shaped such that its edge facing the other conjoined portion of each pair is shaped as defined in any of claims 11 to 21.

34. Apparatus for attaching zipper fastener comprising first and second interengagable profiles to a substrate, the apparatus including means for feeding the fastener to the substrate, means for attaching it to the substrate and means for forming pairs of conjoined portions of the profiles at intervals along the length of the fastener, the means for forming the conjoined portions being such that at least one of the conjoined portions of each pair is shaped at its edge facing the other conjoined portion to extend a greater distance towards the other portion at a first longitudinal edge of the zipper than at the second longitudinal edge thereof.

35. Apparatus according to claim 34, in which the means for forming the conjoined portions are such that both conjoined portions of each pair are shaped at their edges facing the other conjoined portion to extend a greater distance towards the other portion at a first longitudinal edge of the zipper than at the second longitudinal edge thereof.

36. Apparatus according to claim 34 or 35, including means for forming reduced-width portions of the zipper between adjacent pairs of conjoined portions.

37. Apparatus according to any of claims 34 to 36, in which the means for forming the conjoined portions comprise first and second members shaped to form the conjoined end portions and to crush the zipper therebetween.

38. Apparatus according to claim 37, in which the means for forming the reduced-width portions comprise die and punch members, between which the zipper is arranged to pass.

39. Apparatus according to claim 37, in which the means for forming the reduced-width portion comprise first and second rotary cutters, between which the zipper is arranged to pass.

40. Apparatus according to any of claims 36, 38 and 39, in which the means for forming the conjoined end portions and the means for forming the reduced-width portion are arranged to move as a unit longitudinally of the zipper.

41. Apparatus according to any of claims 38 to 40, including means for severing the zipper fastener into individual lengths at locations between adjacent pairs of conjoined portions.

42. Apparatus according to claim 41, including means for severing the zipper fastener into individual lengths at the reduced-width portions.

43. Apparatus according to claim 41 or 42, arranged to attach the zipper lengths to a substrate transversely to the direction of movement of the substrate.

44. Apparatus according to any of claims 38 to 40, arranged to attach the zipper in a continuous length in the direction of movement of the substrate.

45. Apparatus according to any of claims 38 to 44, including means for mounting sliders on the fastener between the conjoined portions of each pair thereof.

46. Apparatus according to any of claims 38 to 45, which is a form-fill-seal apparatus.

47. Apparatus according to any of claims 38 to 45, which is an apparatus for making unfilled packages.

48. Apparatus according to any of claims 38 to 45, which is an apparatus for applying lengths of zipper fastener to a continuous elongate substrate at spaced intervals therealong and transversely to the substrate.

49. A recloseable package having a zipper fastener according to any of claims 11 to 33.

50. An elongate web of flexible plastics material having first and second parallel longitudinal side edges and, spaced at regular intervals therealong lengths of zipper fastener according to any of claims 11 to 26, each being positioned approximately mid-way between and extending transversely to the side edges of the web and having a length which is approximately one-half of the width of the web.

51. A method making reclosable packages in which a web according to claim 50 is formed into a tube, the tube is flattened and sealed transversely at intervals such that a length of zipper is located between and adjacent to successive seals, the tube is severed into individual packages and, before or after severing, the zipper lengths are secured to the confronting surface of the web when formed into a tube.

52. A zipper fastener comprising a pair of interengagable profiles joined to each other over a portion of their lengths adjacent at least one of their ends to form a conjoined end portion, at least a portion of which is receivable in the cavity in the throughpassage at the limit of the movement of the slider along the profiles in the first direction, the conjoined end portion being shaped as defined in any of claims 11 to 21.

53. A sealing bar for use in the production of a zipper fastener according to claim 52, the sealing bar having at least one raised end portion which is shaped to join the zipper profiles to each other over a portion of their lengths adjacent at least one of their ends to form a conjoined end portion which is shaped as defined in claim 52.

54. A zipper fastener substantially as hereinbefore described with reference to the drawings.

55. A slider for a zipper fastener, the slider being substantially as hereinbefore described with reference to the drawings.

56. A method of attaching zipper fasteners to a substrate, the method being substantially as hereinbefore described with reference to the drawings.

57. Apparatus for making packages, the apparatus being substantially as hereinbefore described with reference to the drawings.

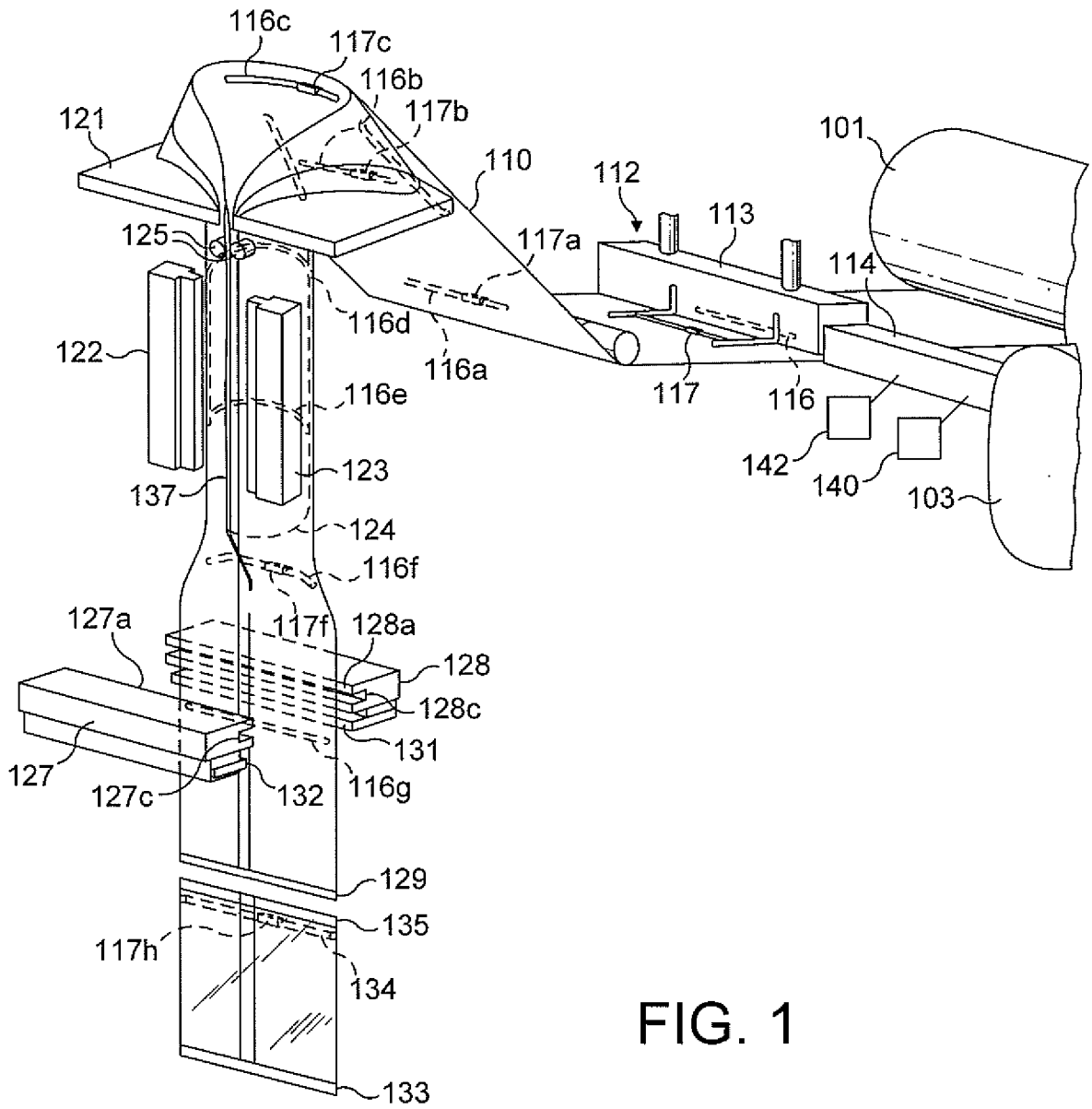

FIG. 1

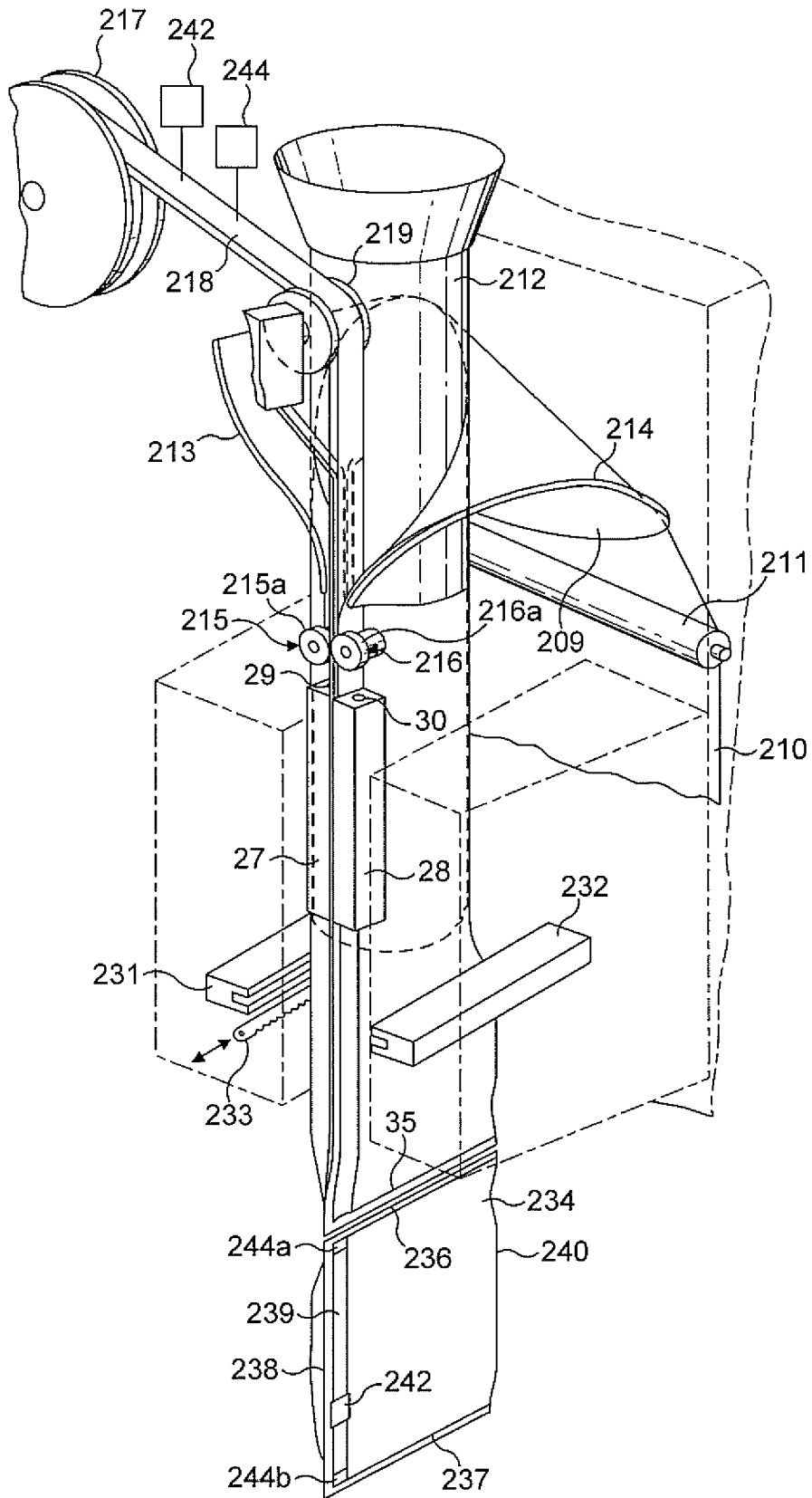

FIG. 2



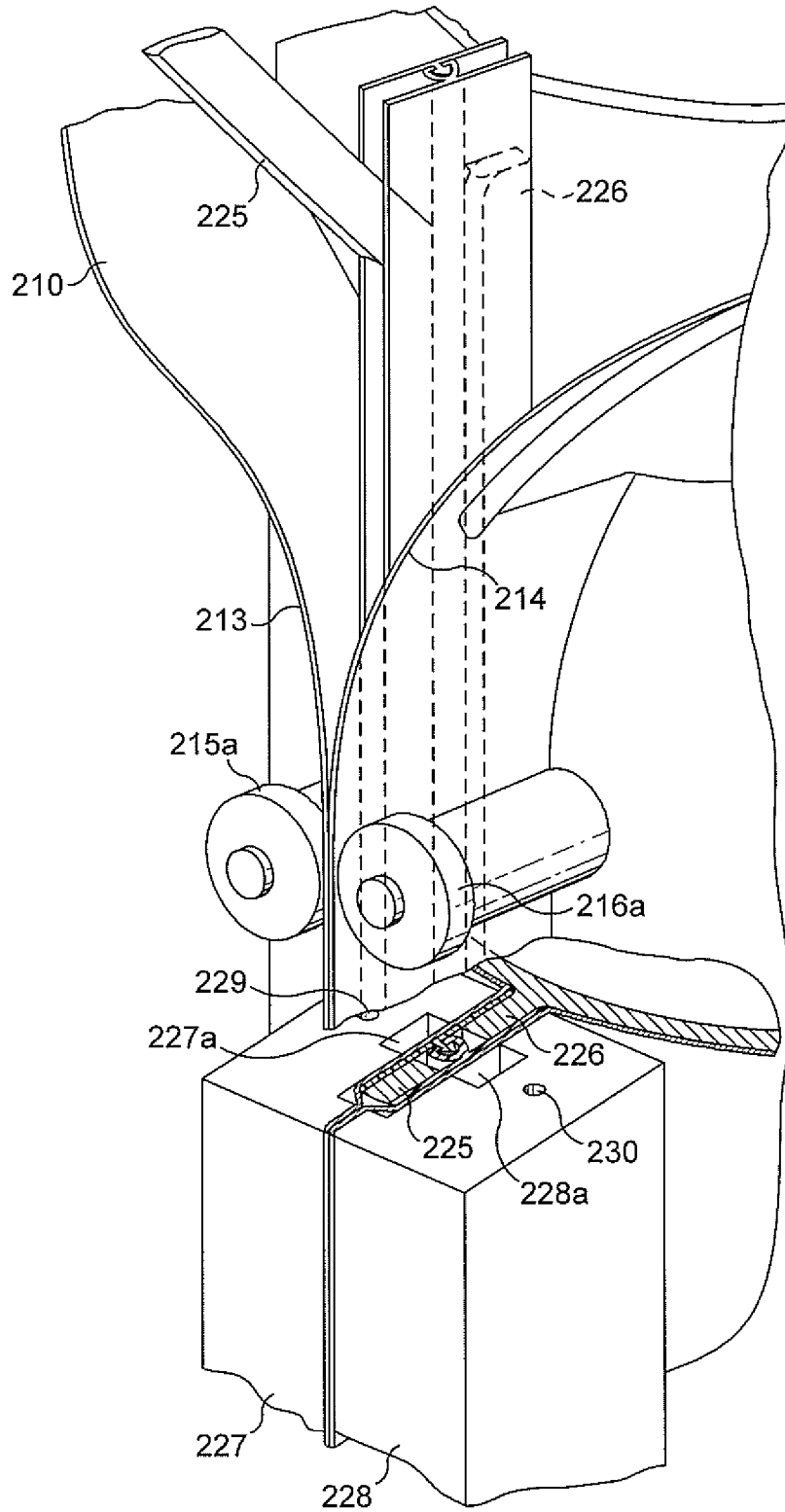

FIG. 3

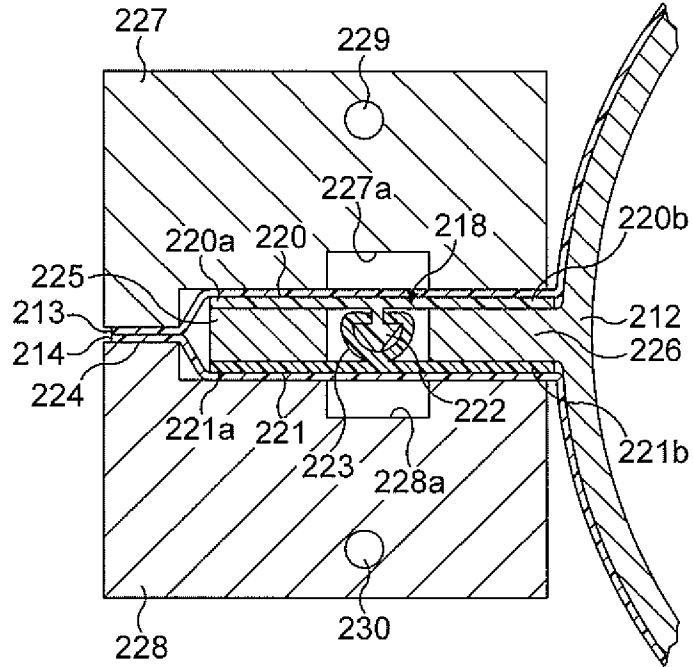

FIG. 4

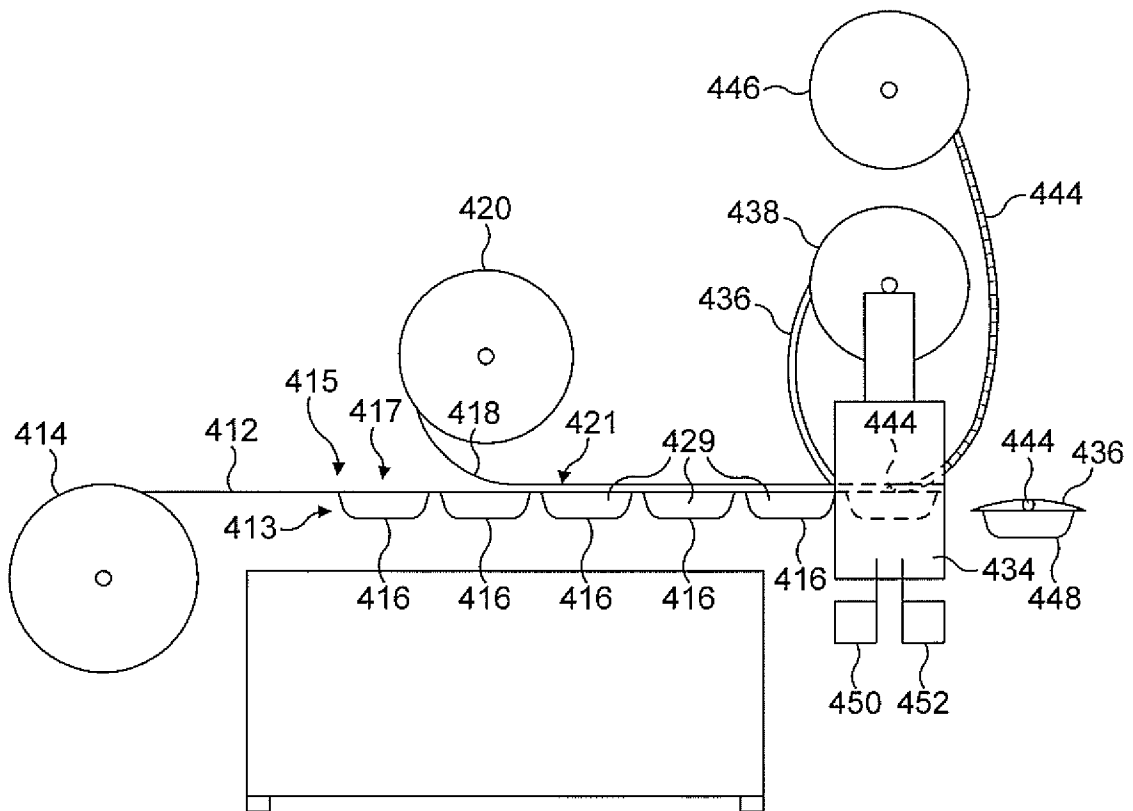

FIG. 6

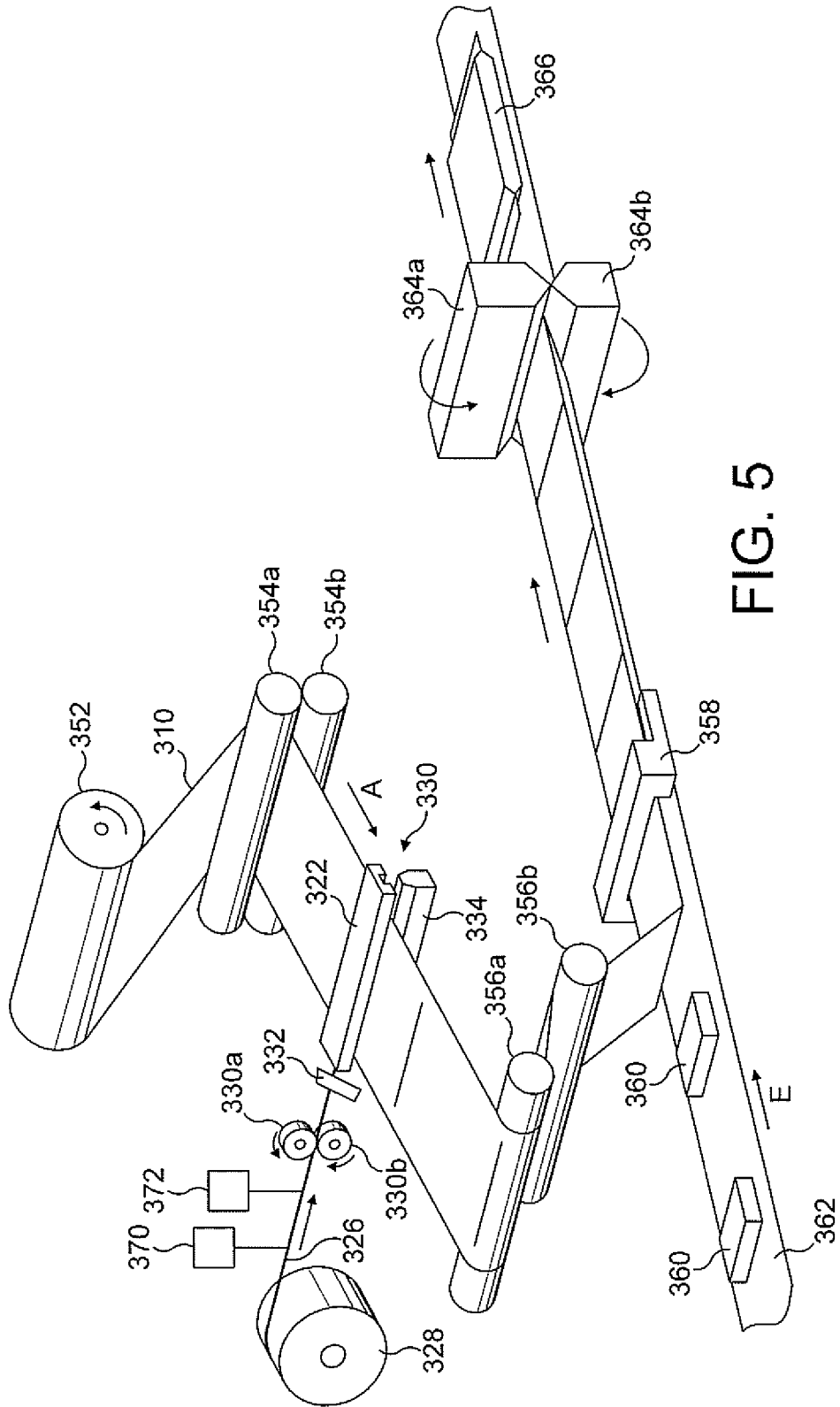

FIG. 5

6 / 19

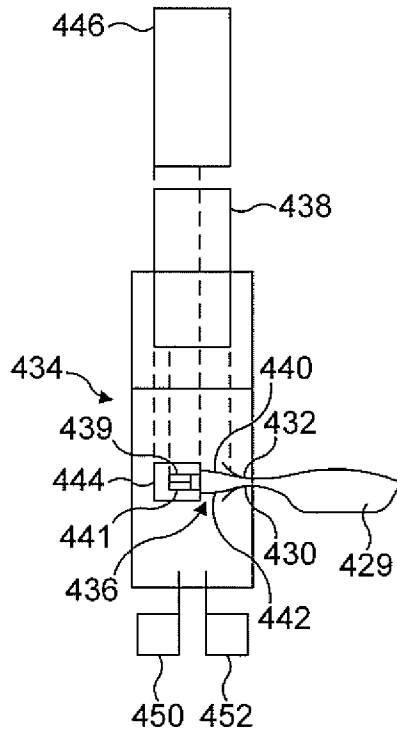

FIG. 7

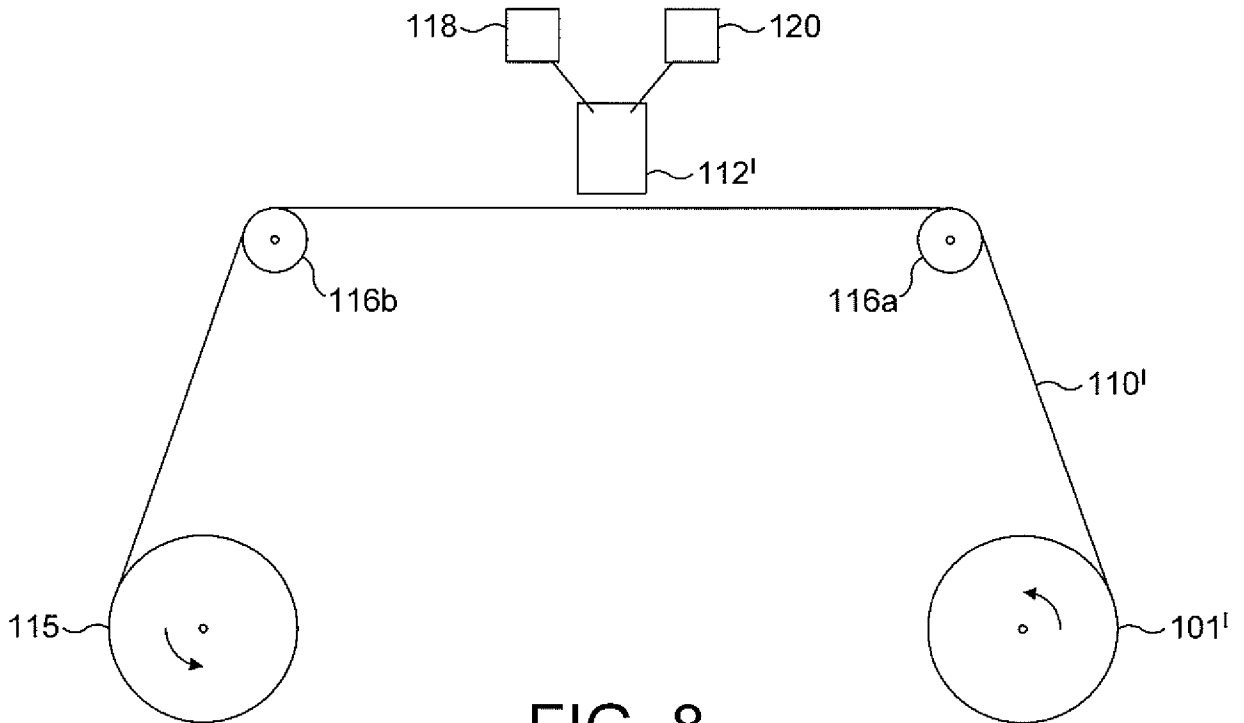

FIG. 8

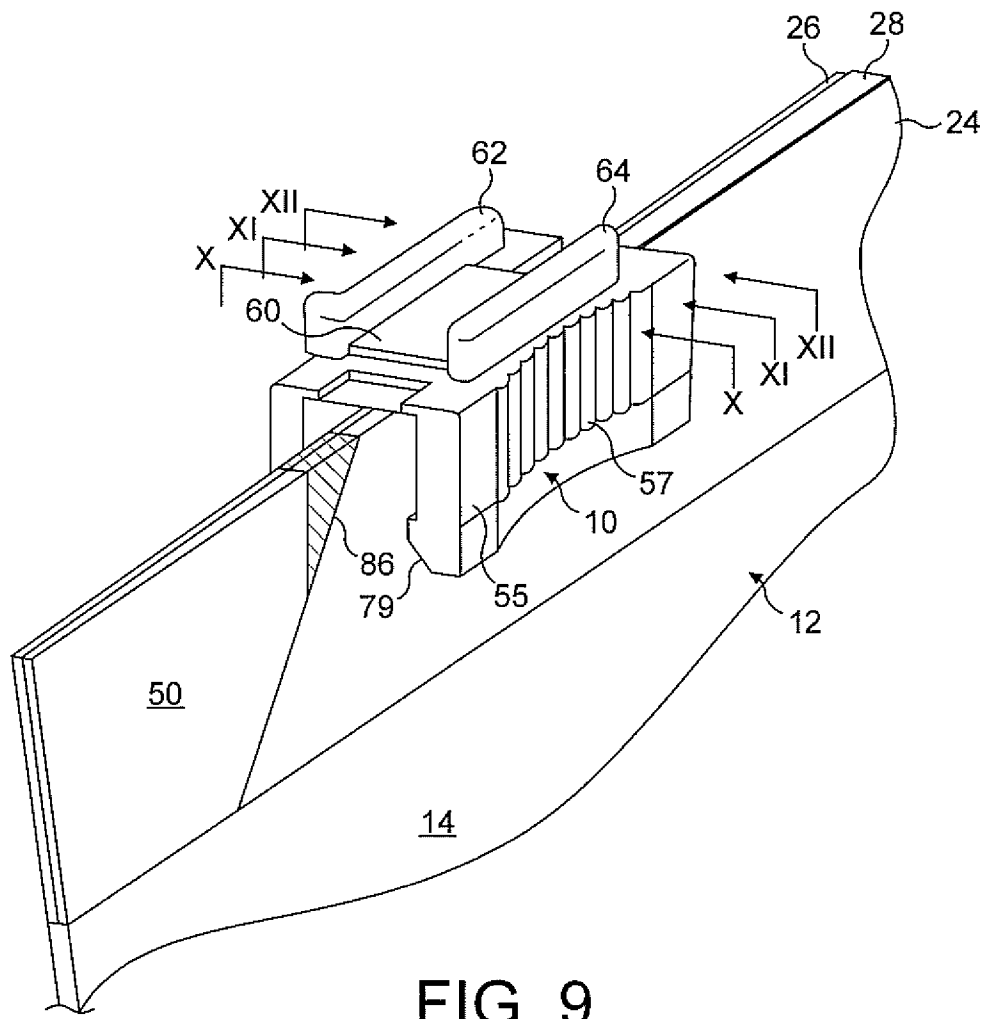

FIG. 9

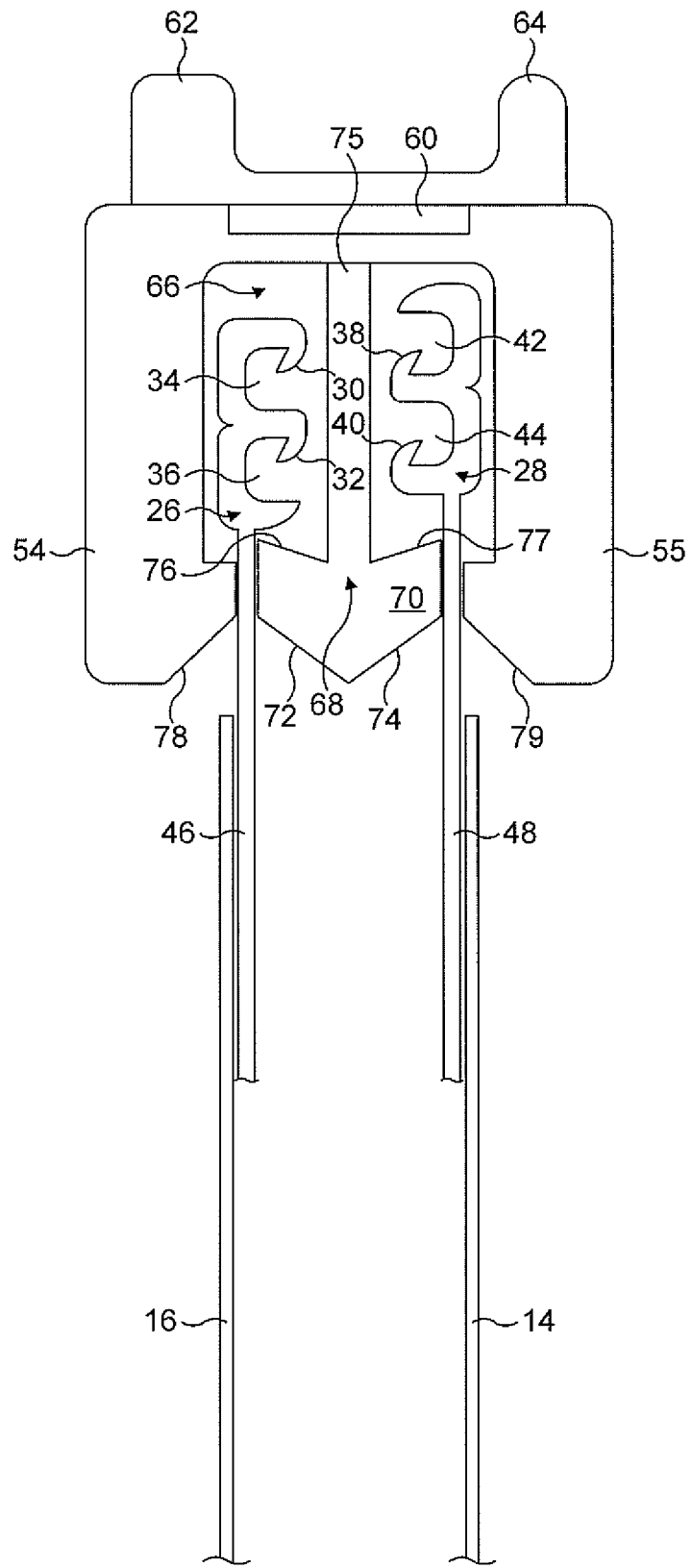

FIG. 10

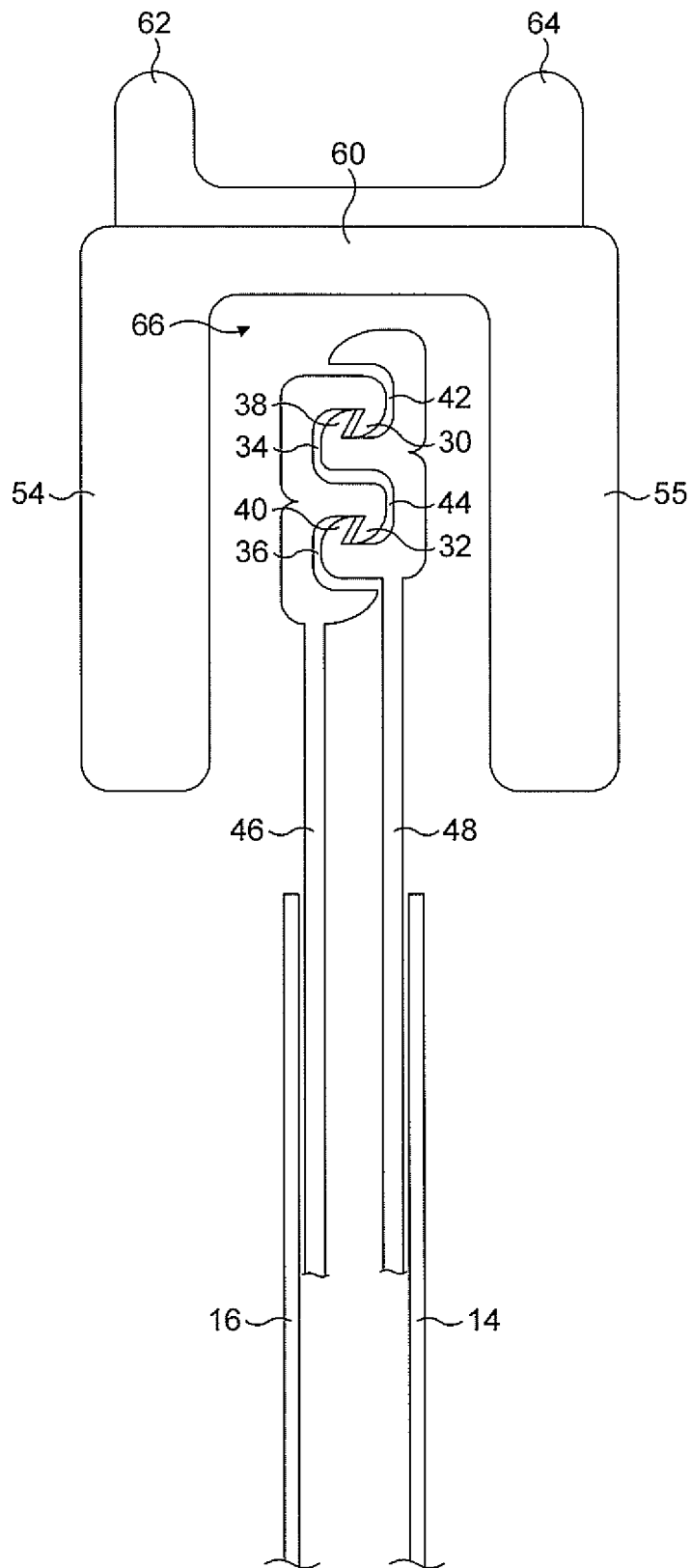

FIG. 11

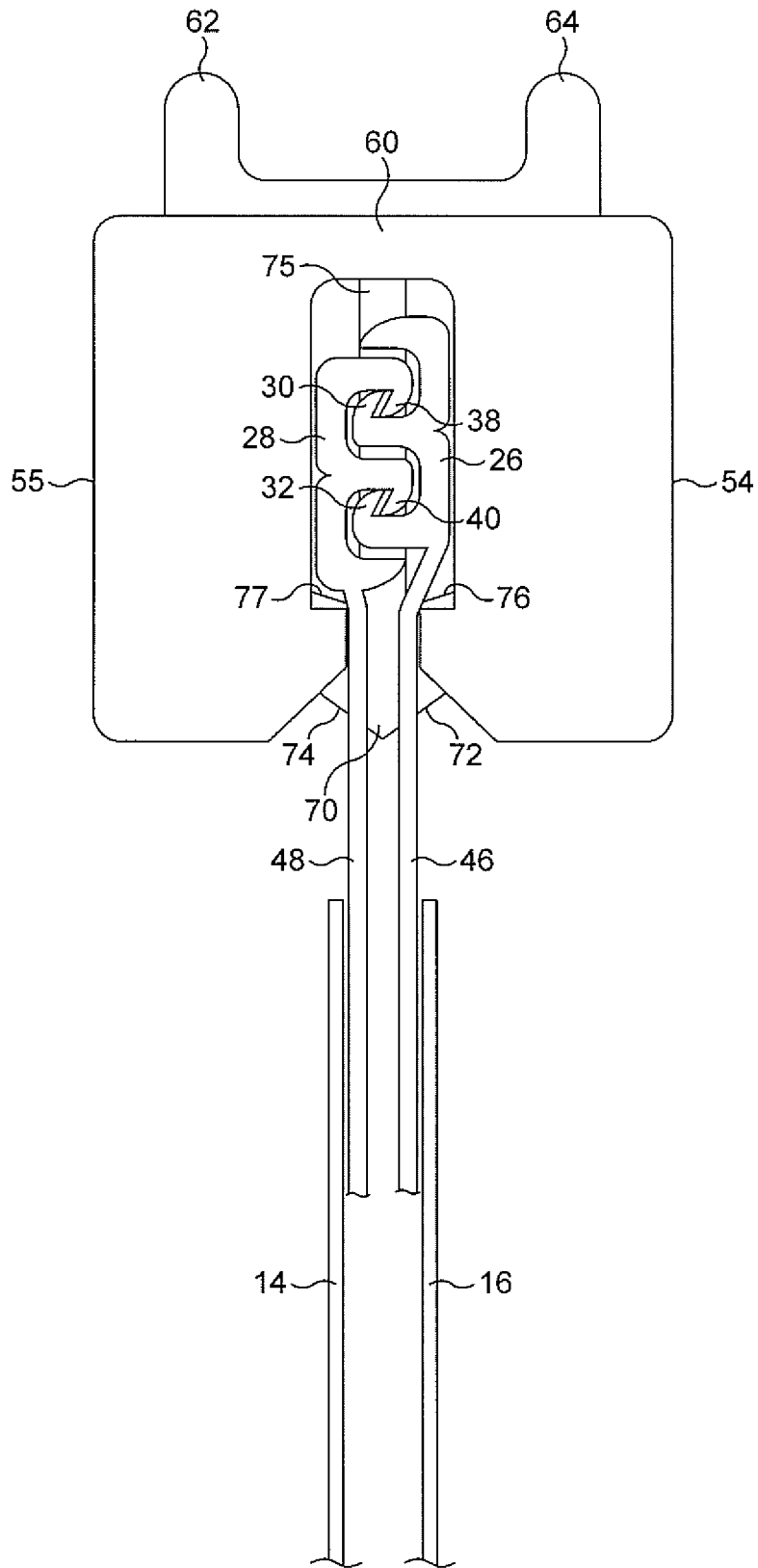

FIG. 12



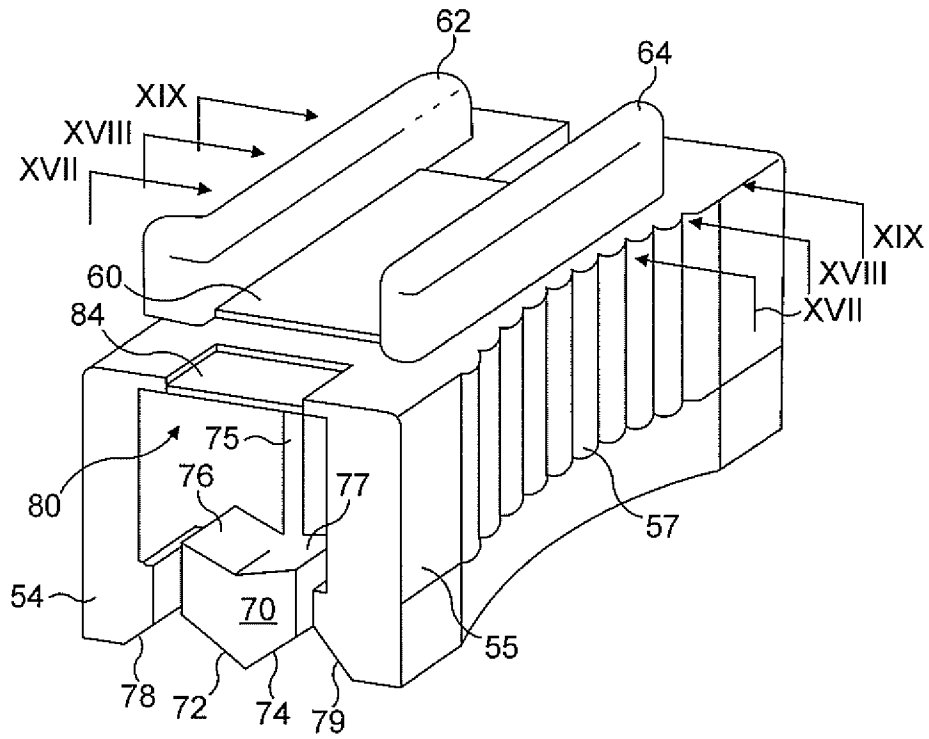

FIG. 13

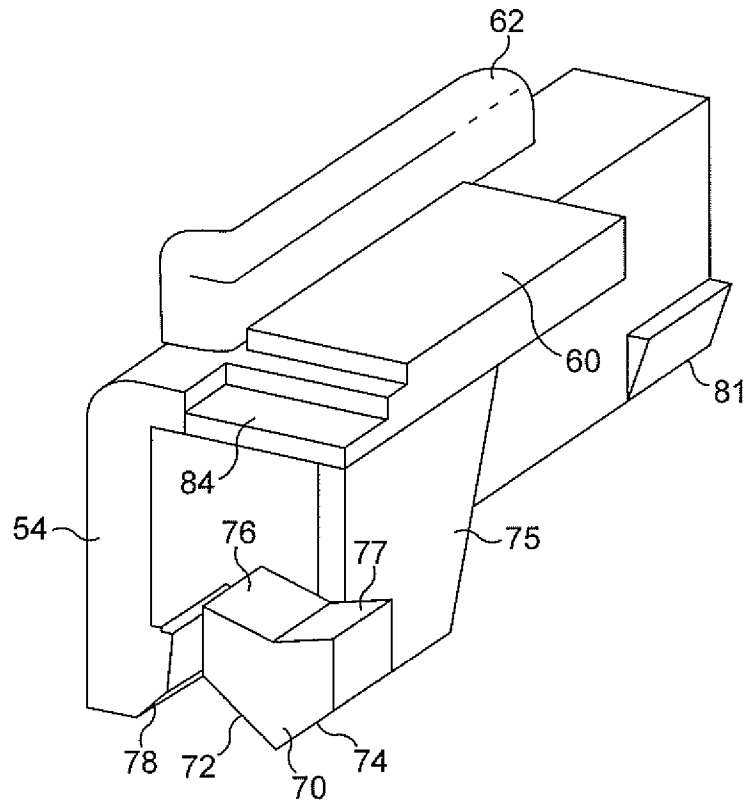

FIG. 14

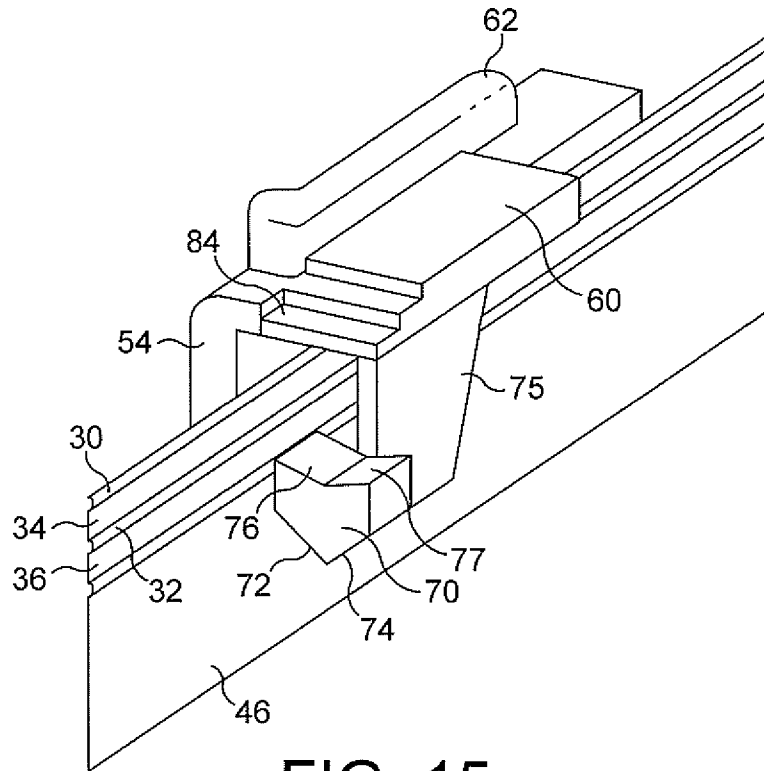

FIG. 15

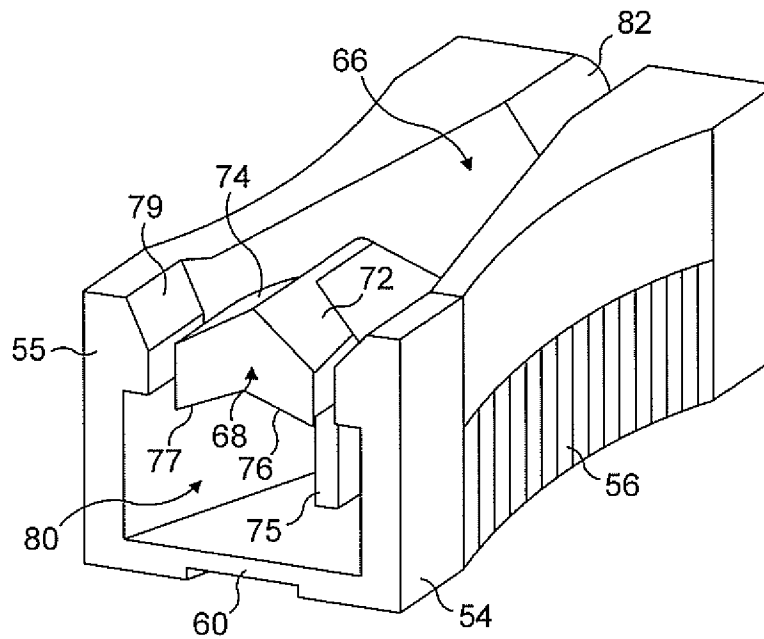

FIG. 16

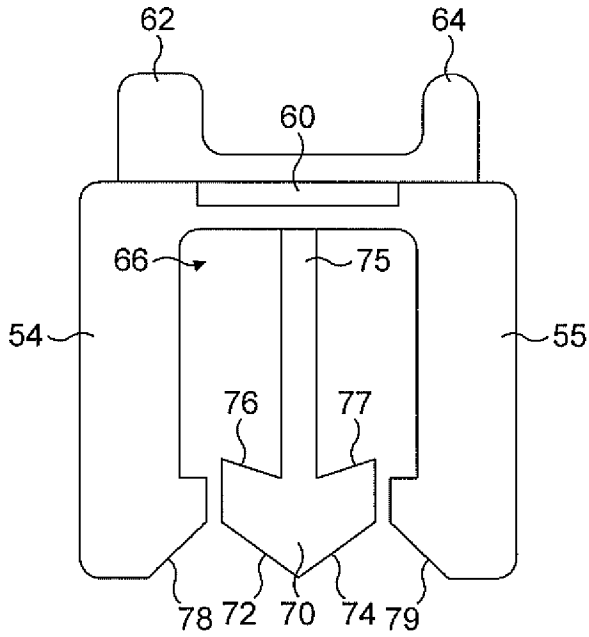

FIG. 17

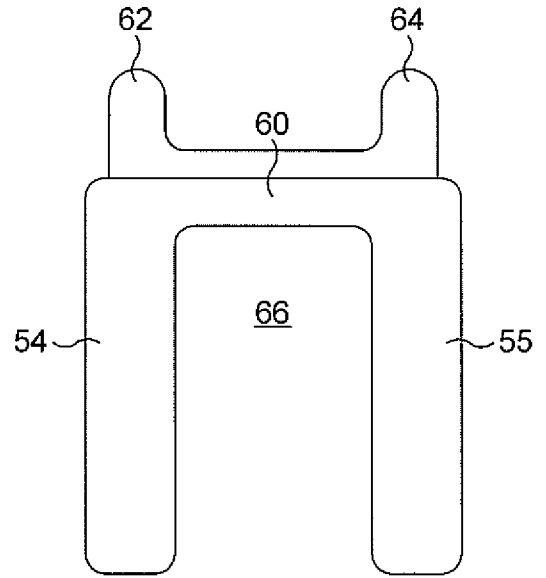

FIG. 18

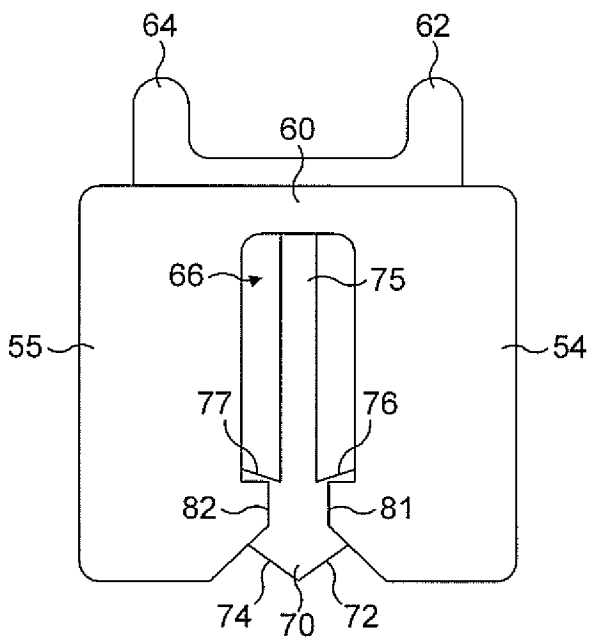

FIG. 19

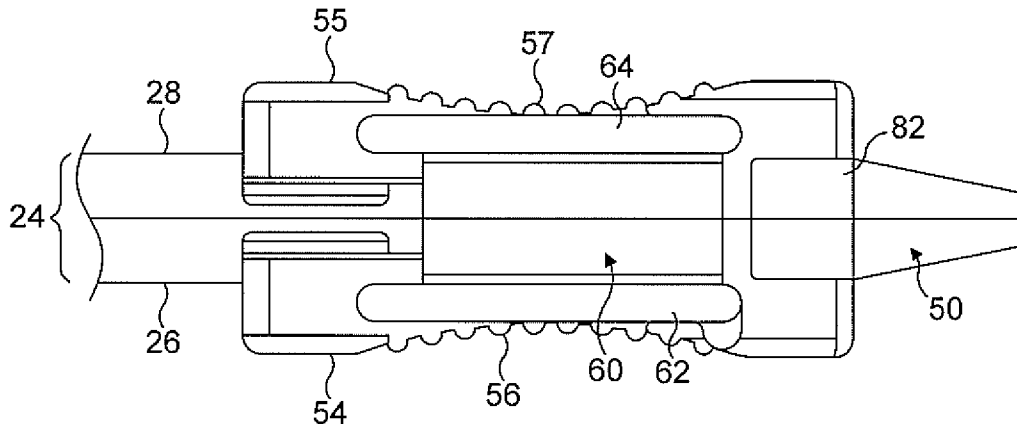

FIG. 20

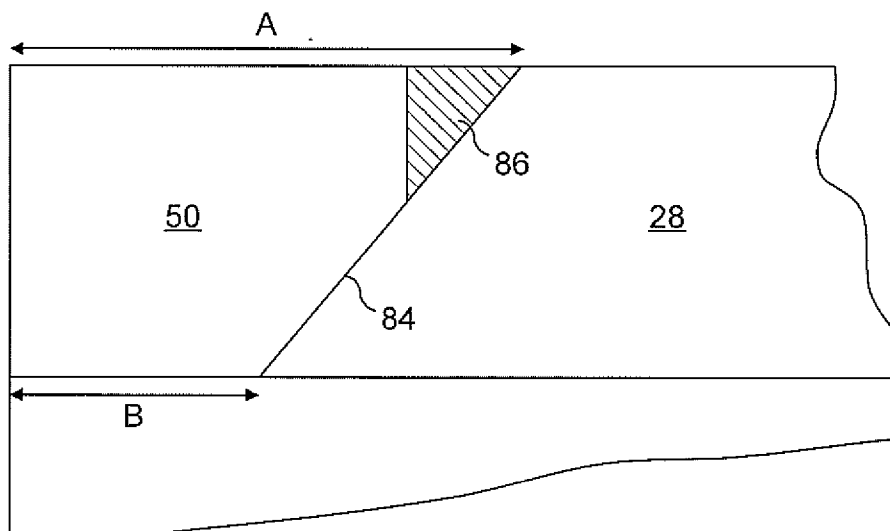

FIG. 21

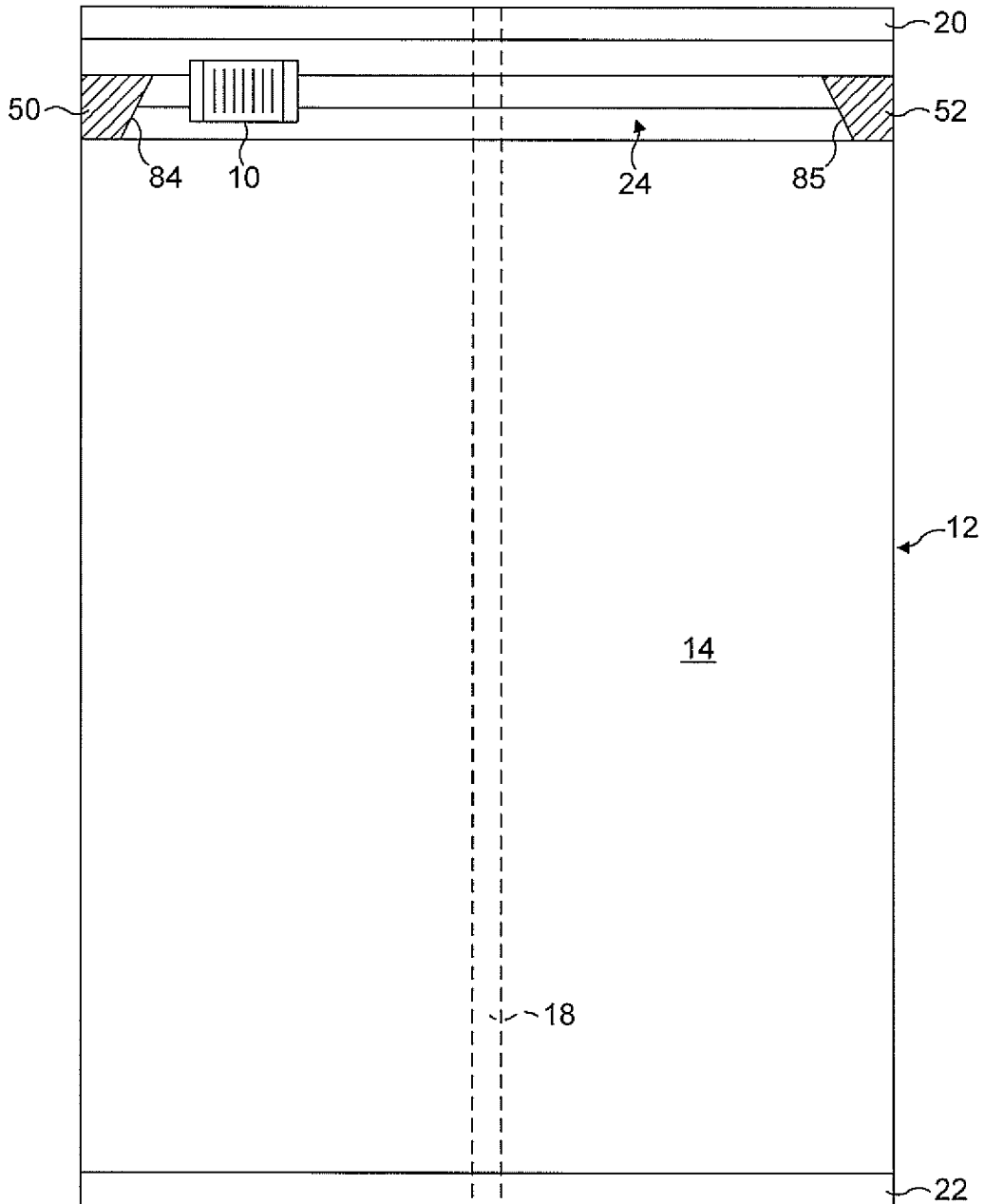

FIG. 22

16 / 19

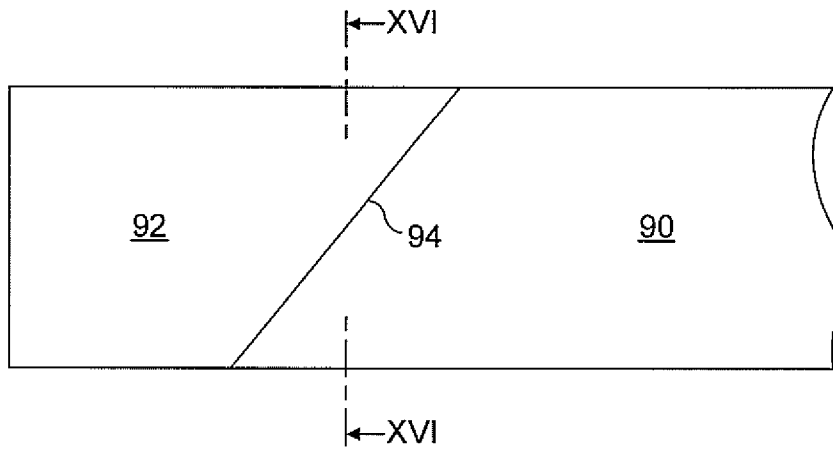

FIG. 23

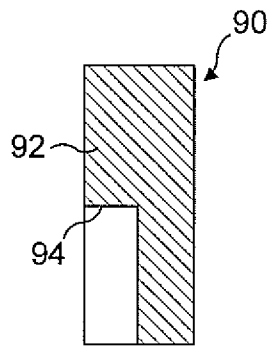

FIG. 24

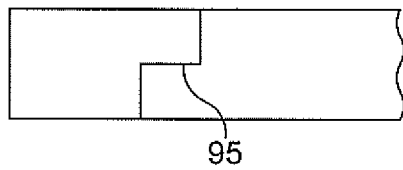

FIG. 25

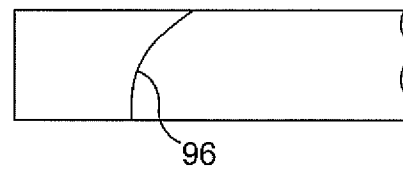

FIG. 26

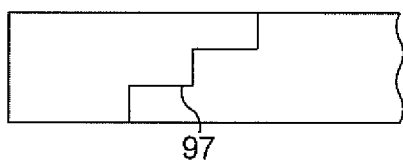

FIG. 27

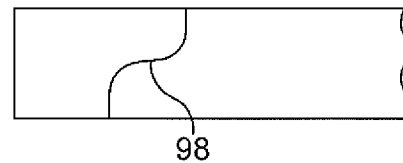

FIG. 28

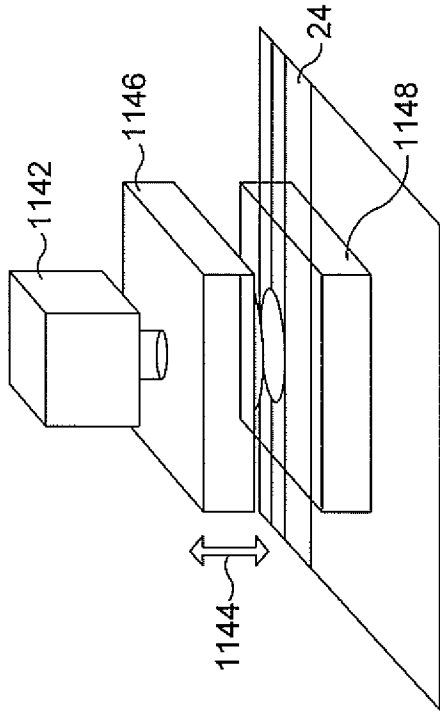

FIG. 29B

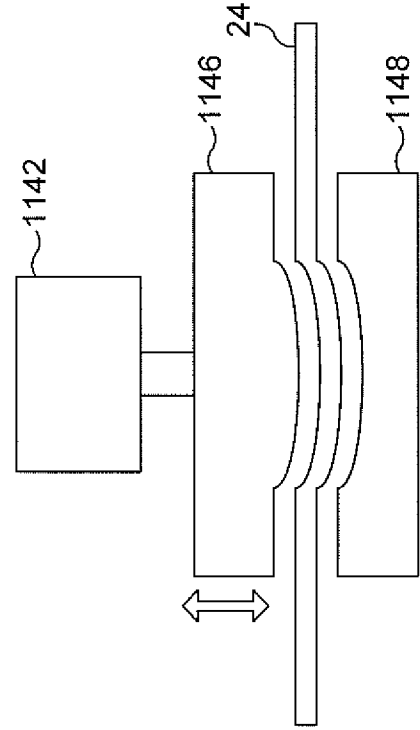

FIG. 30B

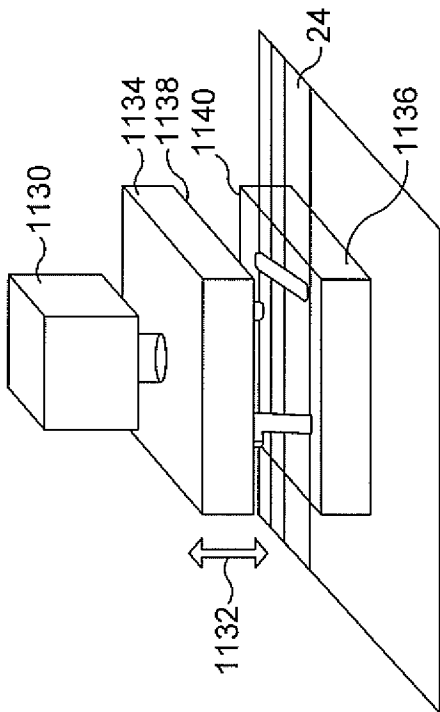

FIG. 29A

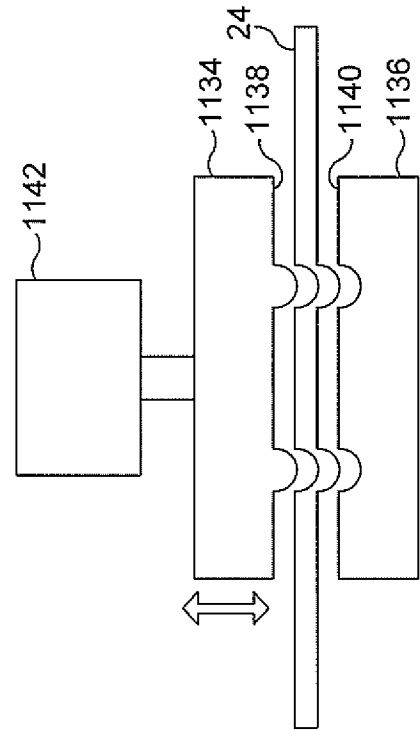

FIG. 30A

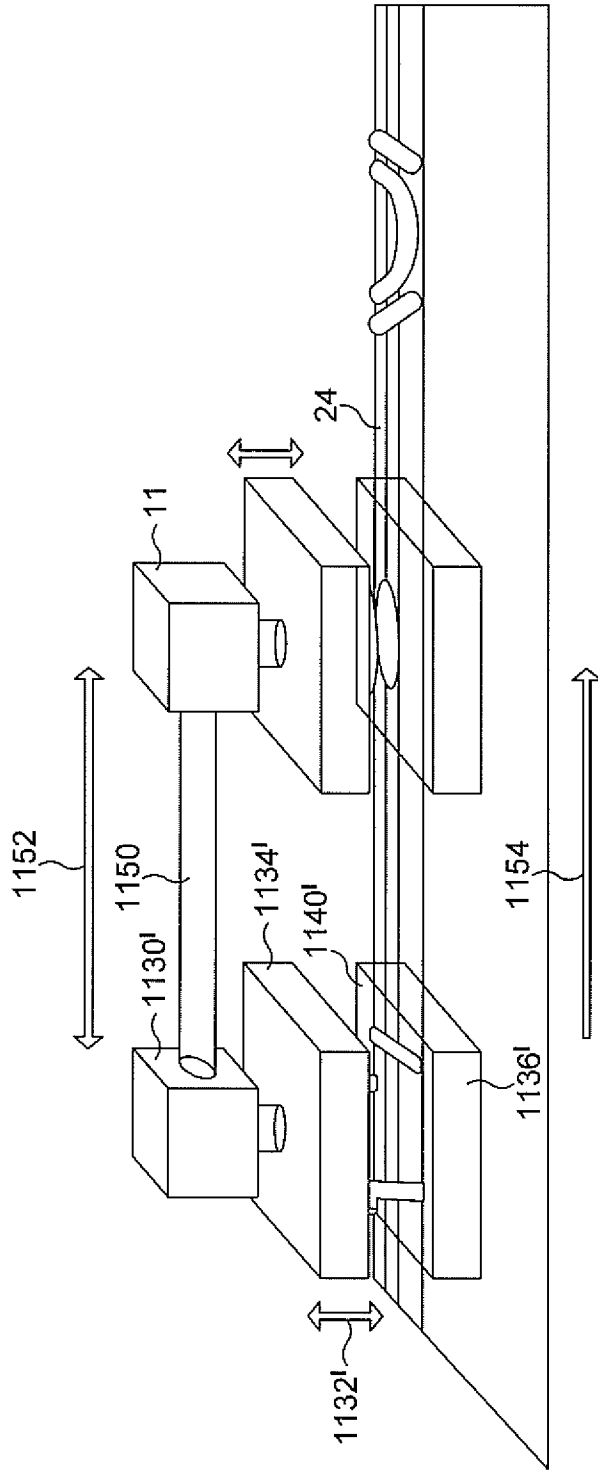

FIG. 31

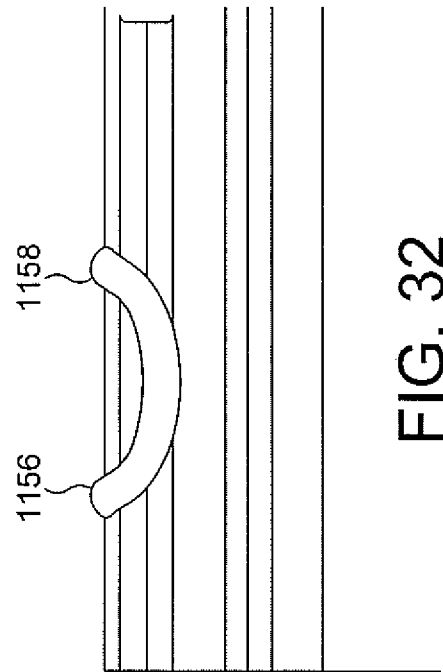

FIG. 32

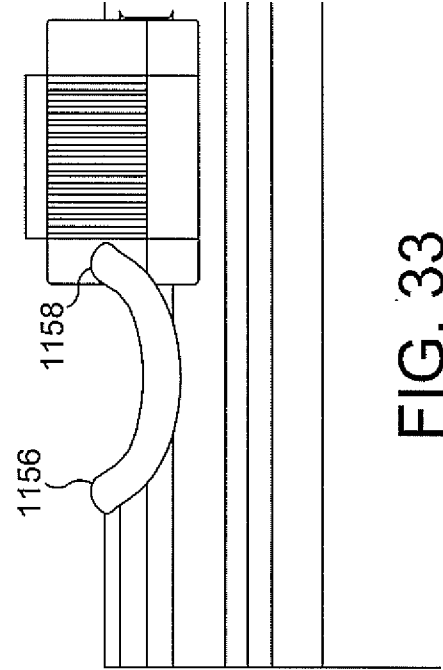

FIG. 33



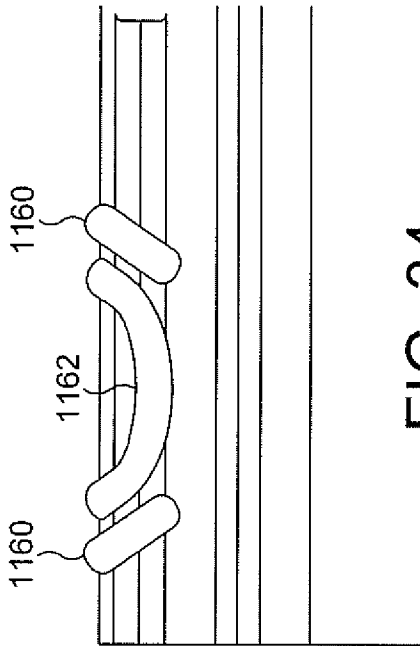

FIG. 34

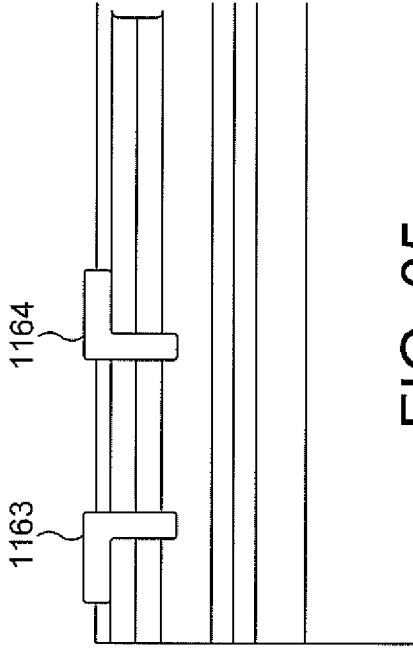

FIG. 35

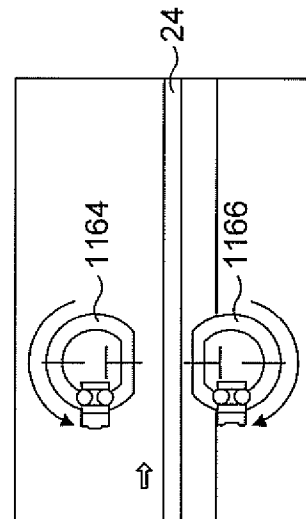

FIG. 36

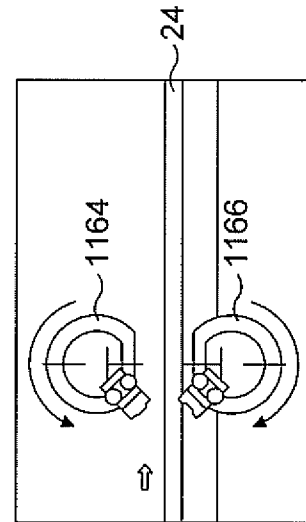

FIG. 37

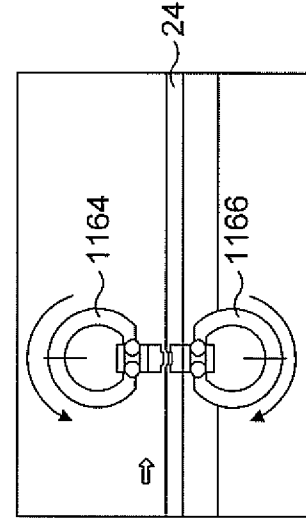

FIG. 38

**INTERNATIONAL SEARCH REPORT**

International application No  
**PCT/GB2010/050238**

<b>A. CLASSIFICATION OF SUBJECT MATTER</b> INV. B65D33/25 ADD.		
According to International Patent Classification (IPC) or to both national classification and IPC		
<b>B. FIELDS SEARCHED</b>		
Minimum documentation searched (classification system followed by classification symbols) <b>B65D</b>		
Documentation searched other than minimum documentation to the extent that such documents are included in the fields searched		
Electronic data base consulted during the international search (name of data base and, where practical, search terms used) <b>EPO-Internal</b>		
<b>C. DOCUMENTS CONSIDERED TO BE RELEVANT</b>		
Category*	Citation of document, with indication, where appropriate, of the relevant passages	Relevant to claim No.
X	EP 1 391 390 A1 (REYNOLDS CONSUMER PROD [US]) 25 February 2004 (2004-02-25)	1, 3, 9-15, 22-25, 49, 52
Y	figures 2, 7B	4, 6-8, 16, 18, 20, 26, 34-48, 50, 51
X	----- WO 00/76352 A1 (GLAD PRODUCTS CO [US]; BORCHARDT MICHAEL G [US]; SAVICKI ALAN F SR [US]) 21 December 2000 (2000-12-21)	27, 28, 32, 33, 53
Y	figures 3, 4, 15, 16  ----- -/--	16, 18, 29, 30
<input checked="" type="checkbox"/> Further documents are listed in the continuation of Box C. <span style="margin-left: 200px;"><input checked="" type="checkbox"/> See patent family annex.</span>		
* Special categories of cited documents :		
"A" document defining the general state of the art which is not considered to be of particular relevance "E" earlier document but published on or after the international filing date "L" document which may throw doubts on priority claim(s) or which is cited to establish the publication date of another citation or other special reason (as specified) "O" document referring to an oral disclosure, use, exhibition or other means "P" document published prior to the international filing date but later than the priority date claimed		"T" later document published after the international filing date or priority date and not in conflict with the application but cited to understand the principle or theory underlying the invention "X" document of particular relevance; the claimed invention cannot be considered novel or cannot be considered to involve an inventive step when the document is taken alone "Y" document of particular relevance; the claimed invention cannot be considered to involve an inventive step when the document is combined with one or more other such documents, such combination being obvious to a person skilled in the art. "&" document member of the same patent family
Date of the actual completion of the international search	Date of mailing of the international search report	
<b>10 May 2010</b>	<b>19/05/2010</b>	
Name and mailing address of the ISA/ European Patent Office, P.B. 5818 Patentlaan 2 NL - 2280 HV Rijswijk Tel. (+31-70) 340-2040, Fax: (+31-70) 340-3016	Authorized officer  <b>Bridault, Alain</b>	

## INTERNATIONAL SEARCH REPORT

International application No  
PCT/GB2010/050238

C(Continuation). DOCUMENTS CONSIDERED TO BE RELEVANT		
Category*	Citation of document, with indication, where appropriate, of the relevant passages	Relevant to claim No.
X A	FR 2 915 966 A1 (S2F FLEXICO SARL [FR]) 14 November 2008 (2008-11-14) page 6, line 5 - line 7 page 8, line 10 - line 14; figures 3, 9 -----	27,28, 32,33 14-16
Y	EP 1 709 883 A1 (S2F FLEXICO [FR]) 11 October 2006 (2006-10-11) figure 3 -----	4,6,7,26
Y	EP 1 447 338 A1 (ILLINOIS TOOL WORKS [US]) 18 August 2004 (2004-08-18) figure 5 -----	8
Y	US 6 364 530 B1 (BUCHMAN JAMES E [US]) 2 April 2002 (2002-04-02) figure 1 -----	20
Y	WO 00/67603 A1 (PACTIV CORP [US]) 16 November 2000 (2000-11-16) page 8, line 3 - page 9, line 4; figures 1, 4, 6 -----	29,30, 34-47
L	US 5 442 837 A (MORGAN KEVIN P [US]) 22 August 1995 (1995-08-22) figure 1 -----	34-47
Y	US 4 909 017 A (MCMAHON MICHAEL J [US] ET AL) 20 March 1990 (1990-03-20) cited in the application figure 1 -----	43,48, 50,51

# INTERNATIONAL SEARCH REPORT

International application No.  
PCT/GB2010/050238

## Box No. II Observations where certain claims were found unsearchable (Continuation of item 2 of first sheet)

This international search report has not been established in respect of certain claims under Article 17(2)(a) for the following reasons:

1.  Claims Nos.:  
because they relate to subject matter not required to be searched by this Authority, namely:
  
2.  Claims Nos.: 54-57  
because they relate to parts of the international application that do not comply with the prescribed requirements to such an extent that no meaningful international search can be carried out, specifically:  
see FURTHER INFORMATION sheet PCT/ISA/210
  
3.  Claims Nos.:  
because they are dependent claims and are not drafted in accordance with the second and third sentences of Rule 6.4(a).

## Box No. III Observations where unity of invention is lacking (Continuation of item 3 of first sheet)

This International Searching Authority found multiple inventions in this international application, as follows:

1.  As all required additional search fees were timely paid by the applicant, this international search report covers all searchable claims.
  
2.  As all searchable claims could be searched without effort justifying an additional fees, this Authority did not invite payment of additional fees.
  
3.  As only some of the required additional search fees were timely paid by the applicant, this international search report covers only those claims for which fees were paid, specifically claims Nos.:
  
4.  No required additional search fees were timely paid by the applicant. Consequently, this international search report is restricted to the invention first mentioned in the claims; it is covered by claims Nos.:

### Remark on Protest

- The additional search fees were accompanied by the applicant's protest and, where applicable, the payment of a protest fee.
- The additional search fees were accompanied by the applicant's protest but the applicable protest fee was not paid within the time limit specified in the invitation.
- No protest accompanied the payment of additional search fees.

**FURTHER INFORMATION CONTINUED FROM PCT/ISA/ 210**

Continuation of Box II.2

Claims Nos.: 54-57

Claims 54-57 do not comply with Rule 6.2(a) PCT.

The applicant's attention is drawn to the fact that claims relating to inventions in respect of which no international search report has been established need not be the subject of an international preliminary examination (Rule 66.1(e) PCT). The applicant is advised that the EPO policy when acting as an International Preliminary Examining Authority is normally not to carry out a preliminary examination on matter which has not been searched. This is the case irrespective of whether or not the claims are amended following receipt of the search report or during any Chapter II procedure. If the application proceeds into the regional phase before the EPO, the applicant is reminded that a search may be carried out during examination before the EPO (see EPO Guideline C-VI, 8.2), should the problems which led to the Article 17(2) declaration be overcome.

## INTERNATIONAL SEARCH REPORT

Information on patent family members

International application No

PCT/GB2010/050238

Patent document cited in search report		Publication date	Patent family member(s)	Publication date
EP 1391390	A1	25-02-2004	US 2004037477 A1	26-02-2004
WO 0076352	A1	21-12-2000	AU 766321 B2 AU 4339999 A CA 2373792 A1 JP 2003501184 T	16-10-2003 02-01-2001 21-12-2000 14-01-2003
FR 2915966	A1	14-11-2008	NONE	
EP 1709883	A1	11-10-2006	FR 2884227 A1 JP 2006290464 A US 2006225256 A1	13-10-2006 26-10-2006 12-10-2006
EP 1447338	A1	18-08-2004	AU 2004200474 A1 BR PI0400907 A CA 2457593 A1 CL 2422004 A1 CL 2432004 A1 JP 4327621 B2 JP 2004244114 A MX PA04001440 A US 2004161168 A1 US 2004161169 A1 US 2004161170 A1 US 2004161171 A1 US 2004161172 A1 US 2004161167 A1	02-09-2004 11-01-2005 14-08-2004 04-03-2005 18-03-2005 09-09-2009 02-09-2004 19-08-2004 19-08-2004 19-08-2004 19-08-2004 19-08-2004 19-08-2004 19-08-2004
US 6364530	B1	02-04-2002	NONE	
WO 0067603	A1	16-11-2000	AT 322188 T AT 335422 T AT 356558 T AT 366526 T AU 4820000 A CA 2336693 A1 DE 60027125 T2 DE 60030015 T2 DE 60033978 T2 DE 60035535 T2 DE 60037289 T2 EP 1119268 A1 ES 2261203 T3 ES 2270250 T3 ES 2282944 T3 JP 2002543861 T	15-04-2006 15-09-2006 15-04-2007 15-08-2007 21-11-2000 16-11-2000 07-09-2006 11-01-2007 28-06-2007 25-10-2007 06-03-2008 01-08-2001 16-11-2006 01-04-2007 16-10-2007 24-12-2002
WO 0067603	A1		US 6286189 B1 US 2001002504 A1	11-09-2001 07-06-2001
US 5442837	A	22-08-1995	AT 207714 T AU 678717 B2 AU 2469695 A CA 2193078 A1 DE 69523599 D1 DE 69523599 T2 DK 771159 T3 EP 0771159 A1	15-11-2001 05-06-1997 15-01-1996 28-12-1995 06-12-2001 11-04-2002 10-12-2001 07-05-1997

# INTERNATIONAL SEARCH REPORT

Information on patent family members

International application No <b>PCT/GB2010/050238</b>
--

Patent document cited in search report	Publication date	Patent family member(s)	Publication date
		ES 2168365 T3	16-06-2002
		JP 2937482 B2	23-08-1999
		JP 10503672 T	07-04-1998
		PT 771159 E	29-04-2002
		WO 9535048 A1	28-12-1995
US 4909017	A	20-03-1990	
		AU 621493 B2	12-03-1992
		AU 5684890 A	31-01-1991
		CA 2018436 A1	28-01-1991
		EP 0410126 A1	30-01-1991
		JP 3069410 A	25-03-1991
		NZ 233976 A	26-11-1991