

(No Model.)

J. M. WELLS. FILTER.

No. 538,360.

Patented Apr. 30, 1895.

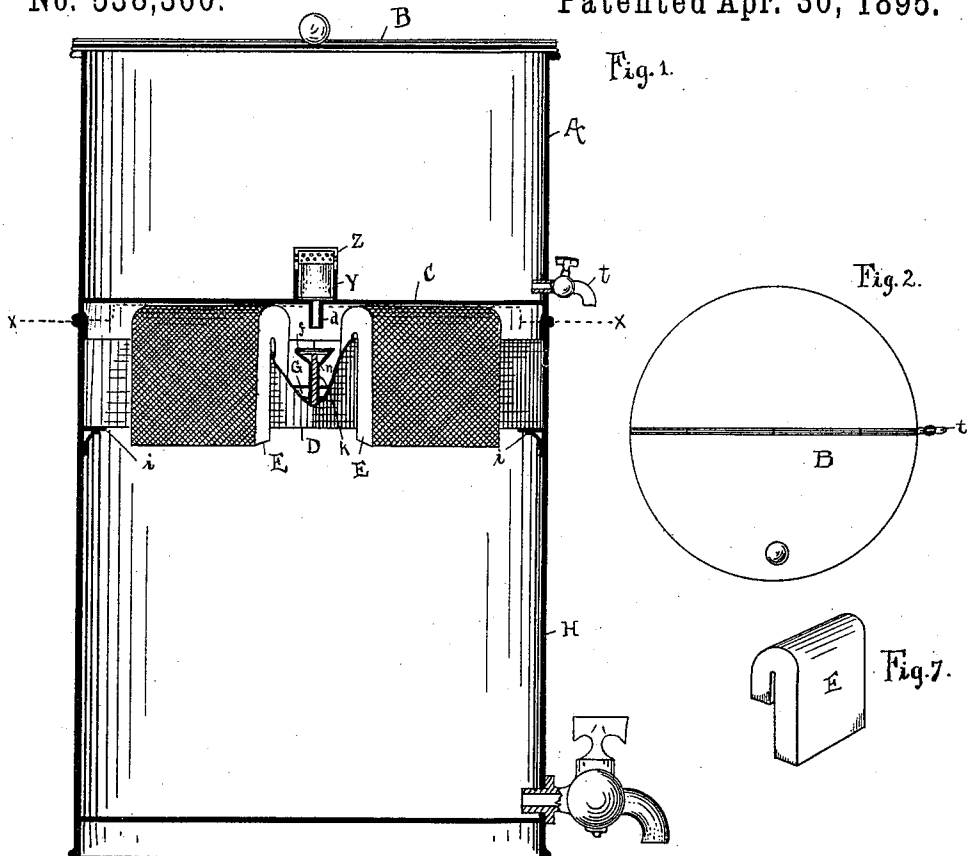

Fig. 1.

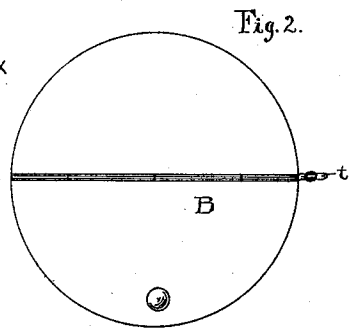

Fig. 2.

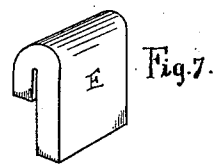

Fig. 7.

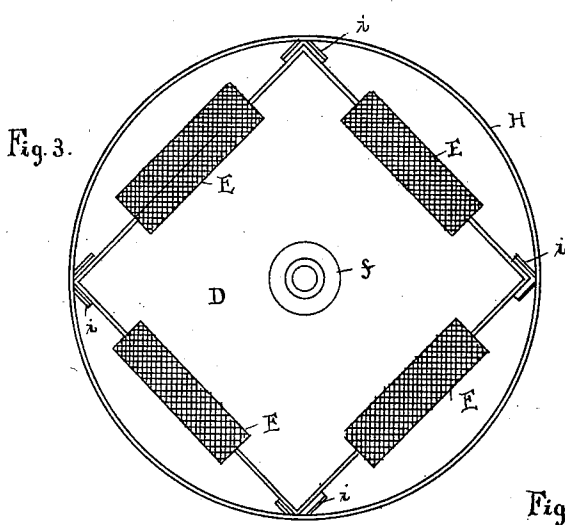

Fig. 3.

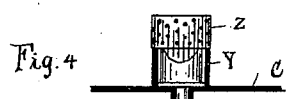

Fig. 4.

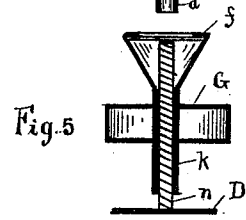

Fig. 5.

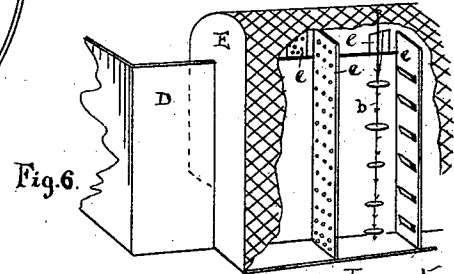

Fig. 6.

Witnesses
Minnie Haley
Amos Dixon

Inventor
James M. Wells
 By *W. T. Deft* atty

UNITED STATES PATENT OFFICE.

JAMES M. WELLS, OF PEORIA, ILLINOIS.

FILTER.

SPECIFICATION forming part of Letters Patent No. 538,360, dated April 30, 1895.

Application filed June 21, 1894. Serial No. 515,257. (No model.)

To all whom it may concern:

Be it known that I, JAMES M. WELLS, a citizen of the United States, residing at Peoria, in the county of Peoria and State of Illinois, have invented certain new and useful Improvements in Filters; and I do hereby declare that the following is a full, clear, and exact description of the invention, which will enable others skilled in the art to which it appertains to make and use the same.

My invention relates to certain new and useful improvements in filters, by means of which a filter is provided being simple in construction, effective in operation, durable and cheap in first cost.

More particularly my invention relates to a filter, designed to perform its office through the action of capillary attraction, acting through the absorbent material carried within cases in suitable form to be carried over the sides of a vat, one end of each depending within and being submerged in the liquid therein contained, and depending without the said vat.

My invention consists essentially of the general construction and form of the combined elements employed in the operative devices of the case containing the absorbent material, and the automatic arrangement for controlling the flow of oil within the filter, and of various other details of construction hereinafter more particularly mentioned.

That my invention may be more fully understood, reference may be had to the accompanying drawings, in which—

Figure 1 is a sectional view of the general frame structure of the filter, showing the location of the several parts thereof, and showing a portion of a vat contained in the structure broken away. Fig. 2 is a plan view, showing the hinged top. Fig. 3 is a sectional view through line *x, x*, Fig. 1, and shows a plan view of the vat, its manner of support, and also shows the cases in their adjustment upon the sides thereof. Fig. 4 is a detailed view, showing the exit opening in the bottom of the top compartment of the filter, and also a perforated cap in connection therewith. Fig. 5 is a detailed view, showing a float in connection with a valve purposed to close the opening or spout leading into the upper compartment above the vat, and the manner of carrying the

said float is also shown in this figure. Fig. 6 is a detailed view of a case, designed to be filled with absorbent material, and shows the particular internal construction thereof. Fig. 7 is a detailed view of a case, the same as Fig. 6, except that its sides are entirely closed and no internal partitions or other absorbent supports are provided in connection therewith.

In the figures, H refers to a circular receptacle or tank provided with a suitable faucet at its lower portion, provided that liquid may be drawn from the tank or reservoir. Surmounting the frame structure H, is the compartment A, which is provided with the bottom C, and lid or cover B, which is hinged in the manner shown, which said compartment bears within a rim provided at the upper edge of the compartment H, and effectually closes said compartment at its top. Within the compartment H and immediately below or at a suitable distance below the compartment A, there is provided the vat D supported upon the lugs *i*, and is designed to contain the oil or liquid, flowing from the compartment above.

At the central portion of the bottom C, there is provided the cup Y, suitably connected with the bottom C, and being surmounted or bearing at its top portion the perforated cap Z, which said perforated cap may be substituted by or covered over with a suitable screen material. Depending below and connected with an opening in the bottom C, there is provided the spout or duct *d*, thus providing for the flow of oil or other liquid from the compartment A into the vat D below the screen material or perforated cap surmounting cup Z preventing the entrance therein of any foreign matter or large piece of sediment, and by the said cap being carried upon the top of the said cup, and at a considerable distance above the bottom C of the said vat, any water mingled with the oil poured into the compartment A, will separate from the oil naturally, by gravitating downwardly, preventing its flow into the vat and compartment below, and the accumulation of water may readily be withdrawn from the said lower portion of the compartment A, through the faucet *t*.

G is a buoy made of light material that will float upon the surface of the oil within the

vat D, and is provided with the depending sleeve *k* carried around the perpendicular rod *n* connected with the bottom of the said vat and free to move upwardly and downwardly thereon, as the float is carried in a higher or lower position in the said vat upon the surface of the liquid, and the said buoy has connected with the top portion thereof, the valve *f* designed to close the mouth of the depending spout *d*, to stop the flow of oil or liquid from the compartment A above; which said valve is designed to present a leather, rubber or other suitable bearing surface for contact with the said spout *d*.

The buoy G is made light and of sufficient size, that it may displace enough liquid to give it a strong upward pressure to insure the closing of the spout *d*, to absolutely prevent the flow of oil therethrough when the vat D is filled to the desired height, thus providing an automatic means for preventing an excessive flow of the oil or liquid from in the compartment above into the vat below.

In connection with Fig. 1, there are shown the cases E in which said figure, the cases are shown to be constructed with solid sides and covered with wire netting, and in such a form as to produce practically a siphon shape with the short end of the said siphon or case bearing within the vat D, and the long portions thereof bearing without the said vat, but this particular and peculiar construction, it is not necessary to follow strictly to obtain the results desired, as the cases may be of different forms, and instead of being covered with wire netting may be made with perfectly solid sides, as shown in Fig. 7, or the cases may be constructed of suitable metal as tin or sheet iron, and be perforated in a suitable manner to admit the entrance of air and liquid therethrough and into the said case.

The cases E are purposed to be filled with cotton batting or any other suitable absorbent material, packed, laid or folded therein in any suitable manner, so that the said filling or the parts or particles thereof will assume the proper relation to accommodate the carrying out of the principle of operation as designed. The cases being so filled being purposed to be carried over the sides of the said vat in the manner previously explained. To assist in the proper packing of the said cases with certain kinds of filtering material, the perpendicular partitions *e*, (shown in Fig. 6) may be employed, the same extending from the lower edge of the respective sides of the case and continuing upwardly nearly to the top thereof, which said partitions may be perforated as shown to present rough edges, or lips may be struck out from the said partitions as shown, and they may further be provided with the depending rods *b*, detachably connected at the upper portion of the case and in such position as to depend between the respective partitions (one of such said rods being shown in the drawings), said rods *b* being slivered to open outwardly to provide

for the engagement of washers, that may be slipped upon the rods and held in the desired position thereby the said rod, being capable of withdrawal from the washers by being first detached from the case, as will readily be seen.

In operation for the purpose designed, namely, for filtering liquid, the compartment A is filled with oil or other liquid or any desired quantity may be placed therein, it of course being necessary that there shall be a sufficient supply to submerge the cap Z upon the cup Y, when the said liquid will pass through the perforations in the said cap into the cup, and escape downwardly through the opening in the bottom C through the tube *d* and flow into the vat D, which flow will continue gradually filling the said vat, the surface of the liquid therein bearing gradually upwardly the buoy G, such flow into the vat continuing until the said buoy G shall have been carried upwardly a sufficient distance to cause the valve *f* to bear over the mouth of the spout *d* to close the same, and will be brought in such close and firm contact with the mouth of the said spout as to effectually shut off the flow of liquid through the spout *d*, and from the compartment above, this buoy and valve being provided so that the vat, at no time, will be filled to overflowing.

The cases E carried over the edge of the vat D depend a sufficient distance within the said vat that a portion thereof or one end of each will be submerged in the oil or liquid within the vat, and the absorbent material therein will quickly be saturated, and by capillary attraction will be conducted upwardly within the said cases, over the top of the vat and downwardly within and through the absorbent material in the parts of the case bearing without the said vat, and will drop downwardly from the ends of the said outside cases into the receptacle below, this flow continuing through the absorbent material in the case in a very rapid manner, and so long as the ends of the case bearing within the vat are submerged.

All sediment and foreign matter other than liquid will be prevented from passing through the case, as nothing but liquid will pass above the surface of the liquid within the vat, as only liquid can be conducted through the capillaries of the absorbent material. In this manner the oil or liquid is conducted into the compartment below in a perfectly pure state and may be drawn from the lower compartment as it may be needed for use.

Having thus fully described my invention, what I claim, and desire to secure by Letters Patent, is—

1. In a filter, the combination with a vat, containing liquid, of the case E, having the siphon form, and with the outer surface thereof formed of wire netting, and its end pieces of sheet metal, and provided with the partitions *e*, presenting rough surfaces, and having the barbed rod *b*, detachably connected with the upper portion of the said case, and de-

pending between the partitions and carrying the washers designed to be slipped upon the said rod, whereby, the absorbent material may be packed therein and held in proper
5 position, all substantially as described and shown.

2. A filter, consisting of the tank or receptacle A, divided into compartments by means of partition G, the upper compartment provided with cup Y surmounted by the perforated cap Z, and having the spout *d* connected with an opening in the bottom of the said partition, the vat D, suitably supported within the tank A, and provided with the valve for
15 stopping the flow of liquid from the upper compartment, consisting of the float G, vertically movable upon rod *n* projecting upwardly from the bottom of the vat and the cup *f* provided with a flat surface in the top portion

thereof of leather or other suitable material, 20
for bearing over the opening in the outlet spout *d* from the compartment above, and the cases E, having the siphon form and the outer surfaces thereof formed of wire netting and their end pieces of sheet metal and provided 25
with the partitions as *e* presenting rough surfaces and having the bars or rods as *d* detachably connected with the upper portions of the said cases and depending between the partitions and carrying the washers designed to be 30
slipped upon the said rods, all substantially as described and shown.

In testimony whereof I affix my signature in presence of two witnesses.

JAMES M. WELLS.

Witnesses:

W. V. TEFFT,
MINNIE HALEY.