



(19) **United States**

(12) **Patent Application Publication** (10) **Pub. No.: US 2004/0194859 A1**

**Asou et al.**

(43) **Pub. Date:**

**Oct. 7, 2004**

(54) **BLACK HEXAVALENT CHROMIUM-FREE PLATING TREATMENT SYSTEM**

(52) **U.S. Cl.** ..... 148/265

(76) Inventors: **Yoshitaka Asou, Ayabe (JP); Yasuhiro Shikata, Ayabe (JP); Toshio Shikata, Ayabe (JP); Ryuichi Fujiwara, Ayabe (JP)**

(57) **ABSTRACT**

The present invention provides a black hexavalent chromium-free plating treatment system in which the corrosion resistance of a surface of a metal part is improved by activating the surface of a zinc-plated coating of the metal part in a treatment solution in a dilute nitric acid activation treatment step, subsequently forming a black coating in an inorganic salt solution containing trivalent chromium and iron components as main ingredients in a black chromate treatment step, forming a conversion coating in a solution of inorganic salt and organic acid containing trivalent chromium and silica as main ingredients in a finish treatment step, and drying the resulting metal part. Therefore, even in a black trivalent chromate coating, sufficient corrosion resistance and sufficient strength are obtained. Moreover, a black trivalent chromate coating with heavy feeling is obtained for the first time. In addition, because the coating is one which is made mainly of trivalent chromium, less penetration into the ground occurs and the probability of occurrence of soil pollution caused by penetration of harmful substances into the ground is reduced.

Correspondence Address:  
**Naoki Nishimura**  
**NITTO SEIKO CO., LTD.**  
**Intellectual Property Section**  
**20 Umegahata, Inokura**  
**Ayabe Kyoto 623-0054 (JP)**

(21) Appl. No.: **10/783,680**

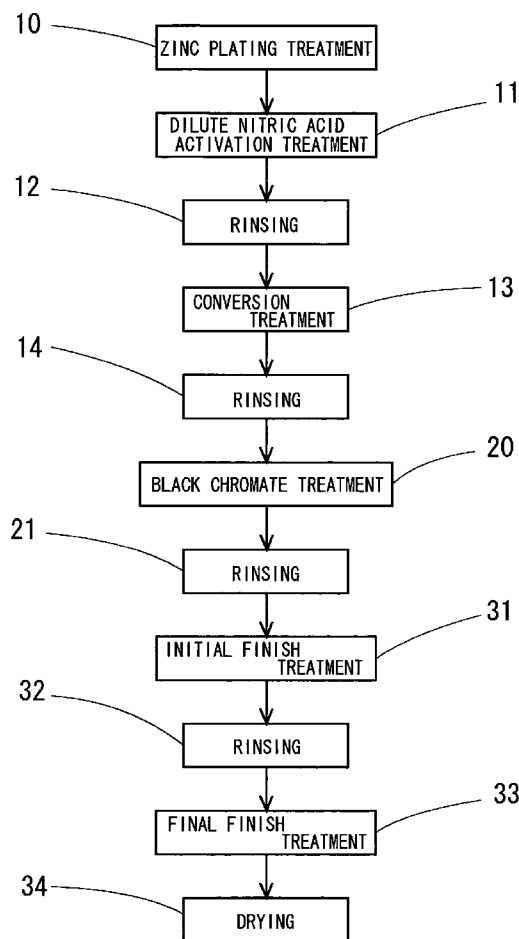
(22) Filed: **Feb. 20, 2004**

(30) **Foreign Application Priority Data**

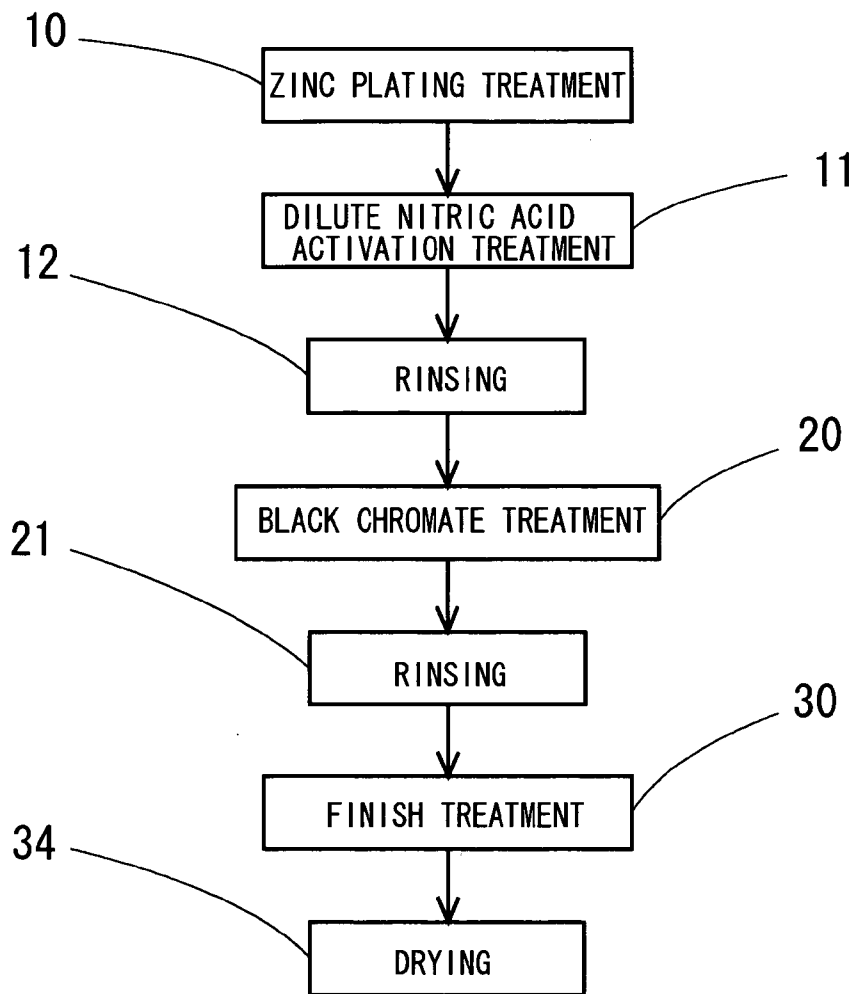
Feb. 28, 2003 (JP) ..... P2003-54221

**Publication Classification**

(51) **Int. Cl.<sup>7</sup>** ..... **C23C 22/82**

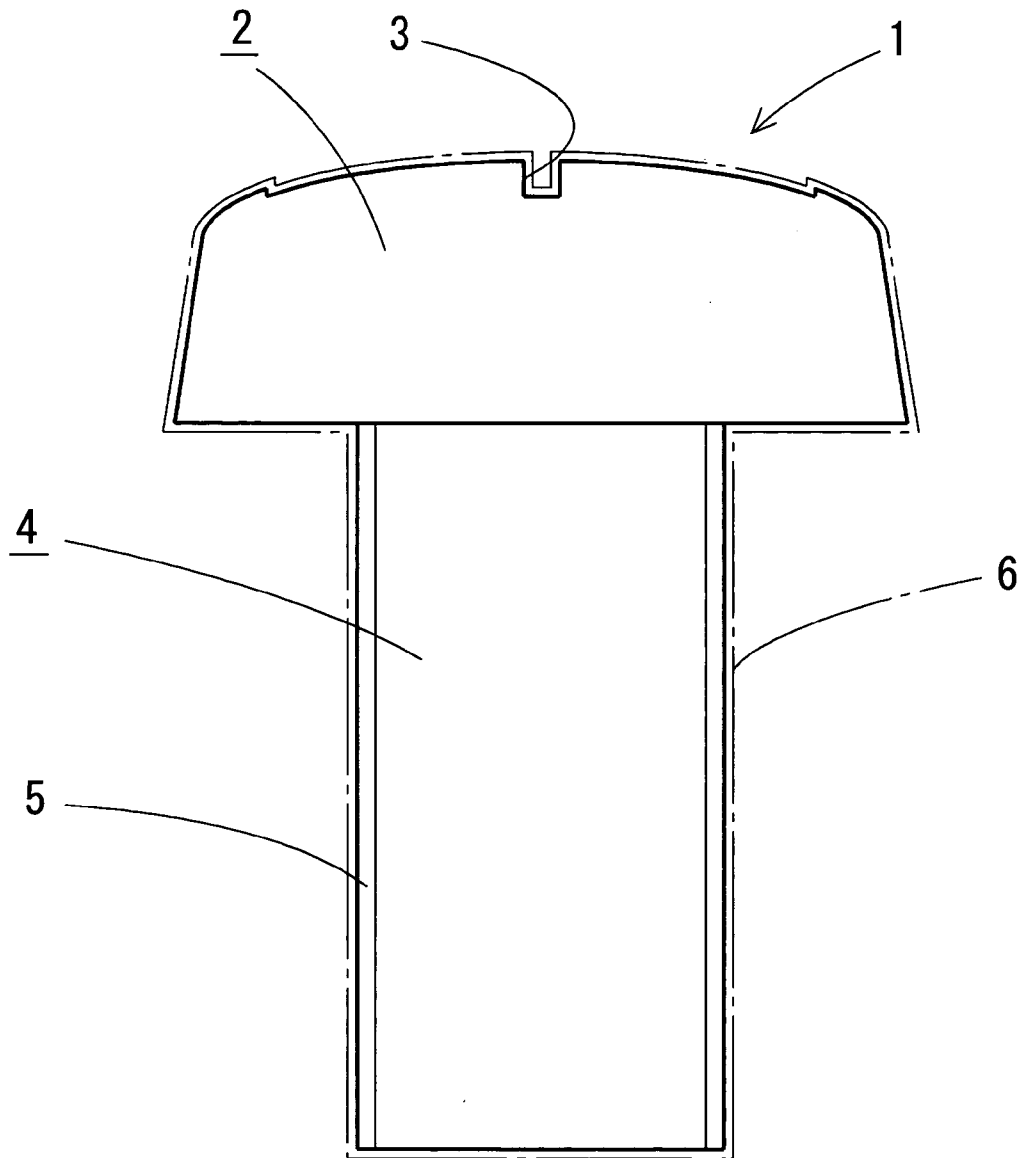


**Fig. 1**

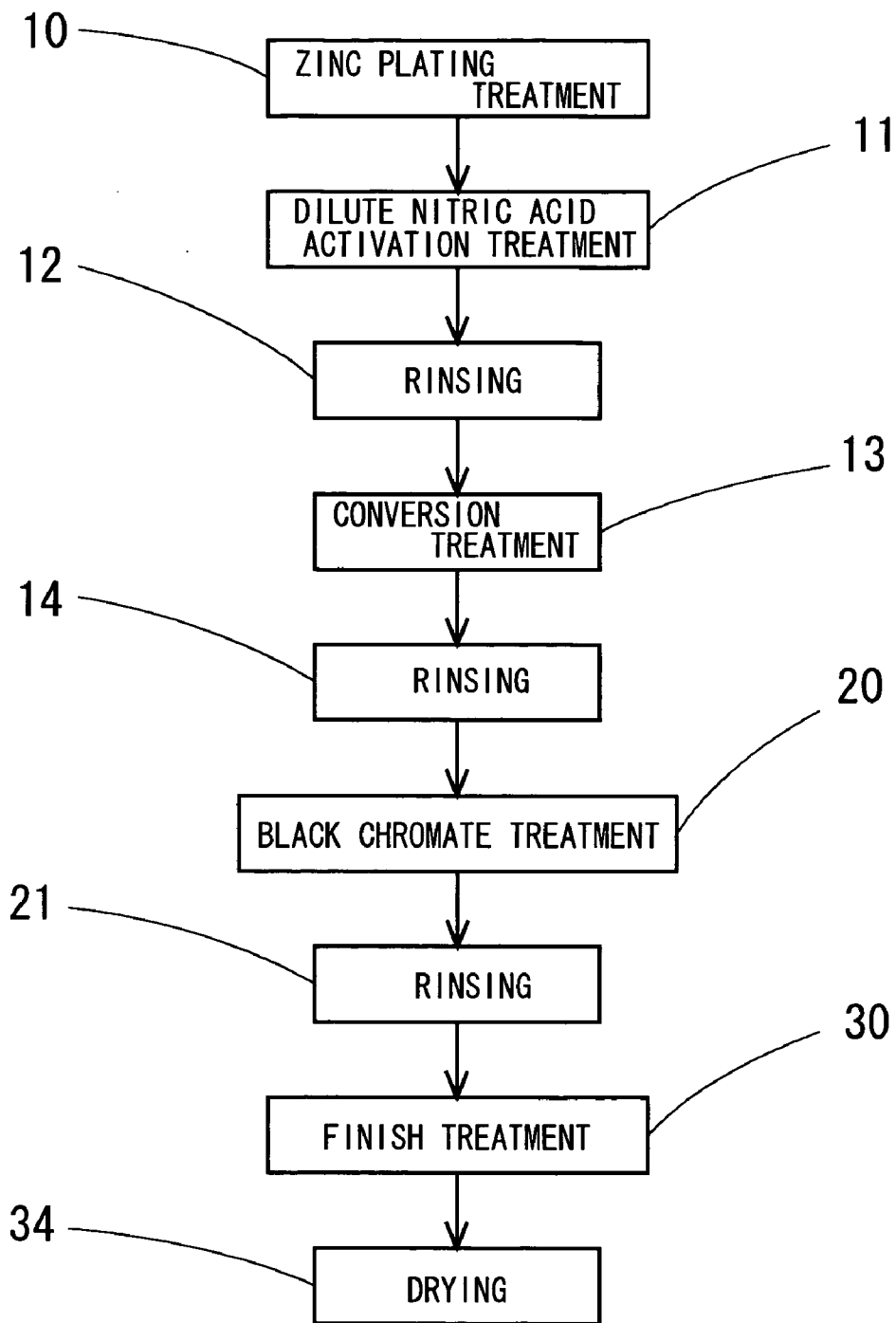


11: DILUTE NITRIC ACID ACTIVATION TREATMENT STEP  
20: BLACK CHROMATE TREATMENT STEP  
30: FINISH TREATMENT STEP

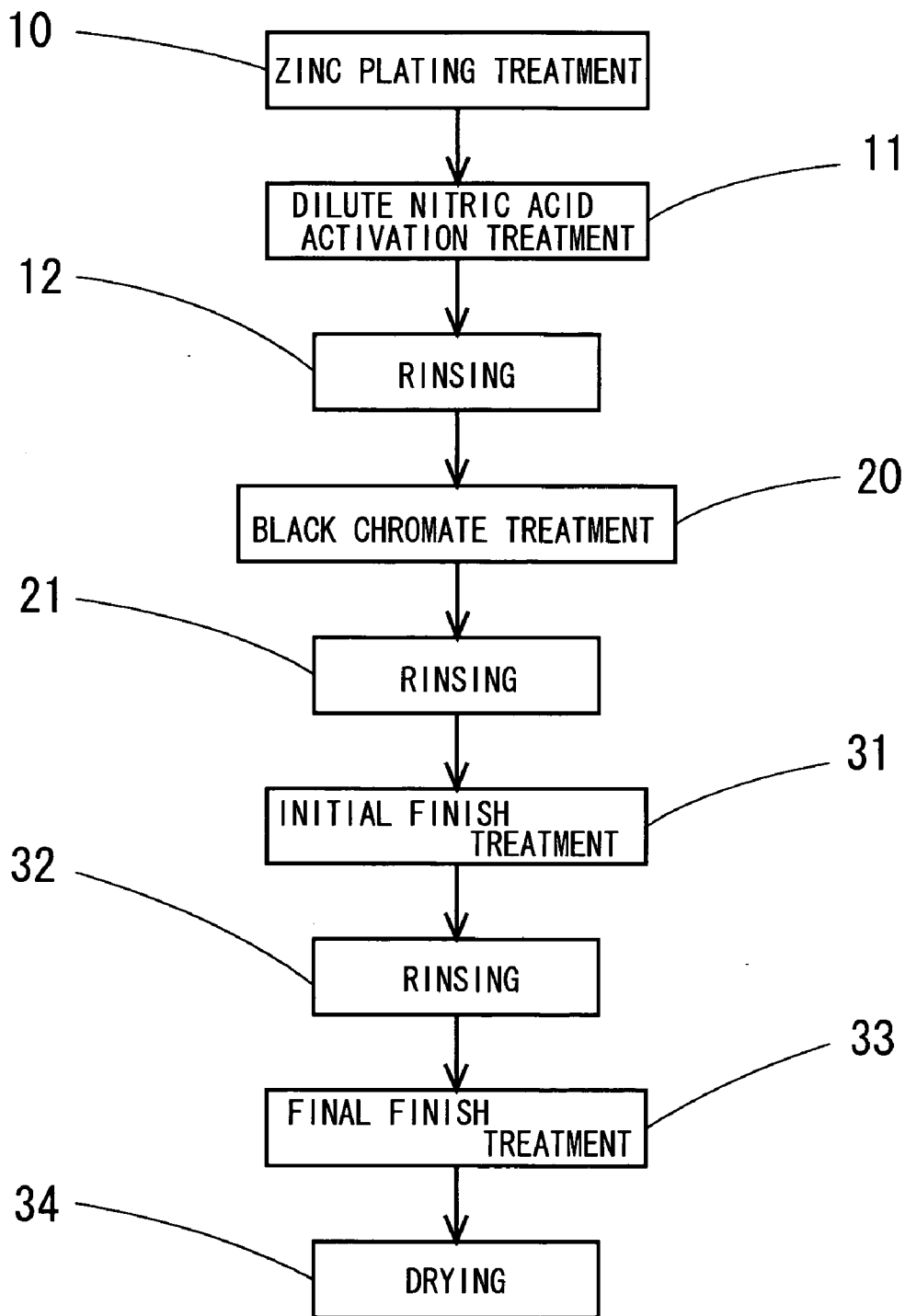
**Fig. 2**



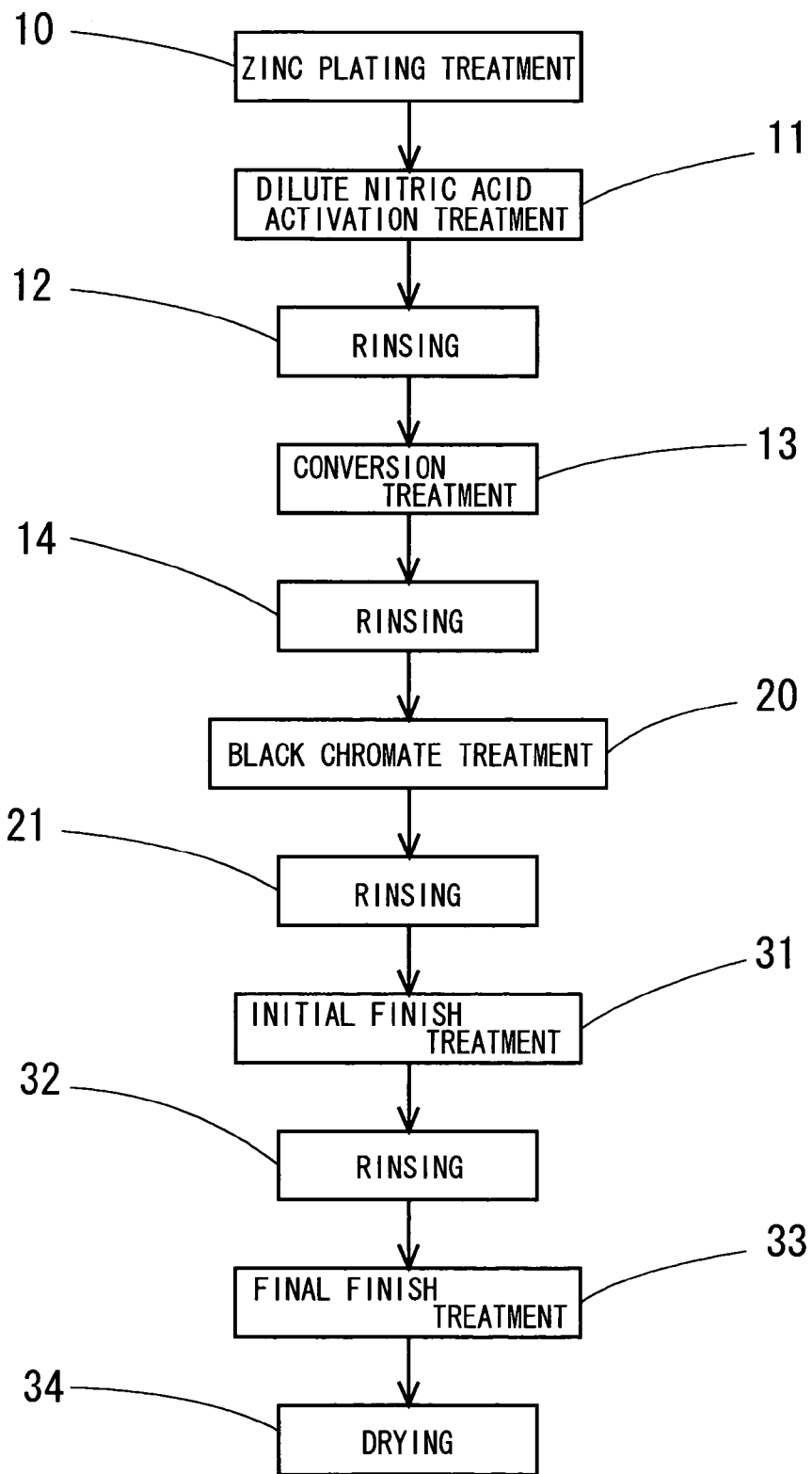
**Fig.3**



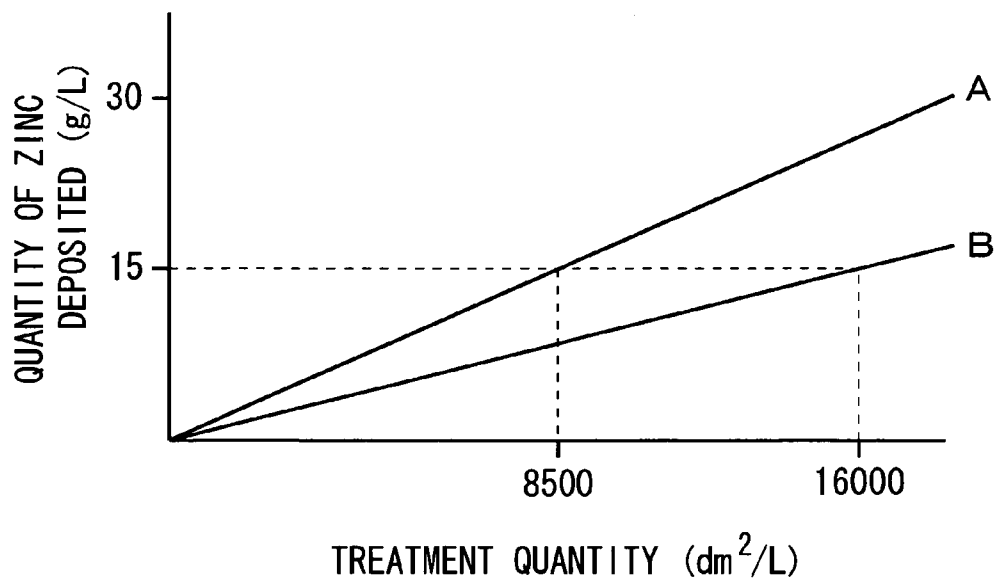
**Fig.4**



**Fig.5**



**Fig.6**



**Fig.7**



## BLACK HEXAVALENT CHROMIUM-FREE PLATING TREATMENT SYSTEM

### BACKGROUND OF THE INVENTION

#### [0001] 1. Field of the Invention

[0002] The present invention relates to a black hexavalent chromium-free plating treatment system which is so designed that a corrosion resistance equal or similar to that of metal parts applied with hexavalent chromate treatment is maintained and environmental pollution is eliminated as much as possible not by application of conventional hexavalent chromate treatment, but by application of black trivalent chromate treatment to the surface of a metal part.

#### [0003] 2. Description of the Related Art

[0004] As a method for preventing the surface of metal from corrosion, generally adopted is to apply zinc or zinc alloy plating to the surface of the base of a metal part to maintain the corrosion resistance. However, a sufficient corrosion resistance cannot be achieved by only the plating and a treatment with chromic acid including hexavalent chromium, namely chromate treatment is usually carried out after the plating treatment. However, it has lately been found that a prolonged contact of the human skin with the metal part treated with chromate including hexavalent chromium may cause the risk that the chromate is absorbed and accumulated in the body to cause chromium tumor, chromium allergy or the like. In addition, it is also known that when treated parts or products using the same are left stand in the atmosphere, hexavalent chromium is absorbed into the body through, for example, the digestive tract, the lung, the skin and the like to cause cancer because hexavalent chromium easily vaporizes. Moreover, when the parts or products are buried in the ground as waste or are used for a long time, that component is eluted into the ground or harmful substances penetrate into the ground, causing soil pollution, which leads to environmental pollution such as pollution of water sources and penetration into plants. Therefore, there are worldwide lively moves to restrict the use of hexavalent chromium. In the industrial communities, demands for restriction of use of parts applied with such treatment and shift to substitutes are increasing.

[0005] In light of such demands, chromate treatment using a trivalent chromium solution has recently been increasing in place of the chromate treatment using hexavalent chromium. One example of such plating treatment is disclosed in JP-B No. 3,332,374. This invention intends to obtain a treatment solution such that from the solution at a very low treatment concentration, a coating which contains no hexavalent chromium and which has a corrosion resistance equal or similar to that of conventional hexavalent chromium-containing coating can be formed on the surface of a metal base having thereon zinc or zinc alloy plating. The invention also intends to obtain a method for forming a coating using the solution. The invention provides a hexavalent chromium-free corrosion resistant trivalent chromate coating superior in hot corrosion resistance by forming a trivalent chromate coating containing a slightly soluble cobalt oxalate and Si on the surface of a metal base having thereon zinc plating deposited by use of a trivalent chromate treatment solution.

[0006] In the treatment solution and the plating treatment method using the same, a corrosion resistance is indeed

obtained which is equal or similar to that achieved by the plating treatment using hexavalent chromium. However, regarding a metal part applied with this treatment, only a coating in white or in pale blue near white is obtained on the surface of the base of a metal part and any glossy black surface coating, the demand for which is increasing in order to impart heavy feeling to parts, has not been obtained. Accordingly, only the conventional ways to obtain such a black coating are still to carry out a chromate treatment using hexavalent chromium or to apply black paint. Therefore, existing challenges include to urgently obtain a black coating having a corrosion resistance equal or similar to that of a black coating by a hexavalent chromate treatment by a trivalent chromium treatment like the above conventional example.

### SUMMARY OF THE INVENTION

[0007] The object of the present invention is to provide a black trivalent chromate treatment which can yield plated products having a black trivalent chromate-treated coating superior in corrosion resistance and which has less bad influence on human bodies and the environment.

[0008] In order to achieve this object, in one black hexavalent chromium-free plating treatment system of the present invention, the surface of a metal part as a base is plated with zinc in a zinc plating treatment step **10** and the surface of the zinc-plated coating is activated in a treatment solution in a dilute nitric acid activation treatment step **11**. Then the activated metal part is rinsed, or is washed with water, so that nitric acid components are removed. Subsequently, a black coating is formed on the rinsed metal part in an inorganic salt solution containing trivalent chromium and iron components as main ingredients in a black chromate treatment step **20**. After the subsequent re-rinsing, the re-rinsed black-coated metal part is subjected to a finish treatment by forming a conversion coating on the re-rinsed metal part in a solution of inorganic salt and organic acid containing trivalent chromium and silica as main ingredients in a finish treatment step **30**. The resulting metal part is dried in a drying step **34**. Thus, a black trivalent chromate-treated coating is obtained which improves the corrosion resistance of the surface of the metal part.

[0009] In addition, in order to achieve the object previously mentioned, in another black hexavalent chromium-free plating treatment system of the present invention, the surface of a metal part as a base is plated with zinc in a zinc plating treatment step **10** and the surface of the zinc-plated coating is activated in a treatment solution in a dilute nitric acid activation treatment step **11**. Then the activated metal part is rinsed, so that nitric acid components are removed. Subsequently, a black regulation coating is formed on the rinsed metal part in a solution of inorganic salt and organic acid containing trivalent chromium and silica components as main ingredients in a chemical conversion treatment step **13** which is arranged next to the rinsing step. After a rinse of the coated metal part, a black coating is formed on the rinsed coated metal part in an inorganic salt solution containing trivalent chromium and iron components as main ingredients in a black chromate treatment step **20**. Subsequently, the black coated metal part is re-rinsed and then the re-rinsed metal part is subjected to a finish treatment in a finish treatment step **30** by forming a conversion coating on the re-rinsed metal part in a solution of inorganic salt and organic



acid which contains trivalent chromium and silica as main ingredients and is less concentrated than the solution used in the foregoing conversion treatment step 13. Then the finished metal part is dried in a drying step 34. This procedure can also yield a black trivalent chromate-treated coating which improves the corrosion resistance of the surface of the metal part.

[0010] It is preferable that the aforementioned finish treatment step comprises an initial finish treatment step 31 in which a conversion coating is formed in a solution of inorganic salt and organic acid which contains trivalent chromium and silica as main ingredients and a final finish treatment step 33 in which after rinsing following the initial finish treatment, the rinsed metal part is immersed in any one of an overcoat treatment solution containing silica and cobalt as main ingredients and a water-soluble anti-corrosive solution. This allows the corrosion resistance of the black trivalent chromate-treated coating to be held for a long term.

#### BRIEF DESCRIPTION OF THE DRAWINGS

[0011] FIG. 1 is a treatment flow diagram of First Example showing one embodiment of the present invention.

[0012] FIG. 2 is an outside drawing of a screw obtained by the present invention.

[0013] FIG. 3 is a treatment flow diagram illustrating Second Example of the present invention.

[0014] FIG. 4 is a treatment flow diagram illustrating Third Example of the present invention.

[0015] FIG. 5 is a treatment flow diagram illustrating Fourth Example of the present invention.

[0016] FIG. 6 is a graph showing the relation of the quantity of zinc deposited with respect to the quantity of parts treated in the present invention.

[0017] FIG. 7 is a graph showing the relation between the quantity of zinc deposited and the time to the occurrence of corrosion according to the present invention.

#### DETAILED DESCRIPTION OF THE INVENTION

[0018] Embodiments of the present invention will now be described with reference to the accompanying drawings. In FIG. 2, referential numeral 1 indicates a screw which is one example of the metal part for which the present invention is applied. This screw 1 has a base made of iron-based material. This screw has at its head a cross-shaped recess 3 with a tightening surface and on its shank 4 a thread 5 with a predetermined pitch, which are formed by a heading process and a rolling process, respectively. The base has been zinc plated on its surface. On the surface of the zinc-plated base, a black chromate-treated coating has been formed. This coating has been formed by black trivalent chromate treatment for imparting heavy feeling as well as corrosion resistance, such as salt-water resistance and exposure resistance. The black trivalent chromate coating 6 has less influence on the environment, such as vaporization of its ingredients at normal temperatures and their penetration into the ground, than hexavalent chromate coatings.

[0019] The following is a description on a plating treatment steps in the trivalent chromate treatment. FIG. 1

illustrates First Example of the present invention. In FIG. 1, referential numeral 10 indicates a zinc plating treatment step in which zinc plating is applied to the surface of the base of the metal part. Following this step, a dilute nitric acid activation treatment step 11 is arranged. In the nitric acid activation treatment step 11, the surface of the zinc-plated coating covering the surface of the base is activated, so that an oxide coating on the zinc-plated coating is removed. The step 11 is followed by a rinsing step 12, which is so designed that nitric acid components attached in the foregoing step are washed away with water. Next to this step, a black chromate treatment step 20 is arranged. This step is so designed that the base from which nitric acid components have been washed away in the rinsing step 12 is subjected to an immersion treatment in an inorganic salt solution containing trivalent chromium and iron components as main ingredients, so that a black trivalent chromate coating 6 is formed on the zinc-plated coating. Next to this step, a rinsing step 21 is arranged. Subsequent to this step, a finish treatment step 30 is arranged in order to improve the corrosion resistance of the black trivalent chromate coating 6 formed in the foregoing step. The finish treatment step includes a solution of inorganic salt and organic acid containing trivalent chromium and silica as main ingredients. In this step, a conversion coating is formed on the black trivalent chromate coating. The base having thereon the black trivalent chromate coating on which the conversion coating has been formed is dried in a subsequent drying step 34, thereby finalizing the production of a metal part with an improved corrosion resistance.

[0020] Via such a treatment step, the base is first subjected to zinc plating. The resultant is therefore transferred to a dilute nitric acid activation treatment step 11 and is immersed in the solution at normal temperature for a short period of time. Through this treatment, the oxide coating formed on the zinc-plated surface is activated and removed. Thus, the zinc-plated coating is activated. The treated base is subsequently rinsed, so that nitric acid components are removed. The resulting base is then immersed, for a predetermined time, in a treatment solution for use in the black chromate treatment step 20, the solution containing trivalent chromium and iron as main ingredients. Thus, a black trivalent chromate coating 6 is formed. The base is rinsed again for the purpose of washing away that solution. The ingredients of the black chromate treatment solution are thereby removed and the resulting base is supplied to the next finish treatment step 30 for improving the corrosion resistance and is subjected to a finish treatment. Then the base is dried in a drying step 34 to yield a product.

[0021] On the other hand, FIG. 3 illustrates Second Example, which includes a conversion treatment step 13 intervening between the dilute nitric acid activation treatment step 11 and the black chromate treatment step 20 in First Example. After the rinsing step 12 in which the metal part treated in the dilute nitric acid activation treatment step 11 is rinsed, the conversion treatment step 13 is arranged. This step is so designed that a black regulation coating is formed in a solution of inorganic salt and organic acid containing trivalent chromium and silica as main ingredients. The treatment step 13 further precipitates and removes the zinc-plated coating formed on the base and simultaneously forms a conversion coating composed mainly of chromium and silica. Although this solution contains the same main ingredients as those of the solution used in the

finish treatment step **30** previously mentioned, the concentrations thereof are set to be higher than those used in the finish treatment step **30**. Like every other step, the conversion treatment step **13** also has a rinsing step **14**, after which the aforementioned black chromate treatment step **20** is arranged.

[0022] FIG. 4 shows Third Example in which the finish treatment step **30** is designed to be a two-step finish treatment including an initial finish treatment step **31** and a final finish treatment step **33** in place of the finish treatment step **30** in the treatment process shown in the First Example. The initial finish treatment step **31** in this case is, like the finish treatment step **30** in the First and Second Examples described above, composed of a solution of inorganic salt and organic acid containing trivalent chromium and silica as main ingredients in order to improve the corrosion resistance of the black trivalent chromate coating formed in the foregoing step. The initial finish treatment step **31** is so designed that a conversion coating is formed on a black trivalent chromate coating like the finish treatment step **30** in the foregoing Examples. The initial finish treatment step **31** is also followed by a subsequent rinsing step **32**, so that the solution components coming from the initial finish treatment step **31** are washed away. Following this step, the final finish treatment step **33** is arranged.

[0023] In the final finish treatment step **33**, immersion in any one of an overcoat treatment solution containing silica and cobalt as main ingredients and a water-soluble anti-corrosive solution is carried out. By the immersion, the surface of the black trivalent chromate coating treated in the initial finish treatment step **31** is provided with a coating thereon for enhancing the corrosion resistance of the initially-finished black trivalent chromate coating.

[0024] FIG. 5 illustrates Fourth Example in which the finish treatment step **30** is, like Example 3, designed to be a two-step finish treatment including an initial finish treatment step **31** and a final finish treatment step **33** in place of the finish treatment step **30** in the treatment process shown in the Second Example. The details of the finish treatment are the same as those of the Third Example and, therefore, the explanation of the treatment is omitted here. The Fourth Example is the best treatment process by which corrosion resistance can be demonstrated most effectively in the formation of a black trivalent chromate coating **6**.

[0025] Regarding the corrosion resistance of the bases obtained in the manners described above, the time required for 5% of white corrosion product of zinc to be formed was visually measured according to JIS H 8502 "Methods of corrosion resistance test for metallic coatings." The results are shown in Table 1. The condition for the measurement is salt spray test using ten screws as samples for each test.

TABLE 1

EXAMPLE	APPEARANCE OF COATING	RANGE OF WHITE CORROSION PRODUCT FORMATION TIME (H)
1	BLACK	120-192
2	BLACK	120-192
3	BLACK	168-216
4	BLACK	168-216

TABLE 1-continued

EXAMPLE	APPEARANCE OF COATING	RANGE OF WHITE CORROSION PRODUCT FORMATION TIME (H)
CONVENTIONAL EXAMPLE	BLACK	120-240

[0026] The test has confirmed that a screw **1** with a black trivalent chromate coating **6** in accordance with the present invention has a corrosion resistance (range of white corrosion product formation time) approximately equal to that of screws using conventional black hexavalent chromate coatings.

[0027] In the black trivalent chromate treatments in above-mentioned Examples, the change in the quantity of zinc deposited in the inorganic salt solution containing trivalent chromium and iron components as main ingredients stored in the treatment tank (not shown in drawings) in the black chromate treatment step **20** is shown in FIG. 6 by use of the relation between that quantity and the quantity of treated screws. In First and Third Examples, a large quantity of zinc was deposited in the black chromate treatment step **20** as indicated by "A". That is, it is shown that the quantity of zinc deposited reached the standard deposition quantity (15 g/L) at a small quantity of treated screws (8,500 dm<sup>2</sup>/L). Therefore, the solution in the tank must be changed or replenished frequently in order to keep the quality of products. In contrast, in Second and Fourth Examples, a small quantity of zinc was deposited as indicated by "B". That is, it is shown that the quantity of zinc deposited reached the standard deposition quantity (15 g/L) at a large quantity of items treated (16,000 dm<sup>2</sup>/L). Therefore, the solution in the tank is not required to be changed or replenished so frequently. Such a difference depends on whether a conversion treatment step **13** was conducted as a step prior to the black chromate treatment step. What Example should be chosen for the treatment of screws may be determined by taking the number of the steps contained in the process and the cost thereof.

[0028] FIG. 7 is a graph relates to the corrosion resistance in the black chromate treatment step **20** and demonstrates the relation between the quantity of zinc deposited (g/L) and the time to the occurrence of corrosion (H). The items which were treated before the quantity of zinc deposited reached to the standard deposition quantity (15 g/L), required at least 100 hours before the formation of 5% of the white corrosion product in the salt spray test demonstrating their corrosion resistance. However, the items with deposition quantities larger than the standard deposition quantity tend to require considerably short times before the formation of 5% of the white corrosion product. Setting the standard deposition quantity makes it possible to maintain the solution concentration for obtaining a desired corrosion resistance.

[0029] As is clear from the above description, a black trivalent chromate coating formed by use of the present invention can have a corrosion resistance and strength equal or similar to those of conventional black hexavalent chromate coatings. According to the present invention a black trivalent chromate coating with heavy feeling is obtained for the first time and the invention permits glossy black coatings

to be formed. Thus, in the formation of black coatings which are increasingly demanded, the black trivalent chromate coating can sufficiently meet the environmental problems with lately increasing requirements and the reliability thereof is improved. In addition, conducting the black trivalent chromate treatment through such a process will elongate the life of the solution used in the treatment step and will achieve an accurate control. Moreover, because the coating is one which is made mainly of trivalent chromium, the amount of penetration into the ground will be reduced. Therefore, the probability of the occurrence of the soil pollution caused by the penetration of harmful substances into the ground is reduced and the influence on environmental pollution such as pollution of water source and penetration into plants is also reduced. Furthermore, because the finish treatment uses any one of an overcoat solution containing silica, cobalt and the like as main ingredients and a water-soluble anti-corrosive solution, it is possible to repair slight scratch marks formed in the former steps and unique effects such as improvement of quality of products can be obtained.

What is claimed is:

1. A black hexavalent chromium-free plating treatment system which is designed so that the corrosion resistance of a surface of a metal part is improved by

plating the surface of the metal part as a base with zinc in a zinc plating treatment step (10),

activating a surface of the zinc-plated coating in a treatment solution in a dilute nitric acid activation treatment step (11),

then rinsing the activated metal part to remove nitric acid components,

subsequently forming a black coating on the rinsed metal part in an inorganic salt solution containing trivalent chromium and iron components as main ingredients in a black chromate treatment step (20),

rerinsing the black coated metal part,

then subjecting the rerinsed metal part to a finish treatment by forming a conversion coating on the rerinsed metal part in a solution of inorganic salt and organic

acid containing trivalent chromium and silica as main ingredients in a finish treatment step (30), and

drying the finished metal part in a drying step (34).

2. A black hexavalent chromium-free plating treatment system which is designed so that the corrosion resistance of a surface of a metal part is improved by

plating the surface of the metal part as a base with zinc in a zinc plating treatment step,

activating a surface of the zinc-plated coating in a treatment solution in a dilute nitric acid activation treatment step,

then rinsing the activated metal part to remove nitric acid components,

forming a black regulation coating on the rinsed metal part in solution of inorganic salt and organic acid containing trivalent chromium and silica as main ingredients in a conversion treatment step (13) which is arranged next to the rinsing step,

rinsing the coated metal part,

subsequently forming a black coating on the rinsed coated metal part in an inorganic salt solution containing trivalent chromium and iron components as main ingredients in a black chromate treatment step,

rerinsing the black coated metal part,

then subjecting the rerinsed metal part to a finish treatment in a finish treatment step by forming a conversion coating on the rerinsed metal part in a solution of inorganic salt and organic acid which contains trivalent chromium and silica as main ingredients and is less concentrated than the solution used in the foregoing conversion treatment step, and

drying the finished metal part in a drying step.

3. The black hexavalent chromium-free plating treatment system according to claim 1 or 2 wherein the finish treatment step comprises an initial finish treatment step (31) in which a conversion coating is formed in a solution of inorganic salt and organic acid which contains trivalent chromium and silica as main ingredients and a final finish treatment step (33) in which after rinsing following the initial finish treatment, the rinsed metal part is immersed in any one of a overcoat treatment solution containing silica and cobalt as main ingredients and a water-soluble anti-corrosive solution.

\* \* \* \* \*