

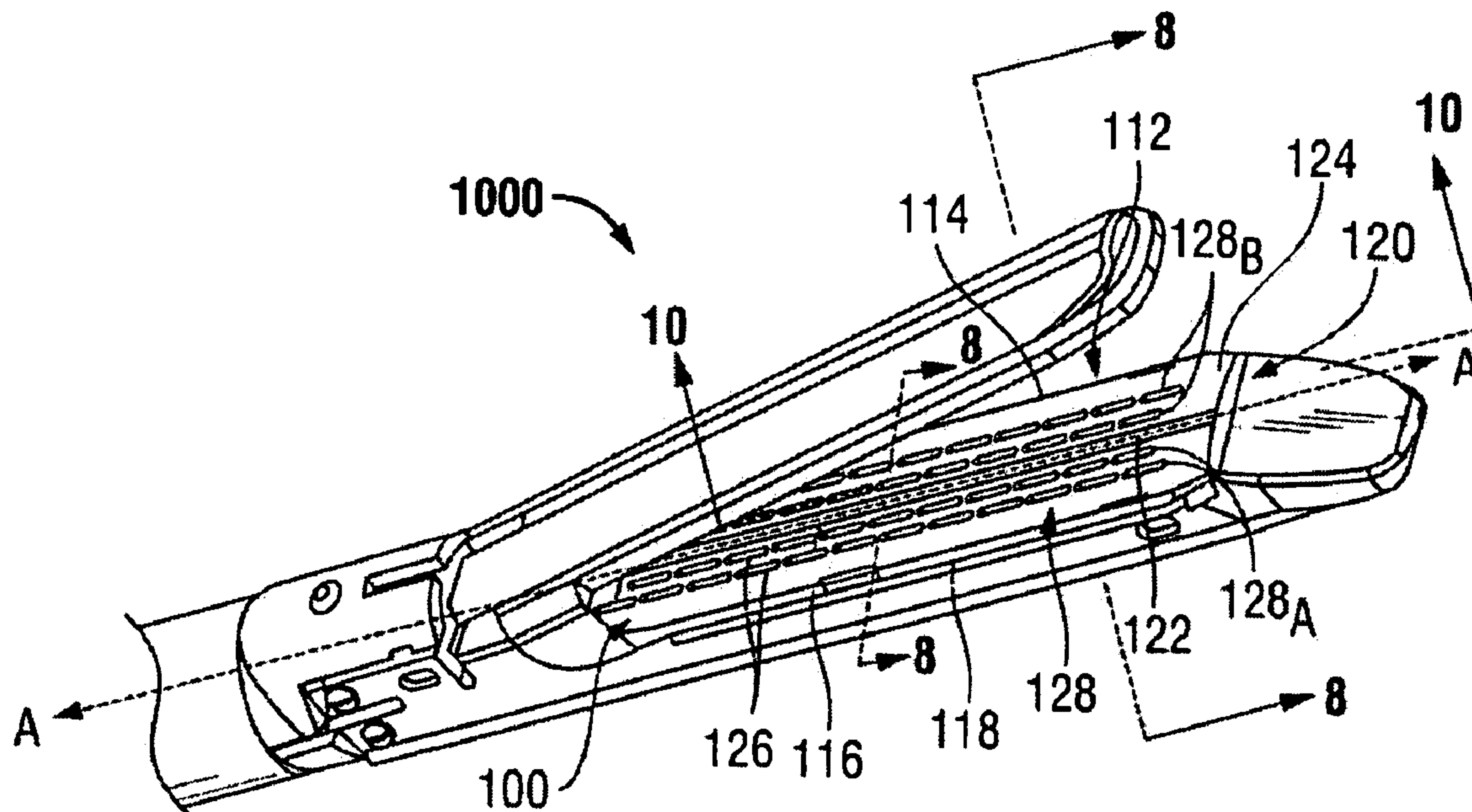

(22) Date de dépôt/Filing Date: 2009/04/09  
 (41) Mise à la disp. pub./Open to Public Insp.: 2009/10/14  
 (45) Date de délivrance/Issue Date: 2016/11/15  
 (30) Priorités/Priorities: 2008/04/14 (US61/044,696);  
 2008/04/14 (US61/044,656); 2009/04/03 (US12/417,685)

(51) Cl.Int./Int.Cl. *A61B 17/03* (2006.01),  
*A61B 17/064* (2006.01), *A61B 17/072* (2006.01),  
*A61B 17/115* (2006.01)  
 (72) Inventeurs/Inventors:  
 VIOLA, FRANK J., US;  
 MILLIMAN, KEITH L., US  
 (73) Propriétaire/Owner:  
 TYCO HEALTHCARE GROUP LP, US  
 (74) Agent: OSLER, HOSKIN & HARCOURT LLP

(54) Titre : CARTOUCHE D'ATTACHES CHIRURGICALES A COMPRESSION VARIABLE  
 (54) Title: VARIABLE COMPRESSION SURGICAL FASTENER CARTRIDGE



(57) Abrégé/Abstract:

A surgical fastener applying apparatus having a first jaw and a second jaw. The first jaw includes a cartridge body having plurality of surgical fasteners disposed therein. The plurality of surgical fasteners include a plurality of first surgical fasteners having a first backspan with a first configuration, and a plurality of second surgical fasteners having a second backspan with a second, different configuration such that the plurality of first surgical fasteners apply a first compressive force to tissue upon formation and the plurality of second surgical fasteners apply a second, different compressive force to tissue upon formation.

**ABSTRACT**

A surgical fastener applying apparatus having a first jaw and a second jaw. The first jaw includes a cartridge body having plurality of surgical fasteners disposed therein. The plurality of surgical fasteners include a plurality of first surgical fasteners having a first backspan with a first configuration, and a plurality of second surgical fasteners having a second backspan with a second, different configuration such that the plurality of first surgical fasteners apply a first compressive force to tissue upon formation and the plurality of second surgical fasteners apply a second, different compressive force to tissue upon formation.

## VARIABLE COMPRESSION SURGICAL FASTENER CARTRIDGE

### BACKGROUND

#### 1. Technical Field

[0001] The present disclosure relates to surgical fastener applying apparatus. More particularly, the present disclosure relates to surgical fastener applying apparatus that include surgical fasteners that are configured to apply varying compressive forces in tissue.

#### 2. Background of the Related Art

[0002] Many varieties of surgical fastener applying apparatus are known in the art, some of which are specifically adapted for use in various surgical procedures including, but not limited to, end-to-end anastomosis, circular end-to-end anastomosis, open gastrointestinal anastomosis, endoscopic gastrointestinal anastomosis, and transverse anastomosis. Suitable examples of apparatus which may be used during the course of these procedures can be seen in U.S. Pat. Nos. 5,915,616; 6,202,914; 5,865,361; and 5,964,394.

[0003] In general, a surgical fastener applying apparatus will include an anvil that is approximated relative to a surgical fastener cartridge during use or a fastener cartridge that is approximated relative to an anvil. The anvil includes depressions that are aligned with, and/or are in registration with slots defined in the surgical fastener cartridge, through which the fasteners will emerge. To effectuate formation, the fasteners emerge from the surgical fastener cartridge and are driven against the anvil. The surgical fastener cartridge typically has one or more rows of fasteners disposed laterally outward of a channel or knife slot that is configured to accommodate a knife, or other such cutting element, such that tissue can be simultaneously

severed and joined together. Depending upon the particular surgical fastener applying apparatus, the rows of fasteners may be arranged in a linear, non-linear, e.g. circular, semi-circular, arcuate, or other configuration.

[0004] Various types of surgical fasteners are well known in the art including, but not limited to, unitary fasteners and two-part fasteners. Unitary fasteners generally include a pair of legs that are adapted to penetrate tissue and connected by a backspan from which they extend. In use, subsequent to formation, certain types of unitary fasteners have a “B” shaped configuration. Typically, the two-part fastener includes legs that are barbed and connected by a backspan. The legs are engaged and locked into a separate retainer piece that is usually located in the anvil. In use, the two-part fastener is pressed into the tissue so that the barbs penetrate the tissue and emerge from the other side where they are then locked into the retainer piece.

[0005] During each of the aforementioned surgical procedures, the tissue is initially gripped or clamped between the cartridge and anvil such that individual fasteners can be ejected from the cartridge, through the slots, and forced through the gripped tissue. Thereafter, the fasteners are formed by driving them into the depressions formed on the anvil.

[0006] A common concern in each of the procedures mentioned above is hemostasis, or the rate at which bleeding of the target tissue is stopped. It is commonly known that by increasing the amount of pressure applied to a wound, the flow of blood can be limited, thereby decreasing the time necessary to achieve hemostasis. To this end, conventional surgical fastener applying apparatus generally apply two or more rows of fasteners about the cut-line to compress the surrounding tissue in an effort to stop any bleeding and to join the cut tissue together. Each of the fasteners will generally apply a compressive force to the tissue sufficient to effectuate

hemostasis. However, applying too much pressure can result in a needless reduction in blood flow to the tissue surrounding the cut-line, resulting in an elevated level of necrosis, a slower rate of healing, and/or a greater recovery period.

[0007] Consequently, it would be advantageous to provide a surgical fastener applying apparatus capable of limiting the flow of blood in the tissue immediately adjacent the cut-line to effectuate hemostasis and wound closure, while maximizing blood flow in the surrounding tissue to facilitate healing.

[0008] Additionally, when tissue is clamped and compressed between the anvil and the surgical fastener cartridge, some of the fluid of the tissue is squeezed out so the tissue is compressed further at the center portions of the cartridge and anvil than at the lateral edges, thereby leaving thicker tissue at the edges. It would therefore be advantageous to provide surgical fasteners which could better accommodate these resulting different tissue thicknesses.

### **SUMMARY**

[0009] In one aspect of the present disclosure, a surgical fastener applying apparatus is disclosed having a first jaw and a second jaw. The first jaw includes a cartridge body having plurality of surgical fasteners disposed therein. The plurality of surgical fasteners include a plurality of first surgical fasteners having a first backspan with a first configuration, and a plurality of second surgical fasteners having a second backspan with a second, different configuration such that the plurality of first surgical fasteners apply a first compressive force to tissue upon formation and the plurality of second surgical fasteners apply a second, different compressive force to tissue upon formation.

[0010] In one embodiment, the first surgical fasteners are arranged in a first row and the second surgical fasteners are arranged in a second row laterally outward of the first row wherein the first and second backspans are configured and dimensioned such that the first compressive force is greater than the second compressive force, whereby blood flow through tissue surrounding the plurality first surgical fasteners after formation is less than blood flow through tissue surrounding the plurality of second surgical fasteners after formation.

[0011] In some embodiments, each surgical fastener in the plurality of surgical fasteners defines a substantially equivalent overall height when formed in the tissue.

[0012] In one embodiment, the first configuration of the first backspan of the plurality of first surgical fasteners include a twisted configuration defining a first height, and the second configuration of the second backspan of the plurality of second surgical fasteners include a backspan having a twisted configuration defining a second height less than the first height.

[0013] The cartridge body may include a channel that is configured to accommodate a cutting member for the creation of a cut-line in the patient's tissue. When the plurality of surgical fasteners are arranged within the cartridge body, the plurality of first surgical fasteners may be arranged to define a pair of first rows disposed laterally outwardly of the channel, and the second surgical fasteners may be arranged to define a pair of second rows disposed laterally outwardly of the pair of first rows.

[0014] In some embodiments, the plurality of surgical fasteners loaded into the cartridge body may further include a plurality of third surgical fasteners each with a third backspan having a third configuration that is different than at least one, and preferably both, of the respective first

and second configurations of the first and second backspans. The third fasteners can be arranged in a third pair of rows laterally outward of the pair of second rows.

[0015] The third fasteners may be configured and dimensioned to apply a third compressive force to the tissue upon formation of the plurality of third surgical fasteners that is different than at least one, and preferably both, of the respective first and second compressive forces applied to the tissue by the first and second backspans upon formation of the plurality of first surgical fasteners and the plurality of second surgical fasteners. Preferably, the first compressive force is greater than the third compressive force, whereby blood flow through the tissue surrounding the plurality of first surgical fasteners after formation is less than blood flow through the tissue surrounding the plurality of third surgical fasteners after formation. Preferably, the third backspan is configured and dimensioned such that the second compressive force is greater than the third compressive force, whereby blood flow through the tissue surrounding the plurality of second surgical fasteners after formation is less than blood flow through the tissue surrounding the plurality of third surgical fasteners after formation.

[0016] In one embodiment, the third backspan of the plurality of third surgical fasteners may be substantially linear in configuration. Alternatively, the third backspan may have a twisted configuration which is preferably similar to the twisted backspan of the second fasteners, except defining a third height that is less than the second height defined by the second backspan of the plurality of second surgical fasteners or alternatively have an inwardly directed curve defining a third height less than second height.

[0017] In an alternative embodiment, the plurality of first surgical fasteners include first legs extending from the first backspan and terminating in penetrating ends, as well as at least one

curve that is formed in the first backspan, wherein the at least one curve extends towards the penetrating ends and is dimensioned to define a first height. Additionally, or alternatively, the plurality of second surgical fasteners may include second legs extending from the second backspan and terminating in penetrating ends, as well as at least one curve that is formed in the second backspan, wherein the at least one curve extends towards the penetrating ends and is dimensioned to define a second height that is less than the first height.

**[0018]** In another aspect of the present disclosure, a surgical fastener cartridge is provided including a plurality of surgical fasteners disposed therein. The plurality of surgical fasteners include a plurality of first surgical fasteners arranged in a first row and having a first backspan with a first configuration, and a plurality of second surgical fasteners arranged in a second row and having a second backspan with a second configuration. The first backspan has a first height and the second backspan has a second height, the first height being less than the second height.

**[0019]** In one embodiment, the first and second backspans have a twisted configuration and the first fastener applies a first compressive force to tissue upon formation, and the second surgical fasteners apply a second, lesser compressive force to tissue upon formation.

**[0020]** In one embodiment, the first surgical fasteners include first legs extending from the first backspan and terminating in penetrating ends and the second surgical fasteners include second legs extending from the second backspan and terminating in penetrating ends, wherein the first backspan includes at least one portion curving inwardly toward the penetrating ends of the first legs to form a humped configuration and dimensioned to define a first height, and the second backspan includes at least one portion curving inwardly toward the penetrating ends of

the second legs to form a humped configuration and dimensioned to define a second height different from the first height.

[0021] In preferred embodiments, the plurality of first fasteners define a pair of first rows and the plurality of second surgical fasteners define a pair of second rows disposed further from the central longitudinal axis of the cartridge than the pair of first rows.

[0022] The cartridge may include a plurality of third surgical fasteners having a third backspan with a third configuration such that the plurality of third surgical fasteners apply a third compressive force to the tissue upon formation that is different from at least one of the first compressive force and the second compressive force respectively applied to the tissue by the plurality of first surgical fasteners and the plurality of second surgical fasteners upon formation, the third fasteners being disposed further from the central longitudinal axis of the pair of first rows.

[0023] These and other features of the surgical fastener applying apparatus, surgical fastener cartridge, and surgical fasteners disclosed herein will become more readily apparent to those skilled in the art through reference to the detailed description of various embodiments of the present disclosure that follows.

#### **BRIEF DESCRIPTION OF THE DRAWINGS**

[0024] Various embodiments of the present disclosure are described herein, with references to the drawings, wherein:

[0025] FIG. 1 is a top, perspective view of a distal end portion of a surgical fastener applying apparatus including a surgical fastener cartridge in accordance with one embodiment of the present disclosure;

[0026] FIG. 2 is a side, perspective view of one embodiment of a surgical fastener, including a substantially linear backspan and shown prior to formation, for use with the surgical fastener cartridge seen in FIG. 1;

[0027] FIG. 3 is a cross-sectional view of the surgical fastener shown in FIG. 2 subsequent to formation within adjacent tissue segments;

[0028] FIG. 4 is a side, perspective view of an alternative embodiment of the surgical fastener shown in FIG. 2 including a twisted backspan with a plurality of protrusions defining a first height;

[0029] FIG. 5 is a cross-sectional view of the surgical fastener shown in FIG. 4 formed within adjacent tissue segments;

[0030] FIG. 6 is a side, perspective view of another alternative embodiment of the surgical fastener shown in FIG. 2 including a twisted backspan with a plurality of protrusions defining a second, greater height;

[0031] FIG. 7 is a cross-sectional view of the surgical fastener shown in FIG. 6 formed within adjacent tissue segments;

[0032] FIG. 8 is an axial, cross-sectional view taken through line 8-8 in FIG. 1, which illustrates the surgical fastener cartridge loaded with the surgical fasteners seen in FIGS. 2-5,

wherein the surgical fasteners shown in FIGS. 4, 5 are arranged in a pair of inner rows and the surgical fasteners shown in FIGS. 2, 3 are arranged in a pair of outer rows;

[0033] FIG. 9 is a partial, longitudinal, perspective view, with parts removed, of the surgical fastener cartridge seen in FIG. 8 illustrating the plurality of surgical fasteners arranged into inner and outer rows;

[0034] FIG. 10 is a partial, longitudinal, cross-sectional view of the surgical fastener cartridge of seen in FIG. 8 taken through line 10-10 in FIG. 1, which illustrates an inner and outer row of surgical fasteners;

[0035] FIG. 11 is a top, perspective view of an alternative embodiment of the surgical fastener cartridge seen in FIG. 1 loaded with a plurality of surgical fasteners arranged into inner rows, intermediate rows, and outer rows;

[0036] FIG. 12 is an axial, cross-sectional view taken through line 12-12 in FIG. 11, which illustrates the surgical fastener cartridge loaded with the surgical fasteners seen in FIGS. 2-7, wherein the surgical fasteners shown in FIGS. 6, 7 are arranged in the inner rows, the surgical fasteners shown in FIGS. 4, 5 are arranged in the intermediate rows, and the surgical fasteners shown in FIGS. 2, 3 are arranged in the outer rows;

[0037] FIG. 13 is a partial, longitudinal, perspective view, with parts removed, of the surgical fastener cartridge seen in FIG. 12 illustrating the plurality of surgical fasteners arranged into inner, intermediate, and outer rows;

**[0038]** FIG. 14 is a partial longitudinal, cross-sectional view of the surgical fastener cartridge of FIG. 12 taken through line 14-14 in FIG. 11, which illustrates an inner, intermediate, and outer row of surgical fasteners;

**[0039]** FIG. 15 illustrates an exemplary surgical fastener applying apparatus for use with the surgical fastener cartridge seen in FIG. 1 during a laparoscopic surgical procedure;

**[0040]** FIG. 16 is a partial, perspective view of a tool assembly of the surgical fastener applying apparatus seen in FIG. 15, with parts separated, illustrating an anvil and the surgical fastener cartridge of FIG. 1;

**[0041]** FIG. 17 illustrates an end-to-end anastomosis device for use with an alternative embodiment of the surgical fastener cartridge seen in FIG. 1 during a surgical anastomosis procedure;

**[0042]** FIG. 18 illustrates a surgical fastener applying instrument for use with yet another alternative embodiment of the surgical fastener cartridge seen in FIG. 1 during an open gastrointestinal anastomotic fastening procedure;

**[0043]** FIG. 19 illustrates a transverse anastomosis fastener applying instrument for use with an alternative embodiment of the surgical fastener cartridge shown in FIG. 18;

**[0044]** FIG. 20 is a top, perspective view of another alternative embodiment of the surgical fastener cartridge seen in FIG. 1 according to the principles of the present disclosure;

**[0045]** FIG. 21 is a side, perspective view of an alternative embodiment of the surgical fastener shown in FIG. 2 including a backspan with a plurality of recesses forming projections and defining a first height;

**[0046]** FIG. 22 is a cross-sectional view of the surgical fastener shown FIG. 21 formed within adjacent tissue segments;

**[0047]** FIG. 23 is a side, perspective view of another alternative embodiment of the surgical fastener shown in FIG. 2 including a backspan with a plurality of recesses forming projections defining a second, greater height;

**[0048]** FIG. 24 is a cross-sectional view of the surgical fastener shown in FIG. 23 formed within adjacent tissue segments;

**[0049]** FIG. 25 is a partial longitudinal, perspective view with parts removed of the surgical fastener cartridge seen in FIG. 8 loaded with a plurality of the surgical fasteners illustrated in FIGS. 2 and 21, wherein the surgical fasteners shown in FIG. 21 are arranged in a pair of inner rows and the surgical fasteners shown in FIG. 2 are arranged in a pair of outer rows;

**[0050]** FIG. 26 is a partial longitudinal, cross-sectional view of the surgical fastener cartridge shown in FIG. 25 taken through line 10-10 in FIG. 1, which illustrates an inner and outer row of surgical fasteners;

**[0051]** FIG. 27 is a partial top, perspective view of the surgical fastener cartridge seen in FIG. 11 when loaded with a plurality of the surgical fasteners illustrated in FIGS. 2, 21, and 23, wherein the surgical fasteners shown in FIG. 23 are arranged in a pair of inner rows, the surgical

fasteners shown in FIG. 21 are arranged in a pair of intermediate rows, and the surgical fasteners shown in FIG. 2 are arranged in a pair of outer rows; and

[0052] FIG. 28 is a partial longitudinal, cross-sectional view of the surgical fastener cartridge shown in FIG. 27 taken through line 14-14 in FIG. 11, which illustrates an inner, intermediate, and outer row of surgical fasteners.

### **DETAILED DESCRIPTION OF EXEMPLARY EMBODIMENTS**

[0053] Various exemplary embodiments of the presently disclosed surgical fastener applying apparatus, surgical fastener cartridge, and surgical fasteners will now be described in detail with reference to the drawings wherein like reference characters identify similar or identical elements. In the drawings, and in the description which follows, the term “proximal” will refer to the end of the surgical fastener applying apparatus that is closer to the clinician during use, while the term “distal” will refer to the end that is further from the clinician, as is traditional and conventional in the art. In addition, the term “surgical fastener” should be understood to include any substantially rigid structure that is suitable for the intended purpose of joining tissue together, including but not being limited to surgical staples, clips, and the like.

[0054] FIG. 1 illustrates a distal end portion of an exemplary surgical fastener applying apparatus 1000 including a surgical fastener cartridge 100 in accordance with the principles of the present disclosure. The surgical fastener cartridge 100 extends along a longitudinal axis “A-A,” and includes a cartridge body 112 with a pair of side walls 114, 116, a bottom wall 118, and a top wall 120. The top wall 120 includes a knife slot or channel 122 that is configured to accommodate longitudinal movement of a knife member 123 (FIG. 16) or other cutting element such that tissue may be severed along a cut-line. The top wall 120 further includes a tissue

engaging surface 124 for maintaining the position of the tissue to be cut, and a plurality of fastener retention slots 126 that are arranged into a plurality of rows 128 that extend along the length (longitudinal axis) of the surgical fastener cartridge 100. As shown in FIG. 1, the fastener retention slots 126 are arranged into a pair of first (inner) rows 128<sub>A</sub> that are spaced laterally outward from the channel or knife slot 122, on opposite sides thereof, and a pair of second (outer) rows 128<sub>B</sub> that are spaced laterally outward from the pair of first rows 128<sub>A</sub>, again on opposite sides of the slot 122. While the surgical fastener cartridge 100 is depicted as including pairs of first and second rows 128<sub>A</sub>, 128<sub>B</sub>, respectively, additional rows of fastener retention slots 126 (and fasteners) may be included in alternative embodiments of the surgical fastener cartridge 100, as discussed below. In various embodiments of the present disclosure, it is envisioned that the surgical fastener cartridge 100 may be removable, or replaceable, with another loaded surgical fastener cartridge.

**[0055]** Each of the fastener retention slots 126 is configured to receive one of a plurality of surgical fasteners, e.g., the surgical fasteners and pushers 129 (FIG. 8) such that the surgical fasteners are deployed in rows, e.g. inner and outer rows in the embodiment shown in FIG. 1, on opposite sides of the cut-line created in the tissue during the surgical fastening procedure.

**[0056]** Further details regarding the fastener cartridge 100 may be obtained through reference to U.S. Patent No. 7,070,083.

**[0057]** Referring now to FIGS. 2 and 3 as well, the surgical fastener cartridge 100 is loaded with one or more varieties of surgical fastener, one of which may be the surgical fastener 130. The surgical fastener 130 includes two legs 132 extending from a backspan 134 extending

therebetween. The thickness of the backspan 134 and the legs 132 can be varied such that the surgical fastener 130 may be used to fasten adjacent tissue segments "T<sub>1</sub>," "T<sub>2</sub>" of any thickness.

[0058] The legs 132 and the backspan 134 may define a cross-section having any suitable geometric configuration, including but not being limited to rectangular, oval, square, triangular, trapezoidal, etc. The legs 132 and the backspan 134 may exhibit the same geometrical configuration such that the cross-sectional configuration of the surgical fastener 130 is substantially uniform, as shown in FIGS. 2, 3, or alternatively, the legs 132 and the backspan 134 may exhibit different geometrical configurations, e.g., the legs 132 may exhibit a rectangular cross-sectional configuration whereas the backspan 134 may exhibit an oval cross-sectional configuration.

[0059] Prior to formation of the surgical fastener 130, the legs 132 extend from the backspan 134 such that they are substantially parallel. Alternatively, the legs 132 may converge or diverge from the backspan forming an acute or obtuse angle with the backspan. Each of the legs 132 terminates in a penetrating end 136 that is configured to penetrate tissue, e.g., tissue segments "T<sub>1</sub>," "T<sub>2</sub>" (FIG. 3). The penetrating ends 136 of legs 132 can be tapered to facilitate the penetration of the tissue segments "T<sub>1</sub>," "T<sub>2</sub>," or alternatively, the penetrating ends 136 may not include a taper. In various embodiments of the surgical fastener 130, it is also envisioned that the penetrating ends 136 may alternatively define either conical or flat surfaces, as described in co-pending U.S. Application Serial No. 11/444,761, filed April 13, 2003. The surgical fastener 130 may also be configured as a directionally biased staple, such as that described in commonly owned U.S. Patent No. 7,398,907.

[0060] In the embodiment of the surgical fastener 130 illustrated in FIGS. 2 and 3, the backspan 134 is substantially linear in configuration. When formed within tissue, e.g., within the tissue segments "T<sub>1</sub>," "T<sub>2</sub>" (FIG. 3), the legs 132 of the surgical fastener 130 cooperate with the backspan 134 to maintain adjacent the tissue segments "T<sub>1</sub>," "T<sub>2</sub>" in approximation and apply a compressive force "F" thereto. The compressive force "F" applies pressure to the tissue segments "T<sub>1</sub>," "T<sub>2</sub>," thereby restricting the flow of blood through the tissue surrounding the surgical fastener 130 and facilitating hemostasis. The linear configuration of the backspan 134 limits the amount of pressure that can be applied to the tissue segments "T<sub>1</sub>," "T<sub>2</sub>," however, such that the flow of blood through the tissue is not completely restricted. When formed, the surgical fastener 130 forms a substantially "B" shaped configuration and defines an overall height "H<sub>F</sub>," measured from the backspan 134 to the outermost curve of the formed legs 132.

[0061] FIGS. 4-7 illustrate alternative configurations for the surgical fastener 130 shown in FIG. 2 that will be identified generally by the reference characters 130<sub>A</sub> (FIGS. 4, 5) and 130<sub>B</sub> (FIGS. 6, 7). The surgical fastener 130<sub>A</sub> includes a non-linear twisted backspan 134<sub>A</sub> defining one or more projections 138<sub>A</sub>, and the surgical fastener 130<sub>B</sub> includes a non-linear twisted backspan 134<sub>B</sub> defining one or more projections 138<sub>B</sub>, such that the backspans 134<sub>A</sub>, 134<sub>B</sub> are substantially non-linear in configuration. The surgical fastener backspans 134<sub>A</sub> and 134<sub>B</sub> differ in configuration in that they have different heights as described in more detail below. When formed, the substantially non-linear configuration of the twisted backspans 134<sub>A</sub>, 134<sub>B</sub> further restricts the flow of blood through the tissue surrounding the surgical fasteners 134<sub>A</sub>, 134<sub>B</sub> upon formation when compared to the substantially linear backspan 134 of the surgical fastener 130 (FIG. 2).

[0062] Referring now to FIGS. 4, 5 in particular, the backspan 134<sub>A</sub> of the surgical fastener 130<sub>A</sub> includes two projections 138<sub>A</sub> defined by the twisted configuration thereof. It should be appreciated that although the backspan has a twist that defines two projections 138<sub>A</sub>, it is also contemplated that further twists could be provided to define additional projections 138<sub>A</sub>. The projections 138<sub>A</sub> extend outwardly from the backspan 134<sub>A</sub> towards the penetrating ends 136<sub>A</sub> of the legs 132<sub>A</sub>, and define a first height "H<sub>1</sub>" that is measured from the top of the projection 138<sub>A</sub> to the outermost curve of the backspan 134<sub>A</sub>. When the surgical fastener 130<sub>A</sub> is formed within the tissue segments "T<sub>1</sub>," "T<sub>2</sub>," the projections 138<sub>A</sub> cooperate with the legs 132<sub>A</sub> of the surgical fastener 130<sub>A</sub> to apply a compressive force "F<sub>A</sub>" thereto. The compressive force "F<sub>A</sub>" applied by the surgical fastener 130<sub>A</sub> is greater than the compressive force "F" applied by surgical fastener 130 (FIG. 3), as the compressive space 140<sub>A</sub> defined between the backspan 134<sub>A</sub> and the legs 132<sub>A</sub> and occupied by the tissue segments "T<sub>1</sub>," "T<sub>2</sub>" is less in the surgical fastener 130<sub>A</sub> when compared to the compressive space 140 (FIG. 3) occupied by the tissue segments "T<sub>1</sub>," "T<sub>2</sub>" upon formation of the surgical fastener 130. Accordingly, when compared to the surgical fastener 130, the surgical fastener 130<sub>A</sub> applies greater pressure to the tissue segments "T<sub>1</sub>," "T<sub>2</sub>." Consequently, the flow of blood through the tissue surrounding the surgical fastener 130<sub>A</sub> upon formation will be more restricted when compared to the flow of blood through the tissue surrounding surgical fastener 130 upon formation, thereby further facilitating hemostasis. The dimensions of the projections 138<sub>A</sub> and the compressive space 140<sub>A</sub> occupied by the tissue segments "T<sub>1</sub>," "T<sub>2</sub>" are such that blood flow is not completely restricted, however, thereby preventing against any unnecessary necrosing of tissue. When formed, the surgical fastener 130<sub>A</sub> defines an overall height "H<sub>F</sub>" (measured from the backspan 134<sub>A</sub> to the

outermost curve of the formed legs 132<sub>A</sub>) that is substantially equal to that defined by the surgical fastener 130 (FIG. 3).

[0063] Referring now to FIGS. 6, 7, the backspan 134<sub>B</sub> of the surgical fastener 130<sub>B</sub> includes two projections 138<sub>B</sub> defined by the twisted configuration thereof. It should be appreciated that although the backspan 134<sub>B</sub> has a twist that defines two projections 138<sub>B</sub>, it is also contemplated that further twists could be provided to define additional projections 138<sub>B</sub>. The projections 138<sub>B</sub> extend outwardly from the backspan 134<sub>B</sub> towards the penetrating ends 136<sub>B</sub> of the legs 132<sub>B</sub> to define a second height "H<sub>2</sub>" that is greater than the height "H<sub>1</sub>" of the projections 134<sub>A</sub> extending outwardly from the backspan 134<sub>A</sub> of surgical fastener 130<sub>A</sub> illustrated in FIGS. 4, 5. Accordingly, when the surgical fastener 130<sub>B</sub> is formed within tissue segments "T<sub>1</sub>," "T<sub>2</sub>" (FIG. 7), the projections 138<sub>B</sub> cooperate with the legs 132<sub>B</sub> of the surgical fastener 130<sub>B</sub> to apply a compressive force "F<sub>B</sub>" thereto that is greater than the compressive forces "F" (FIG. 3), "F<sub>A</sub>" (FIG. 5) respectively applied by the surgical fasteners 130, 130<sub>A</sub>, as the compressive space 140<sub>B</sub> (FIG. 7) occupied by the tissue segments "T<sub>1</sub>," "T<sub>2</sub>" upon formation of the surgical fastener 130<sub>B</sub> is less than the compressive spaces 140 (FIG. 3) and 140<sub>A</sub> (FIG. 5) respectively occupied by the tissue segments "T<sub>1</sub>," "T<sub>2</sub>" upon formation of the surgical fasteners 130, 130<sub>A</sub>. Accordingly, when compared to the surgical fasteners 130, 130<sub>A</sub>, the surgical fastener 130<sub>B</sub> applies greater pressure to the tissue segments "T<sub>1</sub>," "T<sub>2</sub>." Consequently, the flow of blood through the tissue surrounding the surgical fastener 130<sub>B</sub> upon formation will be more restricted when compared to the flow of blood through the tissue surrounding surgical fasteners 130, 130<sub>A</sub> upon formation. The dimensions of the projections 138<sub>B</sub> and the compressive space 140<sub>B</sub> occupied by the tissue segments "T<sub>1</sub>," "T<sub>2</sub>" are such that blood flow is substantially, if not completely restricted, thereby further facilitating, and effectuating hemostasis. When formed,

the surgical fastener 130<sub>B</sub> defines an overall height "H<sub>F</sub>" that is substantially equal to those defined by the surgical fasteners 130 (FIG. 3), 130<sub>A</sub> (FIG. 5).

[0064] The surgical fasteners 130<sub>A</sub>, 130<sub>B</sub> shown in FIGS. 4-7 are substantially similar but for the dimensions of the one or more projections 138<sub>A</sub>, 138<sub>B</sub>, formed in their respective backspans 134<sub>A</sub>, 134<sub>B</sub>. The respective dimensions "H<sub>1</sub>," "H<sub>2</sub>" of the projections 138<sub>A</sub>, 138<sub>B</sub>, as well as the dimensions of the compressive spaces 140<sub>A</sub>, 140<sub>B</sub> occupied by tissue segments "T<sub>1</sub>," "T<sub>2</sub>" when the respective surgical fasteners 130<sub>A</sub>, 130<sub>B</sub> are formed, may be altered or varied in different embodiments to effectuate any desired level of hemostasis and blood flow in the tissue segments "T<sub>1</sub>," "T<sub>2</sub>" dependent upon the attributes of the tissue, e.g., the thickness thereof, or the presence of scar tissue.

[0065] FIGS. 8-10 illustrate the surgical fasteners 130, 130<sub>A</sub> installed within the cartridge body 112 shown in FIG. 1. The surgical fasteners 130, 130<sub>A</sub> are arranged within the cartridge body 112 to define a pair of first (inner) rows 142<sub>A</sub> and a pair of second (outer) rows 142<sub>B</sub> that correspond to the respective inner and outer rows 128<sub>A</sub>, 128<sub>B</sub> of fastener retention slots 126 formed in the top wall 120 (FIG. 1). Accordingly, the pair of inner rows 142<sub>A</sub> are spaced laterally from the knife slot 122, on opposite sides thereof, and the pair of outer rows 142<sub>B</sub> are spaced laterally from the pair of inner rows 142<sub>A</sub> (further away from the central longitudinal axis of the cartridge), again on opposite sides of the knife slot 122. As such, the surgical fasteners 130, 130<sub>A</sub> will be deployed on opposite sides of the cut-line (not shown) created in the tissue upon fastening. That is, the surgical fasteners 130<sub>A</sub>, which include the aforescribed projections 138<sub>A</sub> (FIGS. 4, 5), provide a greater compressive force to the tissue, since there is a shorter distance between the projections 138<sub>A</sub> and the curve of the formed legs 132, and accordingly, are provided in the inner rows 142<sub>A</sub> closer to the cut-line. The fasteners 130, which

define a greater distance between the curve of the legs 132 and the backspan 134 upon formation, are provided in the outer rows 142<sub>B</sub>, where the tissue might be thicker as a result of clamping the jaws of the surgical fastener applying apparatus 1000 (FIG. 1).

[0066] By positioning the fasteners providing greater tissue compression closer to the cut-line, i.e., the surgical fasteners 130<sub>A</sub> in the embodiment of the surgical fastener cartridge 100 illustrated in FIGS. 8-10, a greater range of tissue thicknesses can be effectively sealed by a single cartridge. It should be appreciated however, that the present disclosure also envisions that the surgical fasteners can be positioned otherwise without departing from the scope of the present disclosure. Also, while the inner and outer rows 142<sub>A</sub>, 142<sub>B</sub> are shown as including the surgical fasteners 130<sub>A</sub>, 130, respectively, the present disclosure contemplates the use of any of the surgical fasteners 130 (FIGS. 2, 3), 130<sub>A</sub> (FIGS. 4, 5), 130<sub>B</sub> (FIGS. 6, 7) disclosed herein, either exclusively, such that only a single type surgical fastener, e.g., surgical fastener 130, is present in a particular row, or in combination, such that a variety of surgical fasteners, e.g., surgical fasteners 130 and 130<sub>A</sub>, are present in the row.

[0067] As seen in FIGS. 11-14, in one embodiment, the disclosed surgical fastener cartridge 100 includes a top wall 120 having a plurality of fastener retention slots 126 arranged into a pair of first (inner) rows 128<sub>A</sub> that are spaced laterally outward from the knife slot 122, a pair of second (intermediate) rows 128<sub>B</sub> that are spaced laterally outward from the pair of inner rows 128<sub>A</sub>, and a pair of third (outer) rows 128<sub>C</sub> that are spaced laterally outward (further from the central longitudinal axis) from the pair of intermediate rows 128<sub>B</sub>, each of which is spaced on opposite sides of the knife slot 122. In this embodiment, the fasteners, e.g., the surgical fasteners 130 (FIGS. 2, 3), 130<sub>A</sub> (FIGS. 4, 5), 130<sub>B</sub> (FIGS. 6, 7) are respectively arranged within the cartridge body 112 to define a pair of first (inner) rows 142<sub>A</sub>, a pair of second (intermediate)

rows 142<sub>B</sub>, and a pair of third (outer) rows 142<sub>C</sub> that correspond to the respective inner, intermediate, and outer rows 128<sub>A</sub>, 128<sub>B</sub>, 128<sub>C</sub> of fastener retention slots 126 formed in the top wall 120 of surgical fastener cartridge 100. As with the embodiment of the surgical fastener cartridge 100 seen in FIGS. 1 and 8-10, each of the respective inner, intermediate, and outer rows 142<sub>A</sub>, 142<sub>B</sub>, 142<sub>C</sub> may comprise any of the surgical fasteners 130, 130<sub>A</sub>, 130<sub>B</sub> disclosed herein, either exclusively, such that only a single surgical fastener, e.g., surgical fastener 130, is present in a particular row, or in combination, such that a variety of surgical fasteners, e.g., surgical fasteners 130, 130<sub>A</sub>, and 130<sub>B</sub>, are present.

**[0068]** As illustrated in FIGS. 12-14, in one particular embodiment, the outer rows 142<sub>C</sub>, the intermediate rows 142<sub>B</sub>, and the inner rows 142<sub>A</sub> are comprised solely of the surgical fasteners 130, 130<sub>A</sub>, 130<sub>B</sub>, respectively, such that the flow of blood through the tissue immediately surrounding the cut-line is more restricted by the inner row 142<sub>A</sub> of surgical fasteners 130<sub>B</sub>, whereas the flow of blood through the tissue surrounding the respective intermediate and outer rows 142<sub>B</sub>, 142<sub>C</sub> is less restricted by surgical fasteners 130<sub>A</sub>, 130. Accordingly, the flow of blood will be minimized through the tissue immediately adjacent the cut-line, and will be increased gradually with the lateral distance from the cut-line. Also, by this arrangement, the surgical fasteners with the largest projections, e.g., the surgical fasteners 130<sub>B</sub>, will be positioned closest to the cut-line where the tissue is generally compressed to a greater extent, and the surgical fasteners providing for less compression, e.g., the surgical fasteners 130, which include a substantially linear backspan 134, will be positioned further from the cut-line where the tissue is generally compressed to a lesser extent. It is also contemplated that instead of a row of fasteners 130 with a linear backspan, a row of fasteners with a twisted backspan with a smaller height than the other twisted backspan fasteners can be utilized on the outer rows.

[0069] With reference now to FIGS. 1, 15, and 16, the surgical fastener applying apparatus 1000 will be discussed. The surgical fastener applying apparatus 1000 may be of either the re-usable or disposable variety, and includes a handle assembly 1002, with a movable handle 1003<sub>A</sub> and a stationary handle 1003<sub>B</sub>, that is operatively connected to a tool assembly 1004 through a distally extending elongated shaft or endoscopic portion 1006. In various embodiments, the handle assembly 1002 may be manually operated, and either additionally or alternatively, may include motorized, hydraulic, ratcheting, or other such mechanisms. In general, the tool assembly 1004 is adapted to clamp, fasten together, and sever adjacent tissue segments along a cut-line.

[0070] The tool assembly 1004 includes a second jaw 1008 that is pivotally coupled to a first jaw 1010 to facilitate approximation thereof. The second jaw 1008 of the tool assembly 1004 includes an anvil 1100, and the first jaw 1010 includes a surgical fastener cartridge assembly 1200 incorporating the aforescribed surgical fastener cartridge 100 (FIG. 1), which is loaded with a plurality of surgical fasteners, e.g., the surgical fasteners 130 (FIGS. 2, 3), the surgical fastener 130<sub>A</sub> (FIGS. 4, 5), and/or the surgical fastener 130<sub>B</sub> (FIGS. 6, 7), (FIGS. 2, 3). Pivoting the movable handle 1003<sub>A</sub> towards the stationary handle 1003<sub>B</sub> (FIG. 1) approximates the second jaw 1008 and the first jaw 1010. After the jaws 1008, 1010 are in close operative alignment clamping tissue therebetween, continued pivoting of the movable handle 1003<sub>A</sub> ejects the plurality of surgical fasteners 100 (FIG. 3) from the surgical fastener cartridge 100 such that the surgical fasteners 130, 130<sub>A</sub>, 130<sub>B</sub> are driven into the anvil 1100, thus being formed into formed surgical fasteners. The tool assembly 1004 and/or the surgical fastener cartridge assembly 1200 may comprise a removable and replaceable loading unit for the surgical fastener applying apparatus 1000.

[0071] As mentioned earlier, the surgical fastener applying apparatus 1000 includes the knife member 123. As seen in FIG. 16, the knife member 123 is operatively connected to a drive beam 1012, as described in commonly assigned U.S. Pat. No. 7,398,908, currently assigned to Tyco Healthcare Group LP. The knife member 123 may be configured and dimensioned for simultaneous engagement with both the anvil member 1100 and a cavity 1202 that is defined by the first jaw 1010.

[0072] During use, the tool assembly 1004 (FIG. 15) is first actuated to clamp onto tissue by manipulating the movable handle 1003<sub>A</sub> to advance a control rod (not shown) distally. Distal advancement of the control rod results in corresponding movement of the knife member 123 (FIG. 16), and effectuates approximation of the anvil member 1100 and the surgical fastener cartridge assembly 1200. With tissue clamped between the anvil member 1100 and the surgical fastener cartridge assembly 1200, the fasteners, e.g., the surgical fastener 130 (FIGS. 2, 3), the surgical fastener 130<sub>A</sub> (FIGS. 4, 5), and/or the surgical fastener 130<sub>B</sub> (FIGS. 6, 7), are fired from the surgical fastener applying apparatus 1000 (FIG. 1) into the tissue. The movable handle 1003<sub>A</sub> is then operated again to further advance the knife member 123 (FIG. 16).

[0073] Referring now to FIGS. 1-16, a method of fastening tissue with the surgical fastener applying apparatus 1000 (FIG. 1) will be discussed. During use, the surgical fastener applying apparatus 1000 is approximated and fired similarly to, and in accordance with other known surgical fastener applying apparatus, such as that disclosed in commonly assigned U.S. Pat. No. 5,865,361, currently assigned to Tyco Healthcare Group LP.

[0074] The movable handle 1003<sub>A</sub> (FIG. 15) is operatively connected to an actuation shaft, which receives the proximal end of a control rod, such that manipulation of the movable

handle 1003<sub>A</sub> results in linear advancement of the actuation shaft, which causes corresponding linear advancement of the control rod. An axial drive assembly is also provided that is engagable with the control rod. More specifically, the axial drive assembly includes the elongated drive beam 1012 (FIG. 16), which includes a distal end that supports the knife member 123, and a drive member that is configured and dimensioned for engagement with the control rod. As seen in FIG. 16, the knife member 123 is positioned to translate behind a sled 1204.

[0075] After the surgical fastener applying apparatus 1000 (FIG. 15) is manipulated to position the target tissue between the open jaws 1008, 1010 of the tool assembly 1004, the jaws 1008, 1010 are approximated using the handle assembly 1002 to clamp the target tissue therebetween and apply a compressive force thereto. Specifically, manipulation of the movable handle 1003<sub>A</sub> advances the actuation shaft to effectuate corresponding advancement of the control rod. Since the control rod is connected at its distal end to the drive assembly, which includes the aforementioned drive beam 1012 (FIG. 16), distal movement of the control rod causes corresponding movement of the drive beam 1012, which in turn, forces the anvil 1100 towards the surgical fastener cartridge assembly 1200.

[0076] With the tissue securely clamped between the jaws 1008, 1010 (FIG. 1), the surgical fastener applying apparatus 1000 is then fired to eject the surgical fasteners, e.g., the surgical fasteners, e.g., the surgical fastener 130 (FIGS. 2, 3), the surgical fastener 130<sub>A</sub> (FIGS. 4, 5), and/or the surgical fastener 130<sub>B</sub> (FIGS. 6, 7). To fire the surgical fastener applying apparatus 1000 (FIG. 15), the movable handle 1003<sub>A</sub> is again manipulated to cause advancement of the drive assembly, which causes the sled 1204 (FIG. 16) to traverse the cartridge body 1202, and eject the plurality of surgical fasteners 130, 130<sub>A</sub>, 130<sub>B</sub> from the surgical fastener cartridge 100 (FIG. 1). More specifically, as the sled 1204 moves distally, it engages the pushers 129

(FIGS. 8, 12, 16) to thereby drive the surgical fasteners 130, 130<sub>A</sub>, 130<sub>B</sub> upwardly, i.e., towards the top wall 120 (FIG. 1) of the surgical fastener cartridge 100. As the surgical fasteners 130, 130<sub>A</sub>, 130<sub>B</sub> are driven upwardly, the fastener retention slots 126 maintain the relative positions thereof.

[0077] After passing through the fastener retention slots 126, the surgical fasteners 130, 130<sub>A</sub>, 130<sub>B</sub> pass through the tissue and are forced into engagement with pockets 1102 formed in a tissue contacting surface 1104 of the anvil 1100, thereby achieving, for example, the formed configurations seen in FIGS. 3, 5, and 7, respectively. Upon formation within the tissue, the surgical fasteners 130, 130<sub>A</sub>, 130<sub>B</sub> limit the blood flow through the tissue immediately adjacent and surrounding the cut-line to thereby effectuate hemostasis, while permitting greater blood flow through the tissue spaced laterally therefrom to minimizing necrosing of the tissue, as discussed above.

[0078] While the tool cartridge has been discussed in connection with the surgical fastener applying apparatus 1000, which is adapted for use in laparoscopic procedures for performing surgical anastomotic fastening of tissue, the cartridge may be adapted for use with any surgical instrument suitable for the intended purpose of applying the plurality of surgical fasteners, e.g., the surgical fasteners 130, 130<sub>A</sub>, 130<sub>B</sub>, to a section of tissue, and thereafter, severing the tissue along a cut-line.

[0079] For example, the tool assembly 1004 (FIG. 1) may be adapted for use with an end-to-end anastomosis apparatus 2000 (FIG. 17), such as that disclosed in commonly assigned U.S. Pat. No. 7,455,676, currently assigned to Tyco Healthcare Group LP. The apparatus 2000 is used to simultaneously deploy a plurality of surgical fasteners arranged in substantially

annular rows. A knife is advanced with the firing of the fasteners. The apparatus 200 includes a handle assembly 2002 having a pair of actuating handle members 2004 and an approximation knob (wing nut) for moving (retracting) anvil 2016 toward cartridge 2012 containing the surgical fasteners. Cartridge 2012 is at the distal end of tubular body portion 2008 which extends from handle assembly 2002. An anvil shaft 2014 operatively couples anvil 2016 to the handle assembly 2002 such that the anvil 2016 is repositionable from a location where it is in close cooperative alignment with the fastener cartridge 2012 to a location where it is spaced apart from the fastener staple cartridge 2012.

**[0080]** The tool assembly 2010 includes a fastener ejection member that is positioned within the fastener cartridge 2012. The fastener ejection member includes a distal portion defining concentric rings of peripherally spaced staple pushers that are received within a respective staple retention slot to eject the surgical fasteners from the fastener cartridge 2012. The fastener ejection member is configured and dimensioned to be contacted by a distal end of a driver tube that is operatively connected to handle members 2004 through the body portion 2008 such that manipulation effectuates advancement of the driver tube to force the staple pushers into engagement with the plurality of surgical fasteners retained within the fastener cartridge 2012 to cause ejection of the fasteners through tissue and into contact with the anvil pockets of the anvil 2016, providing varying compressive forces on the tissue due to the varying configurations of the fastener.

**[0081]** The tool assembly 1004 (FIG. 1) may also be adapted for use with a surgical stapling apparatus 3000 (FIG. 18), such as that disclosed in commonly assigned U.S. Pat. No. 7,334,717. The surgical stapling apparatus 3000 includes a cartridge receiving half-section 3002, which accommodates a plurality of surgical fasteners arranged in a plurality of substantially

linear rows, and an anvil half-section 3004 containing a plurality of anvil pockets arranged in corresponding rows. The half-sections 3002, 3004 are pivotally connected via handles 3006, 3008 for approximation during use.

**[0082]** Following approximation of the half-sections 3002, 3004 to clamp tissue therebetween, the surgical fastener applying apparatus 3000 is fired by advancing firing mechanism 3010 distally by the advancement of a firing knob 3012. Distal movement of the firing mechanism 3010 causes a plurality of cam bars to engage camming surfaces that interact with a plurality of pushers to expel the plurality of surgical fasteners from the cartridge receiving half-section 3002 through tissue into contact with the anvil pockets of the anvil portion 3004, providing varying compressive forces on the tissue due to the varying configurations of the fasteners. The surgical fasteners are positioned on either side of a track which guides a knife during longitudinal movement to thereby sever tissue along a cut-line.

**[0083]** The tool assembly 1004 (FIG. 1) may also be adapted for use with a transverse anastomosis fastening instrument 4000 (FIG. 19), such as that disclosed in commonly owned U.S. Pat. Nos. 5,964,394 and 7,070,083. The surgical fastener applying apparatus 4000 includes an approximation lever 4001, a movable handle 4002, and an elongated portion 4004 that extends distally from the handle 4002. The cartridge 200, containing a plurality of fasteners arranged in substantially linear rows transverse to a longitudinal axis of the instrument, is supported within cartridge receiving portion 4014 of frame 4006.

**[0084]** Prior to firing of the surgical fastener applying apparatus 4000, the approximation lever 4001 is actuated to distally advance a drive member that is operatively connected to the surgical fastener cartridge 200 to move the surgical fastener cartridge 200 towards the anvil

4012, which remains stationary, and capture tissue therebetween. Thereafter, the handle 4002 is moved to advance a pusher bar distally through the elongated portion 4004 to cause corresponding movement of a head portion included at the distal end of the pusher bar. The head portion includes a plurality of fingers extending distally therefrom that are configured and dimensioned to engage the cartridge assembly to thereby eject the plurality of surgical fasteners retained therein through tissue and into contact with the anvil pockets of anvil 4012 for formation, providing varying compressive forces on the tissue due to the varying diameters. A knife can be provided in the apparatus.

**[0085]** It is also envisioned that the tool assembly 1006 (FIG. 1) may also be adapted for use with any of the other surgical fastener applying apparatus discussed in commonly owned U.S. Pat. Nos. 6,045,560; 5,964,394; 5,894,979; 5,878,937; 5,915,616; 5,836,503; 5,865,361; 5,862,972; 5,817,109; 5,797,538; and 5,782,396.

**[0086]** In additional embodiments of the present disclosure, the surgical fastener applying apparatus may include a plurality of cam bars for interacting with the pushers to deploy the surgical fasteners. For example, the surgical fastener applying apparatus disclosed in U.S. Patent No. 5,318,221 has a cam bar adapter that holds a plurality of cam bars and a knife. A channel is advanced through operation of the handle of the apparatus, which drives the cam bars and knife forward. A clamp tube that surrounds the proximal end of the anvil is advanced to clamp the anvil and cartridge together. In another example, the surgical fastener applying apparatus disclosed in U.S. Patent No. 5,782,396 has an actuation sled. An elongated drive beam is advanced distally through operation of the handle of the apparatus, driving the actuation sled forward. The distal end of the drive beam engages the anvil and the channel that supports the

cartridge as the drive beam travels distally, to deploy the staples and clamp the anvil and cartridge together.

[0087] Referring now to FIG. 20, an alternative embodiment of the surgical fastener cartridge, identified generally by the reference character 200, will be discussed. The surgical fastener cartridge 200 is substantially similar to the surgical fastener cartridge 100 discussed above, and accordingly, will only be discussed with respect to its differences therefrom.

[0088] The surgical fastener cartridge 200 is loaded with a plurality of surgical fasteners that are arranged into one or more rows, as in the case of the aforescribed surgical fastener cartridge 100. However, in contrast to the surgical fastener cartridge 100, the surgical fastener cartridge 200 does not include a knife slot for the accommodation of a knife or other such cutting element, although an alternative embodiment including a knife slot would be within the scope of the present disclosure. The surgical fastener cartridge 200 includes a plurality of fastener retention slots 226 on a top wall 220 of a cartridge body 212 that are arranged into a plurality of rows 228. The rows 228 of retention slots 226 are spaced laterally from a centerline 252 extending along the longitudinal axis "A-A" defined by cartridge body 212, and may be positioned equidistant from the sidewalls 214, 216. As shown, the plurality of rows 228 includes a pair of first (inner) rows 228<sub>A</sub> that are disposed on opposite sides of the centerline 252, and a pair of second (outer) rows 228<sub>B</sub> that are spaced laterally outward from the pair of inner rows 228<sub>A</sub>, (further from the central longitudinal axis of the cartridge), again on opposite sides of the centerline 252. Each of the fastener retention slots 226 is configured and dimensioned to receive one of a plurality of surgical fasteners, e.g., the surgical fasteners 130 (FIGS. 2, 3), 130<sub>A</sub> (FIGS. 4, 5), or 130<sub>B</sub> (FIGS. 6, 7) and pushers 129 (FIG. 8) therein such that the surgical fasteners are

deployed in rows, e.g., inner and outer rows in the embodiment of the surgical fastener cartridge 200 shown of FIG. 20, on opposite sides of the centerline 252.

**[0089]** Although the surgical fastener cartridge 200 is depicted as including pairs of first and second rows 228<sub>A</sub>, 228<sub>B</sub>, respectively, additional rows of fastener retention slots 226, and accordingly, additional rows of surgical fasteners, may be included in alternative embodiments of the surgical fastener cartridge 200, as discussed above with respect to surgical fastener cartridge 100. Also, it is envisioned that the fasteners may be arranged within the surgical fastener cartridge 200 in any of the various exemplary configurations discussed above with respect to the surgical fastener cartridge 100, for example.

**[0090]** Reference will now be made to FIGS. 21-24, which illustrate alternative configurations for the surgical fastener 130 shown in FIG. 2 that will be identified generally by the reference characters 130<sub>C</sub> (FIGS. 21, 22) and 130<sub>D</sub> (FIGS. 23, 24), that may be loaded into the surgical fastener cartridge 100 shown in FIGS. 1, 8, for example and used with the various apparatus described herein. The surgical fastener 130<sub>C</sub> includes a non-linear backspan 134<sub>C</sub> with one or more recesses 138<sub>C</sub> formed therein. The recesses 138<sub>C</sub> form curved portions extending inwardly from the backspan 134<sub>C</sub>, i.e., towards the penetrating ends 136<sub>C</sub> in the unformed condition, in arcuate fashion to define one or more humps having a first height "H<sub>1</sub>" that act to restrict the flow of blood through the tissue surrounding the surgical fastener 130<sub>C</sub>. As shown, in the formed condition of the fastener, the backspan preferably has a first curved portion opposite the curve of one of the legs and a second curved portion opposite the curve of the other fastener leg.

[0091] When the surgical fastener 130<sub>C</sub> is formed within tissue segments "T<sub>1</sub>," "T<sub>2</sub>," as seen in FIG. 22 for example, the curves (humps) 138<sub>C</sub> cooperate with the legs 132 of the surgical fastener 130<sub>C</sub> to apply a compressive force "F<sub>C</sub>" thereto. The compressive force "F<sub>C</sub>" applied by the surgical fastener 130<sub>C</sub> is greater than the compressive force "F" applied by surgical fastener 130 (FIG. 3), as the compressive space 140<sub>C</sub>, which is defined between the backspan 134<sub>C</sub> and the legs 132<sub>C</sub> and occupied by the tissue segments "T<sub>1</sub>," "T<sub>2</sub>," is less in the surgical fastener 130<sub>C</sub> when compared to the compressive space 140 (FIG. 3) occupied by the tissue segments "T<sub>1</sub>," "T<sub>2</sub>" in the surgical fastener 130. Accordingly, greater pressure is applied to the tissue segments "T<sub>1</sub>," "T<sub>2</sub>" by surgical fastener 130<sub>C</sub>. Consequently, the flow of blood through the tissue surrounding the surgical fastener 130<sub>C</sub> is more restricted when compared to the flow of blood through the tissue surrounding surgical fastener 130 (FIG. 3), thereby further facilitating hemostasis. The dimensions of the recesses/curves 138<sub>C</sub> and the compressive space 140<sub>C</sub> occupied by the tissue segments "T<sub>1</sub>," "T<sub>2</sub>" are such that blood flow is not completely restricted, however, thereby preventing any unnecessary necrosis of tissue. When formed, the surgical fastener 130<sub>C</sub> defines an overall height "H<sub>F</sub>" (measured from the backspan 134<sub>C</sub> to the outermost curved of the formed legs 132<sub>C</sub>) that is substantially equal to that defined by the surgical fastener 130 (FIG. 3).

[0092] With particular reference to FIGS. 23 and 24, an alternative embodiment of the surgical fastener, identified generally by the reference character 130<sub>D</sub>, is shown in its formed condition. The surgical fastener 130<sub>D</sub> is similar to the surgical fastener 130<sub>C</sub> discussed above with respect to FIGS. 21 and 22, in that the surgical fastener 130<sub>D</sub> includes a pair of recesses/curves 138<sub>D</sub> formed in the backspan 134<sub>D</sub> defining a pair of humps or curves. However, the recesses/curves 138<sub>D</sub> formed in the backspan 134<sub>D</sub> of the surgical fastener 130<sub>D</sub> define a

height "H<sub>2</sub>" that is greater than the height "H<sub>1</sub>" of the humps or recesses 138<sub>C</sub> formed in the backspan 134<sub>C</sub> of the surgical fastener 130<sub>C</sub> illustrated in FIGS. 21 and 22. Accordingly, when the surgical fastener 130<sub>D</sub> is formed within tissue segments "T<sub>1</sub>," "T<sub>2</sub>," the recesses/curves 138<sub>D</sub> cooperate with the legs 132<sub>D</sub> of the surgical fastener 130<sub>D</sub> to apply a compressive force "F<sub>D</sub>" thereto. The compressive force "F<sub>D</sub>" applied by the surgical fastener 130<sub>D</sub> is greater than the compressive forces "F," "F<sub>C</sub>" respectively applied by the surgical fasteners 130 (FIG. 2, 3), 130<sub>C</sub> (FIGS. 21, 22), as the compressive space 140<sub>D</sub> occupied by the tissue segments "T<sub>1</sub>," "T<sub>2</sub>" is less in the surgical fastener 130<sub>D</sub> when compared to the compressive spaces 140 (FIG. 3), 140<sub>C</sub> (FIG. 22) respectively occupied by the tissue segments "T<sub>1</sub>," "T<sub>2</sub>" in the surgical fasteners 130, 130<sub>C</sub>. Accordingly, greater pressure is applied to the tissue segments "T<sub>1</sub>," "T<sub>2</sub>" by the surgical fastener 130<sub>D</sub>. Consequently, the flow of blood through the tissue surrounding the surgical fastener 130<sub>D</sub> is more restricted when compared to the flow of blood through the tissue surrounding surgical fasteners 130 (FIG. 3), 130<sub>C</sub> (FIGS. 21, 22). The dimensions of the recesses/curves 138<sub>D</sub> and the compressive space 140<sub>D</sub> occupied by the tissue segments "T<sub>1</sub>," "T<sub>2</sub>" are such that blood flow is substantially, if not completely restricted, thereby further facilitating, and effectuating hemostasis. When formed, the surgical fastener 130<sub>D</sub> defines an overall height "H<sub>F</sub>" that is substantially equal to those defined by the surgical fasteners 130 (FIG. 3), 130<sub>C</sub> (FIG. 22).

[0093] The surgical fasteners 130<sub>C</sub> (FIG. 21, 22), 130<sub>D</sub> (FIGS. 23, 24) are substantially similar in configuration but for the dimensions of the hump(s) (curves) formed by the recesses 138<sub>C</sub>, 138<sub>D</sub> formed in their respective backspans 134<sub>C</sub>, 134<sub>D</sub>. The respective dimensions "H<sub>1</sub>," "H<sub>2</sub>" of the recesses/curves 138<sub>C</sub>, 138<sub>D</sub>, as well as the dimensions of the compressive spaces 140<sub>C</sub>, 140<sub>D</sub> occupied by tissue segments "T<sub>1</sub>," "T<sub>2</sub>" when the respective surgical fasteners 130<sub>C</sub>, 130<sub>D</sub> are in their formed conditions, may be altered or varied in different embodiments to

effectuate a desired level of hemostasis and blood flow in the tissue segments "T<sub>1</sub>," "T<sub>2</sub>" dependent upon various attributes of the tissue, e.g., thickness or the presence of scar tissue.

[0094] FIGS. 25 and 26 illustrate the surgical fasteners 130 (FIG. 3) and 130<sub>C</sub> (FIGS. 21, 22) installed within the cartridge body 112 seen in FIG. 1. The surgical fasteners 130<sub>C</sub>, 130 are arranged within the cartridge body 112 to define a pair of first (inner) rows 142<sub>A</sub> and a pair of second (outer) rows 142<sub>B</sub> that correspond to the respective inner and outer rows 128<sub>A</sub>, 128<sub>B</sub> of fastener retention slots 126 formed in the top wall 120 (FIG. 1). Accordingly, the pair of inner rows 142<sub>A</sub> is spaced laterally outward from the knife slot 122, on opposite sides thereof, and the pair of outer rows 142<sub>B</sub> are spaced laterally outward from the pair of inner rows 142<sub>A</sub>, again on opposite sides of the knife slot 122 and further from a central longitudinal axis of the cartridge. As such, the surgical fasteners 130, 130<sub>C</sub> will be deployed on opposite sides of the cut-line (not shown) created in the tissue upon fastening. That is, the surgical fasteners 130<sub>C</sub>, which include the aforescribed projections or curves 138<sub>C</sub> (FIGS. 20, 21), provide a greater compressive force to the tissue, since there is a shorter distance between the projections 138<sub>C</sub> and the curve of the formed legs 132, and accordingly, are provided in the inner rows 142<sub>A</sub> closer to the cut-line. The fasteners 130, which define a greater distance between the curve of the legs 132 and the backspan 134 upon formation, are provided in the outer rows 142<sub>B</sub>, where the tissue might be thicker as a result of clamping the jaws of the apparatus, e.g. the surgical fastener applying apparatus 1000 (FIG. 1).

[0095] By positioning the fasteners providing greater tissue compression closer to the cut-line, i.e., the surgical fasteners 130<sub>C</sub> in the embodiment of the surgical fastener cartridge 100 illustrated in FIGS. 24 and 25, a greater range of tissue thicknesses can be effectively sealed by a single surgical fastener cartridge. It should be appreciated however, that the present disclosure

also envisions that the surgical fasteners can be positioned otherwise without departing from the scope of the present disclosure. Also, while the inner and outer rows 142<sub>A</sub>, 142<sub>B</sub> are shown as including the surgical fasteners 130<sub>C</sub>, 130, respectively, the present disclosure contemplates the use of any of the surgical fasteners 130 (FIGS. 2, 3), 130<sub>A</sub> (FIGS. 4, 5), 130<sub>B</sub> (FIGS. 6, 7), 130<sub>C</sub> (FIGS. 20, 21), 130<sub>C</sub> (FIGS. 22, 23) disclosed herein above, either exclusively, such that only a single type surgical fastener, e.g., surgical fastener 130, is present in a particular row, or in combination, such that a variety of surgical fasteners, e.g., surgical fasteners 130 and 130<sub>C</sub>, are present.

[0096] FIGS. 27 and 28 illustrate another embodiment of the present disclosure in which the cartridge body 112, shown in FIG. 1, may be loaded with the surgical fasteners 130 (FIG. 3), 130<sub>C</sub> (FIGS. 21, 22), and 130<sub>D</sub> (FIGS. 23, 24). In this embodiment, as with the embodiment seen in FIGS. 1 and 11-14 and discussed above, the disclosed surgical fastener cartridge 100 includes a top wall 120 having a plurality of fastener retention slots 126 arranged into a pair of first (inner) rows that are spaced laterally from the knife slot 122, a pair of second (intermediate) rows that are spaced laterally from the pair of inner rows, and a pair of third (outer) rows that are spaced laterally from the pair of intermediate rows, each of which is spaced on opposite sides of the knife slot 122. Accordingly, the fasteners, e.g., surgical fasteners 130, 130<sub>C</sub>, 130<sub>D</sub> are arranged within the cartridge body 112 to define a pair of first (inner) rows 142<sub>A</sub>, a pair of second (intermediate) rows 142<sub>B</sub>, and a pair of third (outer) rows 142<sub>C</sub> that correspond to the respective inner, intermediate, and outer rows 128<sub>A</sub>, 128<sub>B</sub>, 128<sub>C</sub> of fastener retention slots 126 formed in the top wall 120 of surgical fastener cartridge 100. In this embodiment, as with the embodiment of FIGS. 1 and 11-14, each of the respective inner, intermediate, and outer rows 142<sub>A</sub>, 142<sub>B</sub>, 142<sub>C</sub> may comprise any of the surgical fasteners 130, 130<sub>C</sub>, 130<sub>D</sub> disclosed herein,

either exclusively, such that only a single type surgical fastener, e.g., surgical fastener 130, is present in a particular row, or in combination, such that a variety of surgical fasteners, e.g., surgical fasteners 130, 130<sub>C</sub>, and 130<sub>D</sub>, are present. In the particular embodiment shown in FIGS. 27 and 28, however, the respective outer, intermediate, and inner rows 142<sub>C</sub>, 142<sub>B</sub>, and 142<sub>A</sub> are comprised solely of the surgical fasteners 130, 130<sub>C</sub>, 130<sub>B</sub>, such that the flow of blood through the tissue immediately surrounding the cut-line is more restricted by the inner row 142<sub>A</sub> of surgical fasteners 130<sub>D</sub>, whereas the flow of blood through the tissue surrounding the respective intermediate and outer rows 142<sub>B</sub>, 142<sub>C</sub>, respectively, is less restricted by the surgical fasteners 130<sub>C</sub>, 130, respectively. Accordingly, the flow of blood will be minimized in the tissue immediately adjacent the cut-line, and will be increased gradually with the lateral distance from the cut-line. Also, by this arrangement, the surgical fasteners with the largest curved portions/recesses, e.g., the surgical fasteners 130<sub>D</sub>, will be positioned closest to the cut-line where the tissue is generally compressed to a greater extent, and the surgical fasteners providing for less compression, e.g., the surgical fasteners 130, which include a substantially linear backspan 134, as described above, will be positioned further from the cut-line where the tissue is generally compressed to a lesser extent.

[0097] The above description, disclosure, and figures should not be construed as limiting, but merely as exemplary of particular embodiments. It is to be understood, therefore, that the disclosure is not limited to the precise embodiments described, and that various other changes and modifications may be effected by one skilled in the art.

Additionally, those skilled in the art will appreciate that the elements and features illustrated or described in connection with one embodiment can be combined with those

of another, and that such modifications and variations are also intended to be included within the scope of the present disclosure.

The embodiments of the present invention for which an exclusive property or privilege is claimed are defined as follows:

1. A surgical fastener applying apparatus comprising a first jaw and a second jaw, the first jaw including a cartridge body having a plurality of surgical fasteners disposed therein, the plurality of surgical fasteners including a plurality of first surgical fasteners having a first backspan with a first configuration, and a plurality of second surgical fasteners having a second backspan with a second configuration, wherein the first configuration is different than the second configuration such that the plurality of first surgical fasteners apply a first compressive force to tissue upon formation, and the plurality of second surgical fasteners apply a second, different compressive force to tissue upon formation, wherein the backspan of the plurality of first surgical fasteners has a twisted configuration defining a first height, and the backspan of the plurality of second surgical fasteners has a twisted configuration defining a second height, the first height being greater than the second height.

2. The surgical fastener applying apparatus of claim 1, wherein the plurality of first surgical fasteners are arranged in a first row, and the plurality of second surgical fasteners are arranged in a second row laterally outward of the first row, and the first and second backspans of the first and second fasteners are configured and dimensioned such that the first compressive force is greater than the second compressive force.

3. The surgical fastener applying apparatus of claim 1 or 2, wherein the cartridge body includes a channel configured to accommodate a cutting member for the creation of a cut-line in the tissue.

4. The surgical fastener applying apparatus of claim 2 or 3, further comprising a plurality of third fasteners arranged in a third row laterally outward of the plurality of second fasteners arranged in the second row, the third fasteners having a third backspan with a third configuration different than at least one of the respective first and second configurations of the first and second backspans.

5. The surgical fastener applying apparatus of claim 4, wherein the third configuration is different than both of the respective first and second configurations of the first and second backspans, the third fasteners applying a third compressive force to the tissue upon formation, the third compressive force being less than the first compressive force and less than the second compressive force.

6. The surgical fastener applying apparatus of claim 5, wherein the plurality of third fasteners have a third backspan having a twisted configuration defining a third height less than a first height of the first backspan.

7. The surgical fastener applying apparatus of claim 1 or 6, wherein the backspan includes multiple twists such that at least two portions of the backspan extend toward penetrating ends of the plurality of surgical fasteners.

8. The surgical fastener applying apparatus of claim 4 or 5, wherein the third backspan of the plurality of third surgical fasteners is substantially linear in configuration.

9. The surgical fastener applying apparatus of any one of claims 1 to 8, wherein the first surgical fasteners and the second surgical fasteners define a substantially equivalent overall height when formed.

10. The surgical fastener applying apparatus of any one of claims 1 to 3, wherein the first surgical fasteners include legs extending from the first backspan and terminating in penetrating ends, the first backspan including at least one first curve extending towards the penetrating ends and dimensioned to define a first height.

11. The surgical fastener applying apparatus of claim 10, wherein the second surgical fasteners include legs extending from the second backspan and terminating in penetrating ends, the second backspan including at least one curve extending towards the penetrating ends and dimensioned to define a second height less than the first height.

12. The surgical fastener applying apparatus of claim 11, further comprising a plurality of third surgical fasteners having legs extending from a third backspan and terminating in penetrating ends, the third backspan dimensioned to define a third height, the third height being less than the second height.

13. The surgical fastener applying apparatus of claim 11 or 12, wherein the first backspan and the second backspan have a curve positioned opposite the curve of each of the legs in a formed condition of the fastener.

14. The surgical fastener applying apparatus of any one of claims 1 to 13, wherein the first and second rows are substantially linear.

15. The surgical fastener applying apparatus of any one of claims 1 to 13, wherein the first and second rows are substantially annular.

16. The surgical fastener applying apparatus of any one of claims 1 to 15, wherein the first and second jaws are pivotally attached.

17. The surgical fastener applying apparatus of any one of claims 1 to 16, wherein at least one of the first and second jaws are movable in a substantially linear direction to move the jaws to an approximated position to clamp tissue therebetween.

18. A surgical fastener cartridge comprising a cartridge body including a plurality of surgical fasteners disposed therein, the plurality of surgical fasteners including a plurality of first surgical fasteners arranged in a first row and having a first backspan with a first configuration, and a plurality of second surgical fasteners arranged in a second row and having a second backspan with a second configuration, wherein the first backspan has a first height and the second backspan has a second height, the first height being less than the second height, wherein the first and second backspans have a twisted configuration and the first surgical fasteners apply a first compressive force to tissue upon formation, and the second surgical fasteners apply a second, lesser compressive force to tissue upon formation.

19. The cartridge of claim 18, wherein the first surgical fasteners include first legs extending from the first backspan and terminating in penetrating ends and the second surgical fasteners include second legs extending from the second backspan and terminating in penetrating ends, wherein the first backspan includes at least one portion curving inwardly toward the penetrating ends of the first legs to form a humped configuration to define the first height, and the second backspan includes at least one portion curving inwardly toward the penetrating ends of the second legs to form a humped configuration to define the second height.

20. The cartridge of claim 18 or 19, wherein the cartridge includes a central longitudinal axis and the second fastener row is disposed further from the central longitudinal axis than the first fasteners.

21. The cartridge of any one of claims 18 to 20, further comprising a plurality of third surgical fasteners having a third backspan with a third configuration such that the plurality of third surgical fasteners apply a third compressive force to the tissue upon formation that is different from at least one of the first compressive force and the second compressive force respectively applied to tissue by the plurality of first surgical fasteners and the plurality of second surgical fasteners upon formation, the third fasteners being disposed further from a central longitudinal axis of the cartridge than the second fasteners.

22. The cartridge of any one of claims 18 to 21, wherein the first backspan of the first surgical fasteners and the second backspan of the second surgical fasteners are dimensioned such that the first compressive force is greater than the second compressive force.

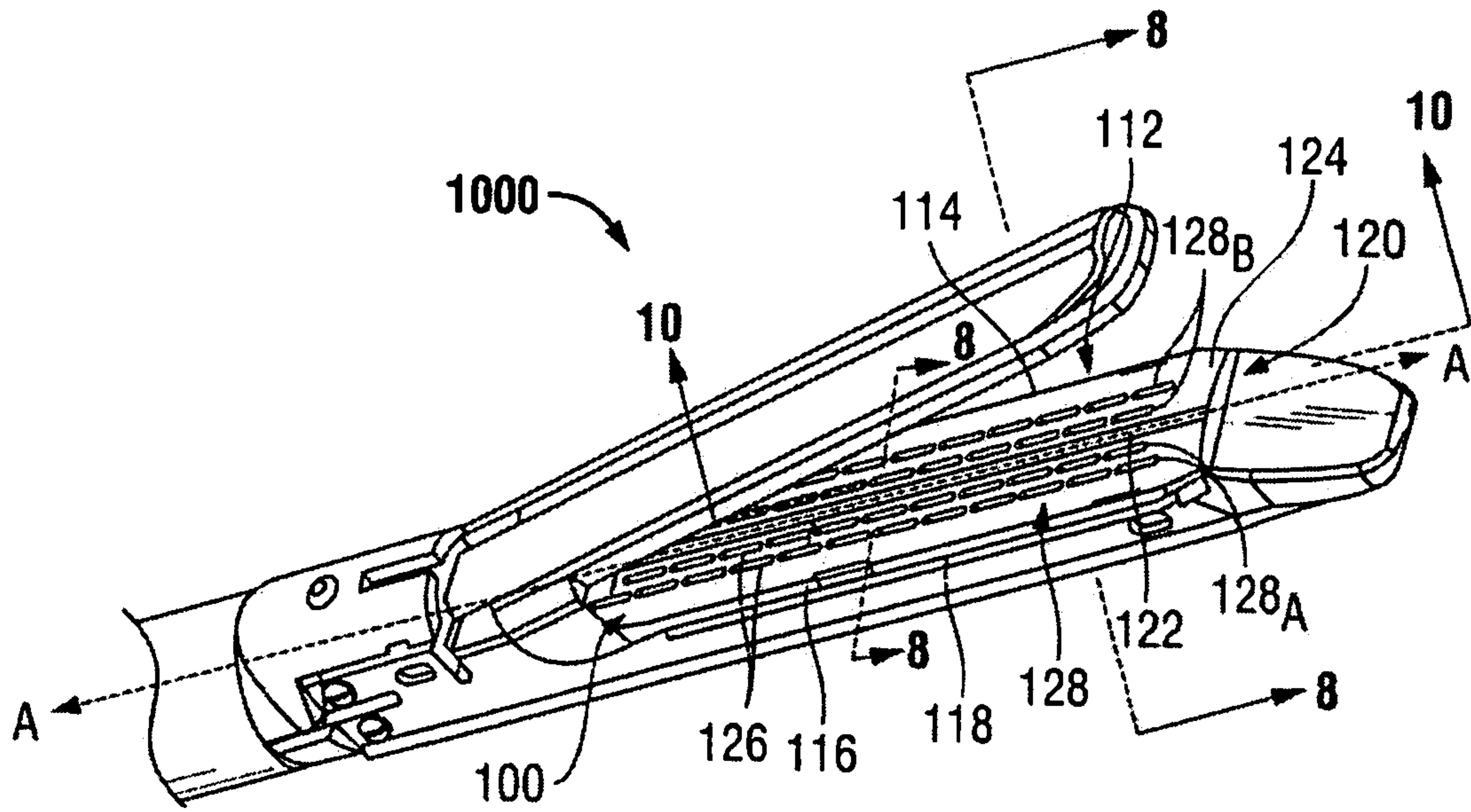

FIG. 1

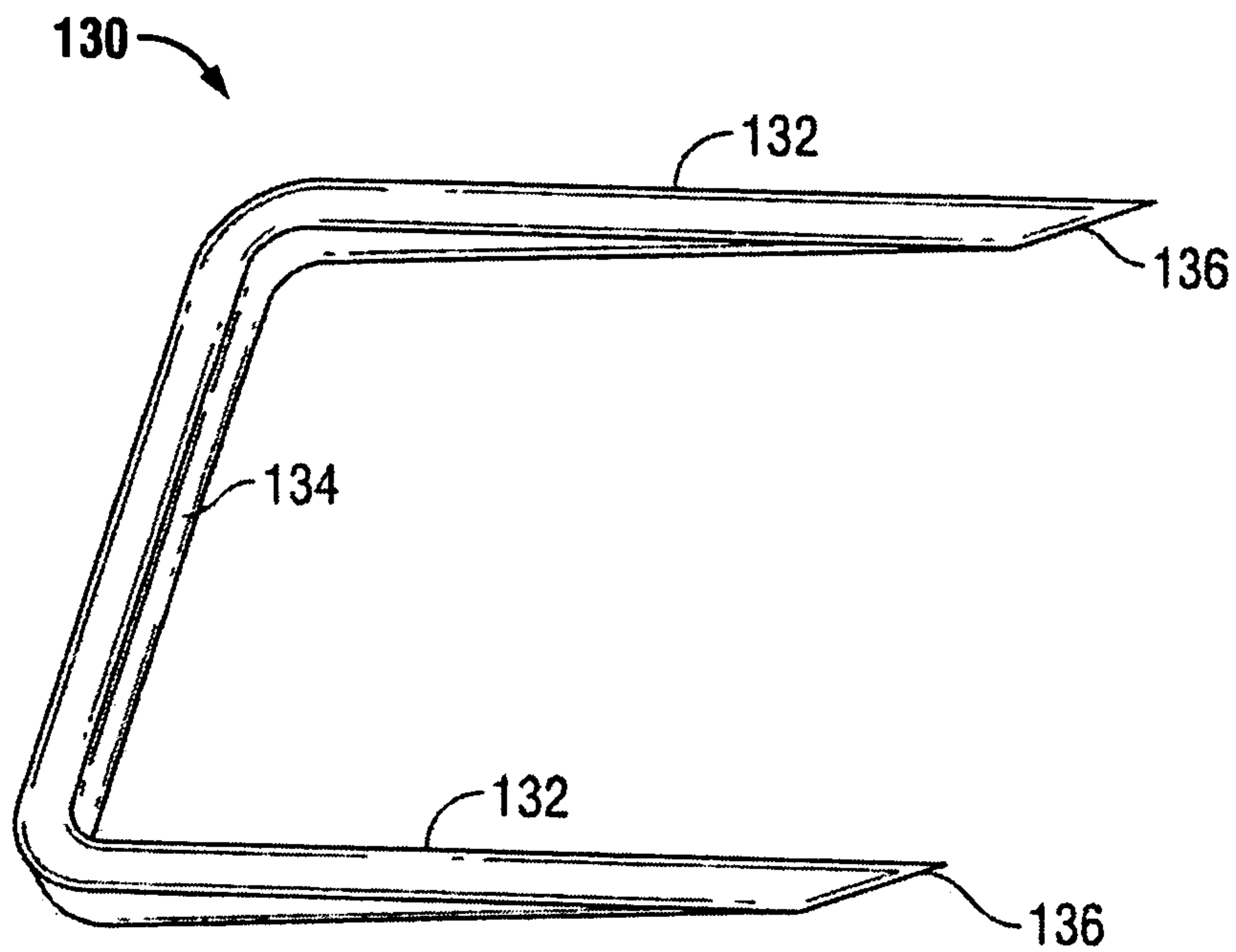

FIG. 2

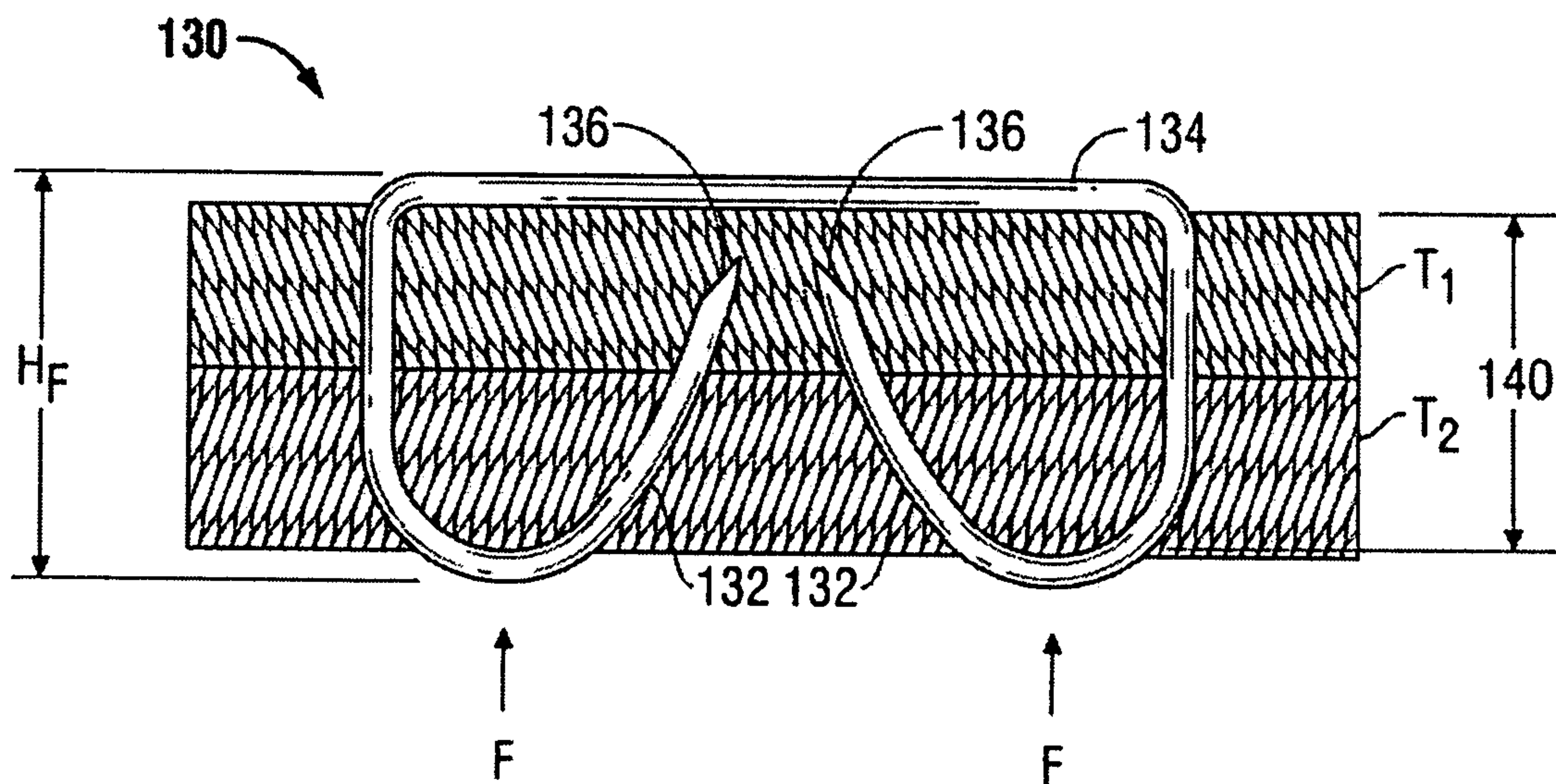

FIG. 3

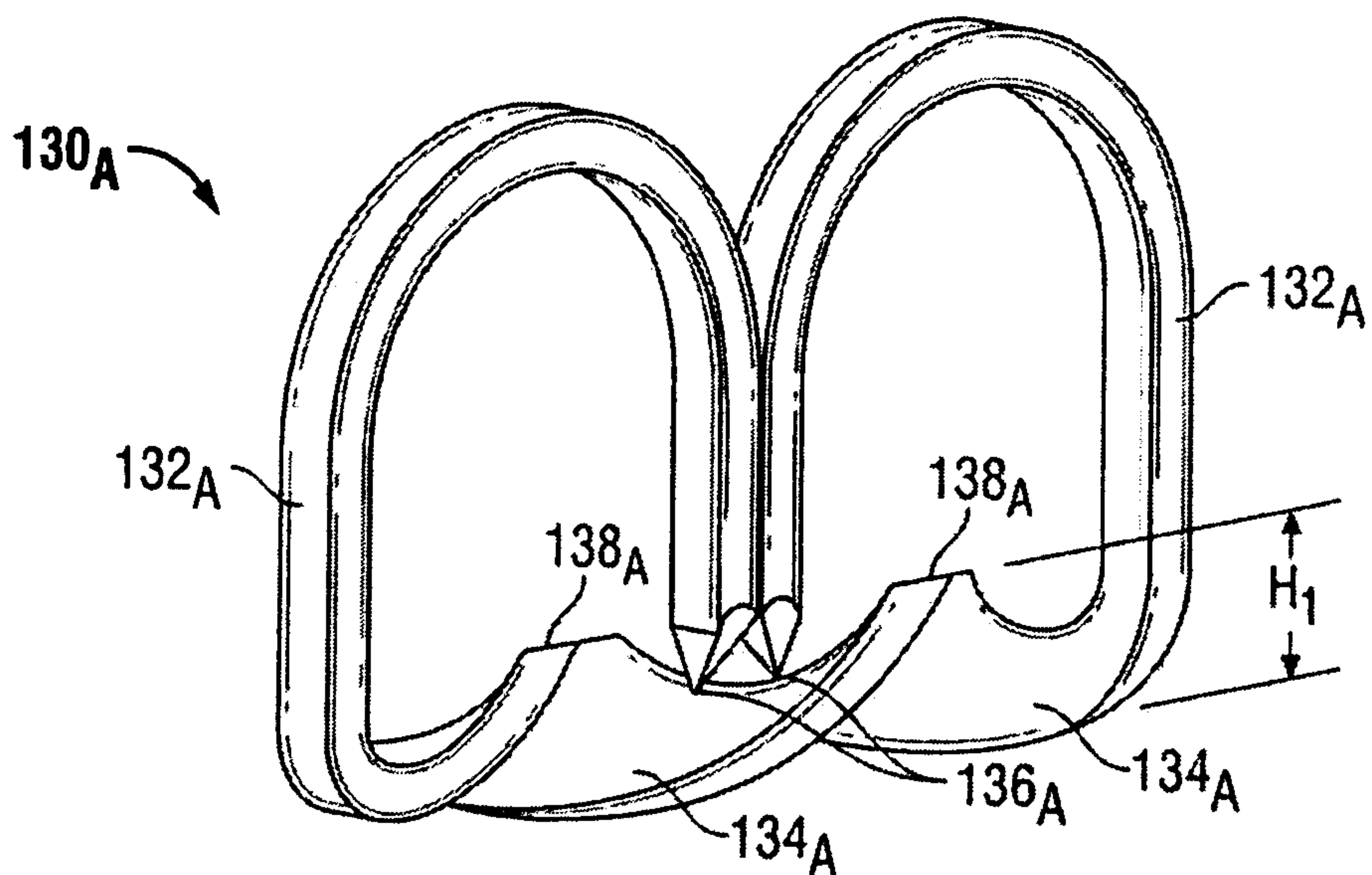

FIG. 4

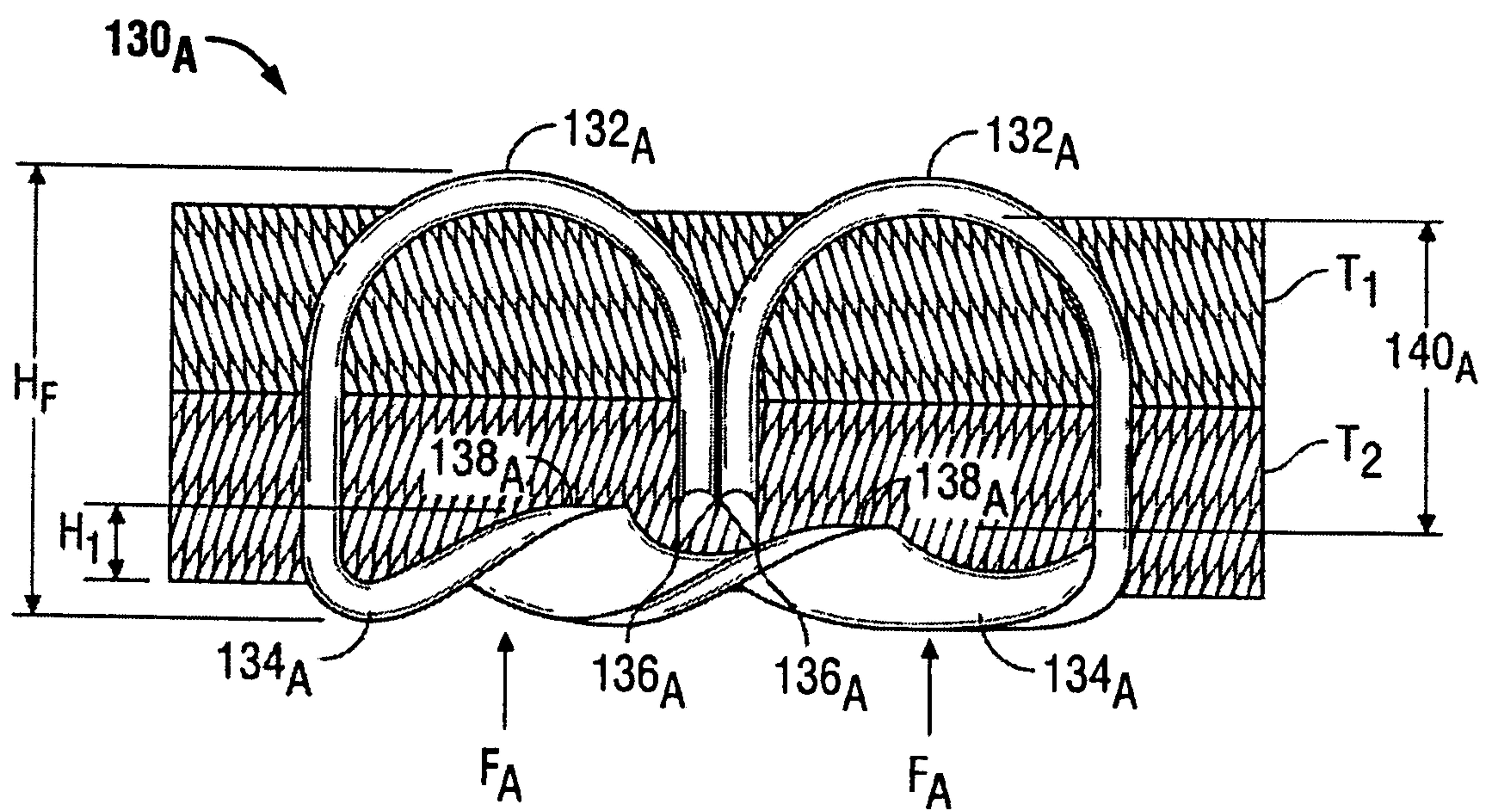

FIG. 5

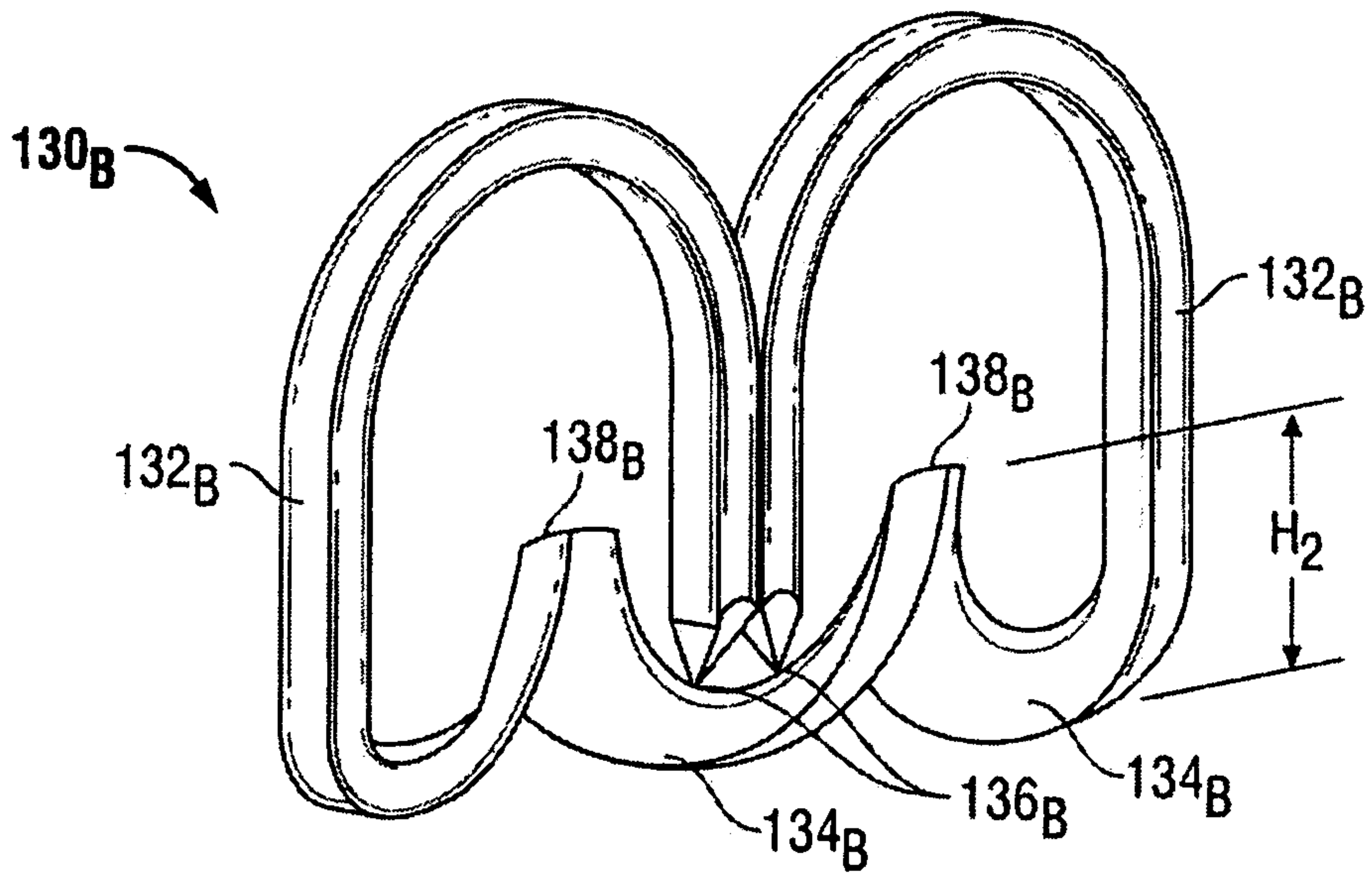

FIG. 6

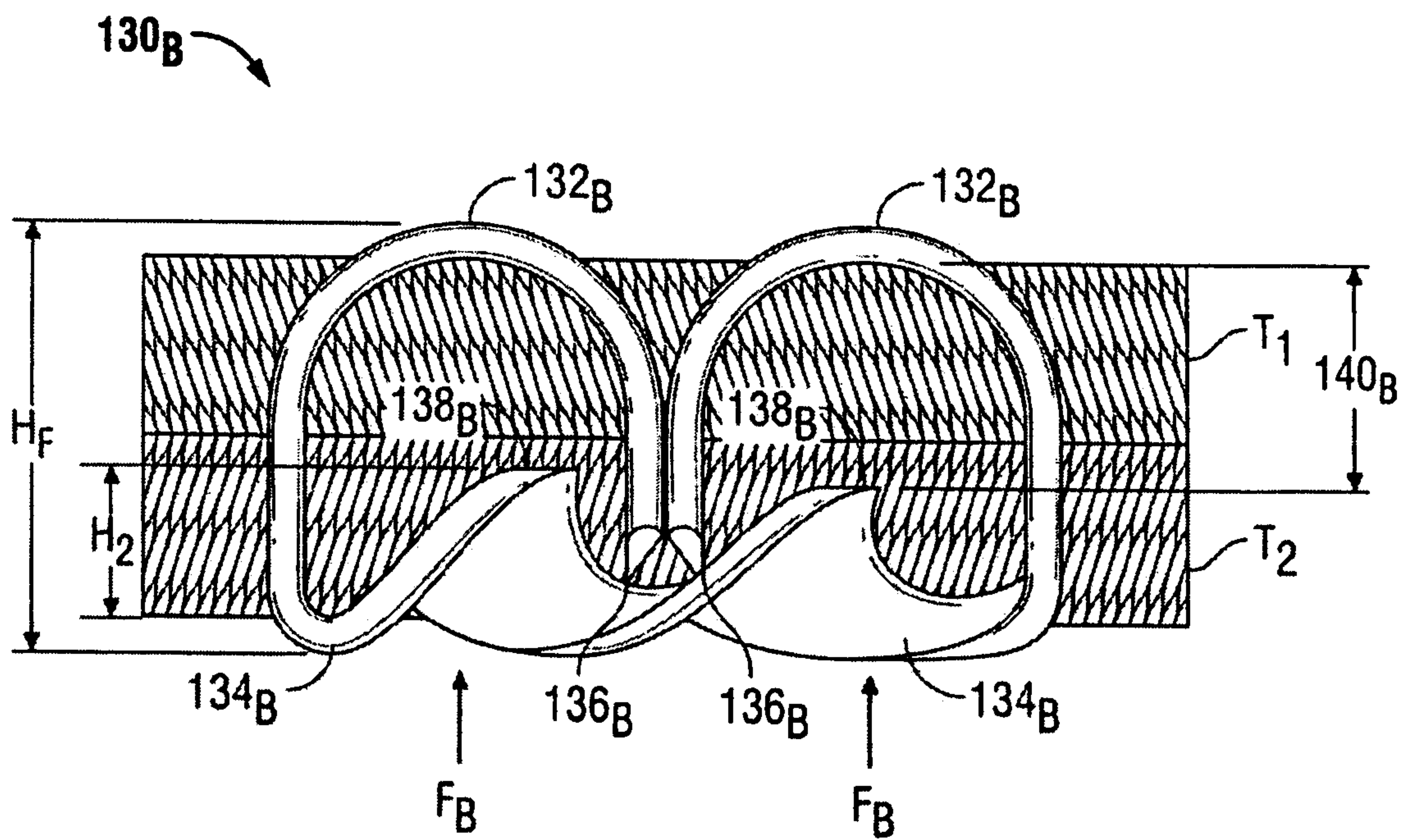

FIG. 7

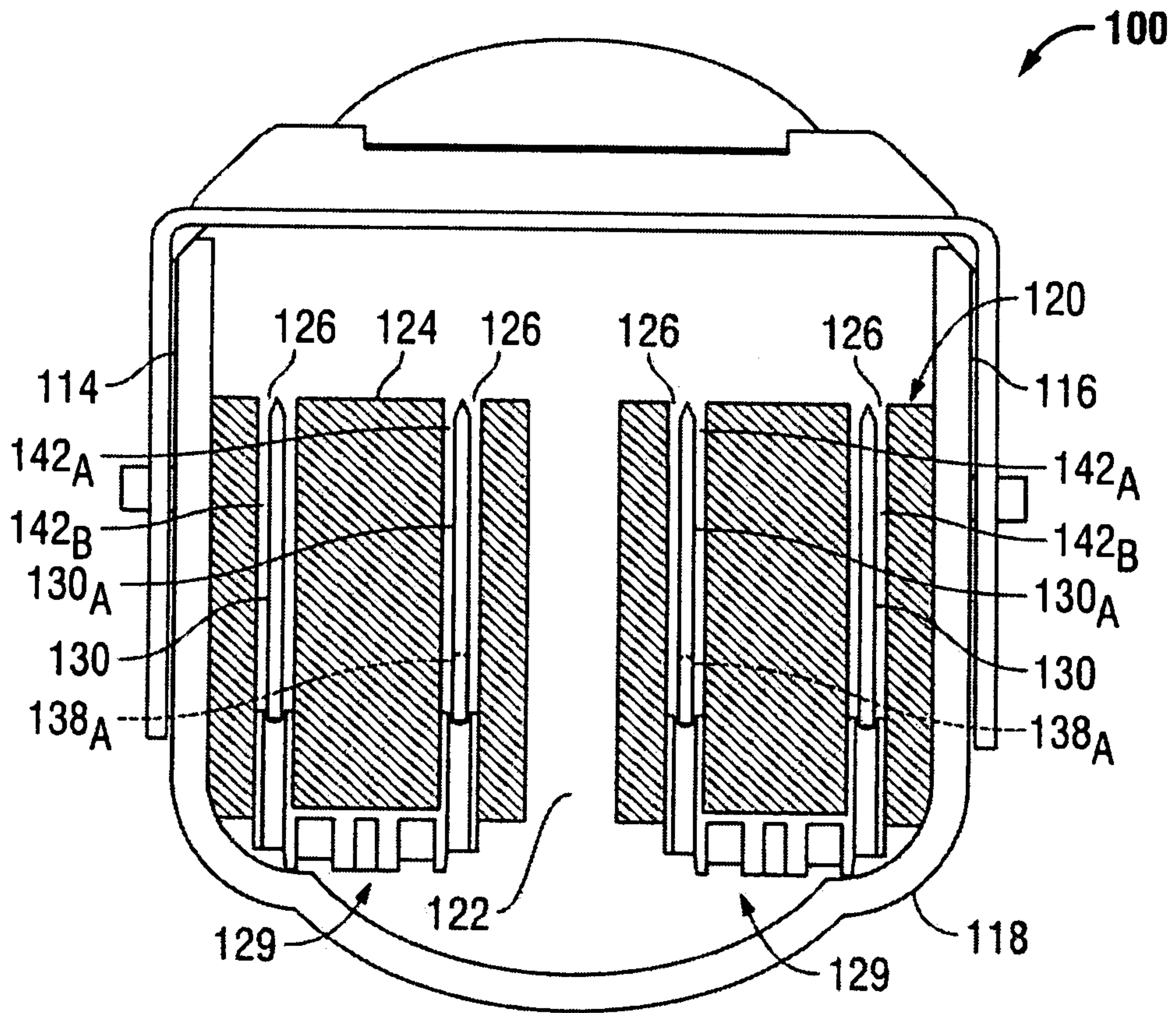

FIG. 8

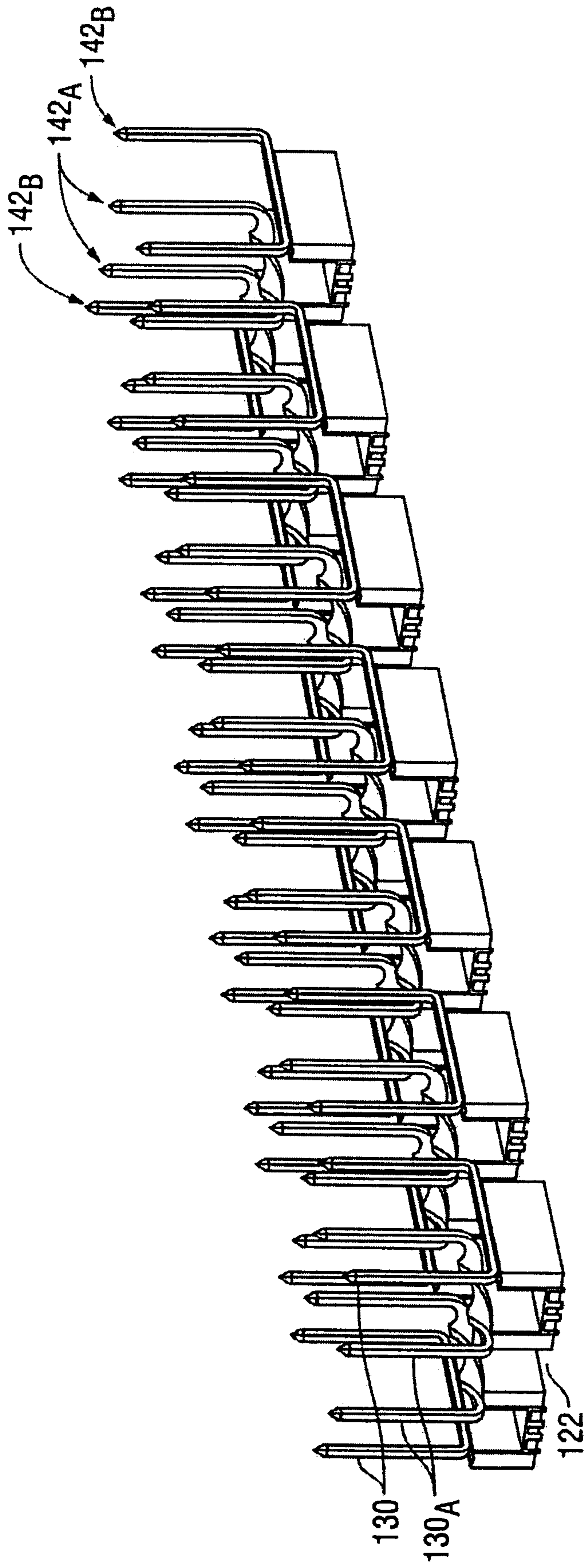
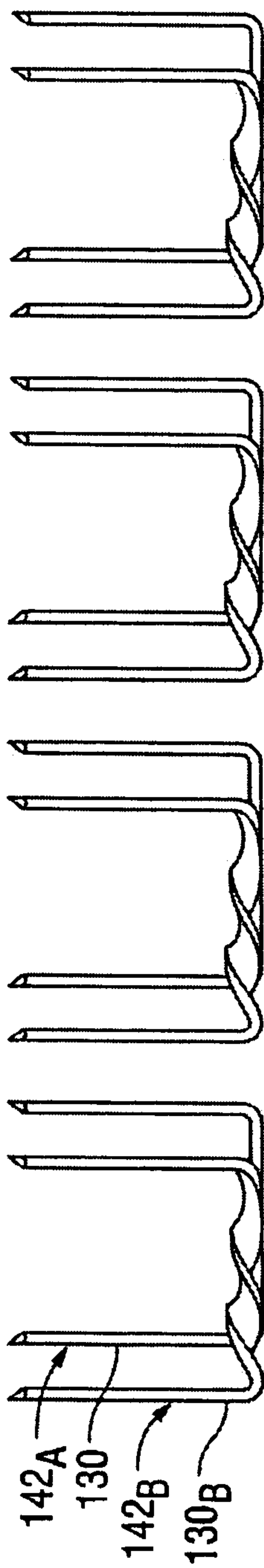

FIG. 9



**FIG. 10**

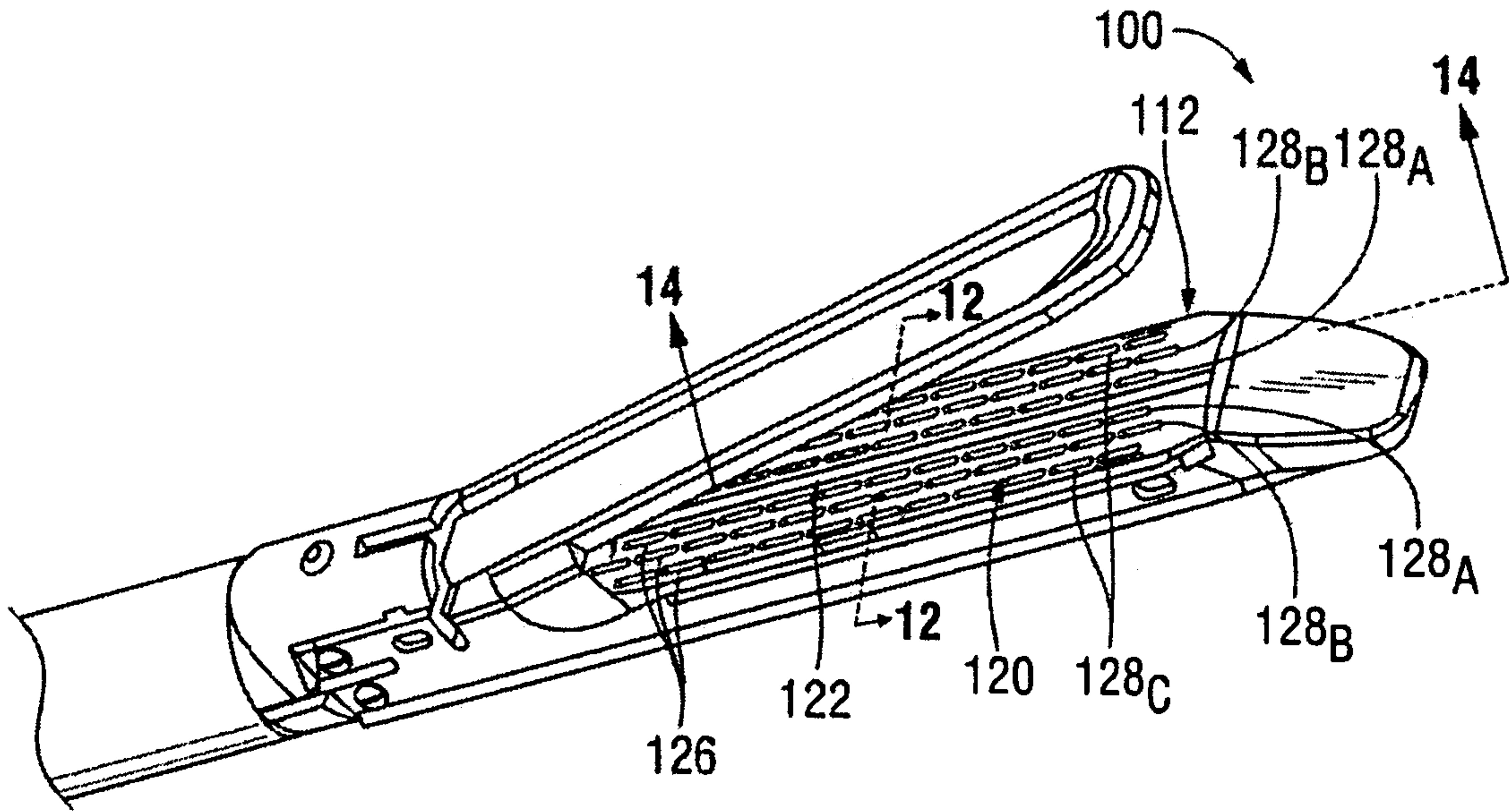

FIG. 11

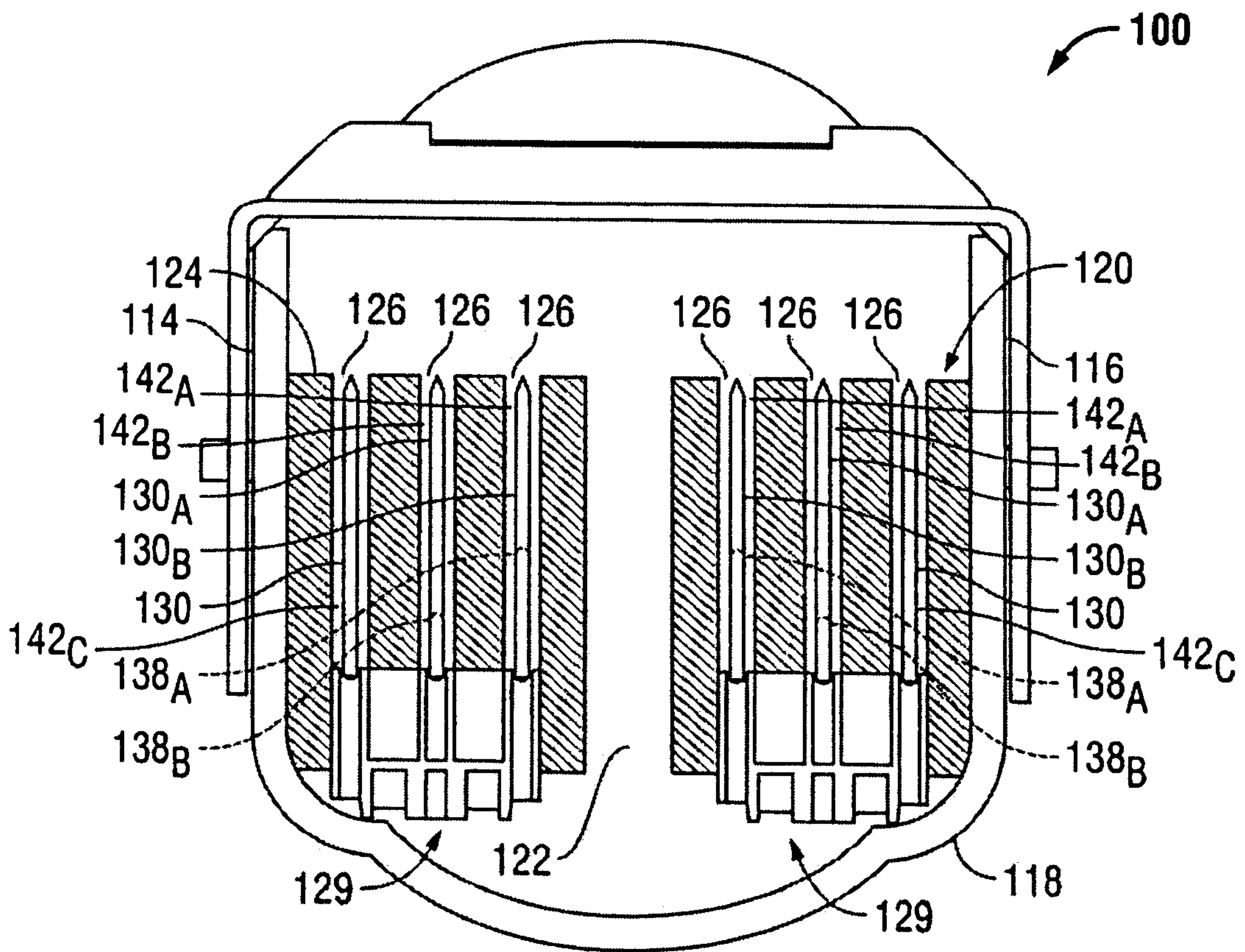

FIG. 12

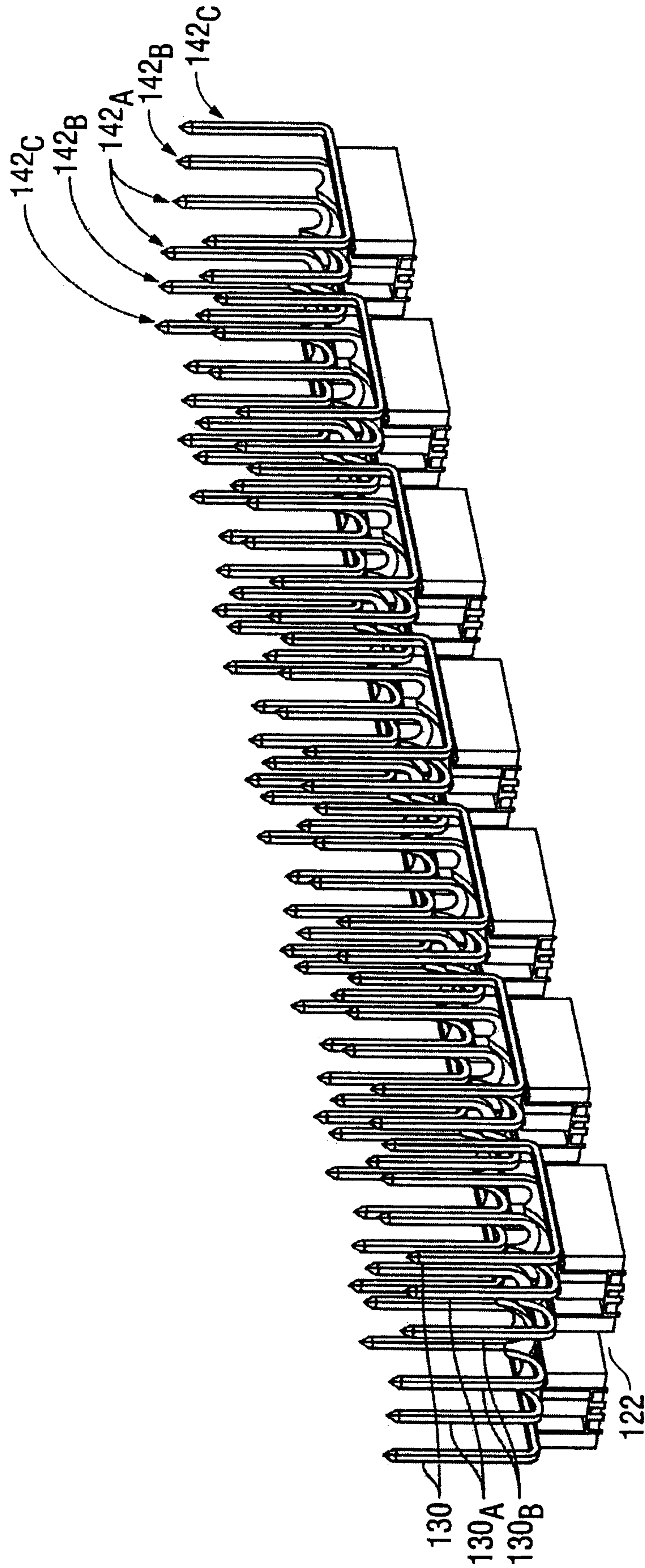
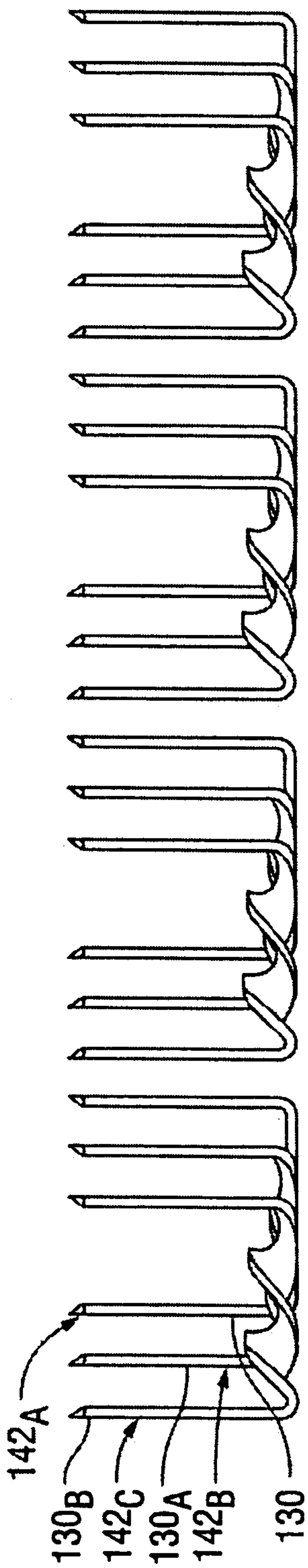
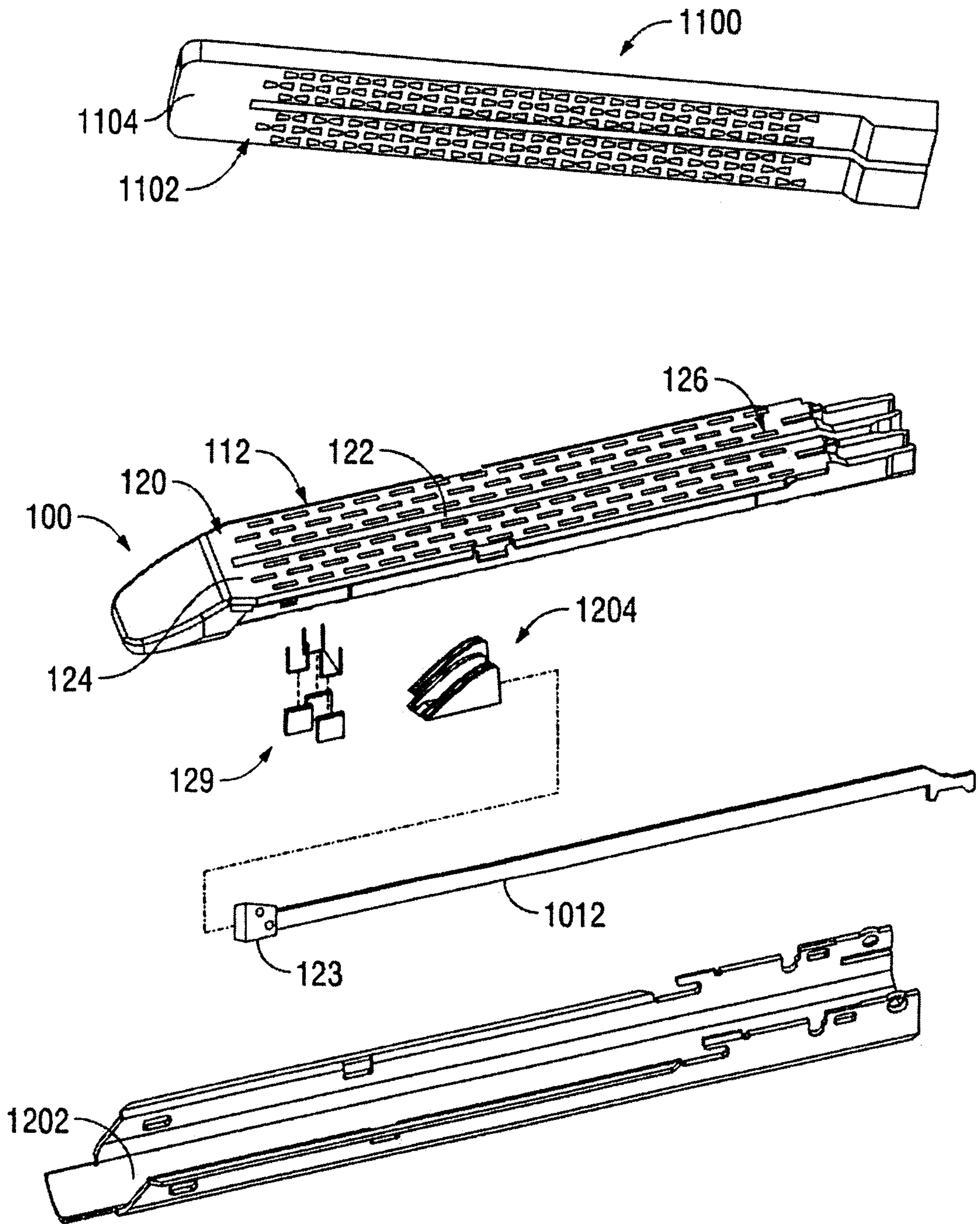

FIG. 13

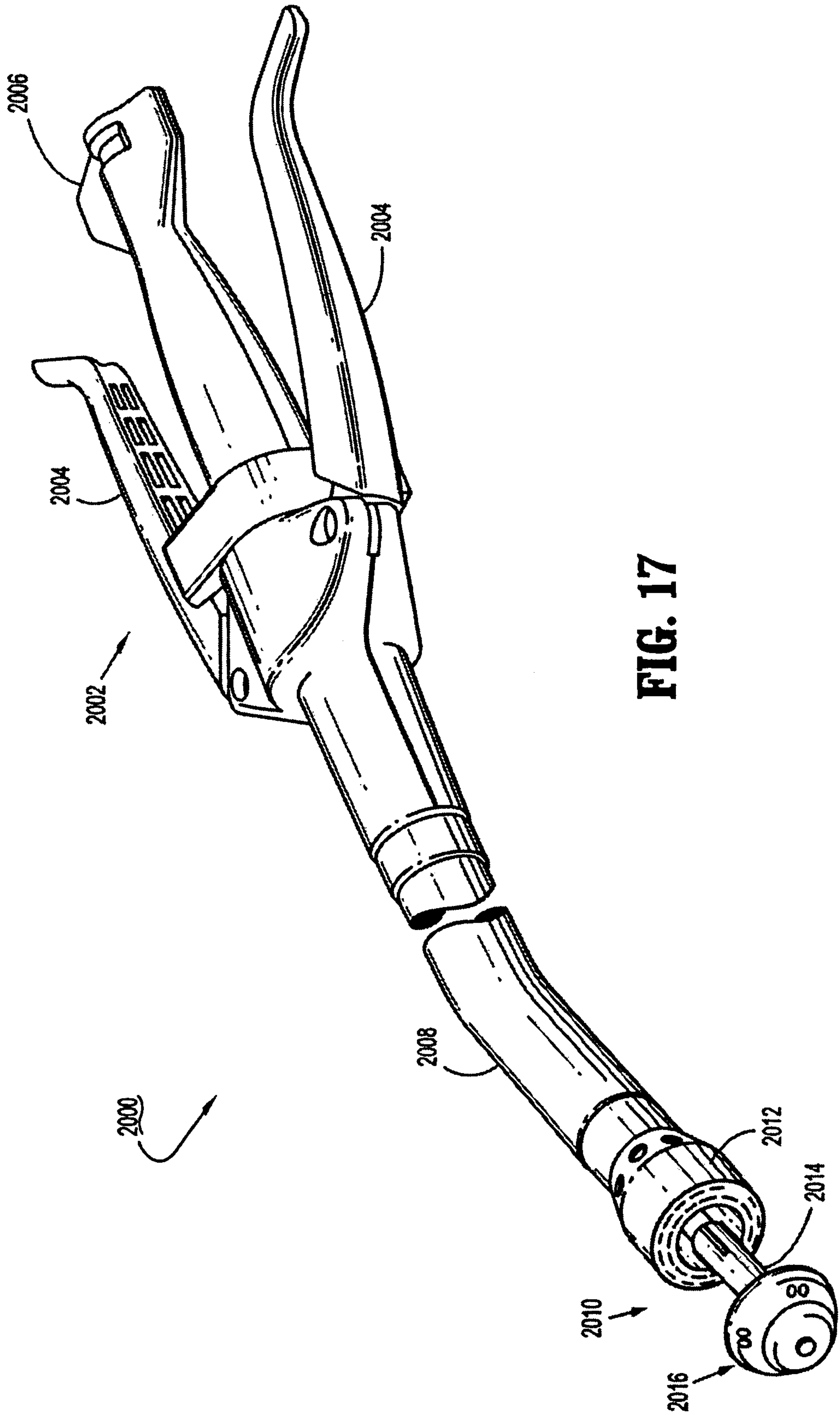

**FIG. 14**

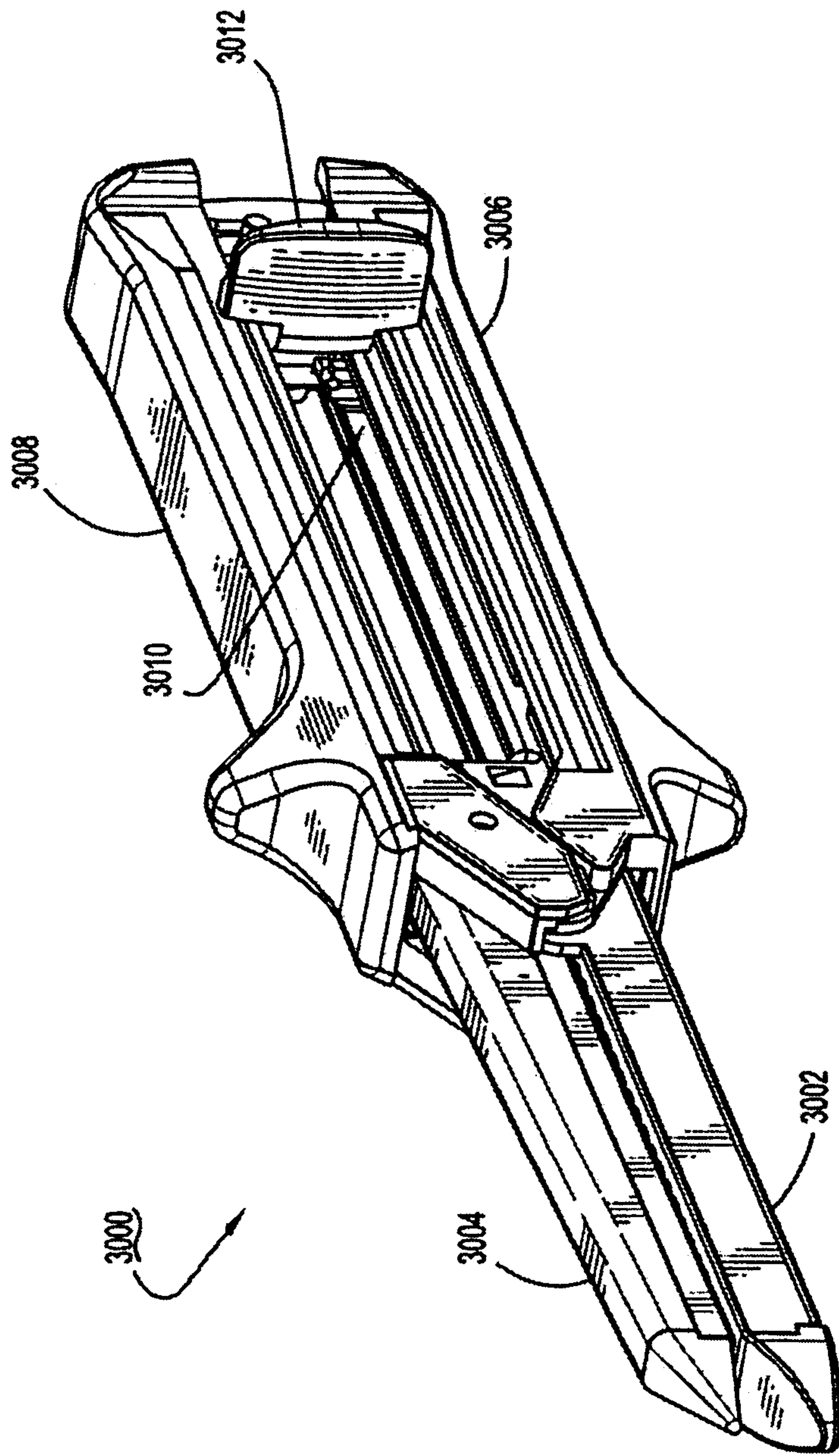



**FIG. 16**



**FIG. 17**



**FIG. 18**

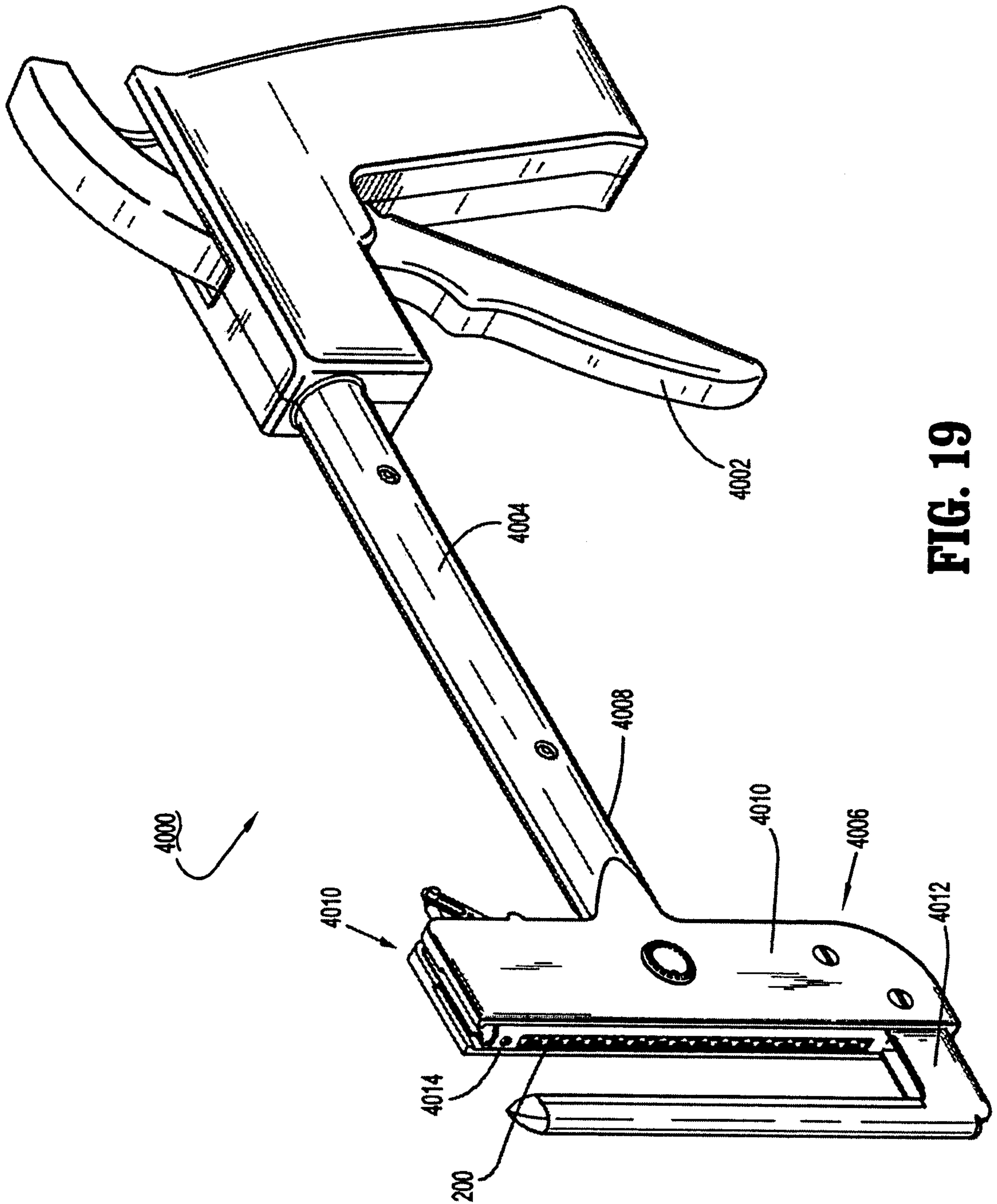

**FIG. 19**

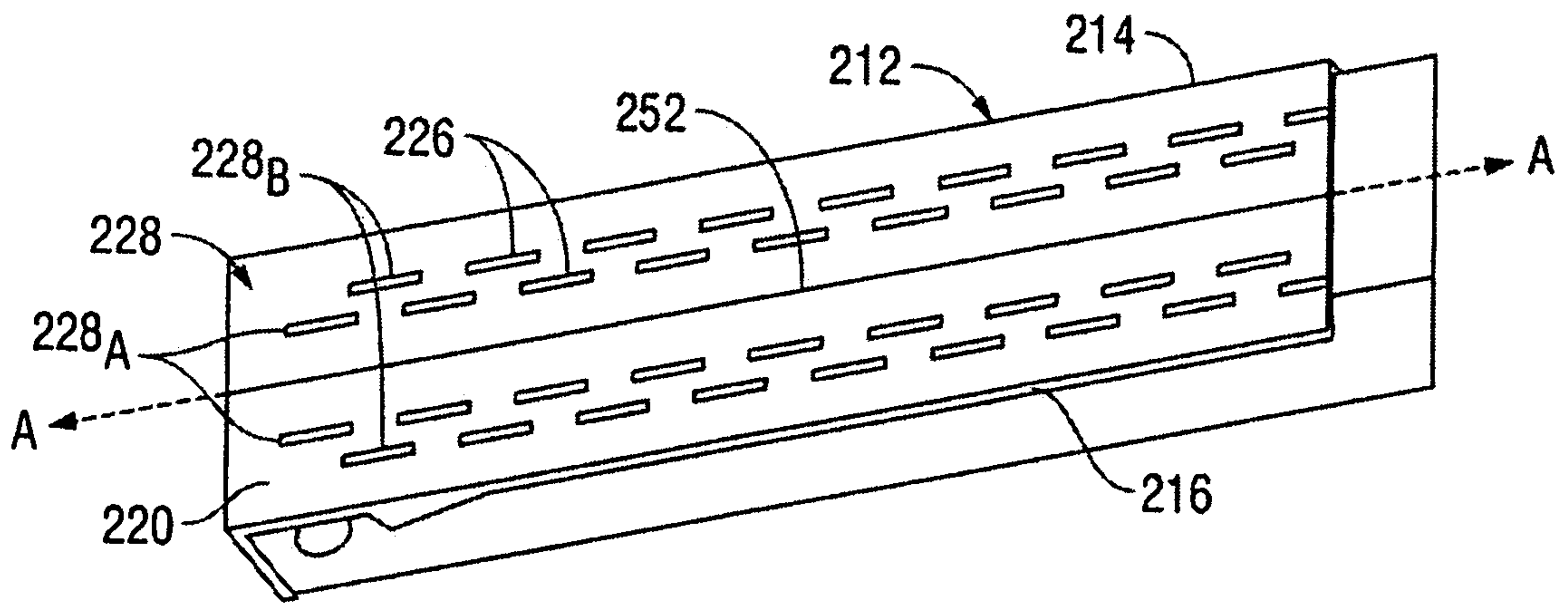

**FIG. 20**

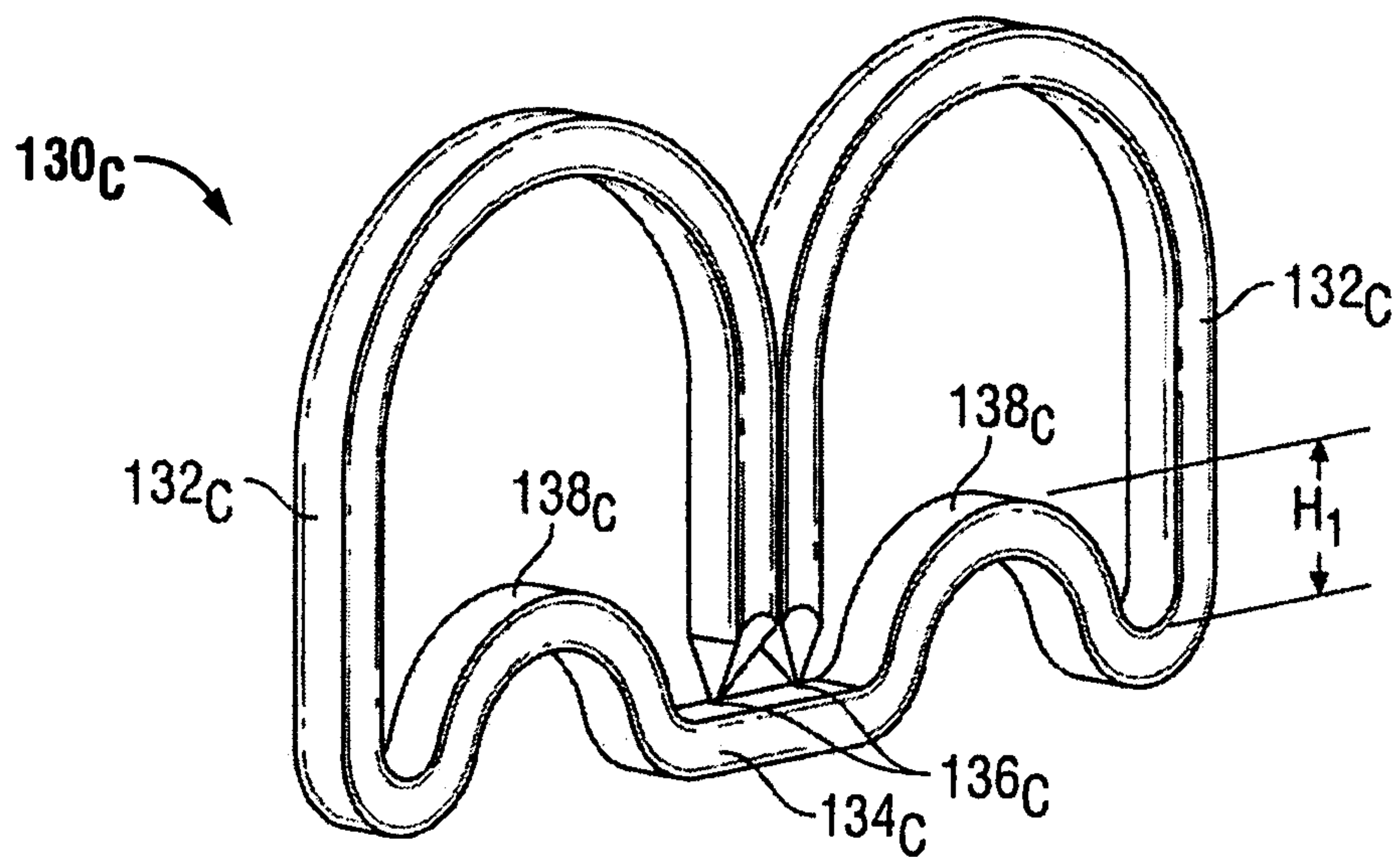

FIG. 21

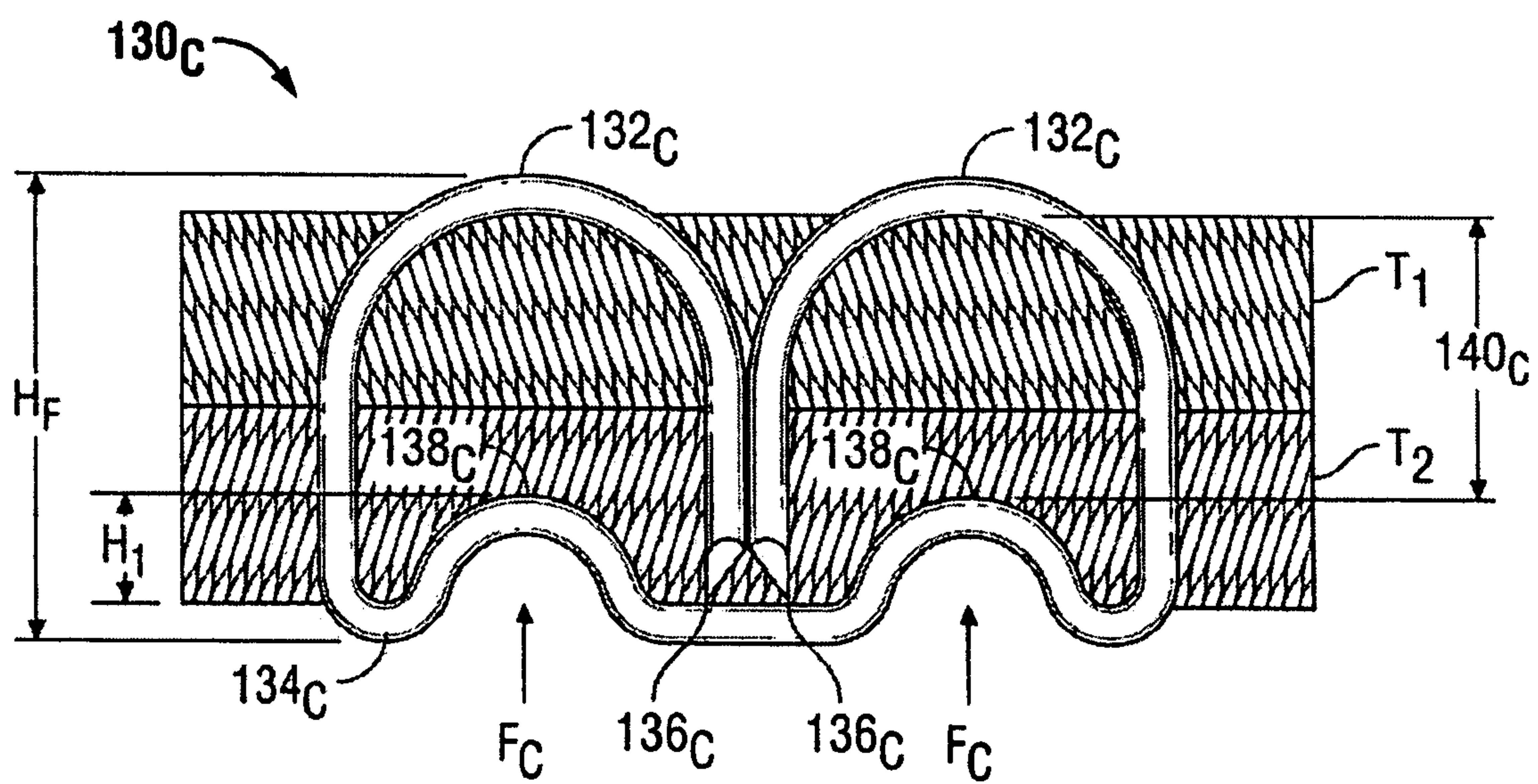

FIG. 22

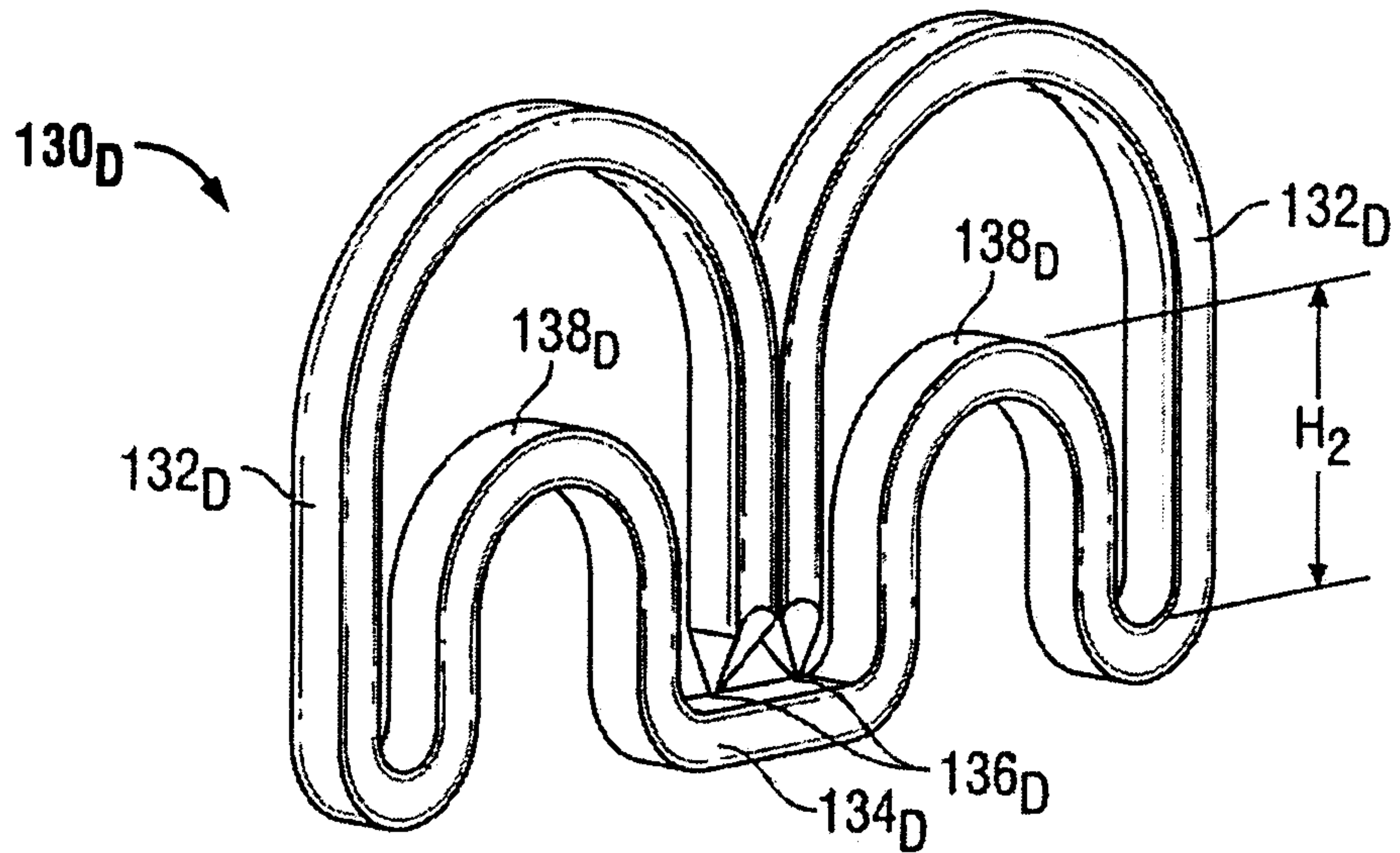

FIG. 23

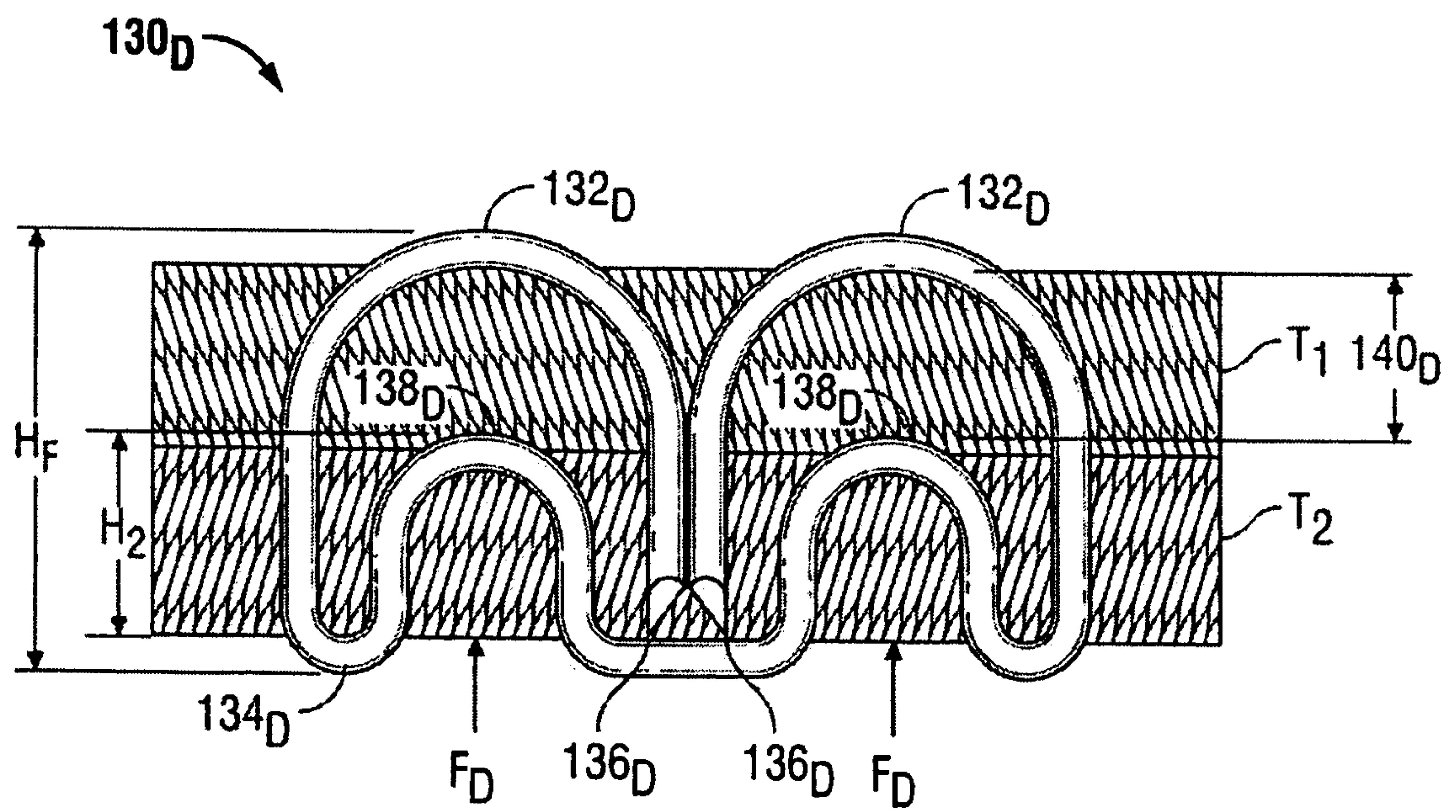

FIG. 24

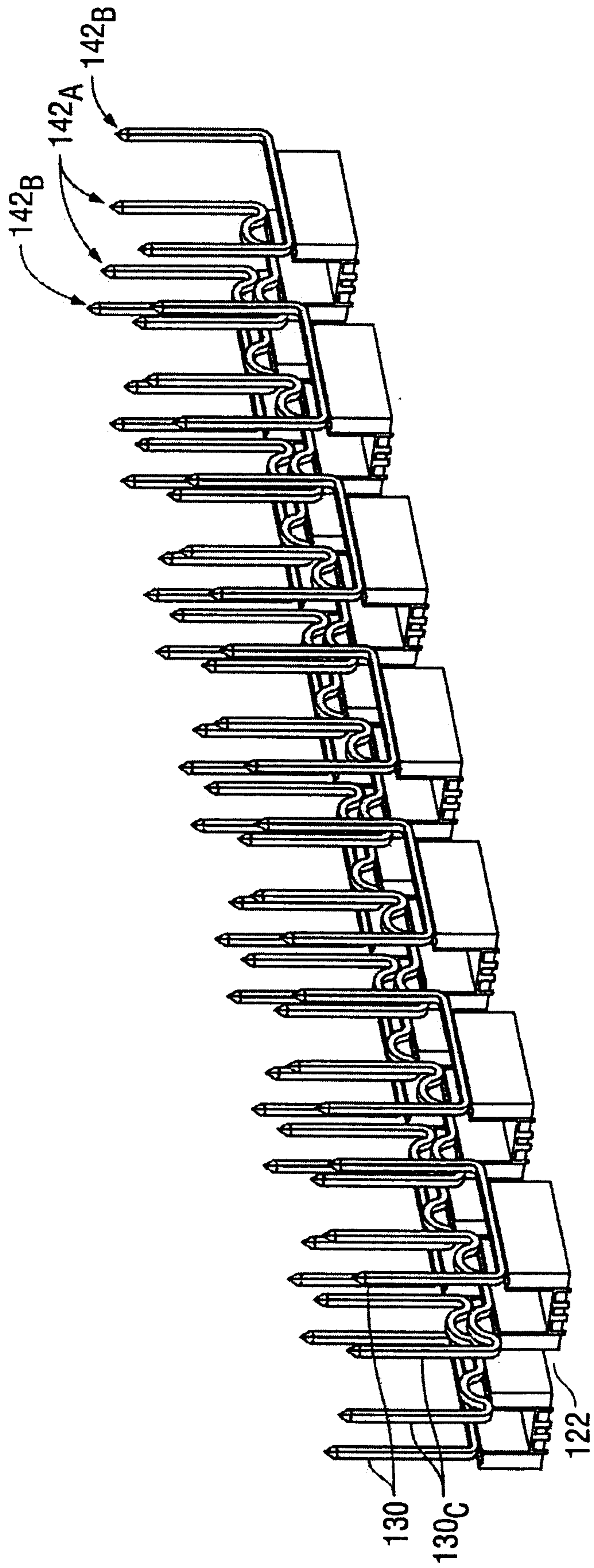
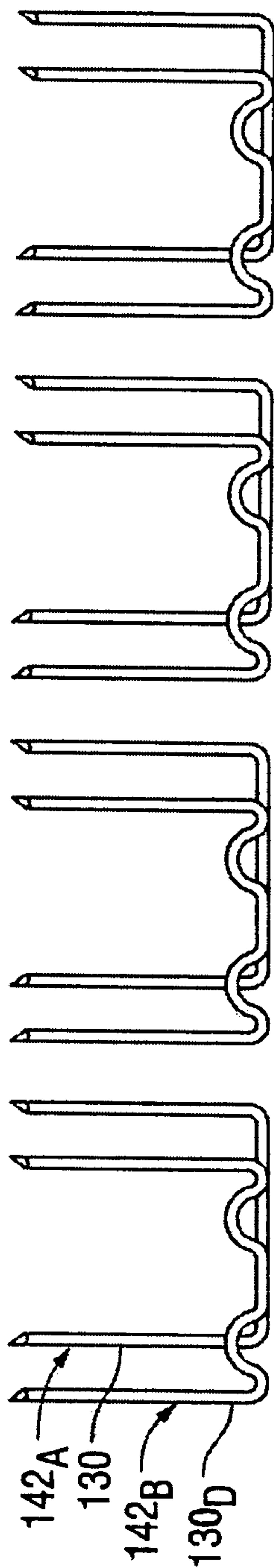

FIG. 25



**FIG. 26**

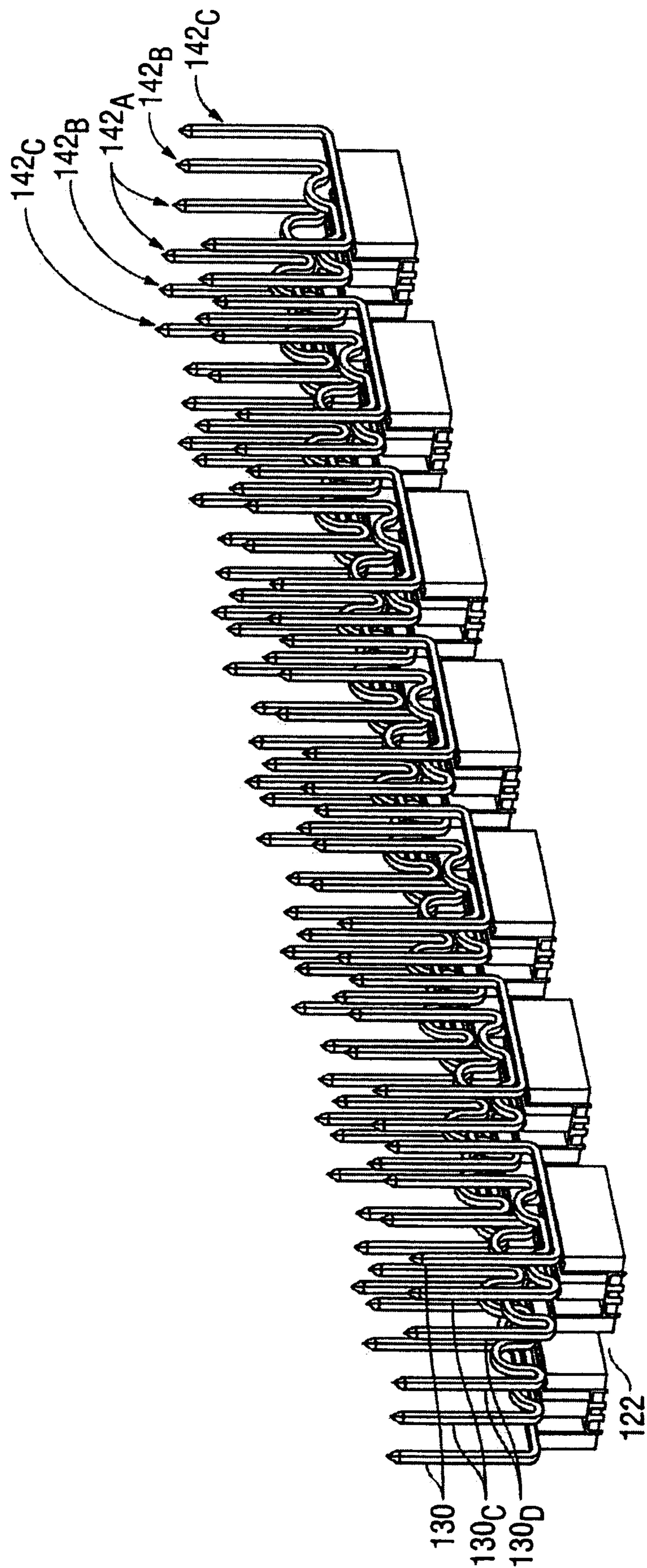
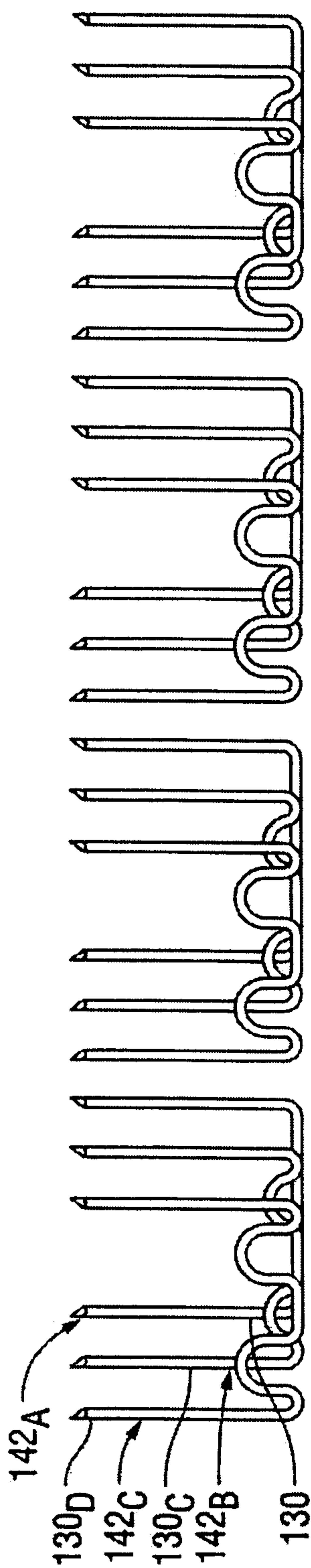

FIG. 27



**FIG. 28**

